

# Cilindri profilo in alluminio Serie 41K

Doppio effetto, ammortizzati, magnetici  
Ø 160 - 200 mm

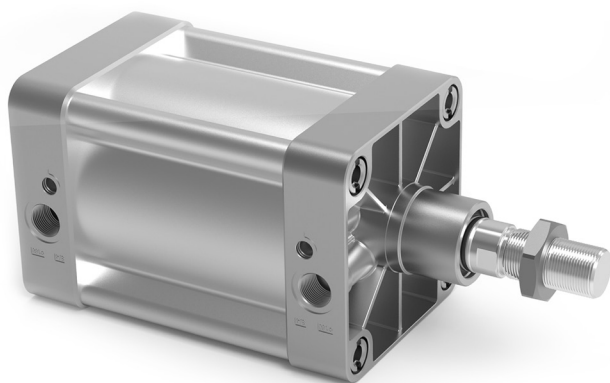

- » Conformi alla normativa ISO 15552 e alle precedenti norme DIN/ISO 6431 - VDMA 24562
- » Stelo in acciaio INOX rullato
- » Ammortizzatore pneumatico regolabile
- » Anello raschiastelo in ottone
- » ATEX

I cilindri Serie 41K sono conformi alla norma ISO 15552 e sono in grado di utilizzare tutta la gamma di accessori standard.

Il fissaggio del profilo alle testate è realizzato in modo estremamente sicuro per mezzo di tiranti passanti negli appositi alloggiamenti interni non visibili a cilindro assemblato. Questa serie di cilindri è normalmente fornita con ammortizzatori di fine corsa regolabili per mezzo di una vite posta sulla testata.

## CARATTERISTICHE GENERALI

<b>Tipo di costruzione</b>	a profilo (con tiranti)
<b>Funzionamento</b>	doppio effetto
<b>Design</b>	ISO 15552
<b>Materiali</b>	testate e pistone AL - stelo acciaio INOX AISI 420B rullato - dado stelo acciaio zincato - camicia profilo AL anodizzato tiranti e dadi tiranti acciaio zincato - guarnizioni stelo - pistone - ammortizzo NBR-PU - anello raschiastelo OT
<b>Fissaggio</b>	a flangia anteriore - a flangia posteriore - piedini - cerniera intermedia - cerniera anteriore e posteriore
<b>Corse min - max</b>	per tutti i diametri 10 ÷ 2500 mm
<b>Temperatura d'esercizio</b>	0°C ÷ 80°C (con aria secca - 20°C)
<b>Pressione d'esercizio</b>	1 ÷ 10 bar
<b>Velocità</b>	10 ÷ 500 mm/sec (senza carico) Versione ATEX Ø 160-200 10 ÷ 500 mm/sec
<b>Fluido</b>	aria filtrata, con o senza lubrificazione. Nel caso si utilizzasse aria lubrificata, si consiglia olio ISOVG32 e di non interrompere mai la lubrificazione

**TABELLA CORSE STANDARD PER CILINDRI**

CORSE STANDARD														
Ø	25	50	75	80	100	125	150	160	200	250	300	320	400	500
160		x			x		x		x				x	x
200		x			x				x					

x = doppio effetto

**ESEMPIO DI CODIFICA**

<b>41</b>	<b>K</b>	<b>2</b>	<b>P</b>	<b>160</b>	<b>A</b>	<b>0200</b>	
-----------	----------	----------	----------	------------	----------	-------------	--

<b>41</b>	SERIE	
<b>K</b>	VERSIONE K = standard magnetico	
<b>2</b>	FUNZIONAMENTO 2 = doppio effetto, ammortizzato - anteriore e posteriore 3 = doppio effetto, non ammortizzato 4 = doppio effetto, ammortizzato - posteriore 5 = doppio effetto, ammortizzato - anteriore 6 = doppio effetto, stelo passante, ammortizzato - anteriore e posteriore 8 = doppio effetto, stelo passante, non ammortizzato	SIMBOLI PNEUMATICI CD09 CD07 CD37 CD38 CD13 CD14
<b>P</b>	CARATTERISTICHE MATERIALI P = vedi tabella CARATTERISTICHE GENERALI pagina precedente R = tiranti INOX AISI 420B - dadi tiranti INOX AISI 303 C = stelo INOX AISI 303 rullato - dado stelo INOX AISI 304 U = stelo INOX AISI 303 rullato - dado stelo INOX AISI 304 - tiranti INOX AISI 420B - dadi tiranti INOX AISI 303 W = stelo INOX AISI 304 rullato - dado stelo INOX AISI 304 - tiranti INOX AISI 420B - dadi tiranti INOX AISI 303	
<b>160</b>	ALESAGGIO 160 = 160 mm - 200 = 200 mm	
<b>A</b>	TIPO COSTRUTTIVO A = standard F = cilindro con cerniera intermedia	
<b>0200</b>	CORSA (vedi tabella)  = standard V = guarnizione stelo in FKM W = tutte le guarnizioni in FKM +130°C C = verniciato PU. Colore: Grigio G = con raschiastelo OT (stelo INOX AISI 420B cromato, guarn. stelo NBR) ( ___ ) = stelo più lungo di ___ mm  Note: la versione C è disponibile su richiesta. Per maggiori informazioni contattare i nostri tecnici	
	CERTIFICAZIONI EX = ATEX	

CILINDRI SERIE 41K

**SIMBOLI PNEUMATICI**

I simboli pneumatici indicati nell'ESEMPIO DI CODIFICA sono riportati di seguito.

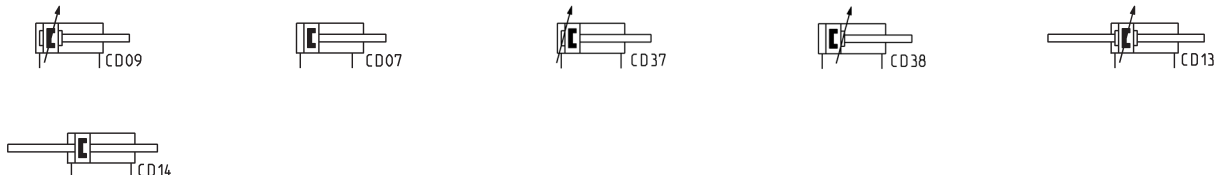

## ACCESSORI DISPONIBILI PER LA SERIE 41K



Spinotto Mod. S



Ancoraggio a cerniera combinata 90° Mod. ZS



Ancoraggio a cerniera maschio post. Mod. L

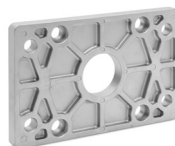

Flangia posteriore o anteriore Mod. D-E



Supporto per cerniera intermedia Mod. BF



Ancoraggio a cerniera intermedia Mod. F



Ancoraggio a piedini Mod. B



Forcella Mod. G



Cerniera femmina post. o ant. Mod. C-H



Snodo sferico Mod. GA



Combinazione dei Mod. C+L+S



Dado stelo Mod. U



Snodo autoallineante Mod. GK



Sensore Mod. CSN



Adattatore Mod. S53 per Sensore CSN

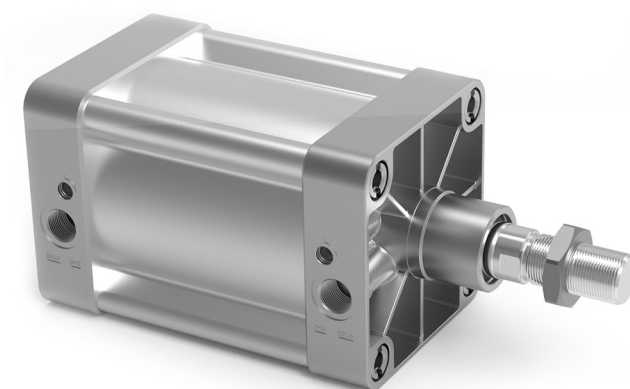

Tutti gli accessori sono forniti separatamente al cilindro, fatta eccezione del dado stelo Mod. U. Per i sensori e per le staffette porta sensore vedere la sezione dedicata.

**Cilindri Serie 41K**

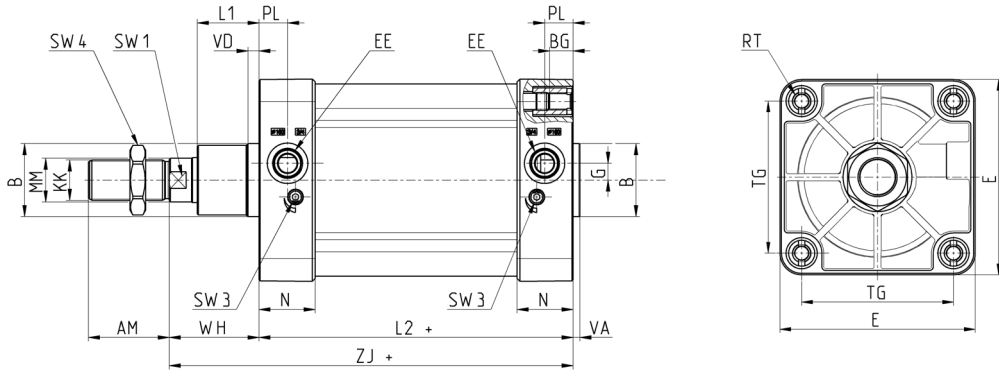
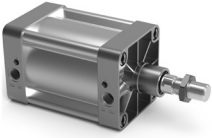

+ = sommare la corsa

$\varnothing$	$\varnothing$ MM	KK	$\varnothing$ B	PL	G	L1	AM	VA	EE	WH	L2+	ZJ+	VD	N	RT	BG	TG	E	SW1	SW3	SW4	Corsa Ammortizzo
160	40	M36X2	65	25,5	15	55	72	6	G3/4	80	180	260	10	50	M16	24	140	180	36	4	55	33
200	40	M36X2	75	25,5	15	65	72	8	G3/4	95	180	275	25	50	M16	24	175	220	36	4	55	48

**Cilindri Serie 41K - stelo passante**

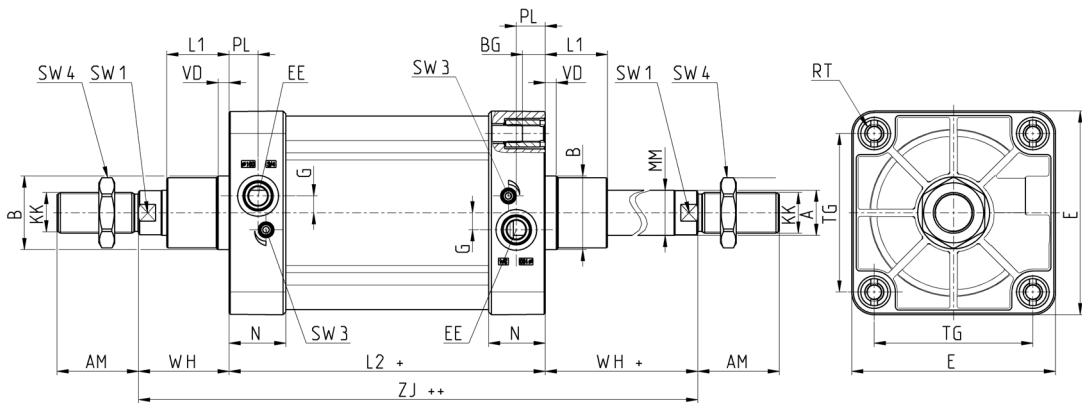

+ = sommare la corsa  
++ = sommare due volte la corsa

$\varnothing$	$\varnothing$ MM	KK	$\varnothing$ B	PL	G	L1	AM	VA	EE	WH	L2+	ZJ+	VD	N	RT	BG	TG	E	SW1	SW3	SW4	Corsa Ammortizzo
160	40	M36X2	65	25,5	15	55	72	6	G3/4	80	180	260	10	50	M16	24	140	180	36	4	55	33
200	40	M36X2	75	25,5	15	65	72	8	G3/4	95	180	275	25	50	M16	24	175	220	36	4	55	48

## Cilindri Serie 41K con cerniera Mod. F montata

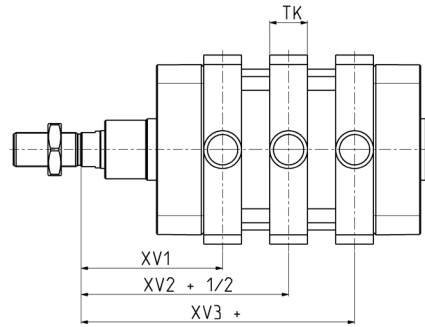
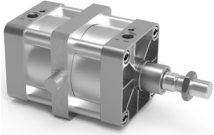

+ = sommare la corsa  
+ 1/2 = sommare metà corsa

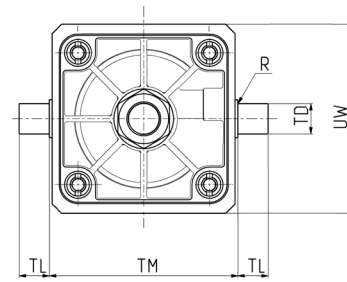

Mod.	∅	XV1	XV2+1/2	XV3+	TM	TK	TD	TL	UW	R
F-160	160	150	170	190	200	40	32	32	190	2
F-200	200	165	185	205	250	40	32	32	240	2

### Ancoraggio a piedini Mod. B



Materiale: Acciaio verniciato nero (cataforesi)  
La fornitura comprende:  
N° 2 piedini  
N° 4 viti

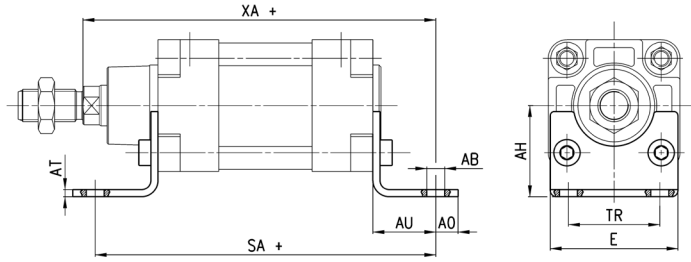

+ = sommare la corsa

INGOMBRI										
Mod.	∅	AT	SA+	XA+	TR	E	∅ <sub>AB</sub>	AH	A0	AU
B-41-160	160	10	300	320	115	175	18.5	115	25	60
B-41-200	200	12	320	345	135	238	24	135	35	70

### Ancoraggio a flangia posteriore o anteriore Mod. D-E

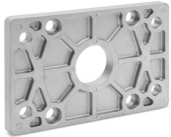

Materiale: Alluminio  
La fornitura comprende:  
N° 1 flangia  
N° 4 viti

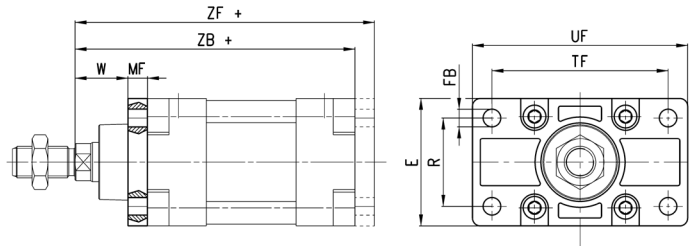

+ = sommare la corsa

INGOMBRI										
Mod.	∅	W	MF	ZB+	TF	R	UF	E	∅ <sub>FB</sub>	ZF+
D-E-41-160	160	60	20	260	230	115	260	180	18	280
D-E-41-200	200	70	25	275	270	135	300	220	22	300

### Ancoraggio a cerniera femmina posteriore o anteriore Mod. C-H



Materiale: Alluminio  
La fornitura comprende:  
N° 1 cerniera femmina  
N° 4 viti

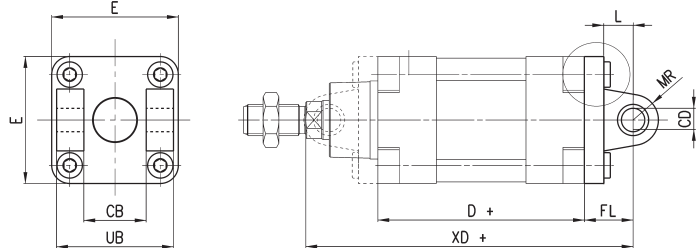

+ = sommare la corsa

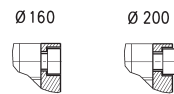

INGOMBRI										
Mod.	∅	∅ <sub>CD</sub>	L	FL	D+	XD+	MR	E	CB	UB
C-H-41-160	160	30	35	55	180	315	25	180	90	169
C-H-41-200	200	30	35	60	180	335	25	220	90	169

### Ancoraggio a cerniera maschio posteriore Mod. L



Materiale: Alluminio  
La fornitura comprende:  
N° 1 cerniera maschio  
N° 4 viti

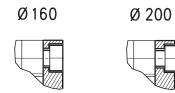
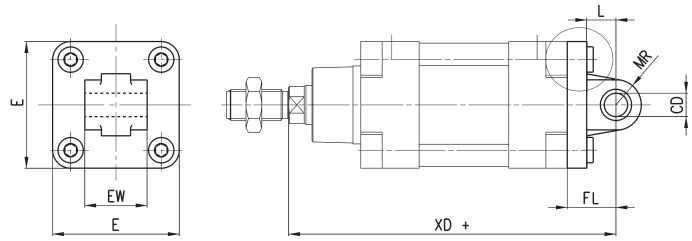

+ = sommare la corsa

INGOMBRI									
Mod.	Ø	øCD	L	FL	XD+	MR	E	EW <sup>-0.5-1.2</sup>	
L-41-160	160	30	35	55	315	25	180	90	
L-41-200	200	30	35	60	335	25	220	90	

### Ancoraggio a cerniera intermedia Mod. F



Materiale: acciaio zincato bianco.  
La fornitura comprende:  
N° 1 cerniera intermedia  
N° 4 elementi di fissaggio  
N° 4 grani

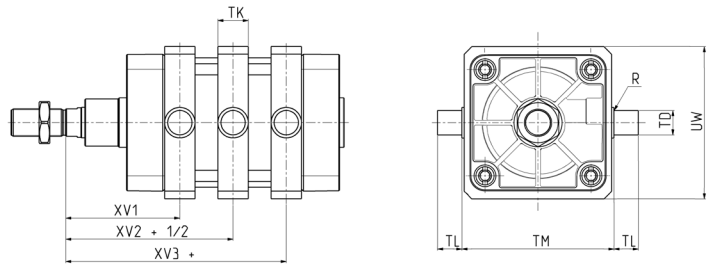

+ = sommare la corsa

INGOMBRI										
Mod.	Ø	XV1	XV+1/2	XV3+	TM	h	øTD	TL	UW	R
F-41-160	160	150	170	190	200	40	32	32	190	2
F-41-200	200	165	185	205	250	40	32	32	240	2

### Ancoraggio a cerniera combinata a 90° Mod. ZS



\* Ancoraggio non a norma ISO 15552

La fornitura comprende 1 ancoraggio a 45° in alluminio

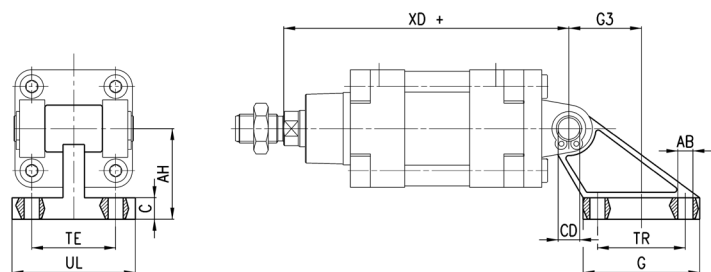

+ = sommare la corsa

INGOMBRI											
Mod.	Ø	TE	TR	øAB	AH	C	G	øCD	UL	XD+	G3
ZS-160*	160	140	140	18	140	20	180	30	180	315	105
ZS-160N	160	118	88	14	115	25	126	30	156	315	53
ZS-200*	200	175	175	18	140	25	220	30	220	335	125
ZS-200N	200	122	90	18	135	30	130	30	162	335	60

### Combinazione di accessori Mod. C+L+S

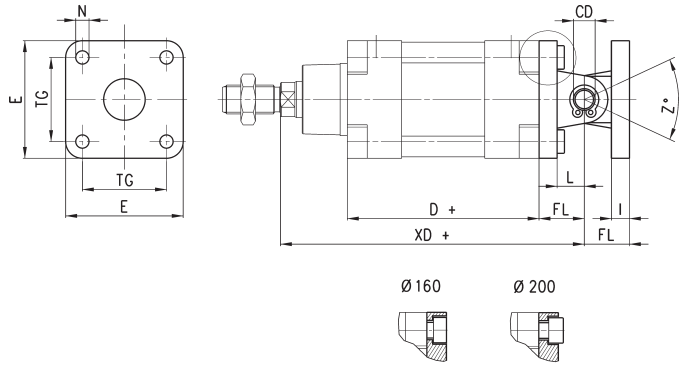

+ = sommare la corsa

INGOMBRI											
Mod.	Ø	Ø <sub>CD</sub>	L	FL	D+	XD+	TG	E	Ø <sub>N</sub>	I	Z° (max)
C+L+S	160	30	35	55	180	315	140	180	18	20	25
C+L+S	200	30	35	60	180	335	175	220	18	25	20

### Supporto per cerniera intermedia Mod. BF

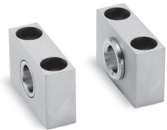

Materiale: Alluminio  
La fornitura comprende:  
N° 2 supporti

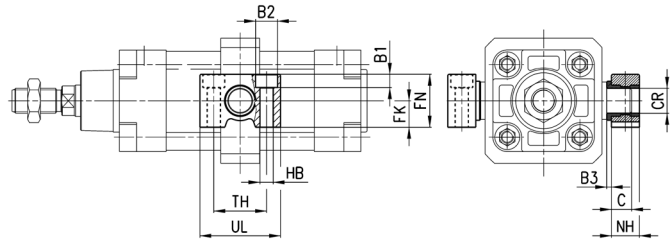

INGOMBRI												
Mod.	Ø	Ø <sub>CR</sub>	NH	C	B3	TH	UL	FK	FN	B1	Ø <sub>B2</sub>	Ø <sub>HB</sub>
BF-160-200	160-200	32	35	17,5	4	60	92	30	60	16	26	18

### Forcella Mod. G

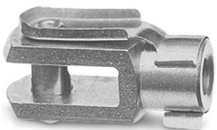

ISO 8140  
Materiale: Acciaio zincato

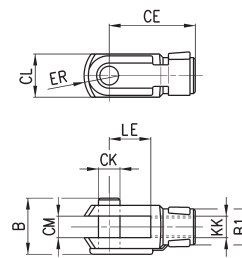

INGOMBRI										
Mod.	Ø	Ø <sub>CK</sub>	LE	CM	CL	ER	CE	KK	B	Ø <sub>B1</sub>
G-160-200	160-200	35	72	35	70	44	144	M36X2	92	60



## Snodo sferico Mod. GA



ISO 8139.  
Materiale: Acciaio zincato

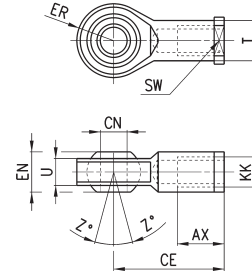

INGOMBRI											
Mod.	Ø	øCN	U	EN	ER	AX	CE	KK	ØT	Z	SW
GA-160-200	160-200	35	28	43	40	56	125	M36x2	46	6	50

## Spinotto Mod. S



La fornitura comprende:  
- 1 spinotto in acciaio INOX 303  
- 2 seeger in acciaio

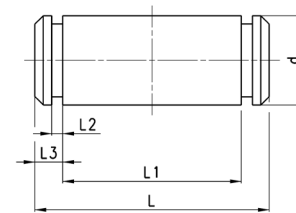

INGOMBRI						
Mod.	Ø	d	L	L1	L2	L3
S-160-200	160-200	30	180.5	172	1.6	4.25

## Dado stelo Mod. U



UNI EN ISO 4035  
Materiale: Acciaio zincato

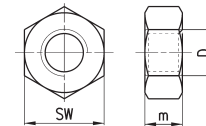

INGOMBRI				
Mod.	Ø	D	m	SW
U-160-200	160-200	M36x2	14	55

## Snodo autoallineante Mod. GK



Materiale: Acciaio zincato

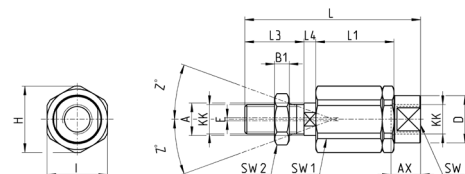

INGOMBRI																	
Mod.	Ø	KK	L	L1	L3	L4	øA	øD	H	I	SW	SW1	SW2	B1	AX	Z	E
GK-160-200	160-200	M36x2	190	77	72	15.5	39	57	75	70	54	32	55	14	68	4	2

### Sensore Mod. CSN



NOTA: ordinare separatamente il rispettivo adattatore S53.

Maggiori dettagli disponibili nel catalogo sensori.

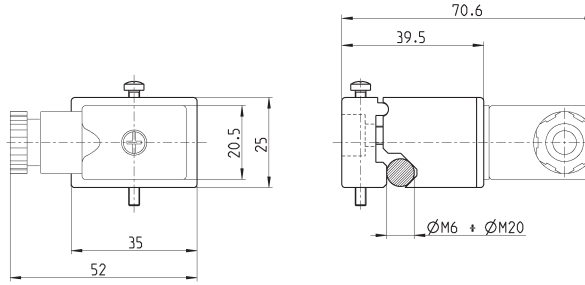

Mod.	Serie	Ø
CSN-2032-0	41K	160-200

### Adattatore Mod. S53 per sensore CSN

Materiale: Alluminio

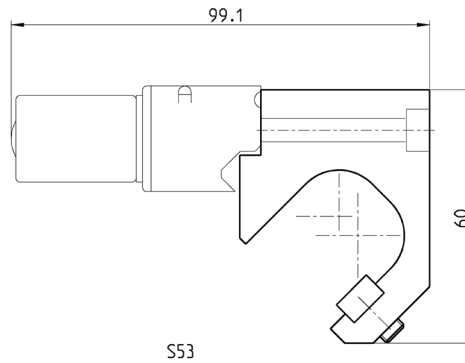

Mod.	Serie	Ø
S53	41K	160-200

## Chiave speciale per lo smontaggio di cilindri S.41K

Materiale: Acciaio

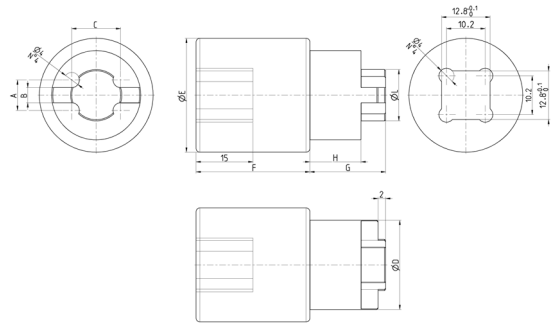

Mod.	Ø	A	B	C	ØD	ØE	F	G	H	ØL
160-200-40K/8C	160/200	8	4	12,9	23,5	30	30	20	13,5	13,5
250-40K/8C	250	9,5	5	16,6	31,5	30	27	24	16	17,5
320-40K/8C	320	9,5	5	20,3	35,5	32	27	24	16	21