

1000 系列卡套管接头

接头内带有单锥度或双锥度橄榄形铜套, 可连接退火紫铜管或塑料管
 连接管外径 4, 6, 8, 10, 12 mm
 连接螺纹 G1/8, G1/4, R1/8, R1/4, R3/8, R1/2



1000 系列卡套管接头可广泛用于各种工业领域, 连接简单可靠, 适用于退火紫铜管或塑料管的连接。接头内部铜套、螺母等配件符合 DIN 3870-3861 标准。

注: 连接塑料管时, 需选用 1320 型铜套。铜套需单独订购。

综合参数

连接管外径	4 ÷ 12 mm
连接螺纹	英制锥管螺纹 ISO 7 (BSPT) 英制圆柱管螺纹 ISO 228 (BSP)
工作温度	使用时, 同时取决于连接管的工作温度
连接管材料	退火紫铜管或塑料管
介质	压缩空气或低压流体
材料	黄铜镀镍基体
最大工作压力	40 bar (使用时, 同时取决于连接管的耐压)

气管连接示意图

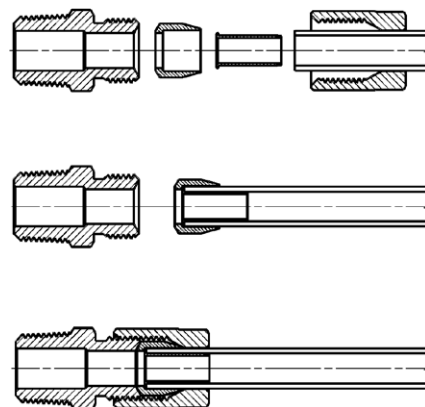

1050... 型卡套管接头

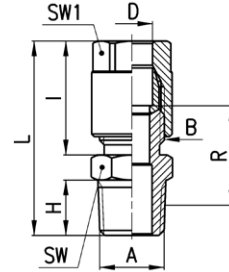

尺寸表										
型号	D	A	B	H	I	L	R	SW	SW1	质量 (g)
1050 4-1/8	4	R1/8	1/8	7.5	19	31	14	12	12	19
1050 6-1/8	6	R1/8	1/8	7.5	19	31	14	12	12	18
1050 6-1/4	6	R1/4	1/8	11	19	35	16.5	14	12	23
1050 8-1/8	8	R1/8	1/4	7.5	23	35	15.5	14	14	29
1050 8-1/4	8	R1/4	1/4	11	23	39	18	14	14	33
1050 8-3/8	8	R3/8	1/4	11.5	23	39.5	18	17	14	40
1050 10-1/4	10	R1/4	3/8	11	25.5	41.5	18	17	17	51
1050 10-3/8	10	R3/8	3/8	11.5	25.5	42	18	17	17	55
1050 10-1/2	10	R1/2	3/8	14	25.5	45	18	22	17	65
1050 12-1/4	12	R1/4	M18x1.5	11	24.5	40.5	12	19	19	56
1050 12-3/8	12	R3/8	M18x1.5	11.5	24.5	41	12	19	19	58
1050 12-1/2	12	R1/2	M18x1.5	14	24.5	44	12	22	19	68

* = 带有双锥度橄榄形铜套

1063... 型卡套管接头

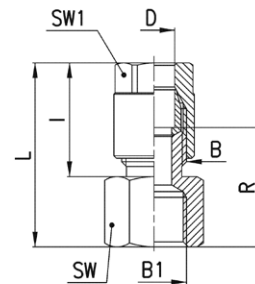

尺寸表										
型号	D	B1	B	I	L	R	SW	SW1	质量 (g)	
1063 4-1/8	4	G1/8	1/8	19	29	18.5	13	12	19	
1063 6-1/8	6	G1/8	1/8	19	29	18.5	13	12	18	
1063 6-1/4	6	G1/4	1/8	19	30.5	20	17	12	25	
1063 8-1/8	8	G1/8	1/4	23	33	20	14	14	31	
1063 8-1/4	8	G1/4	1/4	23	34.5	21.5	17	14	35	

1020... 型卡套管接头

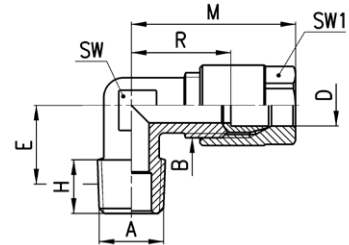

尺寸表											
型号	D	A	B	E	H	M	R	SW	SW1	质量 (g)	
1020 4-1/8	4	R1/8	1/8	11.5	7.5	29.5	19	9	12	21	
1020 6-1/8	6	R1/8	1/8	11.5	7.5	29.5	19	9	12	19	
1020 6-1/4	6	R1/4	1/8	13.5	11	29.5	19	12	12	27	
1020 8-1/8	8	R1/8	1/4	11.5	7.5	33	20	11	14	35	
1020 8-1/4	8	R1/4	1/4	13.5	11	33	20	12	14	36	
1020 8-3/8	8	R3/8	1/4	15.5	11.5	35	22	14	14	50	
1020 10-1/4	10	R1/4	3/8	15	11	38	22.5	13	17	59	
1020 10-3/8	10	R3/8	3/8	15.5	11.5	38	22.5	14	17	58	
1020 10-1/2	10	R1/2	3/8	16	14	38	22.5	16	17	78	
1020 12-1/4	12	R1/4	M18x1.5	15	11	37	16.5	15	19	66	*
1020 12-3/8	12	R3/8	M18x1.5	15	11.5	37	16.5	15	19	66	*
1020 12-1/2	12	R1/2	M18x1.5	16	14	37	16.5	16	19	75	*

* = 带有双锥度橄榄形铜套

1093... 型卡套管接头

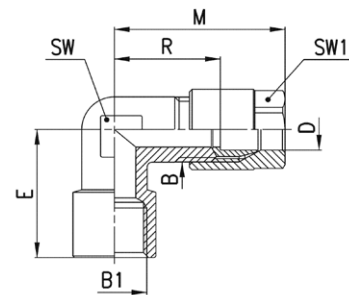

尺寸表									
型号	D	B1	B	E	M	R	SW	SW1	质量 (g)
1093 4-1/8	4	G1/8	1/8	19	29.5	18.5	12	12	31
1093 6-1/8	6	G1/8	1/8	19	29.5	19	12	12	25
1093 6-1/4	6	G1/4	1/8	23	30.5	20	13	12	39
1093 8-1/8	8	G1/8	1/4	19	33	20	11	14	39
1093 8-1/4	8	G1/4	1/4	23	35	22	13	14	44

1000... 型卡套管接头

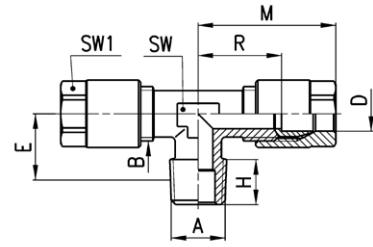

尺寸表										
型号	D	A	B	E	H	M	R	SW	SW1	质量 (g)
1000 4-1/8	4	R1/8	1/8	11.5	7.5	29.5	19	9	12	35
1000 6-1/8	6	R1/8	1/8	11.5	7.5	29.5	19	9	12	33
1000 8-1/4	8	R1/4	1/4	13.5	11	33	20	12	14	63
1000 10-1/4	10	R1/4	3/8	15	11	38	22.5	13	17	104

1010... 型卡套管接头

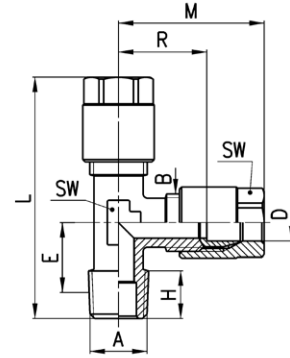

尺寸表											
型号	D	A	B	E	H	L	M	R	SW	SW1	质量 (g)
1010 4-1/8	4	R1/8	1/8	11.5	7.5	48	29.5	19	9	12	37
1010 6-1/8	6	R1/8	1/8	11.5	7.5	48	29.5	19	9	12	33
1010 8-1/4	8	R1/4	1/4	13.5	11	54.5	33	20	12	14	61
1010 10-1/4	10	R1/4	3/8	15	11	61.5	38	22.5	13	17	103

1230... 型卡套管接头

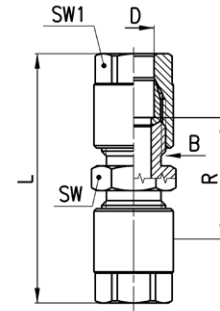

尺寸表							
型号	D	B	L	R	SW	SW1	质量 (g)
1230 4	4	1/8	42.5	21.5	12	12	29
1230 6	6	1/8	42.5	21.5	12	12	26
1230 8	8	1/4	51	25	14	14	48
1230 10	10	3/8	56	25	17	17	83
1230 12	12	M18x1.5	54	13	19	19	140

* = 带有双锥度橄榄形铜套

1250... 型卡套管接头

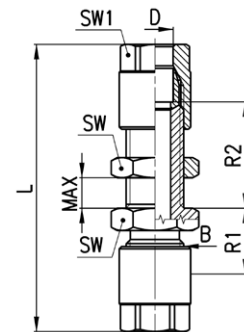

尺寸表									
型号	D	B	L	R1	R2	MAX	SW	SW1	质量 (g)
1250 4	4	1/8	57.5	12.5	23	12	14	12	40
1250 6	6	1/8	57.5	13	23.5	12	14	12	38
1250 8	8	1/4	65	15	24	13	17	14	67
1250 10	10	3/8	72.5	15	26.5	13	22	17	119

1220... 型卡套管接头

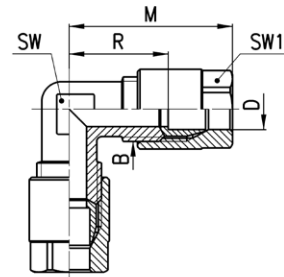

尺寸表							
型号	D	B	M	R	SW	SW1	质量 (g)
1220 4	4	1/8	29.5	19	9	12	31
1220 6	6	1/8	29.5	19	9	12	29
1220 8	8	1/4	33	20	11	14	53
1220 10	10	3/8	38	22.5	14	17	92
1220 12	12	M18x1.5	37	16.5	16	19	99 *

* = 带有双锥度橄榄形铜套

1210... 型卡套管接头

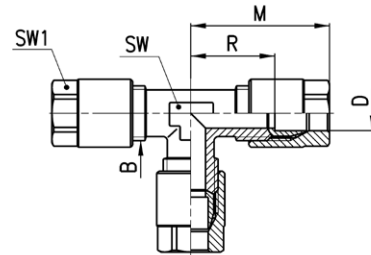

尺寸表							
型号	D	B	M	R	SW	SW1	质量 (g)
1210 4	4	1/8	29.5	19	9	12	45
1210 6	6	1/8	29.5	19	9	12	42
1210 8	8	1/4	33	20	12	14	79
1210 10	10	3/8	38	22.5	13	17	133
1210 12	12	M18x1.5	37	16.5	16	19	144 *

* = 带有双锥度橄榄形铜套

1170... 型卡套管接头

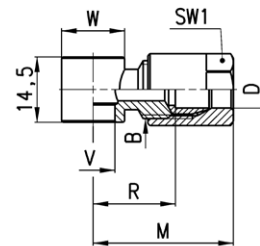

尺寸表										
型号	D	B	R	M	V	W	SW1	质量 (g)	可与下列产品配合使用	
1170 6-1/8	6	1/8	17.5	28	9.8	∅14	12	20	1631, 1635, SCU, SVU, SCO...	
1170 6-1/4	6	1/8	20	30.5	13.2	∅18	12	24	1631, 1635, SCU, SVU, SCO...	
1170 8-1/8	8	1/4	18	31	9.8	∅14	14	31	1635, SCU, SVU, SCO...	

1303... 型卡套管接头用螺母

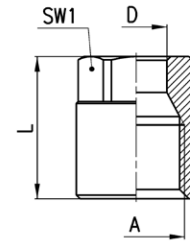

尺寸表					
型号	D	A	L	SW1	质量 (g)
1303 4-1/8	4	1/8	15.5	12	8
1303 6-1/8	6	1/8	15.5	12	8
1303 8-1/4	8	1/4	19	14	14
1303 10-3/8	10	3/8	21.5	17	24
1303 12-M18x1,5	12	M18x1.5	19.5	19	27

1310... 型卡套管接头用铜套

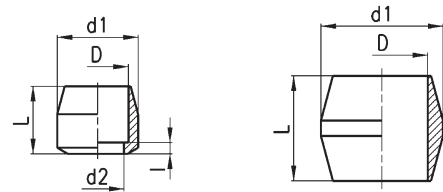

FIG. 1

FIG. 2

尺寸表						
型号	D	d1	d2	l	L	质量 (g)
1310 4	4	7.8	3	1	8	2
1310 6	6	7.8	4.5	1	7	1
1310 8	8	10.8	7	1.5	9	3
1310 10	10	13.8	9	1.5	11.5	5
1310 12-M18	12	16.3	12	-	11	6 *

Fig. 1 = 单锥度橄榄形铜套
Fig. 2 = 双锥度橄榄形铜套

* = 双锥度橄榄形铜套

1320... 型卡套管接头用铜套

用于连接管为塑料管时，需单独订购

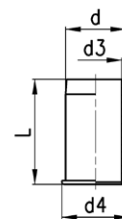

尺寸表					
型号	d	d3	d4	L	质量 (g)
1320 4	4	3	5	12	1
1320 6	6	5	7	13	1
1320 8	8	7	9	14	1
1320 10	10	9	11	16	2