

Vérins Série 42

Simple et double effet, magnétique Ø32-40-50-63 amorti

VÉRINS SÉRIE 42

- » Excellent alignement
- » Différentes options de fixation



Les vérins Série 42 ont été conçus sans tirants pour obtenir un aspect linéaire. Ils sont produits avec tige et tube inox et fonds aluminium. Cette série est équipée en série d'amortissements pneumatiques réglables. De plus, ils sont pourvus d'un amortissement élastique fixe réduisant l'impact du piston sur les fonds.

CARACTERISTIQUES GENERALES

Type de construction	compact serti
Fonctionnement	simple et double effet
Matériaux	fonds aluminium, tube inox AISI 304, tige inox roulée AISI 420B, autres voir codification.
Type de fixation	jeu de pieds/bride, contre-charnière, pivots
Courses	10 à 1000 mm
Température de fonctionnement	0 à 80°C (-20 °C avec air sec)
Pression de service	1 à 10 bar (double effet); 2 à 10 bar (simple effet ;
Vitesse	10 à 1000 mm/sec (sans charge)
Fluide	air filtré, sans lubrification ; En cas d'utilisation avec air lubrifié, il est conseillé d'utiliser de l'huile ISO VG32 et de ne jamais interrompre la lubrification.

TABLEAU DES COURSES STANDARDS DES VERINS SERIE 42

✕ = Double effet
■ = Simple effet

COURSES STANDARD														
Ø	25	50	75	80	100	125	150	160	200	250	300	320	400	500
32	✕ ■	✕ ■	✕ ■	✕	✕	✕	✕	✕	✕	✕	✕	✕	✕	✕
40	✕ ■	✕ ■	✕ ■	✕	✕	✕	✕	✕	✕	✕	✕	✕	✕	✕
50	✕ ■	✕ ■	✕ ■	✕	✕	✕	✕	✕	✕	✕	✕	✕	✕	✕
63	✕ ■	✕ ■	✕ ■	✕	✕	✕	✕	✕	✕	✕	✕	✕	✕	✕

CODIFICATION DES VERINS SERIE 42

42	M	2	N	050	A	0200
42	SERIE					
M	VERSION : M = standard, magnétique					
2	FONCTIONNEMENT : 1 = simple effet (amortissement ressort avant) 2 = double effet (amortissement avant et arrière) 3 = double effet (non-amorti) 4 = double effet (amortissement arrière) 5 = double effet (amortissement avant) 6 = double effet (tige traversante, amortissement avant et arrière) 7 = simple effet (tige traversante, amortissement)			SYMBOLES PNEUMATIQUES CS12 CD09 CD08 CD10 CD11 CD13 CS13		
N	MATERIAUX N = tige inox roulée AISI 420B, tube inox AISI 304, joints NBR					
050	ALESAGE : 032 = 32 mm 040 = 40 mm 050 = 50 mm 063 = 63 mm					
A	ACCESSOIRES : A = standard (écrou de nez et écrou de tige)					
0200	COURSE : voir tableau					

SYMBOLES PNEUMATIQUES

Les symboles pneumatiques indiqués dans la CODIFICATION sont représentés ci-dessous.

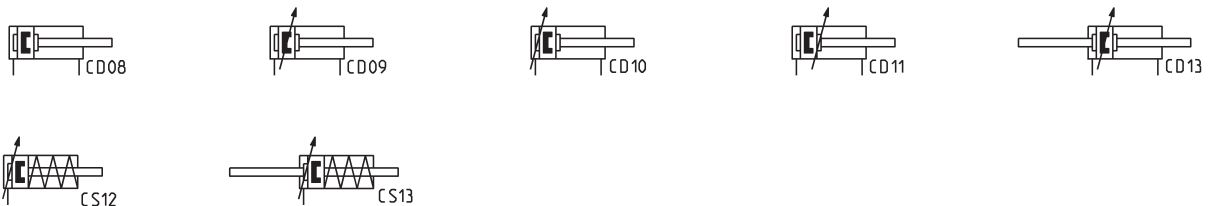

ACCESSOIRES POUR LA SERIE 42

VÉRINS SÉRIE 42



Ecroû de nez Mod. V-42



Bride de compensation Mod. GKF



Chape de compensation de tige Mod. GK



Chape à rotule de tige Mod. GY



Chape de tige Mod. G



Jeu de pieds/brides Mod. P

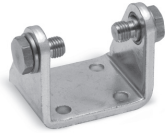

Contre-charnière Mod. I



Chape sphérique de tige Mod. GA



Pivots Mod. T



Ecroû de tige Mod. U



Fournis avec écrou de fond Mod. V et écrou de tige Mod. U. Les accessoires sont livrés non-montés sur les vérins.

Vérins Série 42

note : les valeurs des colonnes L, L1 et L2 doivent être augmentées de 25mm en simple effet



+ signifie ajouter la course
* = Course d'amortissement avant/arrière

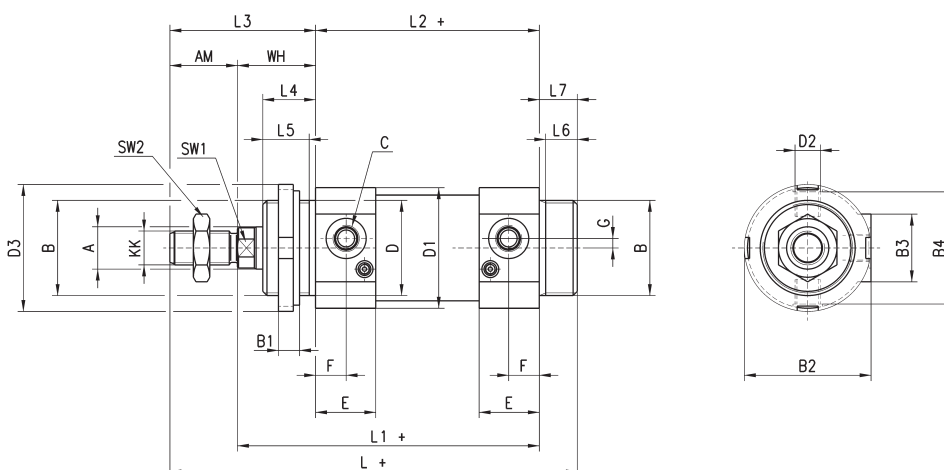

DIMENSIONS																												
Ø	A	KK	B	B1	B2	B3	B4	C	D ^{#11}	D1	D2	D3	E	F	G	SW1	SW2	AM	WH	L+	L1+	L2+	L3	L4	L5	L6	L7	*
32	12	M10x1.25	M30x1.5	8	41.5	28	36	G1/8	30	38	M8x1	42	23.5	10.5	5	10	17	22	26	156	120	94	48	18	15	11	14	17/12
40	16	M12x1.25	M38x1.5	10	50	30	43	G1/4	38	46	M10x1	50	29	15	5	13	19	24	30	175	135	105	54	22	19	13	16	20/17
50	20	M16x1.5	M45x1.5	10	58.5	32	54	G1/4	40	57	M12x1.5	60	28.5	14.5	4.5	17	24	32	37	193	143	106	69	25	22	15	18	15/14
63	20	M16x1.5	M45x1.5	10	70.5	46.5	66	G3/8	45	70	M14x1.5	60	35	15.5	7	17	24	32	37	208	158	121	69	25	22	15	18	17/16

Vérins Série 42

Tige traversante

note : les valeurs des colonnes L, L1 et L2 doivent être augmentées de 25mm en simple effet



+ signifie ajouter la course
++ ajouter 2 fois la course
* = Course d'amortis. avant/arrière

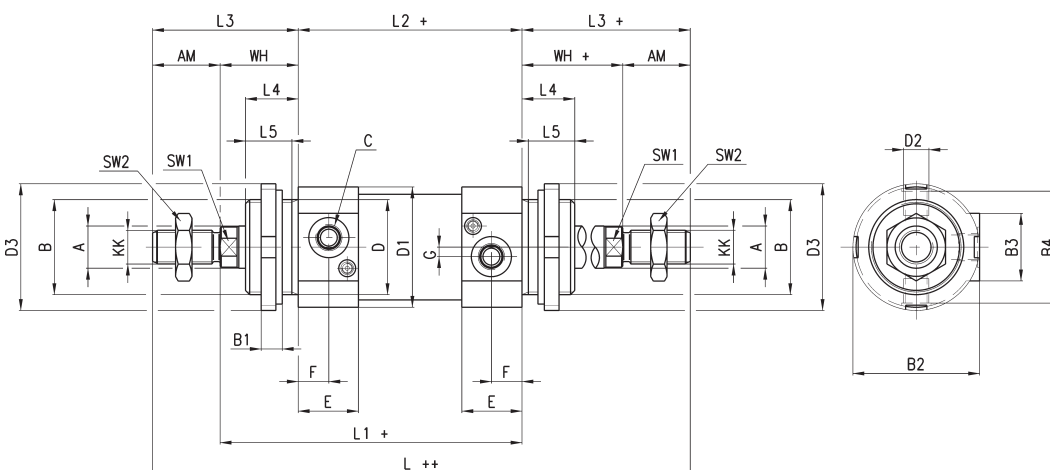

DIMENSIONS																											
Ø	A	KK	B	B1	B2	B3	B4	C	D	D1	D2	D3	E	F	G	SW1	AM	SW2	WH+	L++	L1+	L2+	L3+	L4	L5	*	
32	12	M10x1.25	M30x1.5	8	41.5	28	36	G1/8	30	38	M8x1	42	23.5	10.5	5	10	22	17	26	190	120	94	48	18	15	17/12	
40	16	M12x1.25	M38x1.5	10	50	30	43	G1/4	38	46	M10x1	50	29	15	5	13	24	19	30	213	135	105	54	22	19	20/17	
50	20	M16x1.5	M45x1.5	10	58.5	32	54	G1/4	45	57	M12x1.5	60	28.5	14.5	4.5	17	32	24	37	244	143	106	69	25	22	15/14	
63	20	M16x1.5	M45x1.5	10	70.5	46.5	66	G3/8	45	70	M14x1.5	60	35	15.5	7	17	32	24	37	259	158	121	69	25	22	17/16	

Jeu de pieds/brides Mod. P



Matériau : acier zingué

Complet avec :
2 pieds
1 écrou

+ signifie ajouter la course

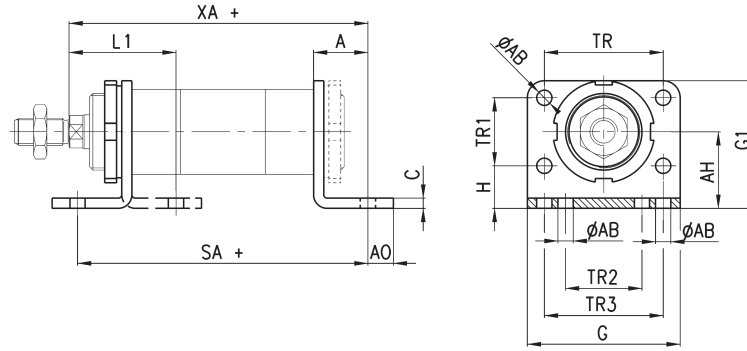

DIMENSIONS																
Mod.	∅	L1	SA +	XA +	A	AB	AO	AH	C	G	G1	TR	TR1	TR2	TR3	H
P-42-32	32	46	142	144	24	7	11	32	4	66	53	52	28	32	52	18
P-42-40	40	53	161	163	28	9	15	36	5	80	61	60	30	36	60	21
P-42-50	50	63	170	175	32	9	15	45	6	90	75	70	40	45	70	25
P-42-63	63	63	185	190	32	9	10	50	6	96	85	76	50	50	76	25

Contre-charnière Mod. I



Matériau : acier zingué

Complet avec :
1 charnière femelle
2 axes

+ signifie ajouter la course

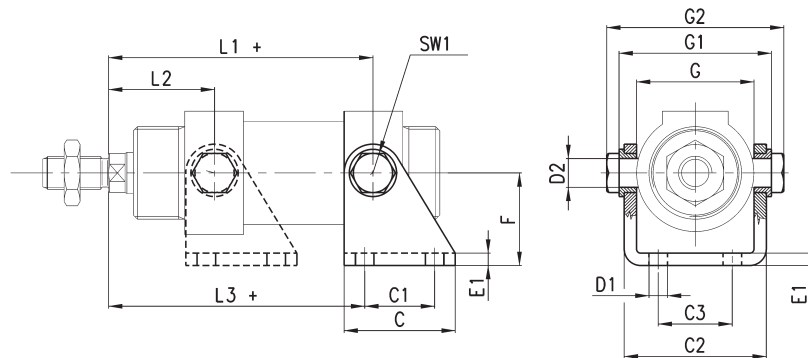

DIMENSIONS																
Mod.	∅	L1 +	L2	L3 +	C	C1	C2	C3	D1	D2	E1	F	SW1	G	G1	G2
I-42-32	32	109,5	36,5	105,5	40	24	46,1	20	7	10	4	35	13	38,1	50,1	58,1
I-42-40	40	120	45	117	50	30	56,1	28	9	12	5	40	17	46,1	60,1	70,1
I-42-50	50	128,5	51,5	124,5	54	34	69,1	36	9	14	6	45	19	57,1	74,1	86,1
I-42-63	63	143	52	142	65	35	82,1	42	9	16	6	50	19	70,1	88,1	100,1

Pivots Mod. T



Matériau : inox

Complet avec :
2 pivots

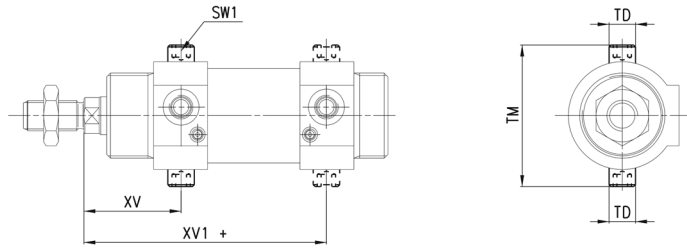

+ signifie ajouter la course

DIMENSIONS						
Mod.	∅	XV	XV1+	TD	TM	SW1
T-42-32	32	36,5	109,5	10	51	5
T-42-40	40	45	120	12	61	6
T-42-50	50	51,5	128,5	14	75	6
T-42-63	63	52	143	16	90	8

Ecrou de nez/fond Mod. V-42



Matériau : acier zingué

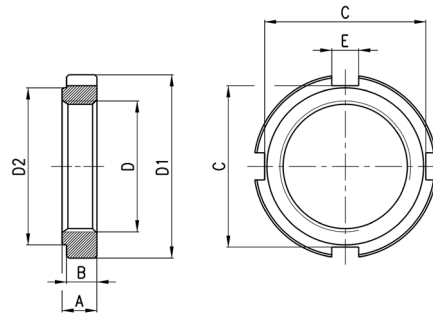

+ signifie ajouter la course

DIMENSIONS								
Mod.	∅	D	D1	D2	A	B	C	E
V-42-32	32	M30x1,5	42	36	8	7	37	6,2
V-42-40	40	M38x1,5	50	48	10	9	44	7,2
V-42-50-63	50-63	M45x1,5	60	56	10	9	53	7,2

Chape de tige Mod. G



ISO 8140

Matériau : acier zingué

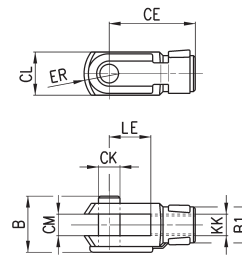

DIMENSIONS										
Mod.	∅	∅CK	LE	CM	CL	ER	CE	KK	B	B1
G-25-32	32	10	20	10	20	12	40	M10x1,25	26	18
G-40	40	12	24	12	24	14	48	M12x1,25	32	20
G-50-63	50-63	16	32	16	32	19	64	M16x1,5	40	26

Ecrou de tige Mod. U



UNI 5589
Matériau : acier zingué

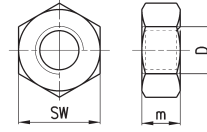

DIMENSIONS				
Mod.	∅	D	m	SW
U-25-32	32	M10X1,25	6	17
U-40	40	M12X1,25	7	19
U-50-63	50-63	M16X1,5	8	24

Chape sphérique de tige Mod. GA



ISO 8139
Matériau : acier zingué

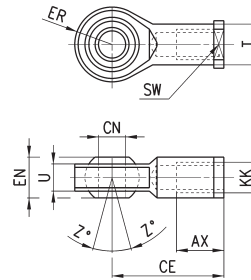

DIMENSIONS											
Mod.	∅	∅CN	U	EN	ER	AX	CE	KK	T	Z	SW
GA-32	32	10	10,5	14	14	20	43	M10X1,25	15	6,5	17
GA-40	40	12	12	16	16	22	50	M12X1,25	17,5	6,5	19
GA-50-63	50-63	16	15	21	21	28	64	M16X1,5	22	7,5	22

Chape à rotule de tige Mod. GY



Matériau : zama et acier zingué

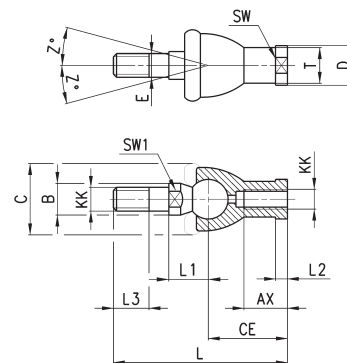

DIMENSIONS																
Mod.	∅	KK	L	CE	L2	AX	SW	SW1	L1	L3	∅T	∅D	E	∅B	∅C	Z
GY-32	32	M10x1,25	74	35	6,5	18	17	11	19,5	15	15	19	10	14	28	15
GY-40	40	M12x1,25	84	40	6,5	20	19	17	22	17	17,5	22	12	19	32	15
GY-50-63	50-63	M16x1,5	112	50	8	27	22	19	27,5	23	22	27	16	22	40	11

Chape de compensation de tige Mod. GK

Matériau: acier zingué

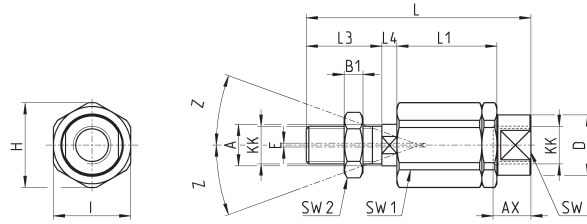

DIMENSIONS																	
Mod.	∅	KK	L	L1	L3	L4	∅ A	∅ D	H	I	SW	SW1	SW2	B1	AX	Z	E
GK-25-32	32	M10x1,25	71,5	35	20	7,5	14	22	32	30	19	12	17	5	22	4	2
GK-40	40	M12x1,25	75,5	35	24	7,5	14	22	32	30	19	12	19	6	22	4	2
GK-50-63	50-63	M16x1,5	104	53	32	10	22	32	45	41	27	20	24	8	30	3	2

Bride de compensation Mod. GKF

Matériau: acier zingué

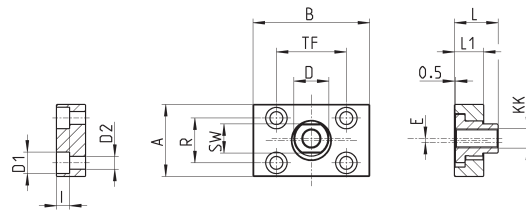

DIMENSIONS														
Mod.	∅	KK	A	B	R	TF	L	L1	I	∅D	∅D1	∅D2	SW	E
GKF-25-32	32	M10x1,25	37	60	23	36	22,5	15	6,8	18	11	6,6	15	2
GKF-40	40	M12x1,25	56	60	38	42	22,5	15	9	20	15	9	15	2,5
GKF-50-63	50-63	M16x1,5	80	80	58	58	26,5	15	10,5	25	18	11	22	2,5