

6000 系列快插管接头

连接管外径 3, 4, 5, 6, 8, 10, 12, 14, 16 mm

连接螺纹 M3, M5, M6, M7, G1/8, G1/4, G3/8, G1/2, G3/4
R1/8, R1/4, R3/8, R1/2

6000 系列快插管接头



6000 系列快插管接头共有 48 种不同的类型，可以在不借助工具的情况下方便地插入或拔出气管，且可重复使用。管接头内的 O 型圈损坏或随着时间的变化而损耗时，可以方便地更换。

自封闭型快插管接头内部自带封闭结构，当拔出连接管时，气流被切断，当连接管重新连接后，恢复供气。

管接头由黄铜制成，表面镀镍。

综合参数

连接管外径	标准型: $\varnothing 4 - 5 - 6 - 8 - 10 - 12 - 14 - 16$ mm 微型: $\varnothing 3 - 4 - 6 - 8 - 10$ mm
连接螺纹	标准型: 英制锥管螺纹 ISO 7 (BSPT) 英制圆柱管螺纹 ISO 228 (BSP) 微型: M3 - M5 - M7 - G1/8 - G1/4
工作温度	标准型: $-20^{\circ}\text{C} \div 80^{\circ}\text{C}$ (使用时, 同时取决于连接管的工作温度) 微型: $-10 \div 80^{\circ}\text{C}$ (使用时, 同时取决于连接管的工作温度)
连接管材料	尼龙 (PA 6 - PA 11 - PA 12), 聚氨酯 (PU), 聚乙烯 (PE)
介质	压缩空气 (如果用于其它介质, 请联系我们的销售工程师)
材料	标准型: 镀镍黄铜基体及开槽夹头, 丁腈橡胶 O 型圈, 聚四氟乙烯、丁腈橡胶、尼龙连接螺纹密封件 自封闭型: 镀镍黄铜基体及开槽夹头, 黄铜阀芯, 不锈钢弹簧, 丁腈橡胶 O 型圈, 聚四氟乙烯连接螺纹密封件
工作压力	标准型: $-0.9 \div 16$ bar (使用时, 同时取决于连接管的耐压) 自封闭型: $0 \div 16$ bar (使用时, 同时取决于连接管的耐压)

气管连接示意图

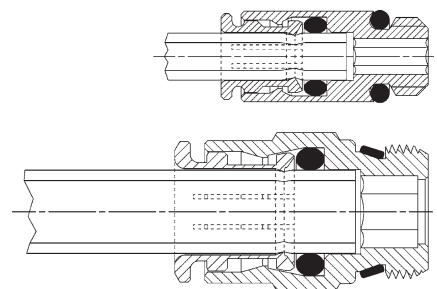

S6510... 型快插管接头



尺寸表										
型号	A	D	C	F	G	H	L	SW	SW1	质量 (g)
S6510 4-1/8	4	G1/8	3.8	8.8	13.2	5.5	18	12	2.5	9
S6510 4-1/4	4	G1/4	5.5	8.8	15.2	7	19.5	14	2.5	15
S6510 5-1/8	5	G1/8	3.8	9.8	13.2	5.5	19	12	3	8
S6510 5-1/4	5	G1/4	5.5	9.8	15.2	7	20	14	3	14
S6510 6-1/8	6	G1/8	6	11.7	13.2	5.5	22	12	4	10
S6510 6-1/4	6	G1/4	5.5	11.7	15.2	7	21	14	4	14
S6510 6-3/8	6	G3/8	6.5	11.7	20.5	8	22.5	19	4	27
S6510 8-1/8	8	G1/8	7.5	13.7	15.2	5.5	25	14	5	13
S6510 8-1/4	8	G1/4	6.5	13.7	15.2	7	24	14	6	14
S6510 8-3/8	8	G3/8	6	13.7	20.5	8	23.5	19	6	25
S6510 8-1/2	8	G1/2	7.5	13.7	24.5	9	25	22	6	43
S6510 10-1/4	10	G1/4	8.3	15.4	18.5	7	28.5	17	7	23
S6510 10-3/8	10	G3/8	5.3	15.4	20.5	8	25.5	19	8	27
S6510 10-1/2	10	G1/2	4.8	16	24.5	9	25	22	8	39
S6510 12-1/4	12	G1/4	10.3	18.3	20.5	7	29.5	19	7	26
S6510 12-3/8	12	G3/8	9.3	18.3	20.5	8	28.5	19	9	30
S6510 12-1/2	12	G1/2	5.8	18.3	24.5	9	25	22	10	36
S6510 14-3/8	14	G3/8	10.3	20.5	24.5	8	30.5	22	9	42
S6510 14-1/2	14	G1/2	6.3	20.5	24.5	9	26.5	22	12	34
S6510 16-1/2	16	G1/2	9	23.5	26.5	9	32	24	-	42
S6510 16-3/4	16	G3/4	3.5	23.5	27.3	9	26.5	24	-	46

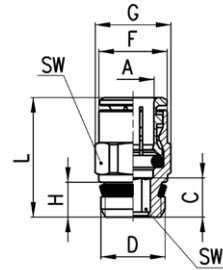

S6510...-LF 型快插管接头



自封闭型快插管接头

当拔出连接管时，气流被切断，当连接管重新连接后，恢复供气。

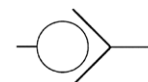
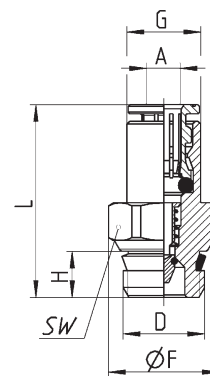

尺寸表									
型号	A	D	F	G	H	L	SW	质量 (g)	
S6510 4-1/8-LF	4	G1/8	13.2	8.8	5.5	23	12	11	
S6510 6-1/8-LF	6	G1/8	13.2	11.7	6	30.5	12	15	

6512... 型快插管接头

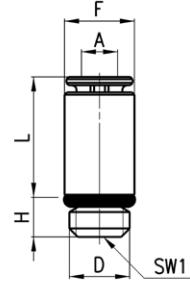

尺寸表								
型号	A	D	F	H	L	SW1	质量 (g)	
6512 3-M3	3	M3	5.8	2.5	10.2	1.5	1	*
6512 3-M5	3	M5	5.8	3.5	10	2	1	●
6512 4-M7-M	4	M7	9.4	5	17.5	2.5	5	●
6512 4-1/8-M	4	G1/8	11.2	5	13	2.5	9	●, Y
6512 6-M7-M	6	M7	10.4	5	17	4	7	●
6512 6-1/8-M	6	G1/8	11.2	5	14	4	7	●, Y
6512 8-1/8-M	8	G1/8	12.4	5	18.5	5	10	●, Y
6512 10-1/4-M	10	G1/4	14.8	6	21	7	16	●

- * = 与所附 2661 型垫圈配套安装
- = 与所附 O 型圈配套安装
- , Y = 与所附 O 型圈配套安装, 可用于 Y 系列阀岛

6512... 型快插管接头

与所附 O 型圈配套安装



尺寸表										
型号	A	D	C	F	G	H	L	SW	SW1	质量 (g)
6512 4-M5	4	M5	14.0	7.8	8.8	4	20	8	2	4
6512 4-M6	4	M6	14.0	8.8	9.9	4.5	20.5	9	2.5	6
6512 4-1/8	4	G1/8	14.0	8.8	13.5	6	19	12	2.5	10
6512 4-1/4	4	G1/4	14.0	8.8	16.4	7	20.5	15	2.5	14
6512 5-M5	5	M5	15.0	8.8	9.9	4	21	9	2	5
6512 6-M5	6	M5	16.0	11.7	13.2	4	22	12	2	8
6512 6-M6	6	M6	16.0	11.7	13.2	4.5	22.5	12	2.5	8
6512 6-1/8	6	G1/8	16.0	11.7	13.5	6	21	12	4	10
6512 6-1/4	6	G1/4	16.0	11.7	16.4	7	22	15	4	13
6512 8-1/8	8	G1/8	17.5	13.7	15.2	6	26	14	5	15
6512 8-1/4	8	G1/4	17.5	13.7	16.4	7	24.5	15	6	17
6512 8-3/8	8	G3/8	17.5	13.7	20.5	7	23	19	6	27
6512 10-1/4	10	G1/4	20.2	15.4	18.5	7	30	17	7	26
6512 10-3/8	10	G3/8	20.2	15.4	20.5	7	24.5	19	8	27
6512 10-1/2	10	G1/2	20.2	15.4	24.8	8	25	22	8	39
6512 12-1/4	12	G1/4	19.2	18.3	20.5	7	29.5	19	7	29
6512 12-3/8	12	G3/8	19.2	18.3	20.5	7	24	19	9	24
6512 12-1/2	12	G1/2	19.2	18.3	24.8	8	24.5	22	9	37
6512 14-3/8	14	G3/8	20.2	20.5	24.5	7	30.5	22	10	38
6512 14-1/2	14	G1/2	20.2	20.5	24.8	8	25.5	22	10	35
6512 16-1/2	16	G1/2	23.0	23.5	26.5	8	33.5	24	-	49

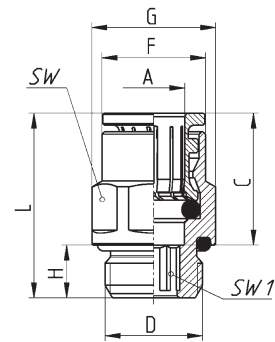

6463... 型快插管接头

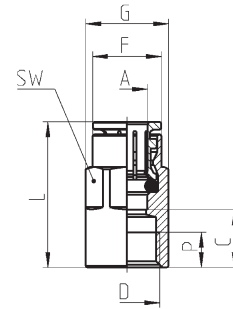

尺寸表									
型号	A	D	C	F	G	L	P (min)	SW	质量 (g)
6463 4-M5	4	M5	6.5	7.8	8.8	20.5	4.5	9	8
6463 4-1/8	4	G1/8	10	9	13	24	6	12	14
6463 5-1/8	5	G1/8	10	9.8	13	25	6	12	14
6463 6-1/8	6	G1/8	10	11.7	13	26	6	12	14
6463 6-1/4	6	G1/4	11.5	11.9	16.5	27.5	7	15	23
6463 8-1/8	8	G1/8	9.5	13.7	15.2	27	6	14	16
6463 8-1/4	8	G1/4	11.5	13.7	16.5	29	7	15	23
6463 10-1/4	10	G1/4	11.3	15.4	18.5	31.5	7	17	29

S6520... 型快插管接头

回转直角式

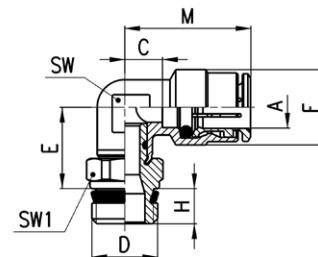

尺寸表										
型号	A	D	C	E	F	H	M	SW	SW1	质量 (g)
S6520 4-1/8	4	G1/8	3.5	14.5	9	5.5	17.5	8	12	17
S6520 4-1/4	4	G1/4	3.5	14.5	9	7	17.5	8	14	23
S6520 5-1/8	5	G1/8	5.5	14.5	10	5.5	20.5	9	12	17
S6520 5-1/4	5	G1/4	5.5	14.5	10	7	20.5	9	14	23
S6520 6-1/8	6	G1/8	4	15	12.7	5.5	20	9	12	20
S6520 6-1/4	6	G1/4	4	15	12.7	7	20	9	14	23
S6520 6-3/8	6	G3/8	4	15.5	12.7	8	20	9	19	33
S6520 8-1/8	8	G1/8	5	16	14.2	5.5	22.5	11	12	22
S6520 8-1/4	8	G1/4	5	16	14.2	7	22.5	11	14	26
S6520 8-3/8	8	G3/8	5	16.5	14.2	8	22.5	11	19	41
S6520 8-1/2	8	G1/2	5	17	14.2	9	22.5	11	22	48
S6520 10-1/4	10	G1/4	5.8	18.5	16.5	7	26	13	14	32
S6520 10-3/8	10	G3/8	5.8	19	16.5	8	26	13	19	43
S6520 10-1/2	10	G1/2	5.8	19.5	16.5	9	26	13	22	62
S6520 12-1/4	12	G1/4	7.3	20	19.5	7	26.5	15	17	49
S6520 12-3/8	12	G3/8	7.3	20	19.5	8	26.5	15	19	48
S6520 12-1/2	12	G1/2	7.3	20.5	19.5	9	26.5	15	22	70
S6520 14-3/8	14	G3/8	8.3	21	21.5	8	28.5	17	19	74
S6520 14-1/2	14	G1/2	8.3	21.5	21.5	9	28.5	17	22	78

6522... 型快插管接头

回转直角式

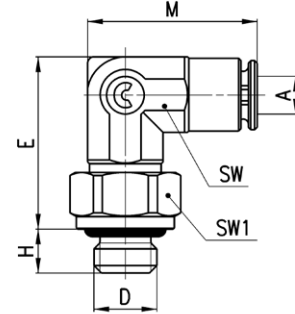

6000 系列快插管接头

尺寸表								
型号	A	D	E	H	M	SW	SW1	质量 (g)
6522 3-M3	3	M3	13.7	2.5	13.7	6	6	4 *
6522 3-M5	3	M5	13.7	3.5	13.7	6	8	5 •

* = 与所附 2611 型垫圈配套安装
• = 与所附 O 型圈配套安装

6522... 型快插管接头

回转直角式，与所附 O 型圈配套安装

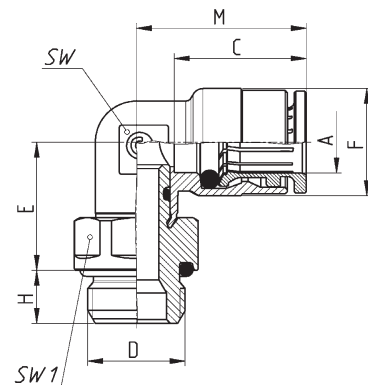

尺寸表										
型号	A	D	C	E	F	H	M	SW	SW1	质量 (g)
6522 4-M5	4	M5	14.0	12.5	9	4	17.5	8	8	12
6522 4-1/8	4	G1/8	14.0	14.5	9	6	17.5	8	12	15
6522 4-1/4	4	G1/4	14.0	15.5	9	7	17.5	8	15	25
6522 5-M5	5	M5	15.0	12.5	10	4	20.5	9	8	13
6522 6-M5	6	M5	16.0	13	12.7	4	20	9	10	14
6522 6-1/8	6	G1/8	16.0	15	12.7	6	20	9	12	19
6522 6-1/4	6	G1/4	16.0	16	12.7	7	20	9	15	27
6522 8-1/8	8	G1/8	17.5	16	14.2	6	22.5	11	12	22
6522 8-1/4	8	G1/4	17.5	17	14.2	7	22.5	11	15	28
6522 8-3/8	8	G3/8	17.5	17	14.2	7	22.5	11	19	45
6522 10-1/4	10	G1/4	20.2	19.5	16.5	7	26	13	15	41
6522 10-3/8	10	G3/8	20.2	19.5	16.5	7	26	13	19	45
6522 10-1/2	10	G1/2	20.2	20.5	16.5	8	26	13	22	53
6522 12-1/4	12	G1/4	19.2	20	19.5	7	26.5	15	17	51
6522 12-3/8	12	G3/8	19.2	20.5	19.5	7	26.5	15	19	56
6522 12-1/2	12	G1/2	19.2	21.5	19.5	8	26.5	15	22	58
6522 14-3/8	14	G3/8	20.2	21.5	21.5	7	28.5	17	19	53
6522 14-1/2	14	G1/2	20.2	22.5	21.5	8	28.5	17	22	61

S6500... 型快插管接头

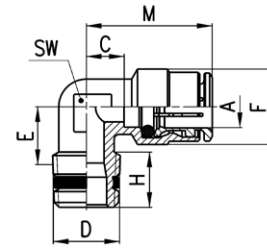

尺寸表									
型号	A	D	C	E	F	H	M	SW	质量 (g)
S6500 4-1/8	4	R1/8	3.5	8.5	9	7.5	17.5	8	9
S6500 4-1/4	4	R1/4	5	11.5	9	12	19	9	13
S6500 5-1/8	5	R1/8	5.5	8.5	10	7.5	20.5	9	13
S6500 5-1/4	5	R1/4	5.5	11.5	10	12	20.5	9	17
S6500 6-1/8	6	R1/8	4	9	12.7	7.5	20	9	15
S6500 6-1/4	6	R1/4	4	11.5	12.7	12	20	9	16
S6500 8-1/8	8	R1/8	5	10.5	14.2	6.5	22.5	11	18
S6500 8-1/4	8	R1/4	5	11.5	14.2	12.5	22.5	11	21
S6500 8-3/8	8	R3/8	7	13	14.2	11.5	24.5	12	25
S6500 10-1/4	10	R1/4	5.8	13	16.5	11.5	26	13	33
S6500 10-3/8	10	R3/8	5.8	13	16.5	12	26	13	33
S6500 12-1/4	12	R1/4	7.3	14.5	19.5	11	26.5	15	46
S6500 12-3/8	12	R3/8	7.3	13.5	19.5	11.5	26.5	15	39

6525... 型快插管接头

加长回转直角式

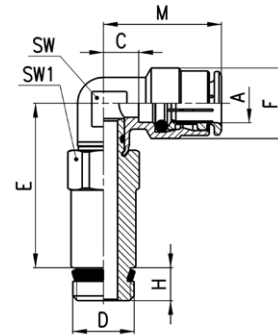

尺寸表										
型号	A	D	C	E	F	H	M	SW	SW1	质量 (g)
6525 6-1/8	6	G1/8	4	33.8	12.7	5.5	20	9	12	34
6525 6-1/4	6	G1/4	4	34	12.7	7	20	9	14	47
6525 8-1/8	8	G1/8	5	34.8	14.2	5.5	22.5	11	12	35
6525 8-1/4	8	G1/4	5	35	14.2	7	22.5	11	14	50

6621... 型快插管接头

铰接式，与所附 2661 型垫圈配套安装

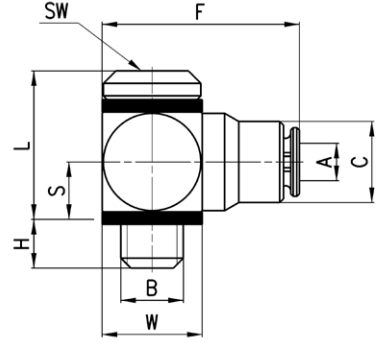

尺寸表

型号	A	B	C	F	H	L	S	W	SW	质量 (g)
6621 3-M3	3	M3	5.8	14.2	2.5	9.3	3.5	6	1.5	5
6621 3-M5	3	M5	6.5	16	3.2	11.9	4.8	8	2	6

6501 4-M5 型快插管接头

回转直角式，与所附 2661 型垫圈配套安装

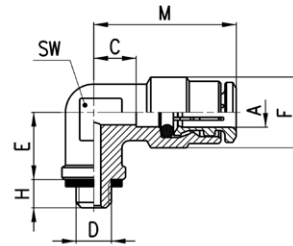

尺寸表

型号	A	D	C	E	F	H	M	SW	质量 (g)
6501 4-M5	4	M5	3.5	6	9	4	17.5	8	11

S6430... 型快插管接头

回转 T 型三通式

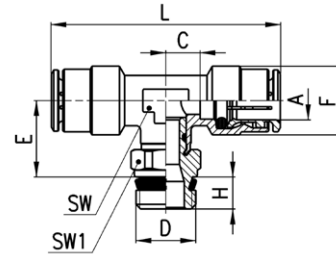

尺寸表										
型号	A	D	C	E	F	H	L	SW	SW1	质量 (g)
S6430 4-1/8	4	G1/8	3.5	14.5	9	5.5	35	8	12	18
S6430 5-1/8	5	G1/8	5.5	14.5	10	5.5	41	9	12	24
S6430 5-1/4	5	G1/4	5.5	14.5	10	7	41	9	14	30
S6430 6-1/8	6	G1/8	4	15	12.7	5.5	40	9	12	28
S6430 6-1/4	6	G1/4	4	15	12.7	7	40	9	14	33
S6430 8-1/8	8	G1/8	5	16	14.2	5.5	45	11	12	37
S6430 8-1/4	8	G1/4	5	16	14.2	7	45	11	14	42
S6430 8-3/8	8	G3/8	5	16.5	14.2	8	45	11	19	51
S6430 10-1/4	10	G1/4	5.8	18.5	16.5	7	52	13	14	56
S6430 10-3/8	10	G3/8	5.8	19	16.5	8	52	13	19	67
S6430 10-1/2	10	G1/2	5.8	19.5	16.5	9	52	13	22	85
S6430 12-1/4	12	G1/4	7.3	20	19.5	7	53	15	17	60
S6430 12-3/8	12	G3/8	7.3	20	19.5	8	53	15	19	65
S6430 12-1/2	12	G1/2	7.3	20.5	19.5	9	53	15	22	89
S6430 14-1/2	14	G1/2	8.3	21.5	21.5	9	57	17	22	88

6432... 型快插管接头

回转 T 型三通式

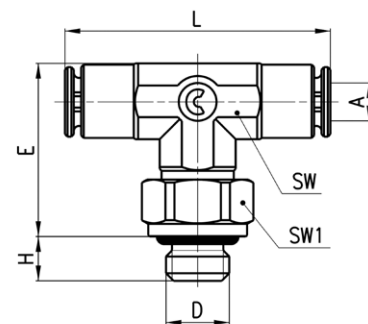

尺寸表									
型号	A	D	E	H	L	SW	SW1	质量 (g)	
6432 3-M3	3	M3	13.7	2.5	21.4	6	6	5	*
6432 3-M5	3	M5	13.7	3.5	21.4	6	8	6	•

* = 与所附 2661 型垫圈配套安装
• = 与所附 O 型圈配套安装

6432... 型快插管接头

回转 T 型三通式，与所附 O 型圈配套安装

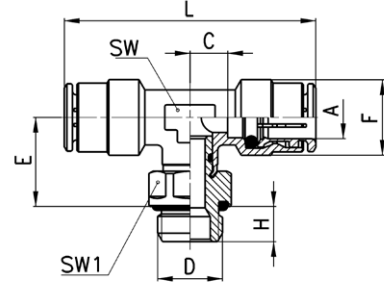

尺寸表										
型号	A	D	C	E	F	H	L	SW	SW1	质量 (g)
6432 4-M5	4	M5	3.5	12.5	9	4	35	8	8	14
6432 4-1/8	4	G1/8	3.5	14.5	9	6	35	8	12	19
6432 5-M5	5	M5	5.5	12.5	10	4	41	9	8	19
6432 6-1/8	6	G1/8	4	15	12.7	6	40	9	12	29
6432 6-1/4	6	G1/4	4	16	12.7	7	40	9	15	30
6432 8-1/8	8	G1/8	5	16	14.2	6	45	11	12	37
6432 8-1/4	8	G1/4	5	17	14.2	7	45	11	15	39
6432 8-3/8	8	G3/8	5	17	14.2	7	45	11	19	55
6432 10-1/4	10	G1/4	5.8	19.5	16.5	7	52	13	15	59
6432 10-3/8	10	G3/8	5.8	19.5	16.5	7	52	13	19	56
6432 12-1/4	12	G1/4	7.3	20	19.5	7	53	15	17	60
6432 12-3/8	12	G3/8	7.3	20.5	19.5	7	53	15	19	80

S6440... 型快插管接头

回转三通式

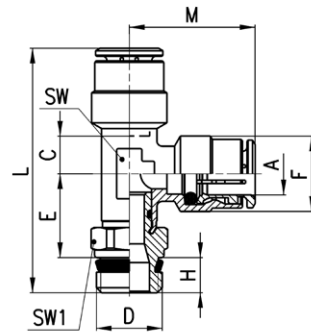

尺寸表											
型号	A	D	C	E	F	H	L	M	SW	SW1	质量 (g)
S6440 4-1/8	4	G1/8	3.5	14.5	9	5.5	37.5	17.5	8	12	23
S6440 5-1/8	5	G1/8	5.5	14.5	10	5.5	40.5	20.5	9	12	24
S6440 6-1/8	6	G1/8	4	15	12.7	5.5	40.5	20	9	12	26
S6440 6-1/4	6	G1/4	4	15	12.7	7	42	20	9	14	31
S6440 8-1/8	8	G1/8	5	16	14.2	5.5	44	22.5	11	12	37
S6440 8-1/4	8	G1/4	5	16	14.2	7	45.5	22.5	11	14	35
S6440 8-3/8	8	G3/8	5	16.5	14.2	8	47	22.5	11	19	52
S6440 10-1/4	10	G1/4	5.8	18.5	16.5	7	51.5	26	13	14	43
S6440 10-3/8	10	G3/8	5.8	18.5	16.5	8	53	26	13	19	66
S6440 12-3/8	12	G3/8	7.3	19.5	19.5	8	54.5	26.5	15	19	65
S6440 14-1/2	14	G1/2	8.3	21.5	21.5	9	59	28.5	17	22	88

6442... 型快插管接头



回转三通式

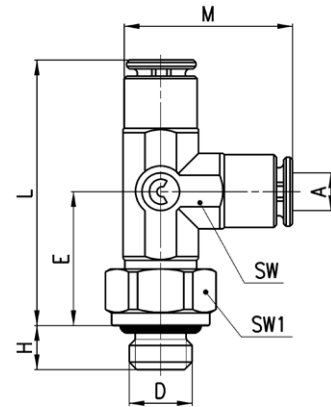

尺寸表									
型号	A	D	E	H	L	M	SW	SW1	质量 (g)
6442 3-M3	3	M3	10.7	2.5	21.4	13.7	6	6	5
6442 3-M5	3	M5	12.2	3.5	21.4	13.7	6	8	6

* = 与所附 2661 型垫圈配套安装
 ● = 与所附 O 型圈配套安装

6442... 型快插管接头



回转三通式，与所附 O 型圈配套安装

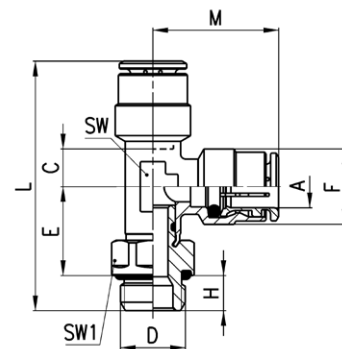

尺寸表											
型号	A	D	C	E	F	H	L	M	SW	SW1	质量 (g)
6442 4-M5	4	M5	3.5	12.5	9	4	34	17.5	8	8	18
6442 4-1/8	4	G1/8	3.5	14.5	9	6	38	17.5	8	12	19
6442 5-M5	5	M5	5.5	12.5	10	4	36.5	20.5	9	8	19
6442 6-1/8	6	G1/8	4	15	12.7	6	41	20	9	12	26
6442 6-1/4	6	G1/4	4	16	12.7	7	43	20	9	15	36
6442 8-1/8	8	G1/8	5	16	14.2	6	44.5	22.5	11	12	31
6442 8-1/4	8	G1/4	5	17	14.2	7	46.5	22.5	11	15	42
6442 8-3/8	8	G3/8	5	17	14.2	7	46.5	22.5	11	19	50
6442 10-1/4	10	G1/4	5.8	19.5	16.5	7	52.5	26	13	15	46
6442 10-3/8	10	G3/8	5.8	19.5	16.5	7	52.5	26	13	19	66
6442 12-1/4	12	G1/4	7.3	20	16.5	7	53.5	26.5	15	17	73
6442 12-3/8	12	G3/8	7.3	20.5	19.5	7	54	26.5	15	19	64

6452... 型快插管接头

回转 Y 型三通式

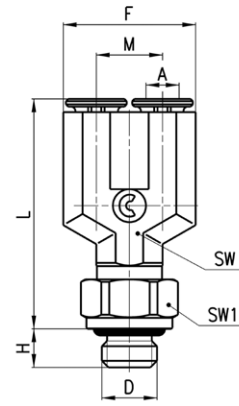

尺寸表										
型号	A	D	F	H	L	M	SW	SW1	质量 (g)	
6452 3-M3	3	M3	12	2.5	20.9	6	6	6	6	*
6452 3-M5	3	M5	12	3.5	20.9	6	6	8	7	●

* = 与所附 2661 型垫圈配套安装
● = 与所附 O 型圈配套安装

6451 - S6450... 型快插管接头

回转 Y 型三通式

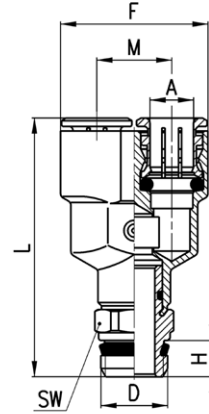

尺寸表										
型号	A	D	F	H	L	M	SW	质量 (g)		
6451 4-M5	4	M5	18	4	26.5	9	-	17	*	
6451 6-M5	6	M5	24.5	4	29.5	12.5	-	27	*	
S6450 4-1/8	4	G1/8	18	5.5	38	9	12	23		
S6450 6-1/8	6	G1/8	24.5	5.5	41.5	12.5	12	33		
S6450 8-1/8	8	G1/8	28.5	5.5	48.5	14.5	14	48		
S6450 8-1/4	8	G1/4	28.5	7	50	14.5	14	50		

* = 非回转式，与所附 2661 型垫圈
配套安装

6622... 型快插管接头

铰接式，与所附 O 型圈配套安装

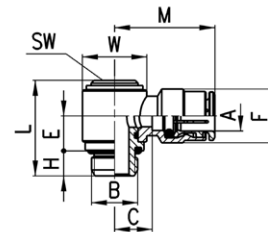

尺寸表											
型号	A	B	C	E	F	H	L	M	SW	W	质量 (g)
6622 4-M5	4	M5	4	5.7	8.8	4	15.8	18	2.5	Ø 8	10
6622 4-1/8	4	G1/8	7.5	10.2	9	5	25	21.5	4	Ø 14	22
6622 6-1/8	6	G1/8	8	10.2	12.7	5	25	24	4	Ø 14	24
6622 6-1/4	6	G1/4	10	9.1	12.7	6	25.3	26	5	Ø 18	35
6622 8-1/8	8	G1/8	8	10.2	14.2	5	25	25.5	4	Ø 14	28
6622 8-1/4	8	G1/4	10	9.1	14.2	6	25.3	27.5	5	Ø 18	39
6622 10-1/4	10	G1/4	8.8	9.1	16.5	6	25.3	29	5	Ø 18	42

6632... 型快插管接头

铰接式，与所附 O 型圈配套安装

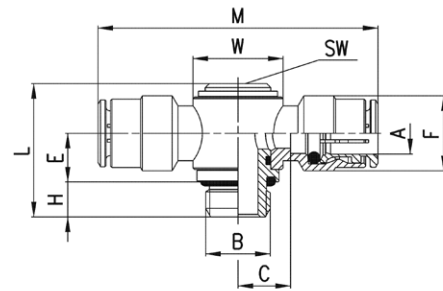

尺寸表												
型号	A	B	C	E	F	H	L	M	W	SW	质量 (g)	
6632 4-1/8	4	G1/8	7.5	10.2	9	5	25	43	∅14	4	24	
6632 6-1/8	6	G1/8	8	10.2	12.7	5	25	48	∅14	4	33	
6632 6-1/4	6	G1/4	10	9.1	12.7	6	25.3	52	∅18	5	35	
6632 8-1/8	8	G1/8	8	10.2	14.2	5	25	51	∅14	4	39	
6632 8-1/4	8	G1/4	10	9.1	14.2	6	25.3	55	∅18	5	40	
6632 10-1/4	10	G1/4	8.8	9.1	16.5	6	25.3	58	∅18	5	50	

6620... 型快插管接头

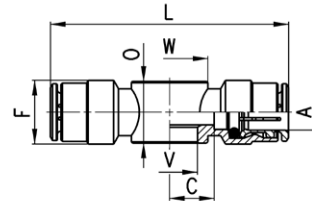

尺寸表										
型号	A	C	F	L	O	V	W	质量 (g)	可与下列产品配合使用	
6620 4-M5	4	5	9	38	9	5.1	∅9	13	SCU, SVU, SCO...	
6620 4-1/8	4	7.5	9	43	14.5	9.8	∅14	19	1631, 1635, SCU, SVU, SCO...	
6620 6-1/8	6	8	12.7	48	14.5	9.8	∅14	24	1631, 1635, SCU, SVU, SCO...	
6620 6-1/4	6	10	12.7	52	14.5	13.2	∅18	26	1631, 1635, SCU, SVU, SCO...	
6620 8-1/8	8	8	14.2	51	14.5	9.8	∅14	32	1631, 1635, SCU, SVU, SCO...	
6620 8-1/4	8	10	14.2	55	14.5	13.2	∅18	34	1631, 1635, SCU, SVU, SCO...	

1631... 型管接头

具体的产品代号、图形和尺寸表请详见 8/2.05.08



型号
1631 01-
1631 02-
1631 03-

Drawings and dimensions on page 2.05.09

6610... 型快插管接头

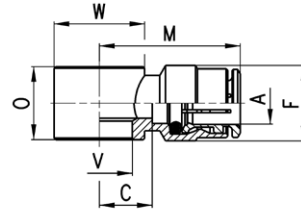

尺寸表									
型号	A	C	F	M	O	V	W	质量 (g)	可与下列产品配合使用
6610 4-M5	4	5	9	19	9	5.1	Ø 9	9	1631
6610 4-M6	4	5	9	19	9	5.1	Ø 9	8	SCU, SVU, SCO...
6610 4-1/8	4	7.5	9	21.5	14.5	9.8	Ø 14	14	1631, 1635, SCU, SVU, SCO...
6610 5-M5	5	5	10	20	9	5.1	Ø 9	9	1631
6610 5-M6	5	5	10	20	9	5.1	Ø 9	8	SCU, SVU, SCO...
6610 5-1/8	5	8	10	23	14.5	9.8	Ø 14	16	1631, 1635, SCU, SVU, SCO...
6610 6-M5	6	6.5	12.7	22.5	9	5.1	Ø 10	12	1631
6610 6-M6	6	6.5	12.7	22.5	9	5.1	Ø 10	12	SCU, SVU, SCO...
6610 6-1/8	6	8	12.7	24	14.5	9.8	Ø 14	16	1631, 1635, SCU, SVU, SCO...
6610 6-1/4	6	10	12.7	26	14.5	13.2	Ø 18	19	1631, 1635, SCU, SVU, SCO...
6610 8-1/8	8	8	14.2	25.5	14.5	9.8	Ø 14	19	1631, 1635, SCU, SVU, SCO...
6610 8-1/4	8	10	14.2	27.5	14.5	13.2	Ø 18	22	1631, 1635, SCU, SVU, SCO...
6610 8-3/8	8	11	14.2	28.5	14.5	16.7	Ø 21	23	1631, 1635, SCU, SVU, SCO...
6610 10-1/4	10	8.8	16.5	29	14.5	13.2	Ø 18	22	1635, SCU, SVU, SCO...
6610 10-3/8	10	10.3	16.5	30.5	14.5	16.7	Ø 21	23	1635, SCU, SVU, SCO...
6610 12-1/2	12	12.8	16.5	32	14.5	21	Ø 26	37	1635

6811... 型管接头

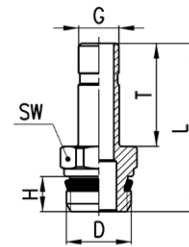

尺寸表							
型号	G	D	H	T	L	SW	质量 (g)
6811 4-M5	4	M5	4	16.5	24.5	8	3 *
6811 4-1/8	4	G1/8	5.5	16.5	27.8	12	10
6811 5-1/8	5	G1/8	5.5	18	29.3	12	9
6811 5-1/4	5	G1/4	7	18	31	14	11
6811 6-1/8	6	G1/8	5.5	18	29.3	12	10
6811 6-1/4	6	G1/4	7	18	31	14	12
6811 8-1/8	8	G1/8	5.5	20.5	31.8	12	12
6811 8-1/4	8	G1/4	7	20.5	33.5	14	13
6811 10-1/4	10	G1/4	7	23	36	14	16
6811 10-3/8	10	G3/8	8	23	37.3	19	25
6811 12-3/8	12	G3/8	8	24	38.3	19	25
6811 14-1/2	14	G1/2	9	28	44	22	39

* = 与所附 O 型圈配套使用

S6110... 型快插管接头

回转式

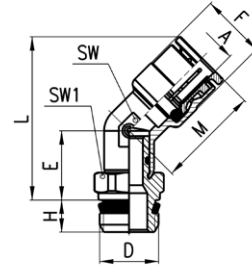

尺寸表										
型号	A	D	E	F	H	L	M	SW	SW1	质量 (g)
S6110 6-1/8	6	G1/8	14	12.7	5.5	32.5	20.5	11	12	21
S6110 6-1/4	6	G1/4	14	12.7	7	34.5	20.5	11	14	25
S6110 8-1/8	8	G1/8	14	14.2	5.5	32.5	22.5	11	12	21
S6110 8-1/4	8	G1/4	14	14.2	7	34.5	22.5	11	14	26
S6110 8-3/8	8	G3/8	14.5	14.2	8	35	22.5	11	19	38
S6110 10-1/4	10	G1/4	15.5	16.5	7	39.5	26.5	15	17	39
S6110 10-3/8	10	G3/8	15.5	16.5	8	39.5	26.5	15	19	44
S6110 10-1/2	10	G1/2	16	16.5	9	40	26.5	15	22	57
S6110 12-1/4	12	G1/4	15.5	19.5	7	40.5	26.5	15	17	41
S6110 12-3/8	12	G3/8	15.5	19.5	8	40.5	26.5	15	19	46
S6110 12-1/2	12	G1/2	16	19.5	9	41	26.5	15	22	59

6590... 型快插管接头

穿板式

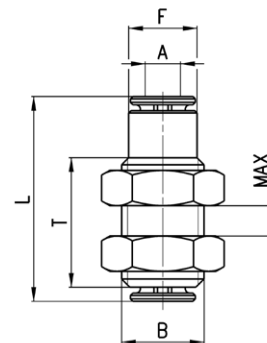
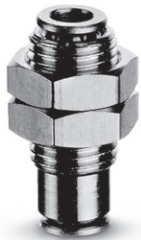

尺寸表							
型号	A	B	F	L	MAX	T	质量 (g)
6590 3	3	M7x0.75	5.8	18.4	5	11.4	4

6590... 型快插管接头

穿板式

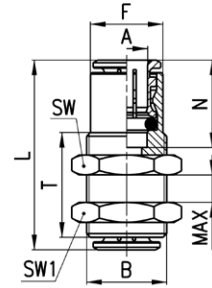

尺寸表										
型号	A	B	F	L	N	MAX	SW	SW1	T	质量 (g)
6590 4	4	M10x1	8.8	29	14	10.5	14	14	20	16
6590 5	5	M12x1	9.8	31	15	10.5	17	17	20	25
6590 6	6	M14x1	12.5	33	16	10.5	17	17	20	28
6590 8	8	M16x1	14.5	36	17.5	11.5	19	19	21	35
6590 10	10	M18x1	16.3	41.5	20.2	13	22	22	23.5	51
6590 12	12	M20x1	18.8	39.5	19.2	14.5	24	24	25	56
6590 14	14	M22x1	20.5	41.5	20.2	17.5	27	27	30	82

6580... 型快插管接头

挡圈符合 UNI 7435 和 DIN 471 标准

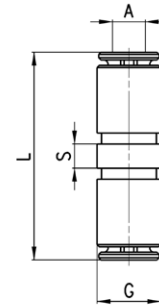

尺寸表					
型号	A	G	L	S	质量 (g)
6580 3	3	5.8	19.9	2.2	2

6580... 型快插管接头

挡圈符合 UNI 7435 和 DIN 471 标准

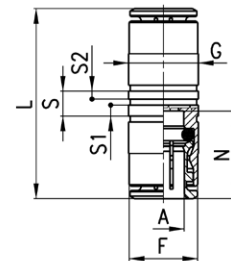

尺寸表									
型号	A	F	G	L	N	S	S1	S2	质量 (g)
6580 4	4	8.4	9	29	14	5	2.2	1.6	11
6580 5	5	9.4	10	31	15	5	2.2	1.6	15
6580 6	6	11.7	12	34	16	5	2.2	1.6	16
6580 8	8	13.7	14	37	17.5	5	2.2	1.6	23
6580 10	10	15.4	17	41.5	20.2	5	2.2	1.6	33
6580 12	12	18.3	19	39.5	19.2	5.2	2.2	1.6	40
6580 14	14	20.5	21	41.5	20.2	5.2	2.2	1.6	47
6580 16	16	-	47	47	23	-	-	-	60

6580... 型快插管接头

变径式

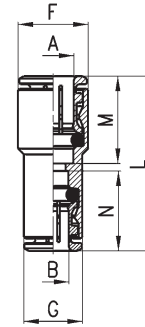

尺寸表									
型号	A	B	F	G	L	M	N	质量 (g)	
6580 6-4	6	4	12	9	31.5	16	14	12	
6580 8-6	8	6	14	12.2	35	17.5	16	19	
6580 10-8	10	8	16	14	39	20	17.5	25	
6580 12-10	12	10	19	16	40.5	19	20	35	

6593... 型快插管接头

穿板式

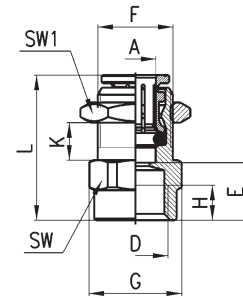

尺寸表												
型号	A	D	E	F	G	H	L	K (max)	K (min)	SW	SW1	质量 (g)
6593 6-1/8	6	G1/8	10	M12x1	16.4	6	24.5	8.5	2	15	17	19
6593 6-1/4	6	G1/4	11.5	M12x1	18.5	7	26	6.5	2	17	17	22
6593 8-1/8	8	G1/8	10	M15x1	18.5	6	27	9.5	2	17	19	26
6593 8-1/4	8	G1/4	11.5	M15x1	18.5	7	28.5	9.5	2	17	19	26
6593 10-3/8	10	G3/8	12.8	M18x1	24.5	8	32.5	12	2	22	22	43

6550... 型快插管接头

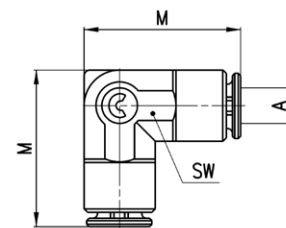

尺寸表				
型号	A	M	SW	质量 (g)
6550 3	3	13.7	6	3

6550... 型快插管接头

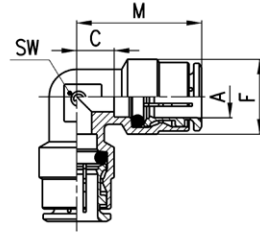

尺寸表						
型号	A	C	F	M	SW	质量 (g)
6550 4	4	3.5	9	17.5	8	8
6550 5	5	5.5	10	20.5	9	15
6550 6	6	4	12.7	20	9	17
6550 8	8	5	14.2	22.5	11	22
6550 10	10	5.8	16.5	26	13	30
6550 12	12	7.3	19.5	26.5	15	44
6550 14	14	8.3	21.5	28.5	17	71

6540... 型快插管接头

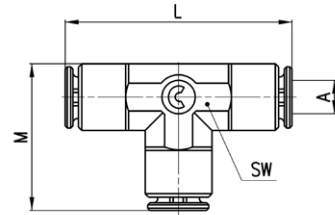

尺寸表					
型号	A	L	M	SW	质量 (g)
6540 3	3	21.4	13.7	6	4

6540... 型快插管接头

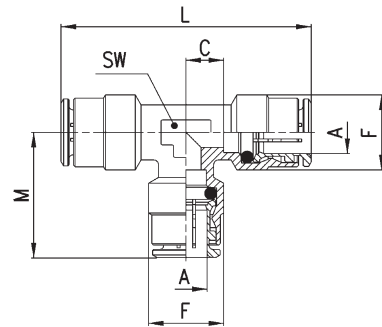

尺寸表							
型号	A	C	F	L	M	SW	质量 (g)
6540 4	4	3.5	9	35	17.5	8	14
6540 5	5	5.5	10	41	20.5	9	21
6540 6	6	4	12.7	40	20	9	24
6540 8	8	5	14.2	45	22.5	11	32
6540 10	10	5.8	16.5	52	26	13	43
6540 12	12	7.3	19.5	53	26.5	15	60
6540 14	14	8.3	21.5	57	28.5	17	75

6600... 型快插管接头

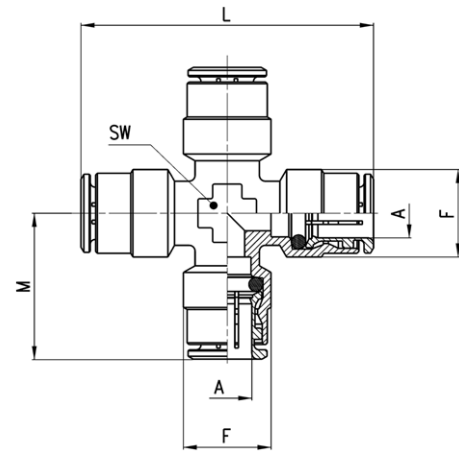

尺寸表						
型号	A	F	L	M	SW	质量 (g)
6600 4	4	9	38	19	9	26
6600 5	5	10	41	20.5	9	29
6600 6	6	12.7	44	22	10	35
6600 8	8	14.2	49	24.5	12	50
6600 10	10	16.5	55	27.5	14	63
6600 12	12	19.5	56	28	16	84

6560... 型快插管接头

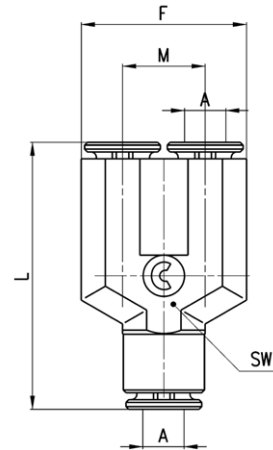
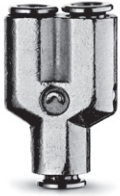

尺寸表						
型号	A	F	L	M	SW	质量 (g)
6560 3	3	12	20.4	6	6	5

6560... 型快插管接头

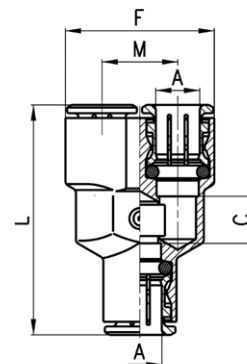

尺寸表						
型号	A	C	F	L	M	质量 (g)
6560 4	4	5	18	33	9	19
6560 6	6	7	24.5	39	12.5	30
6560 8	8	9	28.5	44	14.5	42
6560 10	10	15.5	32	53.5	16	63

6700... 型快插管接头

埋入式



S* = 金属基座公差范围 (0 ~ +0.05)
S* = 合成材料基座公差范围 (-0.02 ~ +0.03)

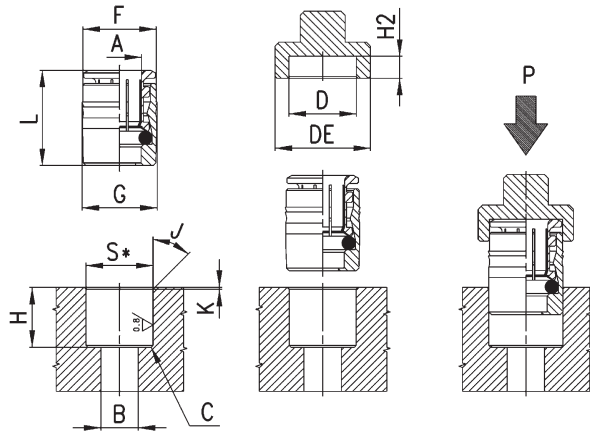

尺寸表																
型号	A	B	C	D	DE	F	G	H	H2 (+0.1/0)	J	K	L	P min (Kg)	P max (Kg)	S (+0.01/-0.04)	质量 (g)
6700 3	3	2	0.5x45°	6.1	11	5.9	6.2	6.3	2.6	30°	0.3	9.2	80	350	6	1
6700 4	4	3.5	0.5x45°	8.8	14	8.6	9	11	3.3	15°	0.5	14.5	200	360	8.75	4
6700 5	5	3.5	0.5x45°	9.8	15	9.6	10	11.5	3.3	15°	0.5	15.5	230	450	9.75	5
6700 6	6	4	0.5x45°	12	17	11.8	12.2	12	3.8	15°	0.5	16.5	160	570	11.95	8
6700 8	8	6	0.5x45°	14	19	13.8	14.2	14	3.3	15°	0.5	18	140	400	13.95	11
6700 10	10	8	0.5x45°	16	21	15.8	16.2	16.5	3.5	15°	0.5	20.5	150	650	15.95	15

6750... 型快插管接头

封堵

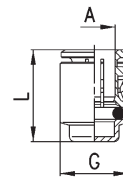

尺寸表				
型号	A	G	L	质量 (g)
6750 4	4	8.8	15	4
6750 6	6	11.8	17	7
6750 8	8	13.8	18.5	9
6750 10	10	15.8	21	12
6750 12	12	17.8	20	15

6850... 型快插管接头

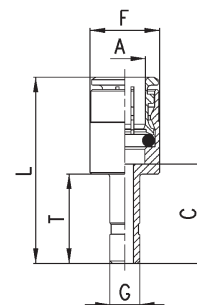

尺寸表							
型号	A	G	C	F	L	T	质量 (g)
6850 6-4	6	4	17.5	12.7	33.5	16.5	11
6850 8-6	8	6	19	14	36.5	18	15

6800... 型快插管接头

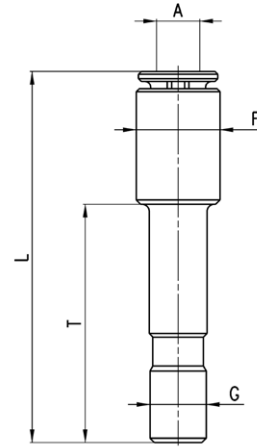

尺寸表						
型号	A	F	G	L	T	质量 (g)
6800 3-4	3	5.8	4	26	16.5	2

6800... 型快插管接头

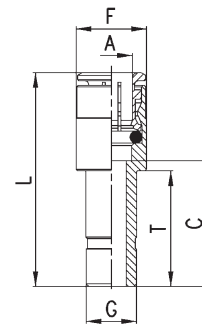

尺寸表							
型号	A	G	C	F	L	T	质量 (g)
6800 4-5	4	5	19	9	33	18	8
6800 4-6	4	6	15.5	9	29.5	18	9
6800 4-8	4	8	18	9	32	20.5	10
6800 5-6	5	6	19	10	34	18	11
6800 5-8	5	8	18	10	33	20.5	12
6800 6-8	6	8	18	12.7	34	20.5	12
6800 6-10	6	10	20.5	12.7	36.5	23	17
6800 6-12	6	12	17.5	12.7	33.5	24	21
6800 8-10	8	10	20.5	14	38	23	15
6800 8-12	8	12	21.5	14	39	24	22
6800 10-12	10	12	20.3	16.5	40.5	24	27
6800 10-14	10	14	24.3	16.5	44.5	28	33
6800 12-14	12	14	24.3	18.8	45.5	28	27

6950... 型快插管接头

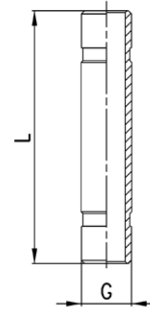

尺寸表			
型号	G	L	质量 (g)
6950 4	4	32.5	3
6950 6	6	35.5	4
6950 8	8	40.5	7
6950 10	10	46	10
6950 12	12	48	13
6950 14	14	52	17

6555... 型快插管接头

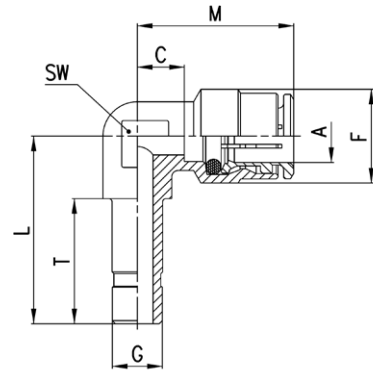

尺寸表									
型号	A	G	C	L	F	T	M	SW	质量 (g)
6555 4-4	4	4	3.5	22	9	16.5	17.5	9	8
6555 6-6	6	6	4	24.5	12.7	18	20	9	14
6555 8-8	8	8	5	27.5	14.2	20	22.5	11	21
6555 10-10	10	10	5.8	32	16.5	23	26	13	26

6708... 型快插管接头护套

黑色
自熄性材料 (等级 UL94-V0)

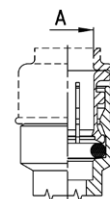
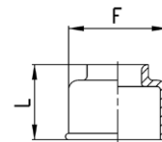

尺寸表				
型号	A	F	L	质量 (g)
6708 4	4	10.7	10.7	1
6708 5	5	11.7	11	1
6708 6	6	13.7	11.5	1
6708 8	8	15.7	12.5	1
6708 10	10	18.5	13	1
6708 12	12	20.7	15	2
6708 14	14	23.7	15	2

6900... 型快插管接头封堵

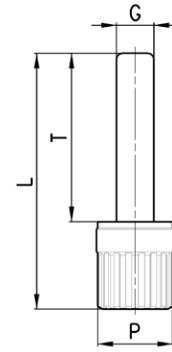

尺寸表					
型号	G	L	P	T	质量 (g)
6900 3	3	20.5	6	13.5	1

6900... 型快插管接头封堵

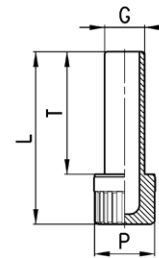

尺寸表					
型号	G	L	P	T	质量 (g)
6900 4	4	29	8	20	1
6900 5	5	29.5	8	20.5	1
6900 6	6	31.5	8	22.5	1
6900 8	8	34.5	12	24.5	2
6900 10	10	37	12	27	2
6900 12	12	40.5	16	28.5	3
6900 14	14	42.5	16	30.5	3

辅助拔管工具

可用于连接管外径 4 至 12 的快插管接头的辅助拔管



型号
SP