

# Cilindros perfil en aluminio Serie 61

Simple y doble efecto, magnéticos, amortiguados  
Versiones estándar, baja fricción, baja temperatura y tandem  
Ø 32, 40, 50, 63, 80, 100, 125 mm



CILINDROS SERIE 61



Los cilindros serie 61 han sido diseñados para cumplir con las dimensiones establecidas en los estándares del ISO 15552. Sobre el perfil de aluminio existen dos ranuras, disponibles en tres lados del perfil, donde es posible montar directamente el sensor de proximidad para la detección de la posición del pistón. Esta ranura se puede cubrir con un perfil.

Esta serie es dotada de amortiguadores de carrera regulables. Adicionalmente estos cilindros están fabricados con amortiguadores mecánicos, con la finalidad de reducir el impacto del émbolo al final de su carrera.

- » Conforme a la norma ISO 15552 y con las previas DIN/ISO 6431 - VDMA 24562
- » Vástago en acero inox rolado
- » Amortiguación neumática regulable
- » Versiones especiales disponibles

#### TANDEM:

- » Doble fuerza de empuje y en tracción

#### BAJA FRICCIÓN:

- » Fuerza de fricción reducida en mas del 40%  
BAJA

#### TEMPERATURA:

- » Versiones para -40°C y para -50°C

#### VERSION G PARA APLICACIONES DE POLVO:

- » Alta resistencia para residuos de polvo (hormigón, resina, fango, residuos de madera, etc...)

## CARACTERÍSTICAS GENERALES

<b>Tipo de construcción</b>	con tirantes (en el interior del perfil)
<b>Funcionamiento</b>	doble efecto, simple efecto, tandem. Versión de baja fricción: sólo doble efecto
<b>Materiales</b>	estándar: cabezales y pistón en AL, vástago en acero inox AISI 420B rolado, tuerca vástago en acero zincado, camisa perfil de AL anodizado, tirantes y tuercas tirantes en acero zincado, juntas PU; baja fricción: materiales estándar con juntas pistón en NBR y junta vástago en NBR (junta vástago en FKM bajo pedido) baja temperatura: material estándar con vástago en acero inox AISI 420B cromado, anillo limpiador del vástago en latón; tirantes en acero inox AISI 420B, tuercas en acero inox AISI 303, juntas pistón en PU y junta vástago en NBR
<b>Tipo de fijación</b>	con tirantes, brida anterior brida posterior, patas, charnela intermedia, charnela anterior y posterior, charnela combinada, charnela basculante
<b>Carreras min - max</b>	10 ÷ 2500 mm
<b>Temperatura de trabajo</b>	estándar y baja fricción: 0°C ÷ 80°C (con aire seco - 20°C) baja temperatura (versión -40°C): -40°C ÷ 60°C (con aire seco -40°C) baja temperatura (versión -50°C): -50°C ÷ 60°C (con aire seco -50°C)
<b>Presión de trabajo</b>	1 ÷ 10 bar (estándar y baja temperatura); 0,1 ÷ 10 bar (baja fricción)
<b>Velocidad</b>	10 ÷ 1000 mm/seg, sin carga (estándar y baja temperatura); 5 ÷ 1000 mm/seg, sin carga (baja fricción)
<b>Fluido</b>	aire filtrado, sin lubricación. Para versiones estándar únicamente: si es usado aire lubricado, es recomendado usar aceite ISOVG32. Una vez aplicado la lubricación nunca deberá ser interrumpida.

**TABLA CARRERAS ESTÁNDAR PARA CILINDROS SERIE 61**

■ = Simple efecto (estándar y baja temperatura)    ✕ = Doble efecto (estándar, baja fricción y baja temperatura)  
 Otras carreras hasta 2500 mm están disponibles bajo pedido.

CARRERAS ESTÁNDAR														
Ø	25	50	75	80	100	125	150	160	200	250	300	320	400	500
32	■ ✕	■ ✕	■ ✕	✕	✕	✕	✕	✕	✕	✕	✕	✕	✕	✕
40	■ ✕	■ ✕	■ ✕	✕	✕	✕	✕	✕	✕	✕	✕	✕	✕	✕
50	■ ✕	■ ✕	■ ✕	✕	✕	✕	✕	✕	✕	✕	✕	✕	✕	✕
63	■ ✕	■ ✕	■ ✕	✕	✕	✕	✕	✕	✕	✕	✕	✕	✕	✕
80	■ ✕	■ ✕	■ ✕	✕	✕	✕	✕	✕	✕	✕	✕	✕	✕	✕
100		■ ✕	■ ✕	✕	✕	✕	✕	✕	✕	✕	✕	✕	✕	✕
125		✕	✕	✕	✕	✕	✕	✕	✕	✕	✕	✕	✕	✕

**EJEMPLO DE CODIFICACIÓN**

<b>61</b>	<b>M</b>	<b>2</b>	<b>P</b>	<b>050</b>	<b>A</b>	<b>0200</b>	
-----------	----------	----------	----------	------------	----------	-------------	--

<b>61</b>	SERIE
<b>M</b>	VERSIÓN: M = estándar, magnético - L = baja fricción
<b>2</b>	FUNCIONAMIENTO: 1 = simple efecto, resorte frontal (ø32 ÷ ø100) 2 = doble efecto, amortiguación anterior y posterior 3 = doble efecto, sin amortiguación 4 = doble efecto, amortiguación posterior 5 = doble efecto, amortiguación anterior 6 = doble efecto, vástago pasante, amortiguación anterior y posterior 7 = simple efecto, vástago pasante 8 = doble efecto, vástago pasante, sin amortiguación
<b>P</b>	MATERIALES P = ver la tabla CARACTERÍSTICAS GENERALES en la página 1/1.25.01 R = tirantes inox AISI 420B - tuercas tirantes inox AISI 303 - otros materiales (ver tabla en la pág. 1/1.25.01) C = vástago inox AISI 303 rolado - tuerca vástago inox AISI 304 U = vástago inox AISI 303 rolado - tuerca vástago inox AISI 304 - tirantes inox AISI 420B - tuercas tirantes inox AISI 303 W = vástago inox AISI 304 rolado - tuerca vástago inox AISI 304 - tirantes inox AISI 420B - tuercas tirantes inox AISI 303 Z = vástago inox AISI 420B cromado - tuerca vástago inox AISI 304 - tirantes inox AISI 420B - tuercas tirantes inox AISI 303 juntas para bajas temperaturas (-40°C), anillo limpiador del vástago en latón [ excluido Ø 125 ] Y = vástago inox AISI 420B cromado - tuerca vástago inox AISI 304 - tirantes inox AISI 420B - tuercas tirantes inox AISI 303 juntas para bajas temperaturas (-50°C), anillo limpiador del vástago en latón [ excluido Ø 125 ]
<b>050</b>	DIÁMETRO: 032 = 32 mm - 040 = 40 mm - 050 = 50 mm - 063 = 63 mm - 080 = 80 mm - 100 = 100 mm - 125 = 125 mm
<b>A</b>	CONTRUCCIÓN: A = estándar con tuerca para vástago - RL = cilindro con bloqueo vástago
<b>0200</b>	CARRERA (ver tabla)
	= estándar      V = junta vástago FKM      N = tandem      R = junta vástago NBR      W = todas (las juntas FKM + 130°C      C = recubierto con PU. Color: Gris *      L = sin junta vástago (sólo alim. trasera) ** ( _ _ ) = vástago prolongado de _ _ _ mm      G = con anillo limpiador vástago latón (vást. inox AISI 420B cromado, junta vást. NBR)
	* Para la versión C, disponible bajo pedido, se ruega contacten nuestros técnicos. ** La posibilidad de quitar la junta del vástago reduce aún más la fuerza de fricción en aplicaciones en empuje.

NB: todos los cilindros doble efecto están también disponibles en versiones de baja fricción.

**SÍMBOLOS NEUMÁTICOS**

Abajo están ilustrados los símbolos neumáticos indicados en el EJEMPLO DE CODIFICACIÓN.

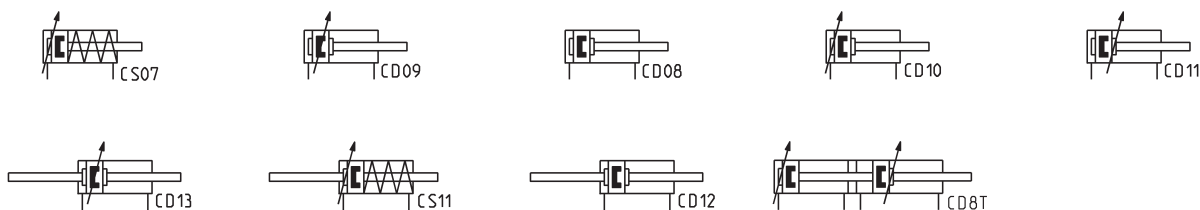

**Cilindros Serie 61 de baja fricción – EJEMPLOS DE APLICACIÓN**

CILINDROS SERIE 61

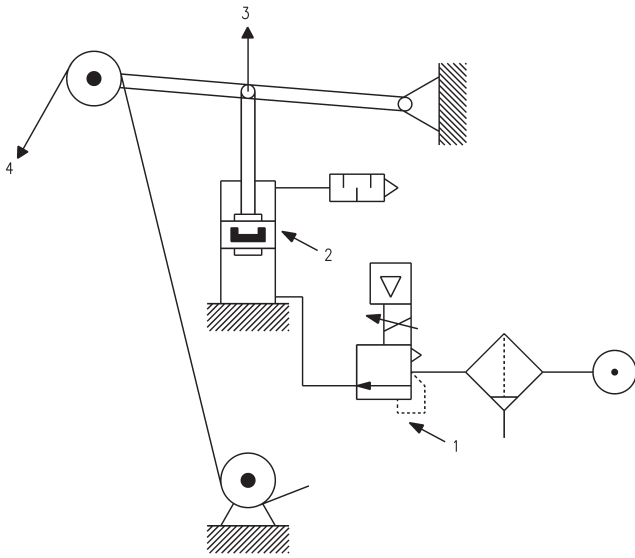

**CILINDRO DE EMPUJE**

**NOTAS DEL DIBUJO:**

- 1. Regulador de presión de precisión o regulador electro-neumático
- 2. Cilindro de baja fricción
- 3. Fuerza de la dirección
- 4. Banda

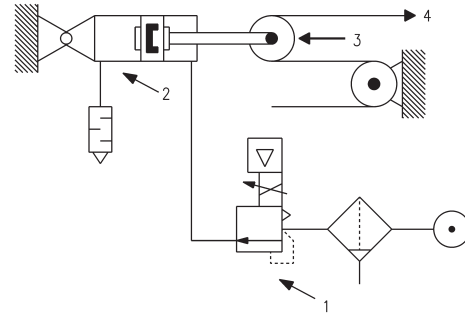

**CILINDROS EN TRACCIÓN**

Nota: para poder alcanzar el máximo rendimiento, se recomienda conectar el regulador de presión de precisión o un regulador electro-neumático con el cilindro de baja fricción, como se muestra en el dibujo.

**Cilindros Serie 61 baja temperatura - detalle**

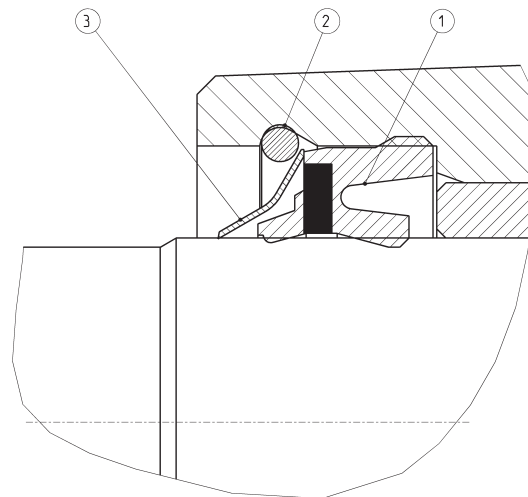
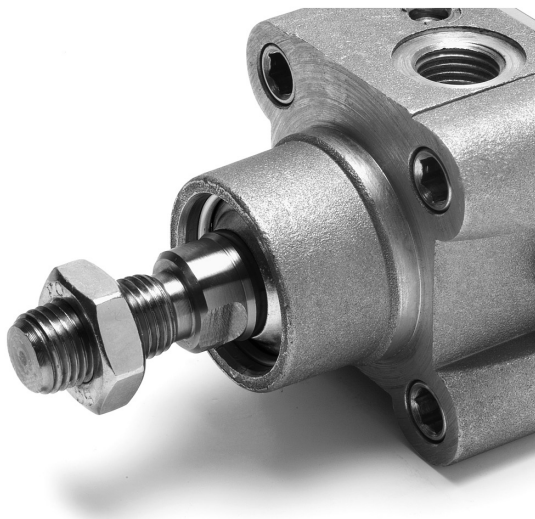

- 1 = junta vástago
- 2 = anillo elástico
- 3 = raspador metálico

**ACCESORIOS PARA CILINDROS SERIE 61**



Horquilla + rótula para vástago Mod. GY



Tuerca para vástago Mod. U



Perno Mod. S

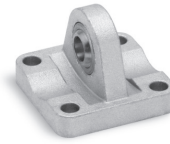

Amarre con charnela y rótula Mod. R



Conjunto compensador Mod. GKF



Horquilla esférica para vástago Mod. GA

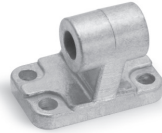

Soporte 90° para basculante Mod. ZC

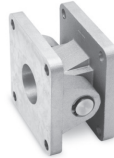

Combinación de accesorios Mod. C+L+S

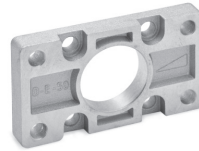

Amarre con brida ant. y post. Mod. D-E



Accesorio autoalineable Mod. GK



Amarre + basculante intermedio Mod. F



Amarre con patas Mod. B

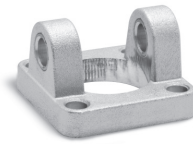

Amarre + charn. hembra ant. Mod. H y C-H

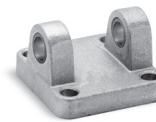

Amarre + charn. hembra post. Mod. C y C-H

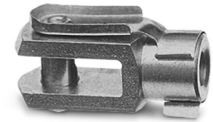

Horquilla para vástago Mod. G

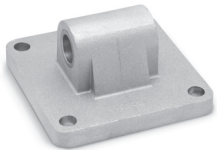

Amarre + charnela macho post. Mod. L



Llave para el desmontaje de cilindros Ø 80 y 100



Soporte para basculante int. Mod. BF



Todos los accesorios se proveen por separado al cilindro, excepto las tuercas Mod U.

### Cilindros Serie 61

NOTA: en la versión simple efecto las cuotas ZJ y L2 se incrementarán de 25 mm.

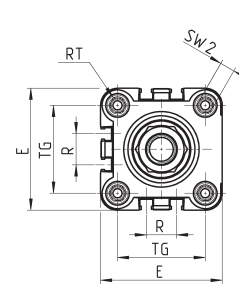
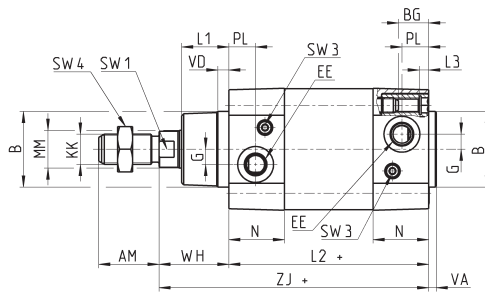

Ø32-40-50-63-125



Ø80-100

+ = sumar la carrera

Nota tabla:  
\* = llave especial 80-62/8C  
(ver accesorios)

CILINDROS SERIE 61

DIMENSIONES																									
Ø	AM	B	BG	E	EE	G	KK	L1	L2+	L3	MM	N	PL	R	RT	SW1	SW2	SW3	SW4	TG	VA	VD	WH	ZJ+	Carrera de amortig. delantera/trasera
32	22	30	16	46	G1/8	5	M10x1,25	18	94	5	12	26	14	13	M6	10	6	2	17	32,5	4	5	26	120	17 / 12
40	24	35	16	55	G1/4	5	M12x1,25	21	105	5	16	29	15	13,5	M6	13	6	2	19	38	4	5	30	135	20 / 17
50	32	40	16	64,5	G1/4	8	M16x1,5	25	106	5	20	29,5	15	16	M8	17	8	3	24	46,5	4	6	37	143	15 / 14
63	32	45	16	75	G3/8	8	M16x1,5	26	121	5	20	36,5	21	28	M8	17	8	3	24	56,5	4	6	37	158	17 / 16
80	40	45	19	93	G3/8	8	M20x1,5	30	128	0	25	36	21	30	M10	22	*	5	30	72	4	7	46	174	20 / 20
100	40	55	19,5	110	G1/2	8	M20x1,5	35	138	0	25	38,5	23	40	M10	22	*	5	30	89	4	7	51	189	21 / 19
125	54	60	23	135	G1/2	10,5	M27x2	42	160	0	32	43	23,5	50	M12	27	12	4	41	110	6	8	65	225	26 / 25

### Cilindros Serie 61 - vástago pasante

NOTA: en la versión simple efecto las cuotas ZM y L2 se incrementarán de 25 mm.

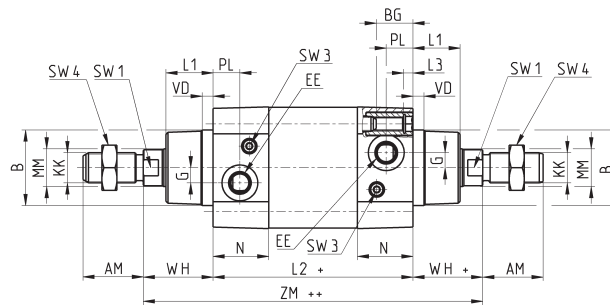

Ø32-40-50-63-125



Ø80-100

+ = sumar la carrera

++ = sumar la carrera dos veces

Nota tabla:  
\* = llave especial 80-62/8C  
(ver accesorios)

DIMENSIONES																								
Ø	AM	B	BG	E	EE	G	KK	L1	L2+	L3	MM	N	PL	R	RT	SW1	SW2	SW3	SW4	TG	VD	WH	ZM++	Carrera de amortiguación
32	22	30	16	46	G1/8	5	M10x1.25	18	94	5	12	26	14	13	M6	10	6	2	17	32.5	5	26	146	17
40	24	35	16	55	G1/4	5	M12x1.25	21	105	5	16	29	15	13.5	M6	13	6	2	19	38	5	30	165	20
50	32	40	16	64.5	G1/4	8	M16x1.5	25	106	5	20	29.5	15	16	M8	17	8	3	24	46.5	6	37	180	15
63	32	45	16	75	G3/8	8	M16x1.5	26	121	5	20	36.5	21	28	M8	17	8	3	24	56.5	6	37	195	17
80	40	45	19	93	G3/8	8	M20x1.5	30	128	0	25	36	21	30	M10	22	*	5	30	72	7	46	220	20
100	40	55	19.5	110	G1/2	8	M20x1.5	35	138	0	25	38.5	23	40	M10	22	*	5	30	89	7	51	240	21
125	54	60	23	135	G1/2	10.5	M27x2	42	160	0	32	43	23.5	50	M12	27	12	4	41	110	8	65	290	26

### Cilindros Serie 61 - Versión tandem



+ = sumar la carrera  
 ++ = sumar la carrera dos veces  
 1 = Salida del cilindro  
 2 = Retorno del cilindro

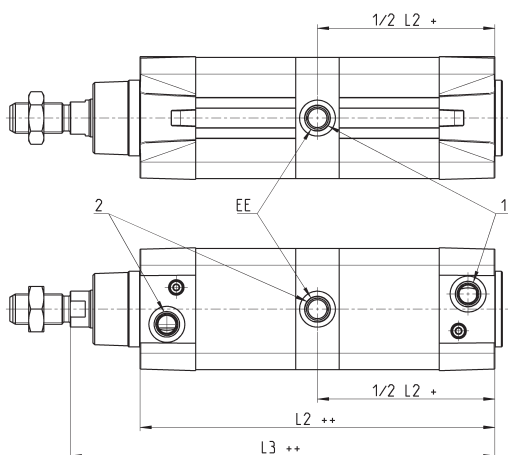

DIMENSIONES			
∅	EE	L2+	L3+
32	G1/8	172,5	197,5
40	G1/4	191,5	221,5
50	G1/4	188	225
63	G3/8	204	241
80	G3/8	225,5	271,5
100	G1/2	231	282
125	G1/2	264	329

### Cilindros Serie 61 - Versión con bloqueo vástago



+ = sumar la carrera

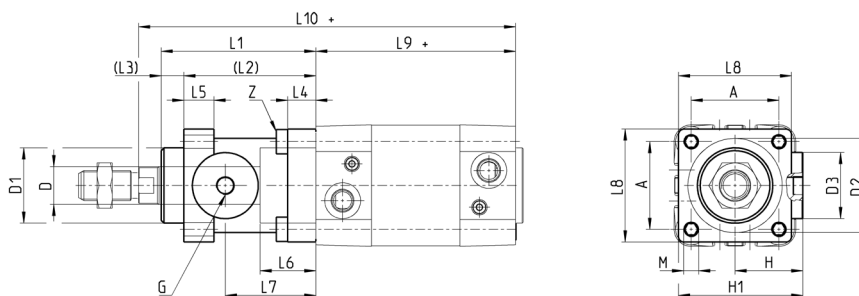

DIMENSIONES																				
∅	∅D	∅D1	∅D2	∅D3	A	G	H	H1	L1	L2	L3	L4	L5	L6	L7	L8	L9+	L10+	M	Z
32	12	30.5	35	25	32,5	M5	25,5	46,5	58	48	10	8	13	20,5	34	45	94	160	M6	M6x20
40	16	35	40	28	38	G1/8	30	53	65	55	10	8	13	22,5	38	50	105	178	M6	M6x20
50	20	40	50	35	46,5	G1/8	36	64	82	70	12	15	16	29,5	48	60	106	200	M8	M6x20
63	20	45	60	38	56,5	G1/8	40	75	82	70	12	15	16	29,5	49,5	70	121	215	M8	M8x30
80	25	45	80	48	72	G1/8	50	95	110	90	20	18	20	35	61	90	128	254	M10	M10x35
100	25	55	100	58	89	G1/8	58	110,5	115	100	15	18	20	39	69	105	138	269	M10	M10x35
125	32	60	130	65	110	G1/8	80	150	167	122	45	22	30	51	86,5	140	160	350	M12	M12x40

### Amarre con patas Mod. B

Material: acero zincado.



El suministro incluye:  
Nº 2 patas  
Nº 4 tornillos  
+ = sumar la carrera

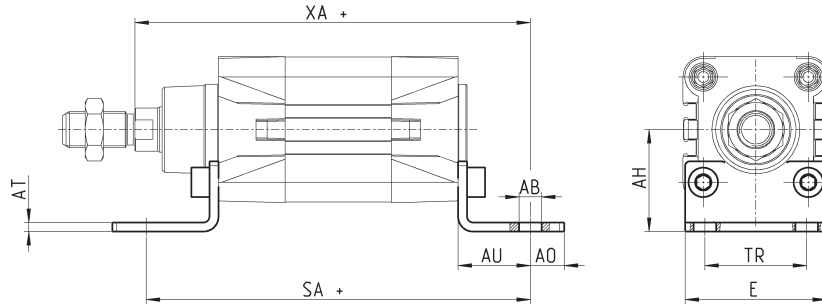

Mod.	∅	AT	SA+	XA+	TR	E	AB	AH	AO	AU	fuerza de torque
B-41-32	32	4	142	144	32	45	7	32	11	24	5 Nm
B-41-40	40	4	161	163	36	53,5	10	36	15	28	5 Nm
B-41-50	50	4	170	175	45	62,5	10	45	15	32	10 Nm
B-41-63	63	5	185	190	50	73	10	50	15	32	10 Nm
B-41-80	80	6	210	216	63	92	12	63	20	41	15 Nm
B-41-100	100	6	220	230	75	108,5	14,5	71	25	41	15 Nm
B-41-125	125	7	250	270	90	132	16,5	90	25	45	20 Nm

### Amarre con brida ant. y post. Mod. D-E

Material: aluminio.

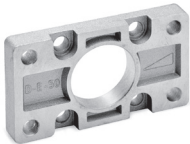

El suministro incluye:  
Nº 1 brida  
Nº 4 tornillos  
+ = sumar la carrera

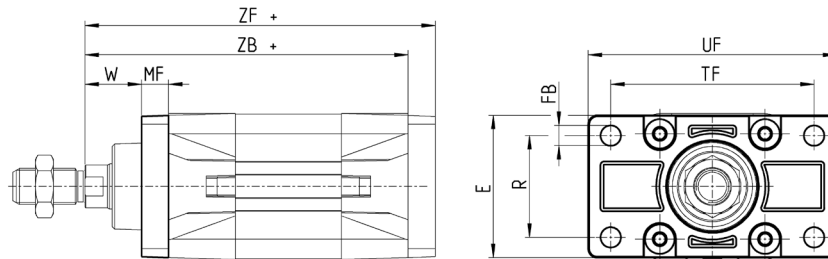

Mod.	∅	W	MF	ZB+	TF	R	UF	E	FB	ZF+	fuerza de torque
D-E-41-32	32	16	10	120	64	32	86	45	7	130	5 Nm
D-E-41-40	40	20	10	135	72	36	88	52	9	145	5 Nm
D-E-41-50	50	25	12	143	90	45	110	63	9	155	10 Nm
D-E-41-63	63	25	12	158	100	50	116	73	9	170	10 Nm
D-E-41-80	80	30	16	174	126	63	148	95	12	190	15 Nm
D-E-41-100	100	35	16	189	150	75	176	115	14	205	15 Nm
D-E-41-125	125	45	20	225	180	90	224	135	16	245	20 Nm

### Amarre con charnela hembra post. Mod. C y C-H

Material: aluminio.

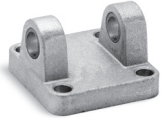

El suministro incluye:  
Nº 1 charnela hembra  
Nº 4 tornillos

+ = sumar la carrera

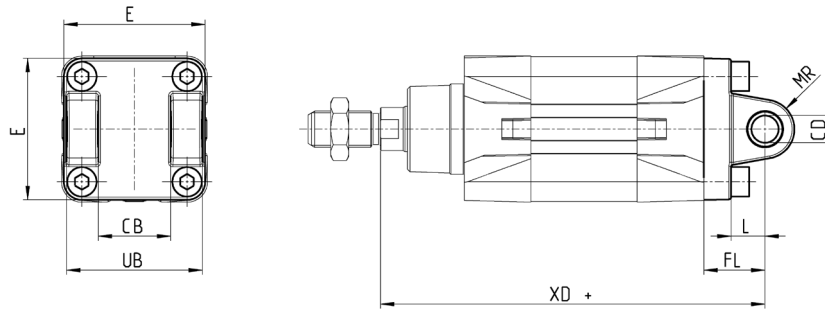

Mod.	∅	CD	L	FL	XD+	MR	E	CB	UB	fuerza de torque
C-41-32	32	10	12	22	142	10	45	26	45	5 Nm
C-41-40	40	12	15	25	160	12	53.5	28	52	5 Nm
C-41-50	50	12	15	27	170	13	62.5	32	60	10 Nm
C-H-41-63	63	16	20	32	190	17	73	40	70	10 Nm
C-H-41-80	80	16	24	36	210	17	92	50	90	15 Nm
C-H-41-100	100	20	29	41	230	21	108.5	60	110	15 Nm
C-H-41-125	125	25	30	50	275	26	132	70	130	20 Nm

### Amarre con charnela hembra ant. Mod. H y C-H

Material: aluminio.

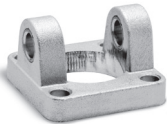

El suministro incluye:  
Nº 1 charnela hembra  
Nº 4 tornillos

+ = sumar la carrera

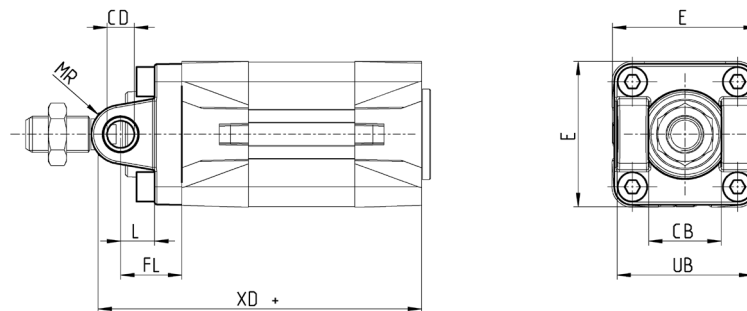

Mod.	∅	CB	UB	E	XD	FL	L	CD	MR	fuerza de torque
H-41-32	32	26	45	45	120	22	12	10	10	5 Nm
H-41-40	40	28	52	53.5	135	25	15	12	12	5 Nm
H-41-50	50	32	60	62.5	143	27	15	12	13	10 Nm
H-60-63	63	40	70	73	158	32	20	16	17	10 Nm
C-H-41-80	80	50	90	92	174	36	24	16	17	15 Nm
C-H-41-100	100	60	110	108.5	189	41	29	20	21	15 Nm
C-H-41-125	125	70	130	132	225	50	30	25	26	20 Nm



### Amarre con charnela macho post. Mod. L

Material: aluminio.

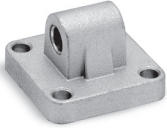

El suministro incluye:  
N° 1 charnela macho  
N° 4 tornillos

+ = sumar la carrera

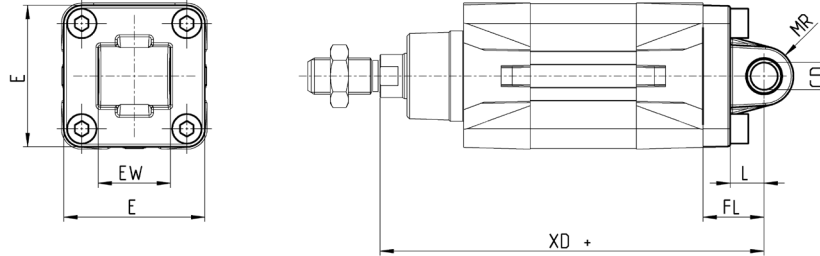

DIMENSIONES									
Mod.	∅	CD	L	FL	XD+	MR	E	EW	fuerza de torque
L-41-32	32	10	12	22	142	10	45	26	5 Nm
L-41-40	40	12	15	25	160	13	53.5	28	5 Nm
L-41-50	50	12	15	27	170	13	62.5	32	10 Nm
L-41-63	63	16	20	32	190	17	73	40	10 Nm
L-41-80	80	16	24	36	210	17	92	50	15 Nm
L-41-100	100	20	29	41	230	21	108.5	60	15 Nm
L-41-125	125	25	30	50	275	26	132	70	20 Nm

### Amarre con charnela intermedia Mod. F

Material: acero zincado.



El suministro incluye:  
N° 1 charnela intermedia  
N° 4 prisioneros  
N° 4 elementos de fijación

+ = sumar la carrera

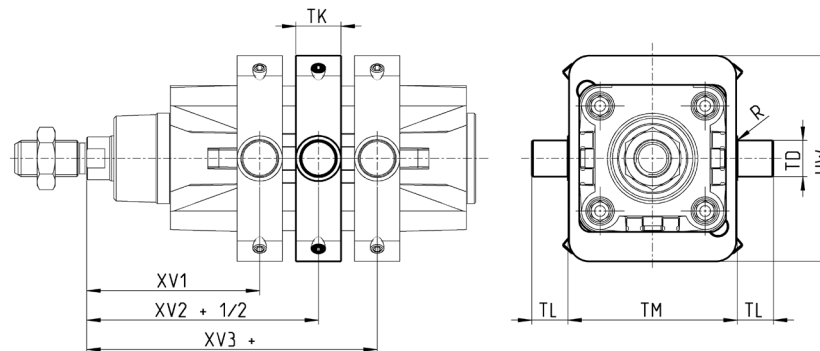

DIMENSIONES										
Mod.	∅	XV1	XV2	XV3	TM	TK	TD	TL	UW	R
F-61-32	32	61	73	85	50	18	12	12	65	0,1
F-61-40	40	69	82,5	96	63	20	16	16	75	0,15
F-61-50	50	76,5	90	103,5	75	20	16	16	91	0,15
F-61-63	63	86	97,5	109	90	25	20	20	94	0,15
F-61-80	80	94,5	110	125,5	110	25	20	20	130	0,15
F-61-100	100	104,5	120	135,5	132	30	25	25	145	0,2
F-61-125	125	123	145	167	160	30	25	25	155	0,2

### Combinación de accesorios Mod. C+L+S

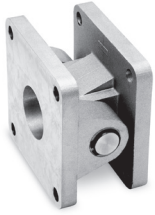

Material: aluminio.

+ = sumar la carrera

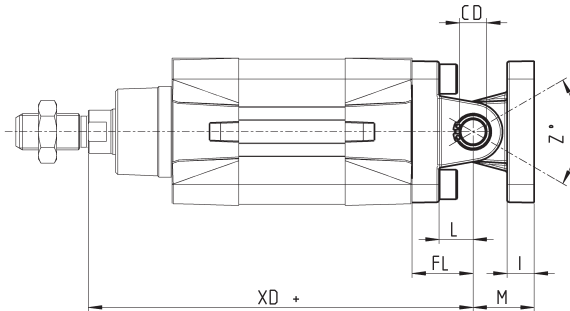
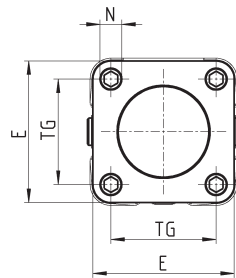

DIMENSIONES												
Mod.	∅	E	TG	$\varnothing$ N	XD+	$\varnothing$ CD	L	FL	I	M	Z° (max)	Fuerza de priete
C+L+S	32	45	32.5	6.5	142	10	12	22	10	22	30	5 Nm
C+L+S	40	53.5	38	6.5	160	12	15	25	10	25	40	5 Nm
C+L+S	50	62.5	46.5	9	170	12	15	27	12	27	25	10 Nm
C+L+S	63	73	56.5	9	190	16	20	32	12	32	36	10 Nm
C+L+S	80	92	72	11	210	16	24	36	12	36	34	15 Nm
C+L+S	100	108.5	89	11	230	20	29	41	12	41	38	15 Nm
C+L+S	125	132	110	13	275	25	30	50	25	50	30	20 Nm

### Soporte 90° para basculante hembra Mod. ZC

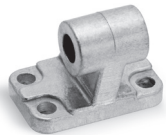

CETOP RP 107P.  
Material: aluminio.

El suministro incluye:  
N° 1 soporte macho

+ = sumar la carrera

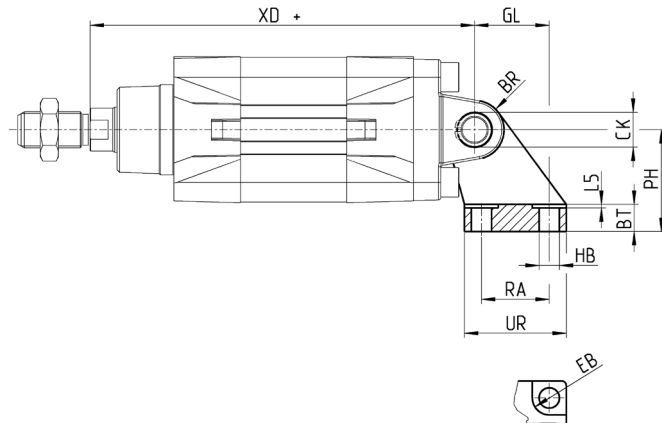
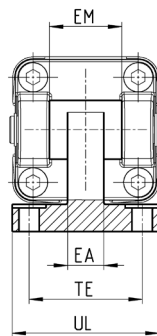

DIMENSIONES																
Mod.	∅	EB	CK	HB	XD+	TE	UL	EA	GL	L5	RA	EM	UR	PH	BT	BR
ZC-32	32	11	10	6,6	142	38	51	10	21	1,6	18	26	31	32	8	10
ZC-40	40	11	12	6,6	160	41	54	15	24	1,6	22	28	35	36	10	11
ZC-50	50	15	12	9	170	50	65	16	33	1,6	30	32	45	45	12	13
ZC-63	63	15	16	9	190	52	67	16	37	1,6	35	40	50	50	14	15
ZC-80	80	18	16	11	210	66	86	20	47	2,5	40	50	60	63	14	15
ZC-100	100	18	20	11	230	76	96	20	55	2,5	50	60	70	71	17	19
ZC-125	125	20	25	14	275	94	124	30	70	3,2	60	70	90	90	20	22,5

**Amarre con charnela y rótula Mod. R\***

\* Amarre no según normas ISO 15552.  
Material: aluminio.

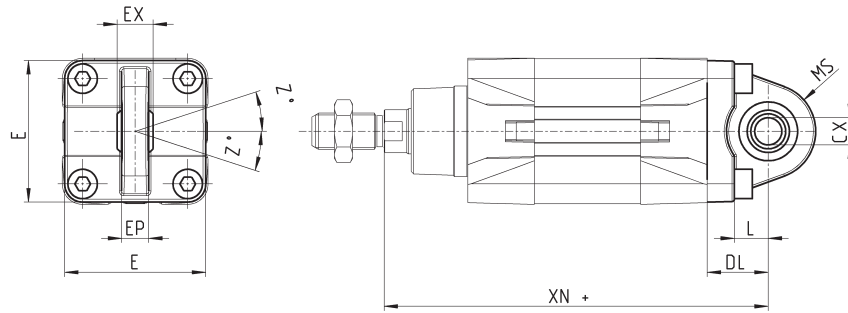
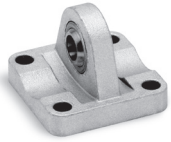

El suministro incluye:  
Nº 1 charnela suelta  
Nº 4 tornillos

+ = sumar la carrera

CILINDROS SERIE 61

Mod.	∅	∅CX	L	DL	XN+	MS	E	EX	EP	Z	fuerza de torque
R-41-32	32	10	12	22	142	18	45	14	10.5	4	5 Nm
R-41-40	40	12	15	25	160	18	53.5	16	12	4	5 Nm
R-41-50	50	12 *	15	27	170	21	62.5	16 *	12 *	4	10 Nm
R-41-63	63	16	20	32	190	23	73	21	15	4	10 Nm
R-41-80	80	16 *	24	36	210	28	92	21 *	15 *	4	15 Nm
R-41-100	100	20	29	41	230	30	108.5	25	18	4	15 Nm
R-41-125	125	30	30	50	275	40	140	37	25	4	20 Nm

**Soporte para charnela int. Mod. BF**

Material: aluminio.

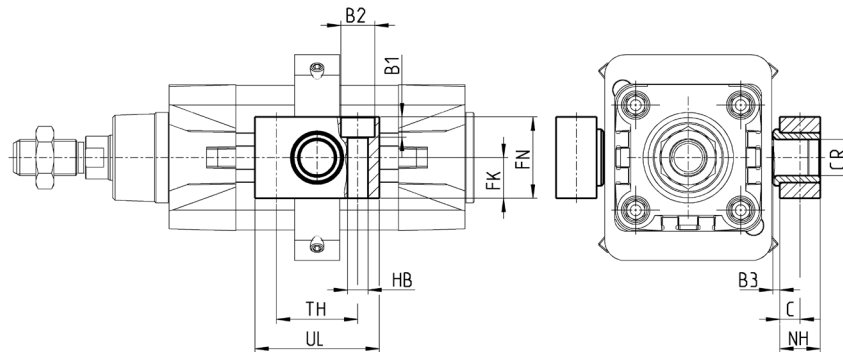

El suministro incluye:  
Nº 2 soportes

Mod.	∅	∅CR	NH	C	B3	TH	UL	FK	FN	B1	B2	HB
BF-32	32	12	15	7,5	3	32	46	15	30	6,8	11	6,6
BF-40-50	40 - 50	16	18	9	3	36	55	18	36	9	15	9
BF-63-80	63 - 80	20	20	10	3	42	65	20	40	11	18	11
BF-100-125	100 - 125	25	25	12,5	3,5	50	75	25	50	13	20	14

## Accesorio para conectar las válvulas en el cilindro

Las placas de conexión Mod. PCV permiten conectar válvulas o electroválvulas directamente en el cilindro, formando una unidad compacta.

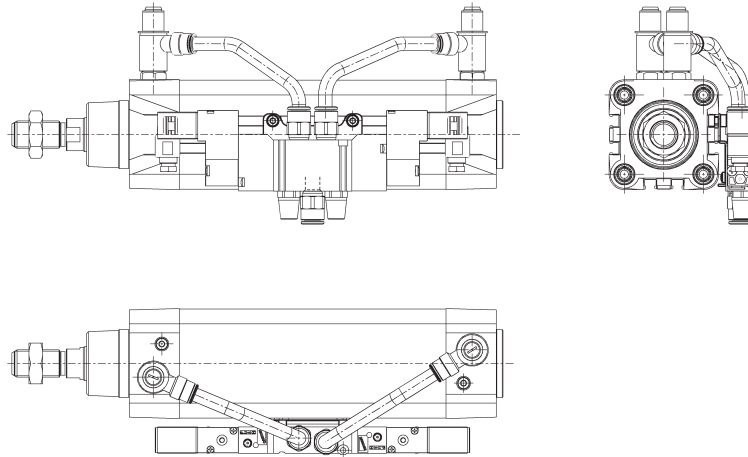

DIMENSIONES	
Mod.	
PCV-61-K3	para fijar válvulas - electroválvulas Serie 3
PCV-61-K4	para fijar válvulas - electroválvulas Serie 4 conexión G1/4
PCV-62-KEN	para fijar válvulas - electroválvulas Serie EN
PCV-61-K8	para fijar válvulas - electroválvulas Serie 4 conexión G1/8 y Serie 3 conexión G1/4

## Perno Mod. S



El suministro incluye:  
N° 1 perno (acero inox 303)  
N° 2 Seeger (acero)

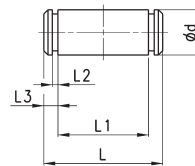

DIMENSIONES							
Mod.	Ø	d	L	L1	L2	L3	
S-32	32	10	52	46	1,1	3	
S-40	40	12	59	53	1,1	3	
S-50	50	12	67	61	1,1	3	
S-63	63	16	77	71	1,1	3	
S-80	80	16	97	91	1,1	3	
S-100	100	20	121	111	1,3	5	
S-125	125	25	140,5	132	1,3	4,25	

### Horquilla esférica para vástago Mod. GA



ISO 8139.  
Material: acero zincado.

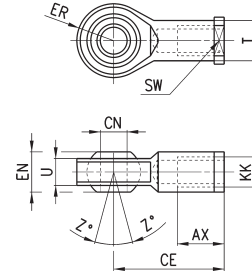

Mod.	$\varnothing_{CN}^{(H7)}$	U	EN	ER	AX	CE	KK	$\varnothing_T$	Z	SW
GA-32	10	10,5	14	14	20	43	M10X1,25	15	6,5	17
GA-40	12	12	16	16	22	50	M12X1,25	17,5	6,5	19
GA-50-63	16	15	21	21	28	64	M16X1,5	22	7,5	22
GA-80-100	20	18	25	25	33	77	M20x1,5	27,5	7	30
GA-41-125	30	25	37	37	51	110	M27x2	40	7,5	41

### Horquilla con rótula para vástago Mod. GY



Material: zama y acero zincado.

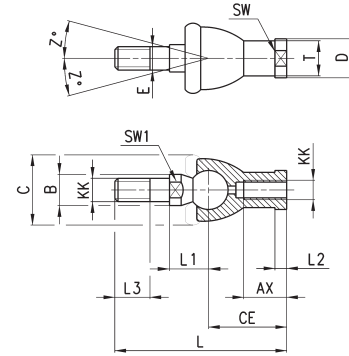

DIMENSIONES																
Mod.	$\varnothing$	KK	L	CE	L2	AX	SW	SW1	L1	L3	$\varnothing_T$	$\varnothing_D$	E	$\varnothing_B$	C	Z
GY-32	32	M10X1,25	74	35	6,5	18	17	11	19,5	15	15	19	10	14	28	15
GY-40	40	M12X1,25	84	40	6,5	20	19	17	21	17	17,5	22	12	19	32	15
GY-50-63	50-63	M16X1,5	112	50	8	27	22	19	27,5	23	22	27	16	22	40	11
GY-80-100	80-100	M20x1,5	133	63	10	38	30	24	31,5	25	27,5	34	20	27	45	7,5

### Horquilla para vástago Mod. G

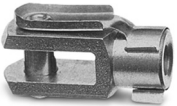

ISO 8140.  
Material: acero zincado.

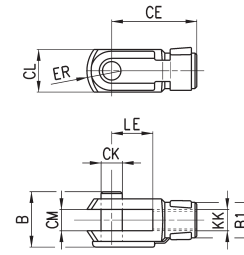

Mod.	$\varnothing_{CK}$	LE	CM	CL	ER	CE	KK	B	$\varnothing_{B1}$
G-25-32	10	20	10	20	12	40	M10 X 1,25	26	18
G-40	12	24	12	24	14	48	M12 X 1,25	32	20
G-50-63	16	32	16	32	19	64	M16 X 1,5	40	26
G-80-100	20	40	20	40	25	80	M20 X 1,5	48	34
G-41-125	30	54	30	55	38	110	M27 X 2	74	48

### Tuerca para vástago Mod. U



ISO 4035.  
Material: acero zincado.

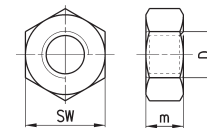

DIMENSIONES			
Mod.	D	m	SW
U-25-32	M10X1,25	6	17
U-40	M12X1,25	7	19
U-50-63	M16X1,5	8	24
U-80-100	M20x1,5	9	30
U-41-125	M27x2	12	41

### Accesorio autoalineable Mod. GK

Material: acero zincado.

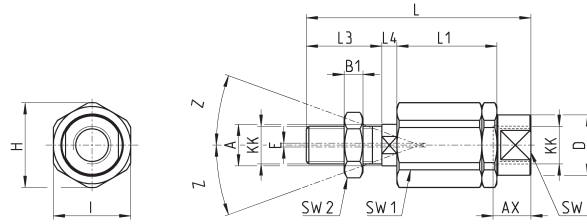

DIMENSIONES																	
Mod.	∅	KK	L	L1	L3	L4	$g_A$	$g_D$	H	I	SW	SW1	SW2	B1	AX	Z	E
GK-25-32	25-32	M10x1,25	71,5	35	20	7,5	14	22	32	30	19	12	17	5	22	4	2
GK-40	40	M12x1,25	75,5	35	24	7,5	14	22	32	30	19	12	19	6	22	4	2
GK-50-63	50-63	M16x1,5	104	53	32	10	22	32	45	41	27	20	24	8	30	3	2
GK-80-100	80-100	M20x1,5	119	53	40	10	22	32	45	41	27	20	30	10	37	3	2
GK-125	125	M27x2	147	60	54	10	32	57	70	65	54	24	41	12	48	4	2

### Conjunto compensador Mod. GKF

Material: acero zincado.

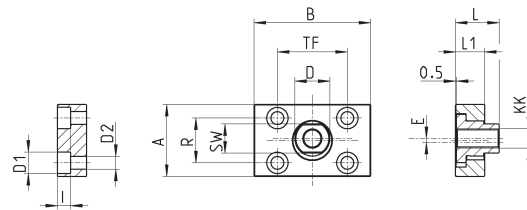

DIMENSIONES														
Mod.	∅	KK	A	B	R	TF	L	L1	I	∅ D	∅ D1	∅ D2	SW	E
GKF-25-32	32	M10x1,25	37	60	23	36	22,5	15	6,8	18	11	6,6	15	2
GKF-40	40	M12x1,25	56	60	38	42	22,5	15	9	20	15	9	15	2,5
GKF-50-63	50-63	M16x1,5	80	80	58	58	26,5	15	10,5	25	18	11	22	2,5
GKF-80-100	80-100	M20x1,5	90	90	65	65	32,5	20	13	30,5	20	14	27	2,5
GKF-125	125	M27x2	90	90	65	65	35,5	20	13	40	20	14	36	4

### Llave especial para el desmontaje de cilindros ∅ 80 y 100

Material: acero templado

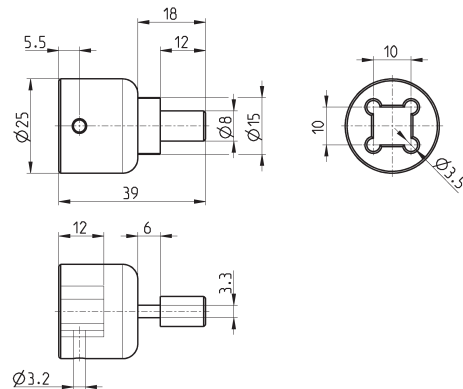

Mod.
80-62/8C