

# Electromechanical cylinders Series 6E

Sizes 32, 40, 50, 63, 80, 100

SERIES 6E ELECTROMECHANICAL CYLINDERS

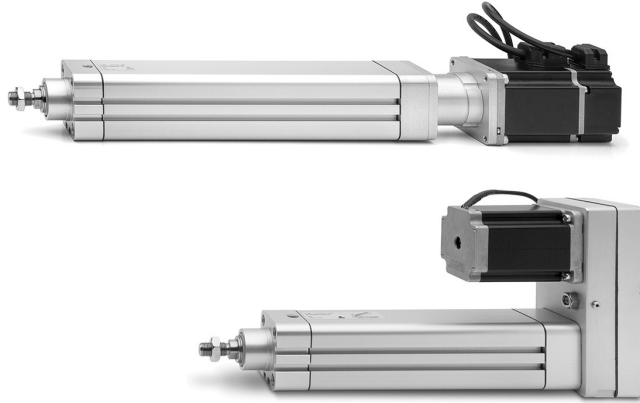

The Series 6E cylinders are mechanical linear actuators with rod, in which the rotary movement, generated by a motor, is converted into a linear movement by means of a recirculating ball screw. Available in 6 sizes, the Series 6E has dimensions based on the ISO 15552 standard and it is therefore possible to use the mounting accessories of the pneumatic cylinders.

The cylinders are equipped with a magnet that makes it possible to use external magnetic proximity switches (Series CST, CSG), allowing operations like homing or extra-stroke readings to be performed. The Series 6E is equipped with specific interface kits, which make it possible to connect the motor, both in line and parallel. High precision and easy mounting make the Series 6E the ideal solution for different applications, especially for multi-position systems.

- » In compliance with the ISO 15552 standard
- » Multi-position system with transmission of the movement by means of a recirculating ball screw
- » Possibility to connect the motor in line or parallel
- » Large range of motor interfaces
- » Permanent pre-lubrication (maintenance free)
- » High positioning repeatability
- » Reduced axial backlash
- » Possibility to use magnetic sensors
- » Integrated anti-rotation system of the rod
- » IP65
- » Wide range of fixing accessories

## GENERAL DATA

<b>Construction</b>	electromechanical cylinder with recirculating ball screw
<b>Design</b>	profile with thread rolling screws based on the ISO 15552 standard
<b>Operation</b>	multi-position actuator with high precision linear movement
<b>Sizes</b>	32, 40, 50, 63, 80, 100
<b>Anti-rotation function</b>	with anti-friction pads in technopolymer
<b>Mounting</b>	front / rear flange, with feet, with front / rear / swivel trunnion
<b>Mounting motor</b>	in line and parallel
<b>Operating temperature</b>	0°C ÷ 50°C
<b>Storage temperature</b>	-20°C ÷ 80°C
<b>Protection class</b>	IP65
<b>Lubrication</b>	Not necessary. A pre-lubrication is performed on the cylinder.
<b>Max. Reversing backlash</b>	0,02 mm
<b>Repeatability</b>	± 0,02
<b>Duty cycle</b>	100%
<b>Max rotation play</b>	± 0,4°
<b>Use with external sensors</b>	slots on three sides for sensors model CST and CSG

**CODING EXAMPLE**

<b>6E</b>	<b>032</b>	<b>BS</b>	<b>0200</b>	<b>P05</b>	<b>A</b>	<b>P</b>
<b>6E</b>	SERIES					
<b>032</b>	SIZE 032 = 32 040 = 40 050 = 50		063 = 63 080 = 80 100 = 100			
<b>BS</b>	DESIGN BS = recirculating ball screw					
<b>0200</b>	STROKE 100 ÷ 1500 mm					
<b>P05</b>	SCREW PITCH P05 = 5 mm P10 = 10 mm P16 = 16 mm (for size 40 only) P20 = 20 mm (for size 50,80,100 only)		P25 = 25 mm (for size 63 only) P32 = 32 mm (for size 80 only) P40 = 40 mm (for size 100 only)			
<b>A</b>	CONSTRUCTION A = standard with rod nut					
<b>P</b>	VERSION P = IP65 ( _ _ _ ) = extended piston rod _ _ _ mm					

SERIES 6E ELECTROMECHANICAL CYLINDERS

**MECHANICAL CHARACTERISTICS**

MECHANICAL CHARACTERISTICS																				
		Size 32	Size 32	Size 40	Size 40	Size 40	Size 50	Size 50	Size 50	Size 63	Size 63	Size 63	Size 80	Size 80	Size 80	Size 80	Size 100	Size 100	Size 100	Size 100
<b>BS screw pitch "P"</b>	[mm]	5	10	5	10	16	5	10	20	5	10	25	5	10	20	32	5	10	20	40
<b>Dynamic load coefficient "C"</b>	[N]	6600	4400	12000	8500	9150	14900	11300	7800	17700	20500	11300	26300	52500	28200	26100	35100	55900	45300	55900
<b>Average load <sup>(A)</sup></b>	[N]	525	440	950	850	1070	1180	1130	980	1405	2050	1535	2085	5250	3550	3845	2785	5590	5705	8875
<b>Maximum force <sup>(B)</sup></b>	[N]	1075	1075	3360	3360	3360	5440	5440	5130	8400	8400	6187	12600	12600	12600	12600	18000	18000	18000	18000
<b>Max applicable torque to screw's shaft</b>	[Nm]	0,95	1,90	2,97	5,94	9,51	4,81	9,62	18,14	7,43	14,85	27,35	11,14	22,28	44,56	71,30	15,92	31,83	63,66	127,32
<b>Max linear cylinder's speed <sup>(B)</sup></b>	[m/s]	0,56	1,12	0,42	0,84	1,33	0,33	0,67	1,33	0,27	0,53	1,33	0,23	0,47	0,94	1,5	0,19	0,38	0,75	1,05
<b>Max rotational cylinder's speed</b>	[rpm]	6670	6670	5000	5000	5000	4000	4000	4000	3200	3200	3200	2810	2810	2810	2810	2250	2250	2250	2250
<b>Max cylinder's acceleration</b>	[m/s <sup>2</sup> ]	25	25	25	25	25	25	25	25	25	25	25	25	25	25	25	25	25	25	25
<b>Minimum stroke</b>	[mm]	15	25	15	25	40	15	25	50	15	25	65	15	25	50	80	15	25	50	100
<b>Maximum stroke</b>	[mm]	500	500	700	700	700	1000	1000	1000	1200	1200	1200	1500	1500	1500	1500	1500	1500	1500	1500
<b>Mass of actuator, stroke zero</b>	[kg]	1,18	1,18	1,40	1,40	1,40	2,28	2,28	2,28	3,5	3,5	3,5	6,44	6,44	6,44	6,44	10,73	10,73	10,73	10,73
<b>Mass of actuator, variable with stroke</b>	[kg/mm]	3,77E-03	3,77E-03	5,30E-03	5,30E-03	5,30E-03	6,30E-03	6,30E-03	6,30E-03	9,77E-03	9,77E-03	9,77E-03	1,37E-02	1,37E-02	1,37E-02	1,37E-02	2,05E-02	2,05E-02	2,05E-02	2,05E-02
MOVING MASSES AND INERTIA																				
		Size 32	Size 32	Size 40	Size 40	Size 40	Size 50	Size 50	Size 50	Size 63	Size 63	Size 63	Size 80	Size 80	Size 80	Size 80	Size 100	Size 100	Size 100	Size 100
<b>Inertia, stroke zero "J<sub>s</sub>"</b>	[kg·cm <sup>2</sup> ]	0,029	0,029	0,079	0,079	0,079	0,218	0,218	0,218	0,664	0,664	0,664	2,309	2,309	2,309	2,309	5,265	5,265	5,265	5,265
<b>Inertia, variable with stroke "K<sub>v</sub>"</b>	[kg·cm <sup>2</sup> /mm]	2,00E-04	2,00E-04	5,00E-04	5,00E-04	5,00E-04	1,20E-03	1,20E-03	1,20E-03	3,00E-03	3,00E-03	3,00E-03	8,10E-03	8,10E-03	8,10E-03	8,10E-03	1,98E-02	1,98E-02	1,98E-02	1,98E-02
<b>Sliding mass, stroke zero "m<sub>ct</sub>"</b>	[kg]	0,15	0,15	0,43	0,43	0,43	0,70	0,70	0,70	1,07	1,07	1,07	2,25	2,25	2,25	2,25	3,94	3,94	3,94	3,94
<b>Sliding mass, variable with stroke "K<sub>v</sub>"</b>	[kg/mm]	7,90E-04	7,90E-04	9,88E-04	9,88E-04	9,88E-04	1,14E-03	1,14E-03	1,14E-03	1,38E-03	1,38E-03	1,38E-03	1,88E-03	1,88E-03	1,88E-03	1,88E-03	2,37E-03	2,37E-03	2,37E-03	2,37E-03

<sup>(A)</sup> Value refers to a covered distance of 10000 Km (see the diagrams "Life of the cylinder according to the average axial force applied").

<sup>(B)</sup> The maximum speed and the maximum force of cylinder change according to its stroke (see the diagrams "maximum speed of cylinder according to its stroke" and "maximum force of cylinder according to its stroke").

**SERIES 6E MATERIALS**

SERIES 6E ELECTROMECHANICAL CYLINDERS

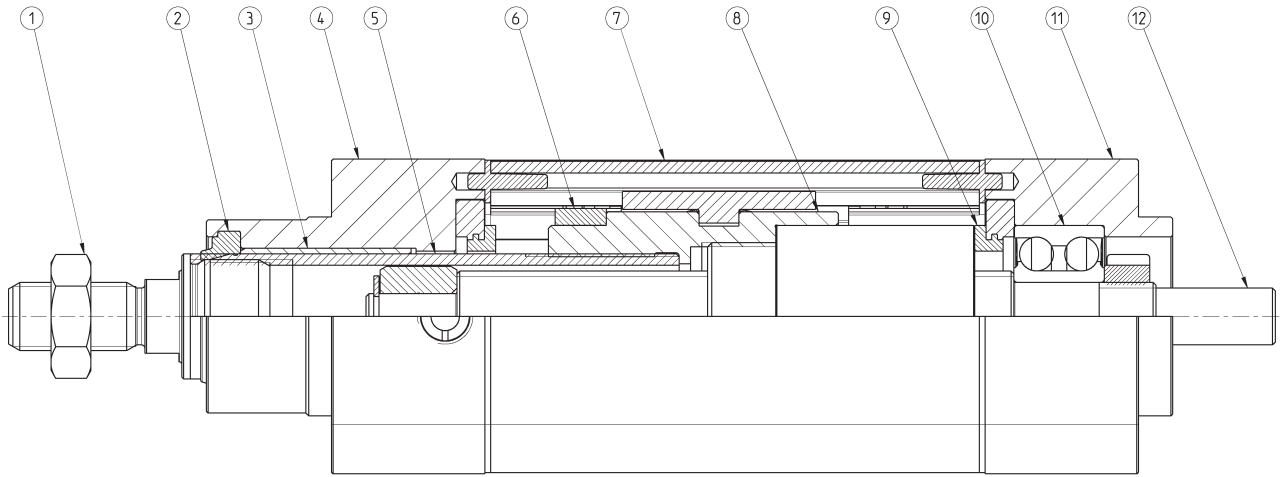

LIST OF COMPONENTS	
PARTS	MATERIALS
1. Rod nut	Zinc-plated steel
2. Rod seal	PU
3. Bushing	Technopolymer
4. Front endcap	Anodized aluminium alloy
5. Rod	Stainless steel
6. Magnet	Plastoferrite
7. Extrusion profile	Anodized aluminium alloy
8. Guiding element BS screw	Aluminium alloy
9. End stroke seals	NBR
10. Bearing	Steel
11. Rear endcap	Anodized aluminium alloy
12. BS ball screw	Steel

## ACCESSORIES FOR SERIES 6E CYLINDERS



Piston rod socket joint  
Mod. GY



Piston rod lock nut  
Mod. U



Clevis pin Mod. S

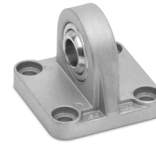

Rear trunnion ball-joint  
Mod. R

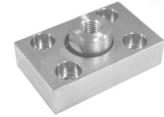

Coupling piece  
Mod. GKF



Swivel ball joint Mod. GA



90° male trunnion  
Mod. ZC

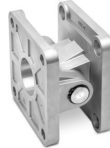

Swivel Combination  
Mod. C+L+S

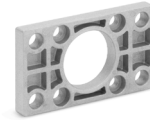

Front flange  
Mod. D-E



Self aligning rod  
Mod. GK



Foot mount Mod. B-6E



Rear female trunnion  
Mod. C and C-H

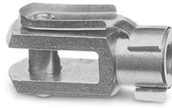

Rod fork end Mod. G



Rear trunnion male  
Mod. L



Side clamping bracket  
Mod. BG

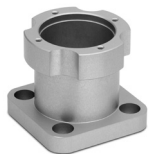

Housing for axial  
connection Mod. CM

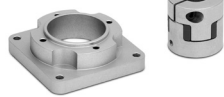

Flange for axial  
connection Mod. FM



Kit for axial connection  
Mod. AM



Kit for parallel connection  
Mod. PM

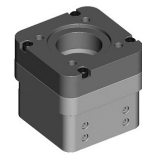

Kit for axial connection  
Mod. AR

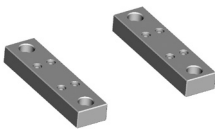

Cylinder bracket  
Mod. BA-6E

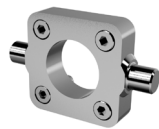

Front spot faced trunnion  
Mod. FN



Counter bracket for  
trunnion Mod. BF



Anti-rotation guide units



Nuts for slots

All accessories are supplied separately, except for piston rod lock nut Mod. U

## HOW TO CALCULATE THE LIFE OF THE CYLINDER

To perform a correct dimensioning of the Series 6E cylinder, you need to consider some facts.

Among these, the most important are:

- Dynamics of the system
- Operation and pause cyclicity
- Work environment
- General performance requirements: repeatability, accuracy, precision, etc.

### CALCULATE THE LIFE IN ROTATIONS

where:

$L_r$  = Life of the cylinder in number of rotations of the BS ball screw

$C$  = Dynamic load coefficient of the cylinder [N]

$F_m$  = Average axial force applied [N]

$f_w$  = Safety coefficient according to the working conditions

$$L_r = \left( \frac{C}{F_m \cdot f_w} \right)^3 \cdot 10^6$$

### CALCULATION OF LIFE IN km

where:

$L_{km}$  = Life of the cylinder in km [km]

$p$  = pitch of the BS ball screw [mm]

$$L_{km} = \frac{L_r \cdot p}{10^6}$$

### CALCULATION OF THE LIFE IN HOURS

where:

$L_h$  = Life of the cylinder in hours

$n_m$  = average number of revolutions of the RDS ball screw [rpm]

$$L_h = \frac{L_r}{n_m \cdot 60}$$

APPLICATION	ACCELERATION [ m/s <sup>2</sup> ]	SPEED [ m/s ]	DUTY CYCLE	$f_w$ COEFFICIENT
light	< 5,0	< 0,5	< 35%	1,0 ÷ 1,25
normal	5,0 ÷ 15,0	0,5 ÷ 1,0	35% ÷ 65%	1,25 ÷ 1,5
heavy	> 15,0	> 1,0	> 65%	1,5 ÷ 3,0

## ANALYSIS OF THE DUTY CYCLE AND OF SYSTEM PAUSES

The analysis of the duty cycle and of the pauses of the system is essential to calculate the average  $F_m$  axial loads and the number of average revolutions  $n_m$  that act on the cylinder. Normally, the duty cycle is composed by phases and for each single phase, we can have an acceleration, constant speed or deceleration.

$F_m$  = CALCULATION OF THE AVERAGE AXIAL FORCE

$n_m$  = CALCULATION OF THE AVERAGE NUMBER OF REVOLUTIONS

The table shown below reports the values of acceleration, speed and deceleration for each phase.

$$F_m = \sqrt[3]{\frac{(F_{a1}^3 \cdot n_{a1} \cdot t_{a1}) + (F_{vc1}^3 \cdot n_{vc1} \cdot t_{vc1}) + (F_{d1}^3 \cdot n_{d1} \cdot t_{d1}) + \dots + (F_{an}^3 \cdot n_{an} \cdot t_{an}) + (F_{vcn}^3 \cdot n_{vcn} \cdot t_{vcn}) + (F_{dn}^3 \cdot n_{dn} \cdot t_{dn})}{(n_{a1} \cdot t_{a1}) + (n_{vc1} \cdot t_{vc1}) + (n_{d1} \cdot t_{d1}) + \dots + (n_{an} \cdot t_{an}) + (n_{vcn} \cdot t_{vcn}) + (n_{dn} \cdot t_{dn})}}$$

$$n_m = \left\{ \frac{(n_{a1} \cdot t_{a1}) + (n_{vc1} \cdot t_{vc1}) + (n_{d1} \cdot t_{d1}) + \dots + (n_{an} \cdot t_{an}) + (n_{vcn} \cdot t_{vcn}) + (n_{dn} \cdot t_{dn})}{t_{a1} + t_{vc1} + t_{d1} + \dots + t_{an} + t_{vcn} + t_{dn}} \right\}$$

		F [N]	n [rpm]	time %
PHASE 1	Acceleration	Fa1	na1	ta1
	Constant speed	Fvc1	nvc1	tv1
	Deceleration	Fd1	nd1	td1
PHASE 2	Acceleration	Fa2	na2	ta2
	Constant speed	Fvc2	nvc2	tv2
	Deceleration	Fd2	nd2	td2
PHASE "n-1"	Acceleration	Fan-1	nan-1	tan-1
	Constant speed	Fvcn-1	nvcn-1	tvn-1
	Deceleration	Fdn-1	ndn-1	tdn-1
PHASE "n"	Acceleration	Fan	nan-1	tan-1
	Constant speed	Fvcn	nvcn-1	tvn-1
	Deceleration	Fdn	ndn-1	tdn-1
<b>TOTAL</b>				<b>100%</b>

## APPLICATION EXAMPLE

Phase 1	$F_{a1} = 142 \text{ N};$ $n_{a1} = 630 \text{ rpm};$ $t_{a1} = 0,7 \text{ %};$	$F_{vc1} = 98 \text{ N};$ $n_{vc1} = 1260 \text{ rpm};$ $t_{vc1} = 12,9 \text{ %};$	$F_{d1} = 54 \text{ N};$ $n_{d1} = 630 \text{ rpm};$ $t_{d1} = 0,7 \text{ %};$
Phase 2	$F_{a2} = 616 \text{ N};$ $n_{a2} = 450 \text{ rpm};$ $t_{a2} = 4,8 \text{ %};$	$F_{vc2} = 589 \text{ N};$ $n_{vc2} = 900 \text{ rpm};$ $t_{vc2} = 33,3 \text{ %};$	$F_{d2} = 562 \text{ N};$ $n_{d2} = 450 \text{ rpm};$ $t_{d2} = 4,8 \text{ %};$
Phase 3	$F_{a3} = 997 \text{ N};$ $n_{a3} = 240 \text{ rpm};$ $t_{a3} = 7,1 \text{ %};$	$F_{vc3} = 981 \text{ N};$ $n_{vc3} = 480 \text{ rpm};$ $t_{vc3} = 28,6 \text{ %};$	$F_{d3} = 965 \text{ N};$ $n_{d3} = 240 \text{ rpm};$ $t_{d3} = 7,1 \text{ %};$

in this way it is possible to determine:

$$K_1 = (F_{a1}^3 \cdot n_{a1} \cdot t_{a1}) + (F_{vc1}^3 \cdot n_{vc1} \cdot t_{vc1}) + (F_{d1}^3 \cdot n_{d1} \cdot t_{d1}) \quad n_1 = (n_{a1} \cdot t_{a1}) + (n_{vc1} \cdot t_{vc1}) + (n_{d1} \cdot t_{d1}) \quad T_1 = t_{a1} + t_{vc1} + t_{d1}$$

$$K_2 = (F_{a2}^3 \cdot n_{a2} \cdot t_{a2}) + (F_{vc2}^3 \cdot n_{vc2} \cdot t_{vc2}) + (F_{d2}^3 \cdot n_{d2} \cdot t_{d2}) \quad n_2 = (n_{a2} \cdot t_{a2}) + (n_{vc2} \cdot t_{vc2}) + (n_{d2} \cdot t_{d2}) \quad T_2 = t_{a2} + t_{vc2} + t_{d2}$$

$$K_3 = (F_{a3}^3 \cdot n_{a3} \cdot t_{a3}) + (F_{vc3}^3 \cdot n_{vc3} \cdot t_{vc3}) + (F_{d3}^3 \cdot n_{d3} \cdot t_{d3}) \quad n_3 = (n_{a3} \cdot t_{a3}) + (n_{vc3} \cdot t_{vc3}) + (n_{d3} \cdot t_{d3}) \quad T_3 = t_{a3} + t_{vc3} + t_{d3}$$

Concluding, we know that:

$$F_m = \sqrt[3]{\frac{(K_1 + K_2 + K_3)}{(n_1 + n_2 + n_3)}} = 596,64 \text{ N}$$

$$n_m = \frac{n_1 + n_2 + n_3}{T_1 + T_2 + T_3} = 685,7 \text{ rpm}$$

		F [N]	n [rpm]	time %
PHASE 1	Acceleration	142	630	0.7
	Constant speed	98	1260	12.9
	Deceleration	54	630	0.7
PHASE 2	Acceleration	616	450	4.8
	Constant speed	589	900	33.3
	Deceleration	562	450	4.8
PHASE 3	Acceleration	997	240	7.1
	Constant speed	981	480	28.6
	Deceleration	965	240	7.1
<b>TOTAL</b>				<b>100.0</b>

## HOW TO CALCULATE THE DRIVING TORQUE [Nm]

$F_A$  = Total force acting from outside [N]

$p$  = Pitch of the ball screw [mm]

$\eta$  = Performance

$C_{M1}$  = Driving torque due to external agents [Nm]

$$C_{TOT} = C_{M1} + C_{M2} + C_{M3}$$

$$C_{M1} = \frac{F_A \cdot p}{2\pi \cdot 1000} \cdot \frac{1}{\eta}$$

$J_{TOT}$  = Moment of inertia of rotating components [kg·m<sup>2</sup>]

$J_F$  = Moment of inertia of fixed-length rotating components [kg·m<sup>2</sup>]

$J_V$  = Moment of inertia of variable-length rotating components [kg·m<sup>2</sup>]

$K_V$  = Coefficient of inertia of variable-length rotating components [kg·mm<sup>2</sup>/m]

$C$  = Rod stroke [mm]

$\dot{\omega}$  = Angular acceleration [rad/s<sup>2</sup>]

$a$  = Linear acceleration of the ball screw [m/s<sup>2</sup>]

$C_{M2}$  = Driving torque due to rotating components [Nm]

$$J_{TOT} = (J_F + J_V) \cdot 10^{-6}$$

$$J_V = K_V \cdot C$$

$$\dot{\omega} = \frac{a \cdot 2\pi \cdot 1000}{p}$$

$$C_{M2} = J_{TOT} \cdot \dot{\omega} \cdot \frac{1}{\eta}$$

$F_{TT}$  = Force needed to move sliding components [N]

$F_{TF}$  = Force needed to move fixed-length sliding components [N]

$F_{TV}$  = Force needed to move variable-length sliding components [N]

$m_{c1}$  = Mass of the fixed-length sliding components [kg]

$K_{TV}$  = Mass coefficient of variable-length sliding components [kg/mm]

$C_{M3}$  = Driving torque due to sliding components [Nm]

$$F_{TT} = F_{TF} + F_{TV}$$

$$F_{TF} = m_{c1} \cdot a$$

$$F_{TV} = K_{TV} \cdot C \cdot a$$

$$C_{M3} = \frac{F_{TT} \cdot p}{2\pi \cdot 1000} \cdot \frac{1}{\eta}$$

**Life of the cylinder according to the average axial force applied (environmental T and standard conditions of use)**

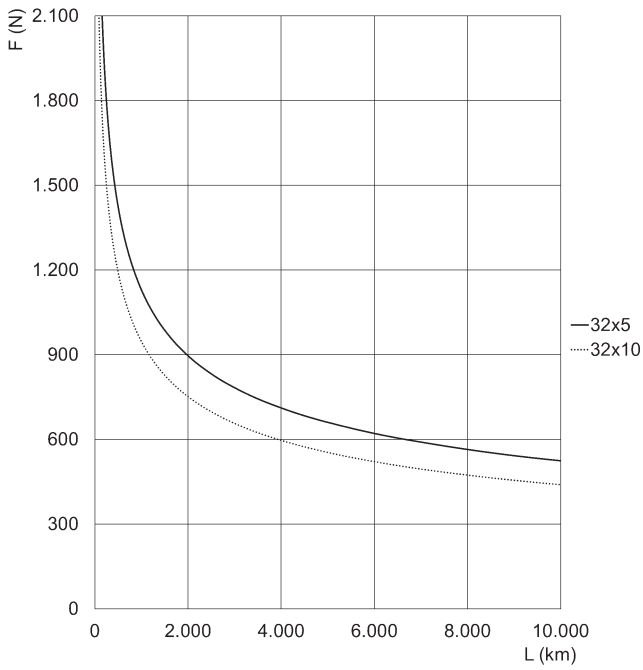

Size 32

F = Axial Force [N]  
L = life [km]  
Curves calculated with  $f_w = 1$

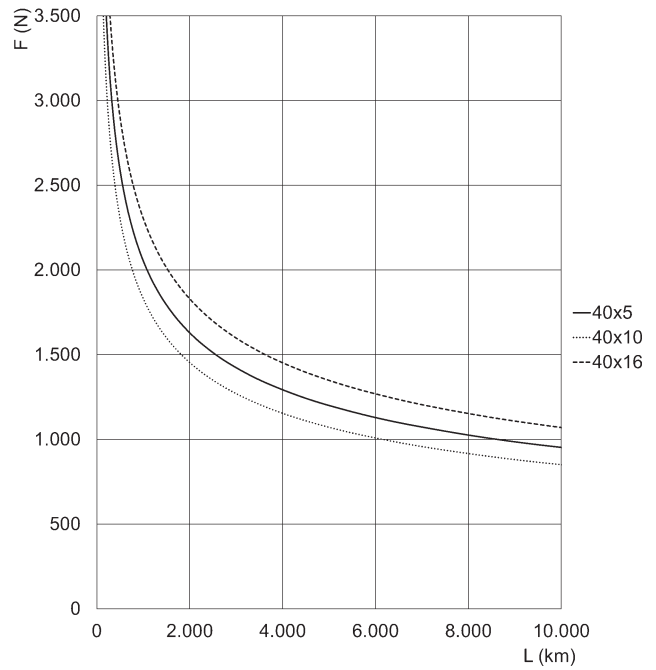

Size 40

F = Axial Force [N]  
L = life [km]  
Curves calculated with  $f_w = 1$

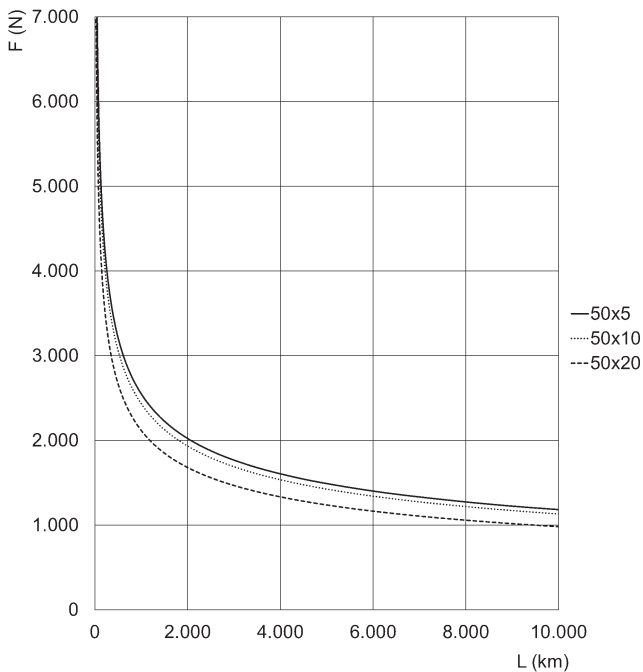

Size 50

F = Axial Force [N]  
L = life [km]  
Curves calculated with  $f_w = 1$

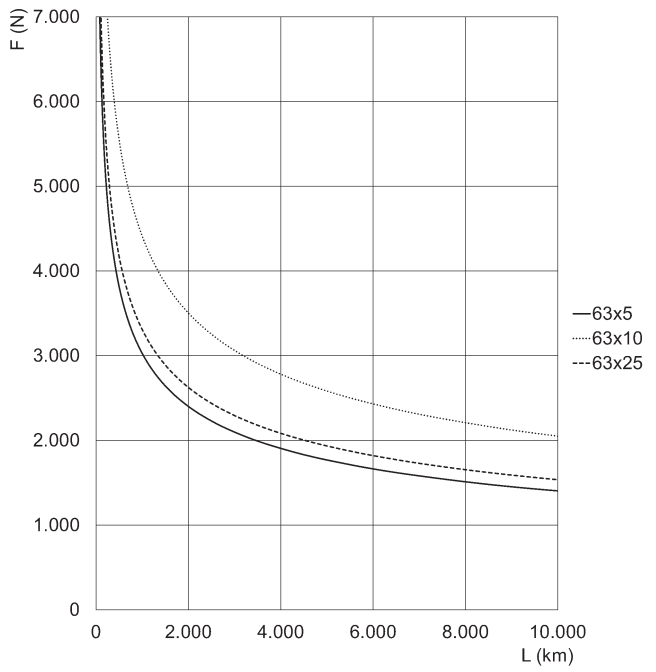

Size 63

F = Axial Force [N]  
L = life [km]  
Curves calculated with  $f_w = 1$



**Life of the cylinder according to the average axial force applied (environmental T and standard conditions of use)**

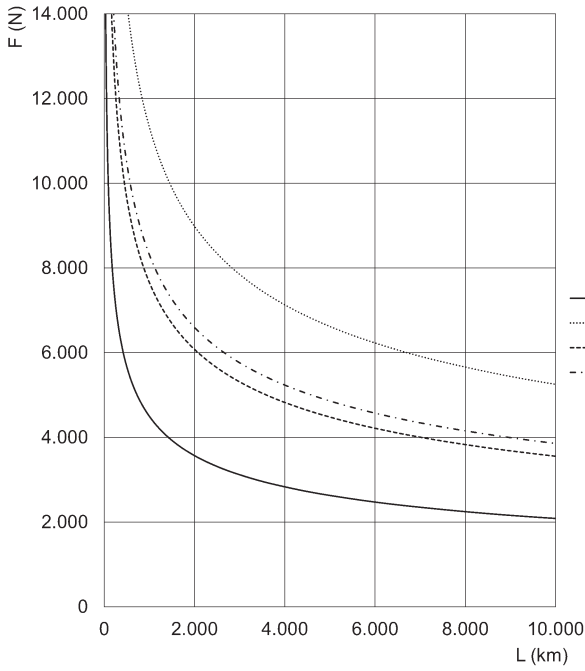

Size 80

F = Axial Force [N]  
L = life [km]  
Curves calculated with  $f_w = 1$

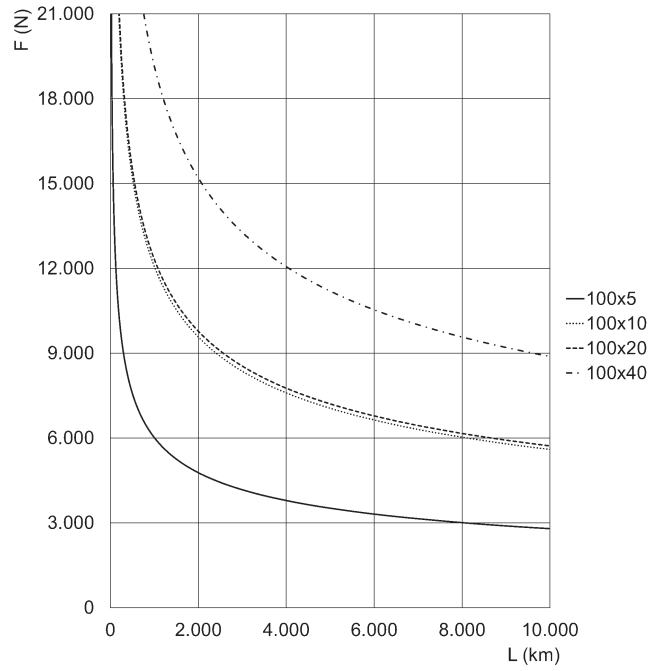

Size 100

F = Axial Force [N]  
L = life [km]  
Curves calculated with  $f_w = 1$

**Maximum speed of the cylinder according to its stroke**

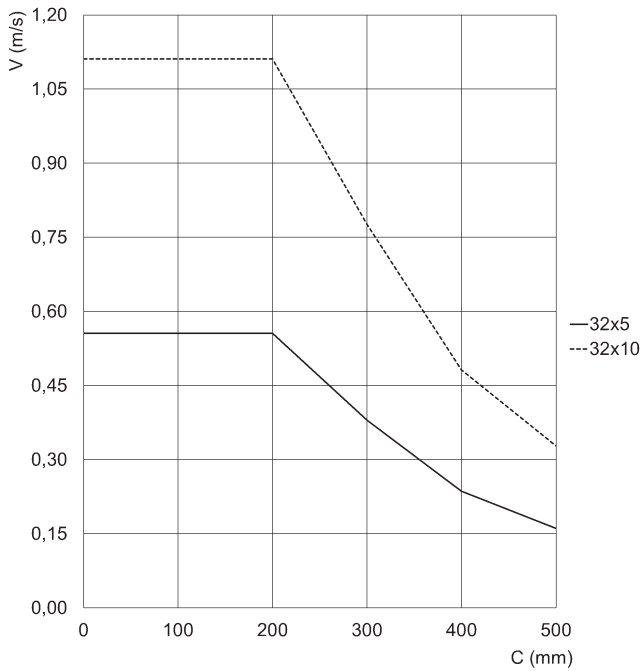

Size 32

V = speed [m/s]  
c = stroke [mm]

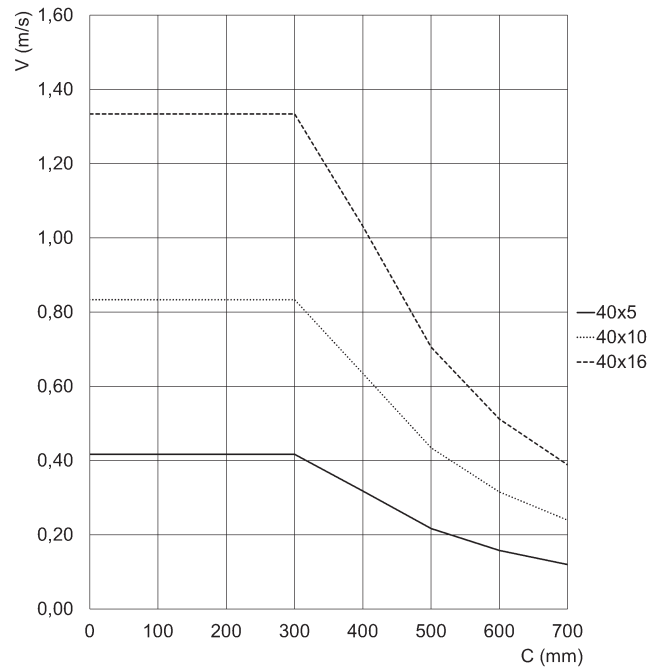

Size 40

V = speed [m/s]  
c = stroke [mm]

### Maximum speed of the cylinder according to its stroke

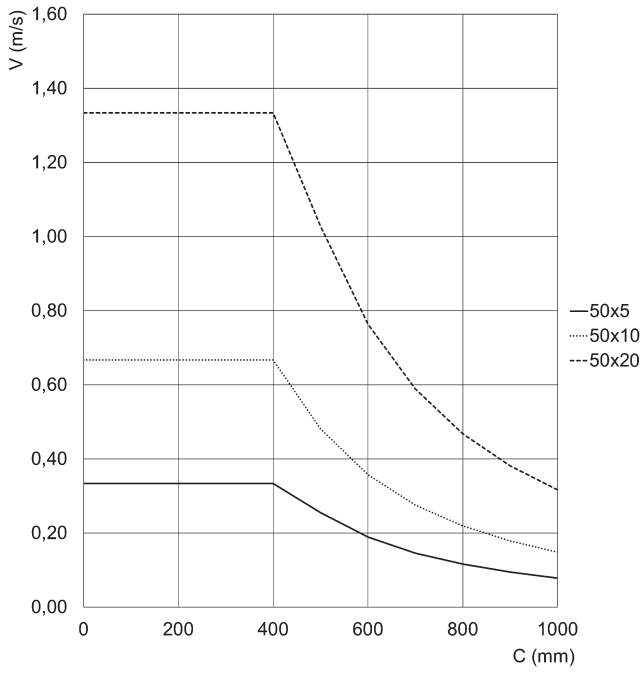

Size v

V = speed [m/s]  
c = stroke [mm]

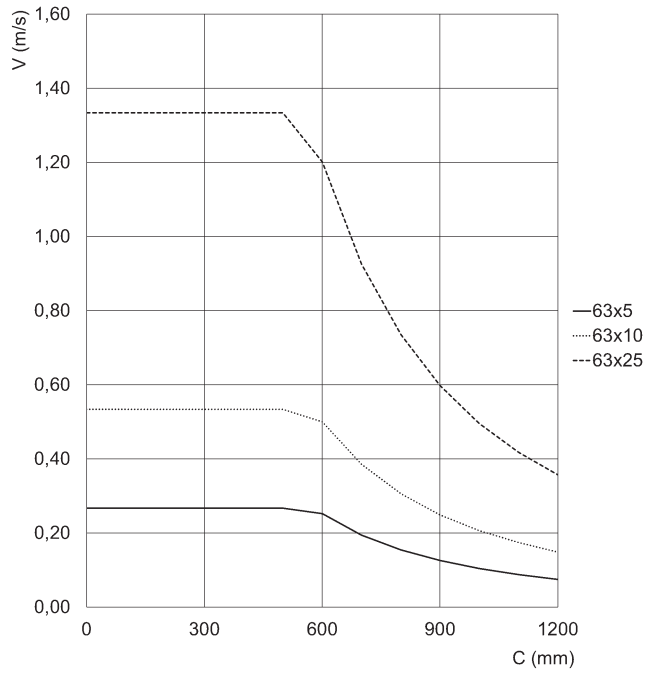

Size 63

V = speed [m/s]  
c = stroke [mm]

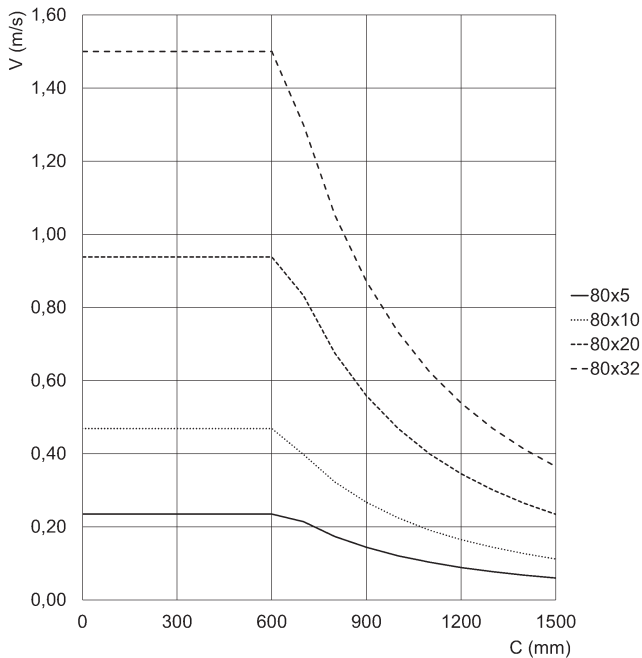

Size 80

V = speed [m/s]  
c = stroke [mm]

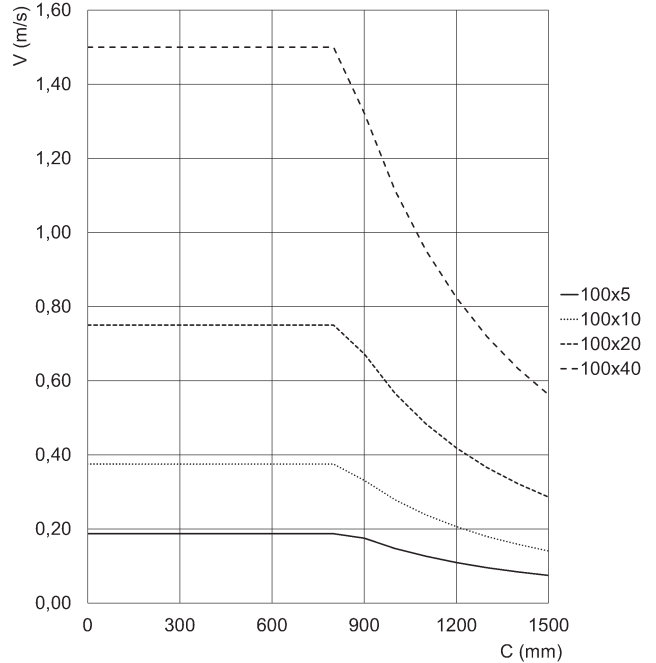

Size 100

V = speed [m/s]  
c = stroke [mm]

**Maximum force of the cylinder according to its stroke**

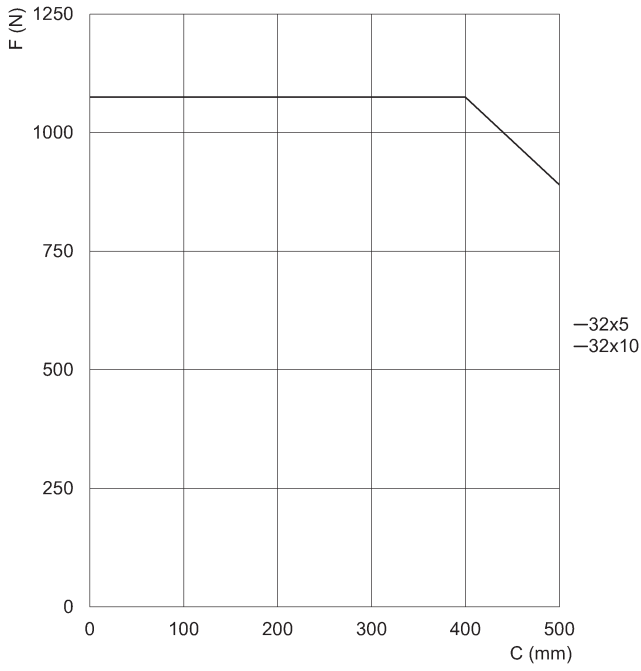

Size 32

F = static axial Force [N]  
c = stroke [mm]

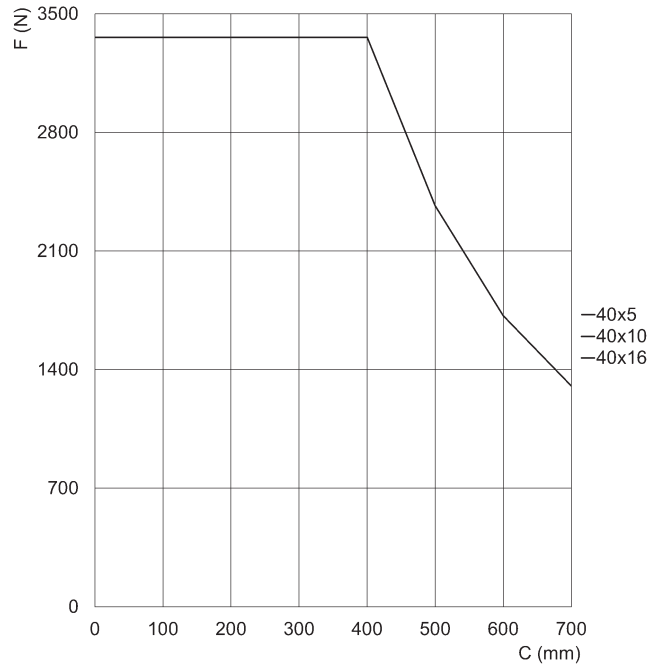

Size 40

F = static axial Force [N]  
c = stroke [mm]

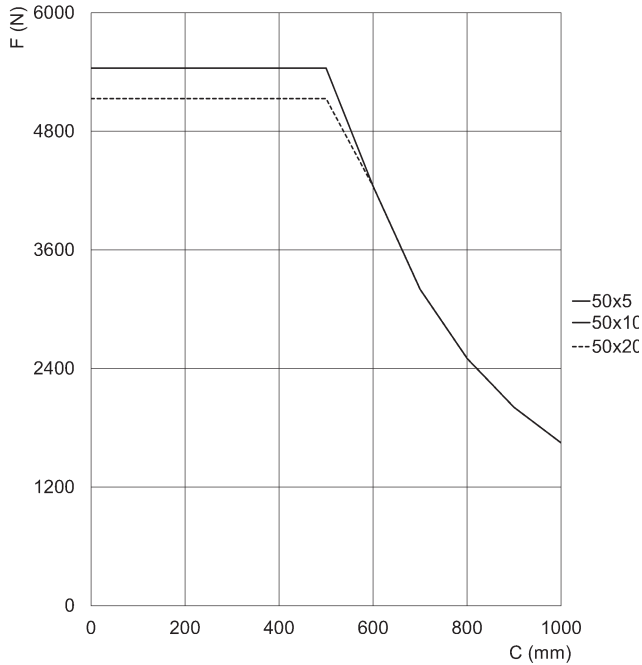

Size 50

F = static axial Force [N]  
c = stroke [mm]

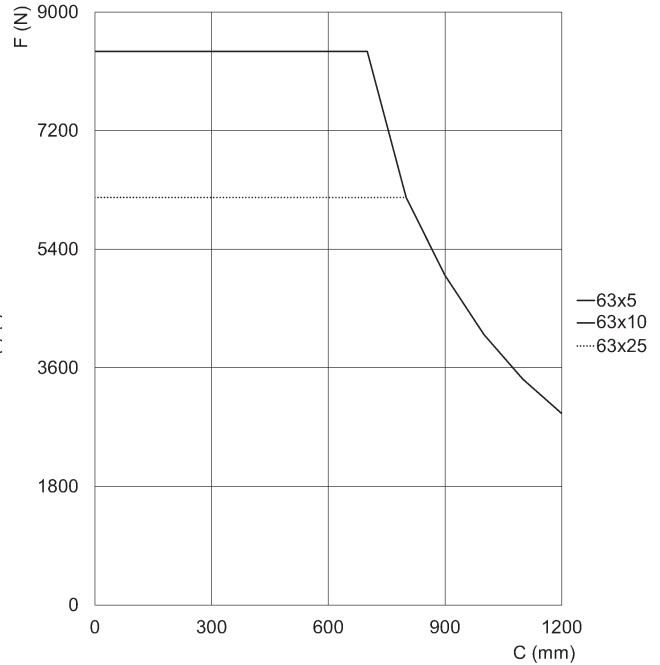

Size 63

F = static axial Force [N]  
c = stroke [mm]

### Maximum force of the cylinder according to its stroke

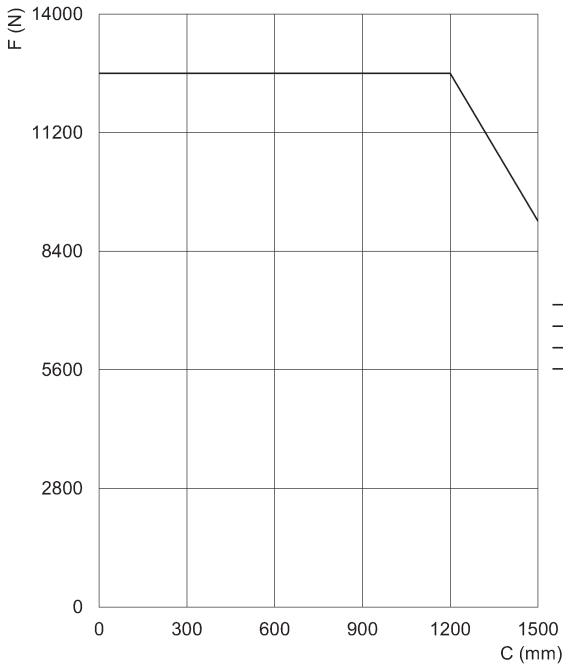

Size 80

F = static axial Force [N]  
c = stroke [mm]

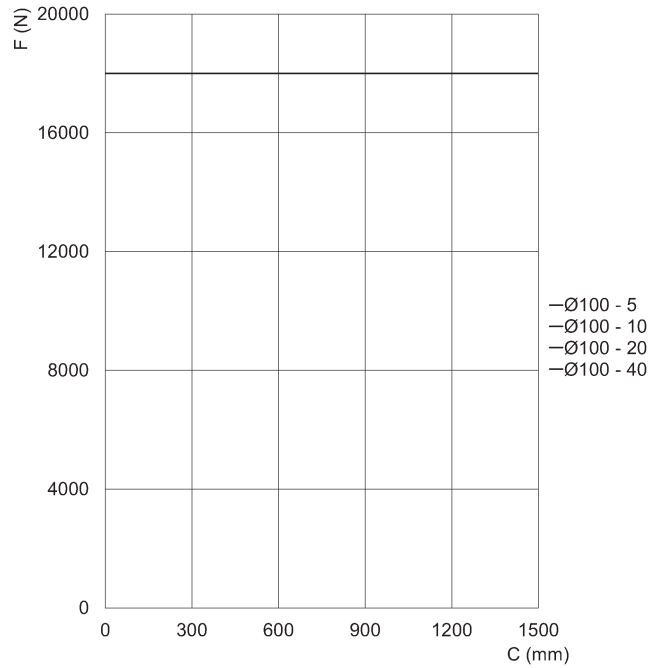

Size 100

F = static axial Force [N]  
c = stroke [mm]

### Series 6E cylinders

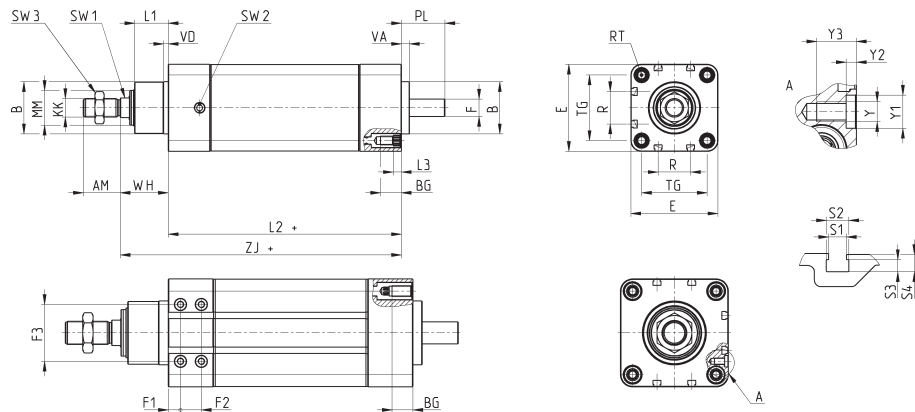

+ = add the stroke  
\*Dimension not in compliance with ISO 15552 standard

Size	AM	B	BG	E <sup>(e10)</sup>	F <sup>(h7)</sup>	F1	F2	F3	KK	L1	L2+	L3	MM	R	RT	PL	SW1	SW2	SW3	TG	VA	VD	Y	Y1	Y2	Y3	WH	ZJ+	S1	S2	S3	S4
32	22	30	16	46,5	8	-	-	-	M10x1,25	20	125	5,5	18	13	M6	21	10	G1/8	17	32,5	6	4	-	-	-	30	155	5,4	6,8	3,65	5	
40	24	35	16	55,4	10	-	-	-	M12x1,25	22	142	5,5	22	13,5	M6	24	13	G1/8	19	38	6	4	-	-	-	33	175	5,4	6,8	3,65	5	
50	32	40	16	64,9	12	-	-	-	M16x1,5	26	173	5,5	25	16	M8	30	17	G1/8	24	46,5	7	4	-	-	-	38	211	5,4	6,8	3,65	5	
63	32	45	16	75	15	-	-	-	M16x1,5	29	201	5,5	30	28	M8	38	17	G1/8	24	56,5	7	4	-	-	-	42	242,5	5,4	6,8	3,65	5	
80	40	55*	18	93	19	10,5	18	49	M20x1,5	35	211	-	40	30	M10	39	22	G1/4	30	72	8	8	M6	10	3	12	49	260	5,4	6,8	3,65	5
100	40	65*	18	115	24	13	18	62	M20x1,5	38	232	-	50	40	M10	42	22	G1/4	30	89	8	8	M8	12	3	16	51	283	5,4	6,8	3,65	5

### Housing for axial connection Mod. CM

Material: anodized aluminium



Supplied with:  
1x housing  
4x screws

+ = add the stroke

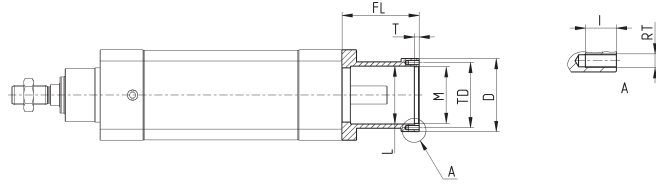
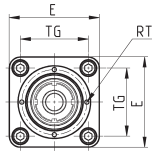

Mod.	Size	XT	E	$\varnothing D$	TG	FL	$\varnothing L$	$\varnothing M^{(H7)}$	T	TD	RT	I	Weight (g)
CM-6E-32	32	201	46,5	42	32,5	46	29	32	4	37	M3	9	100
CM-6E-40	40	224	55,4	52	38	49	36	37	4	43	M3	9	150
CM-6E-50	50	267	64,9	58	46,5	56	39	42	4	49	M4	9	225
CM-6E-63	63	306,5	75	60,5	56,5	64	48	47	4	54	M4	9	280

### Flange for axial connection Mod. FM

Material: anodized aluminium



Supplied with:  
1x flange  
1x flexible coupling  
4x screws  
4x motor connection screws

+ = add the stroke

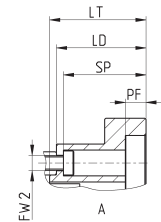
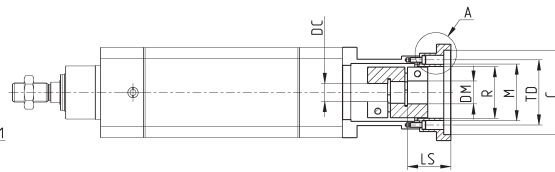
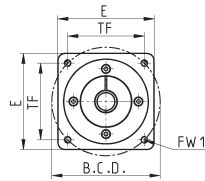

Mod.	Size	Housing	Motor	XR	$\varnothing C^{(H7)}$	PF	LT	LD	$\varnothing M^{(H7)}$	E	$\varnothing R$	TF	$\varnothing B.C.D.$	FW1	$\varnothing TD$	SP	FW2	$\varnothing DC$	$\varnothing DM$	LS	Nominal torque (Nm) <sup>(A)</sup>	Max torque J (Kgmm <sup>2</sup> ) (Nm) <sup>(B)</sup>	Weight (g)	$\eta$	
FM-6E-32-0100	32	CM-6E-32	MTB-010-...	210	30	6	11	9	32	42	29	-	45	M3	37	6	3,5	8	8	22	9	18	2	65	0,78
FM-6E-32-0023	32	CM-6E-32	MTS-23-...	208	38,1	5	9	7	32	56,4	29	47,1	-	M4	37	5	3,5	8	6,35	25	9	18	2	140	0,78
FM-6E-40-0400	40	CM-6E-40	MTB-040-...	242	50	3,5	20	18	37	60	33	-	70	M5	43	3,5	3,5	10	14	40	12,5	25	3	140	0,78
FM-6E-40-0023	40	CM-6E-40	MTS-23-...	231	38,1	5	9	7	37	56,4	33	47,1	-	M4	43	5	3,5	10	6,35	29,3	12,5	25	3	215	0,78
FM-6E-50-0400	50	CM-6E-50	MTB-040-...	284	50	6	19	17	42	60	37	-	70	M5	49	14	4,5	12	14	37,3	12,5	25	3	210	0,78
FM-6E-50-0024	50	CM-6E-50	MTS-24-...	274	38,1	3	9	7	42	58	37	47,1	-	M4	49	4	4,5	12	8	29,3	12,5	25	3	190	0,78
FM-6E-63-0750	63	CM-6E-63	MTB-075-...	332,5	70	6	28	26	47	80	43	-	90	M6	54	24	4,5	15	19	54,8	17	34	10	565	0,78
FM-6E-63-0024	63	CM-6E-63	MTS-24-...	313,5	38,1	5	9	7	47	60,5	43	47,1	-	M4	54	5	4,5	15	8	29,3	12,5	25	3	200	0,78

<sup>(A)</sup> Continuously applicable torque, under ideal mounting and operating conditions. For further details, please contact [service@camozzi.com](mailto:service@camozzi.com)

<sup>(B)</sup> Torque applicable for short intervals, under ideal mounting and operating conditions. For further details, please contact [service@camozzi.com](mailto:service@camozzi.com)

**Kit for axial connection Mod. AM**



- Supplied with:  
 1x housing  
 1x flange  
 1x flexible coupling  
 4x screws to connect on the cylinder's side  
 4x screws to connect on the motor's side  
 3x seals  
 4x seal washers  
 4x motor connection screws

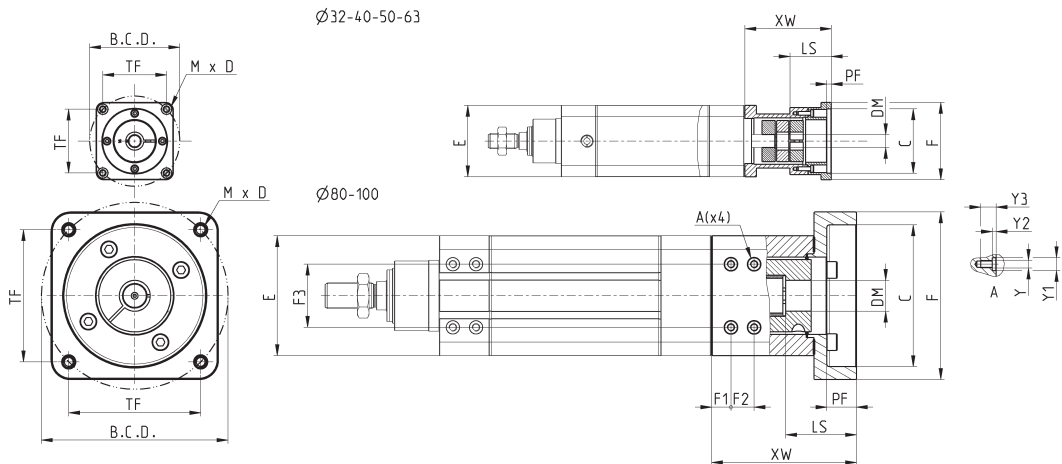

Mod.	Size	Protection class	$\varnothing_{DM}$	LS	$\varnothing_C$	PF	E	F	TF	$\varnothing_{B.C.D.}$	MxD	F1	F2	F3	Y	Y1	Y2	Y3	XW	Nominal torque (Nm) <sup>(A)</sup>	Max torque (Nm) <sup>(B)</sup>	J (Kgm <sup>2</sup> )	Weight (g)	$\eta$	
AM-6E-32-0100P	32	IP65	MTB-010-...	8	22	30	6	46,5	42	-	45	M3x9	-	-	-	-	-	-	55	9	18	2	165	0,78	
AM-6E-32-0023P	32	IP65	MTS-23-...	6,35	25	38,1	5	46,5	56,4	47,1	-	M4x7	-	-	-	-	-	-	53	9	18	2	240	0,78	
AM-6E-32-0024P	32	IP65	MTS-24-...	8	21,6	38,1	6	46,5	60	47,1	-	M4x7	-	-	-	-	-	-	53,5	9	18	2	240	0,78	
AM-6E-40-0400P	40	IP65	MTB-040-...	14	40	50	3,5	55,4	60	-	70	M5x8	-	-	-	-	-	-	67	12,5	25	3	290	0,78	
AM-6E-40-0023P	40	IP65	MTS-23-...	6,35	25	38,1	5	55,4	56,4	47,1	-	M4x7	-	-	-	-	-	-	56	12,5	25	2	365	0,78	
AM-6E-40-0024P	40	IP65	MTS-24-...	8	20,5	38,1	5	55,4	60	47,1	-	M4x8	-	-	-	-	-	-	55	12,5	25	3	365	0,78	
AM-6E-50-0400P	50	IP65	MTB-040-...	14	40	50	6	64,9	60	-	70	M5x9	-	-	-	-	-	-	73	12,5	25	3	435	0,78	
AM-6E-50-0750P	50	IP65	MTB-075-...	19	40	70	4,5	64,9	80	-	90	M6x12	-	-	-	-	-	-	86	17	34	10	746	0,78	
AM-6E-50-0024P	50	IP65	MTS-24-...	8	29,3	38,1	3	64,9	58	47,1	-	M4x7	-	-	-	-	-	-	63	12,5	25	3	415	0,78	
AM-6E-50-0034P	50	IP65	MTS-34-...	14	37,5	73	4,5	64,9	86	47,1	-	M6x12	-	-	-	-	-	-	83	17	34	10	785	0,78	
AM-6E-63-0750P	63	IP65	MTB-075-...	19	54,8	70	6	75	80	-	90	M6x12	-	-	-	-	-	-	90	17	34	10	845	0,78	
AM-6E-63-0024P	63	IP65	MTS-24-...	8	29,3	38,1	5	75	60,5	47,1	-	M4x7	-	-	-	-	-	-	71	12,5	25	3	480	0,78	
AM-6E-63-0034P	63	IP65	MTS-34-...	14	36,5	73	3,5	75	86	69,6	-	M6x12	-	-	-	-	-	-	88	17	34	10	1025	0,78	
AM-6E-80-1000P	80	IP65	MTB-100-...	24	55,7	110	23	93	130	-	90	M8x14	15	18	49	M6	10	3,1	12	112,5	60	120	40	2510	0,78
AM-6E-80-0034P	80	IP65	MTS-34-...	14	37,5	73	5	93	93	69,6	-	M6x15	15	18	49	M6	10	3,1	12	94,5	60	120	40	1885	0,78
AM-6E-100-1000P	100	IP65	MTB-100-...	24	55	110	23	115	130	-	145	M8x14	15	18	62	M8	12	3,1	18	115,5	60	120	40	3465	0,78
AM-6E-100-0034P	100	IP65	MTS-34-...	14	37,5	73	5	115	93	69,6	-	M6x15	15	18	62	M8	12	3,1	18	97,5	60	120	40	2840	0,78

<sup>(A)</sup> Continuously applicable torque, under ideal mounting and operating conditions. For further details, please contact service@camozzi.com

<sup>(B)</sup> Torque applicable for short intervals, under ideal mounting and operating conditions. For further details, please contact service@camozzi.com

## Kit for axial connection Mod. AR

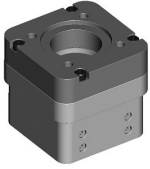

Supplied with:  
 2x flanges (1 for size 80)  
 8x screws  
 1x coupling  
 2x seals (1 for size 80)

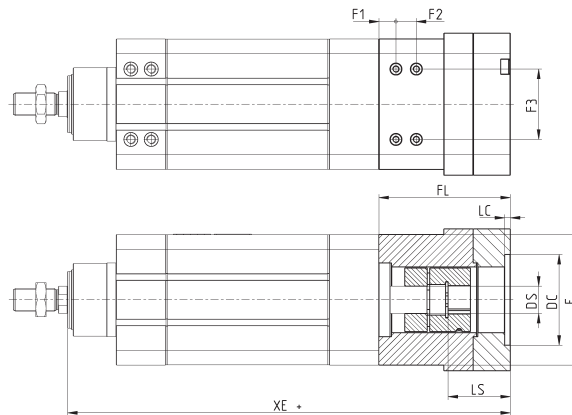
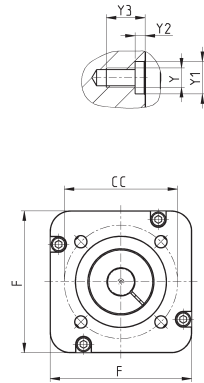

Mod.	Size	Protection class	Gearbox	XE+	FL	F	E	DC	LC	CC	F1	F2	F3	Y	Y1	Y2	Y3	DS	LS	Nominal torque (Nm) <sup>(A)</sup>	Max torque (Nm) <sup>(B)</sup>	J (Kgmm <sup>2</sup> )	Weight (g)	η
AR-6E-50-R060P	50	IP65	GB-060	288,2	77,2	-	64,9	40	3	52	-	-	-	-	-	-	-	14	35	16	32	3	630	0,78
AR-6E-63-R060P	63	IP65	GB-060	339,3	88,6	-	75	40	4	52	-	-	-	-	-	-	-	14	35	21	42	10	1100	0,78
AR-6E-80-R080P	80	IP65	GB-080	358	98	-	93	60	5	70	15	18	49	6	10	3,1	12	20	40	60	120	40	2090	0,78
AR-6E-100-R120P	100	IP65	GB-120	399,8	116,8	125	115	80	5	100	15	18	62	8	12	3,1	18	25	55	60	120	40	3800	0,78

<sup>(A)</sup> Continuously applicable torque, under ideal mounting and operating conditions. For further details, please contact [service@camozzi.com](mailto:service@camozzi.com)

<sup>(B)</sup> Torque applicable for short intervals, under ideal mounting and operating conditions. For further details, please contact [service@camozzi.com](mailto:service@camozzi.com)

## Kit for parallel connection Mod. PM



Detailed information about the size of interfaceable motors and reducers can be found further on in the dedicated sections.

- The kit includes:
- 1x front cover
  - 1x rear cover
  - 2x pulleys
  - 2x locking sets
  - 1x toothed belt
  - 1x belt traction unit
  - 4x screws for cylinder's side
  - 4x cover rear screws + seal washers
  - 6x cover fixing screws
  - 3x seals
  - 1x seal plug
  - 4x motor seal washers
  - 4x motor connection screws

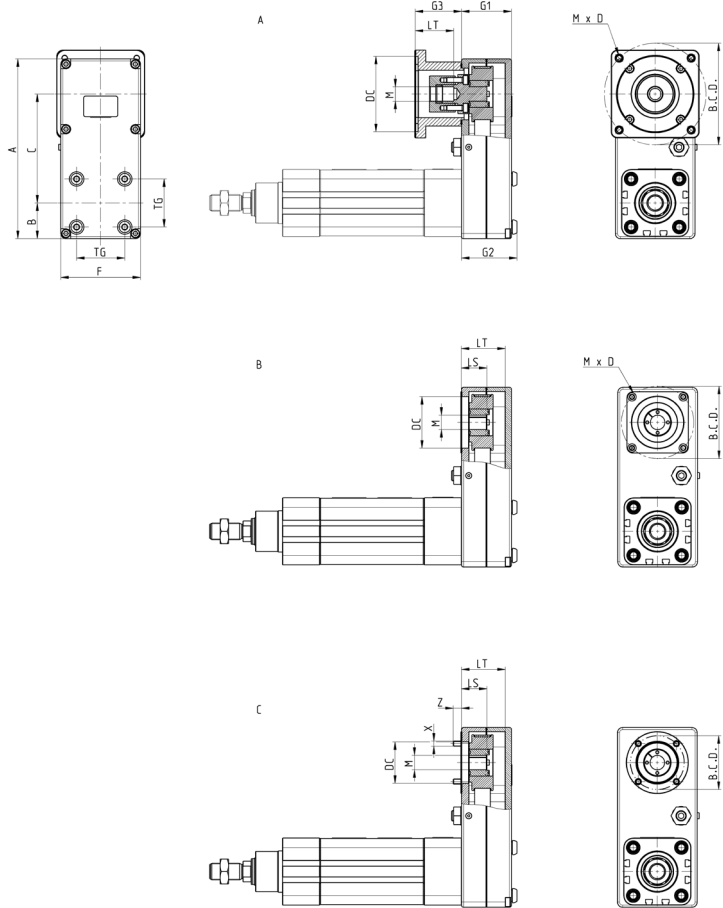

Mod.	Size	Type	Gearbox	Motor	G3	A	F	G1	G2	B	C	TG	gM	LS	LT	gDC	B.C.D.	MxD	X	Z	J (Kgmm <sup>2</sup> )	Weight (g)	η
PM-6E-32-0100P	32	B	-	MTB-010-...	-	122	54	35	39,2	26,5	65	32,5	8	18,5	29,5	30	45	M3x6	-	-	20,67	450	0,62
PM-6E-32-0024P	32	A	-	MTS-24-...	30	122	54	35	39,2	26,5	65	32,5	8	-	20,5	38,1	66,6	M4x10	-	-	27,78	450	0,62
PM-6E-40-0400P	40	B	-	MTB-040-...	-	154	67	46	50,2	30	90	38	14	25	40,6	50	70	M5x7	-	-	133,8	960	0,62
PM-6E-40-0024P	40	B	-	MTS-24-...	-	154	67	46	50,2	30	90	38	8	20,5	40,5	38,1	66,6	M4x7	-	-	90,3	960	0,62
PM-6E-50-0400P	50	B	-	MTB-040-...	-	174	77	48	53,4	34,5	105,5	46,5	14	24,5	42,5	50	70	M5x7	-	-	229,6	1375	0,62
PM-6E-50-0034P	50	A	-	MTS-34-...	44,5	174	77	48	53,4	34,5	105,5	46,5	14	-	47	73,025	98,42	M6x10	-	-	276,3	1375	0,62
PM-6E-50-R060P	50	C	GB-060-...	MTB-040-...	-	174	77	48	53,4	34,5	105,5	46,5	14	24,5	42,5	40	52	-	M5	8	229,6	1375	0,62
PM-6E-63-0750P	63	B	-	MTB-075-...	-	192	87	50	55,4	41	107	56,5	19	29,5	43,5	70	90	M6x8	-	-	357,1	1675	0,62
PM-6E-63-0034P	63	B	-	MTS-34-...	-	192	87	50	55,4	41	107	56,5	14	27,5	43,5	73,025	98,42	M6x8	-	-	244,5	1675	0,62
PM-6E-63-R060P	63	C	GB-060-...	MTB-040-...	-	192	87	50	55,4	41	107	56,5	14	27,5	43,5	40	52	-	M5	7,5	434,8	1675	0,62
PM-6E-80-1000P	80	B	-	MTB-100-...	-	310	135	70	77	65	180	72	24	41	60,5	110	145	M8x10	-	-	1053,1	4457	0,62
PM-6E-80-0034P	80	B	-	MTS-34-...	-	310	135	70	77	65	180	72	14	35	60,5	73,025	98,42	M6x10	-	-	970	4457	0,62
PM-6E-80-R080P	80	C	GB-080-...	MTB-075-...	-	310	135	70	77	65	180	72	19	36	60,5	60	70	-	M6	9,5	999,6	4457	0,62
PM-6E-100-1000P	100	B	-	MTB-100-...	-	310	135	70	77	65	180	72	24	41	60,5	110	145	M8x10	-	-	1110,8	4457	0,62
PM-6E-100-0034P	100	B	-	MTS-34-...	-	310	135	70	77	65	180	72	14	35	60,5	73,025	98,42	M6x10	-	-	1031,2	4457	0,62
PM-6E-100-R080P	100	C	GB-080-...	MTB-075-...	-	310	135	70	77	65	180	72	19	36	60,5	60	70	-	M6	9,5	1054,8	4457	0,62



**TRANSMISSIBLE POWER KIT PM**

The curves refer to a duty cycle of 70%

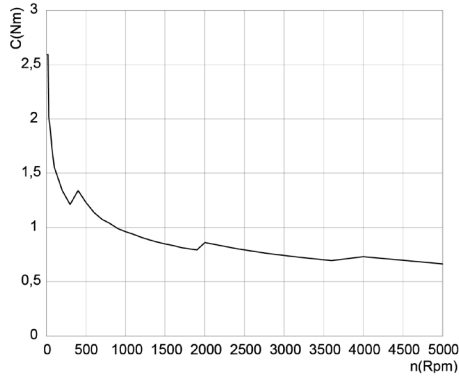

PM-6E 32...  
C = Torque [Nm]  
n = number of revolutions per minute

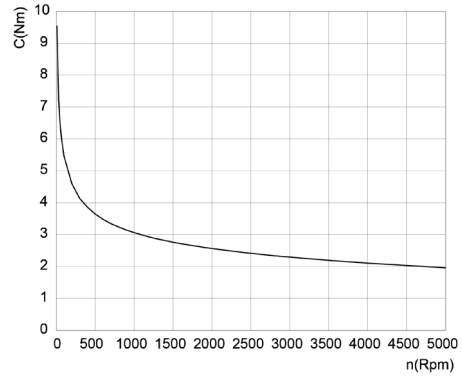

PM-6E 40...  
C = Torque [Nm]  
n = number of revolutions per minute

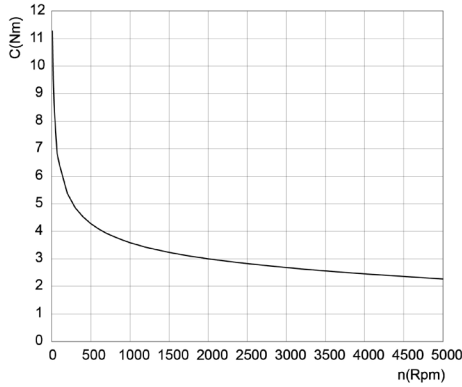

PM-6E 50...  
C = Torque [Nm]  
n = number of revolutions per minute

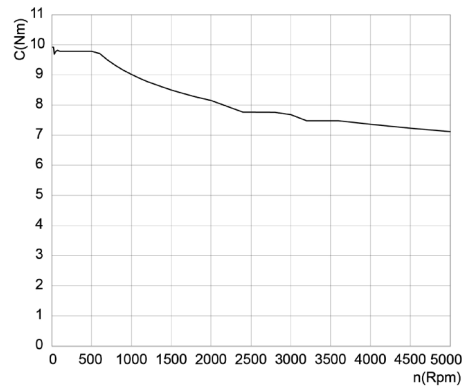

PM-6E 63...  
C = Torque [Nm]  
n = number of revolutions per minute

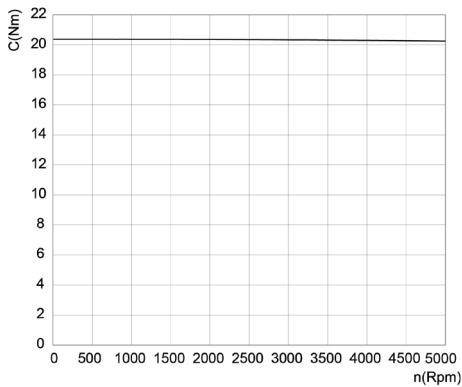

PM-6E 80...  
C = Torque [Nm]  
n = number of revolutions per minute

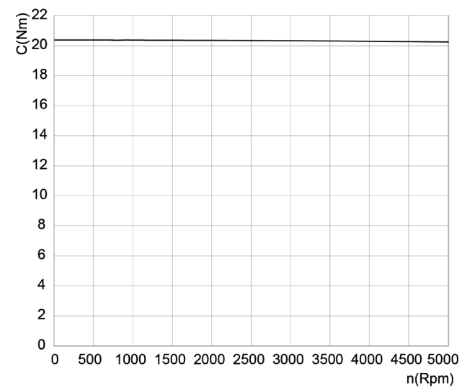

PM-6E 100...  
C = Torque [Nm]  
n = number of revolutions per minute

**Cylinder bracket Mod. BA-6E**

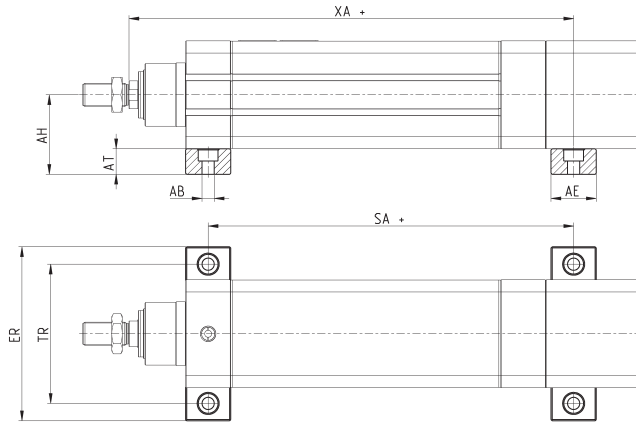
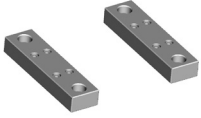

Supplied with:  
2x feet  
8x centering rings  
8x screws

SERIES 6E ELECTROMECHANICAL CYLINDERS

Mod.	Size	XA	AH	AT	AB	SA	ER	TR	AE	Weight (g)
BA-6E-80	80	283,85	68,5	22	10,5	215,5	150	120	39	630
BA-6E-100	100	306,85	79,5	22	10,5	234	170	140	44	800

## Foot bracket Mod. B-6E

Material: zinc-plated steel

Supplied with:  
2x feet  
8x screws



\* Mounting available for sizes 32, 40, 50 and 63 only

+ = add the stroke

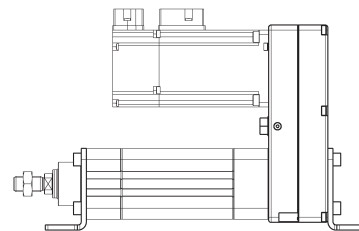
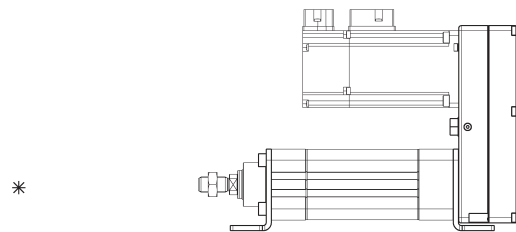
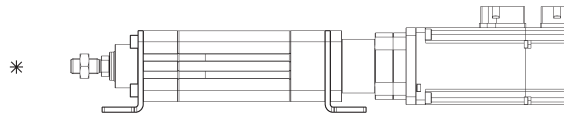
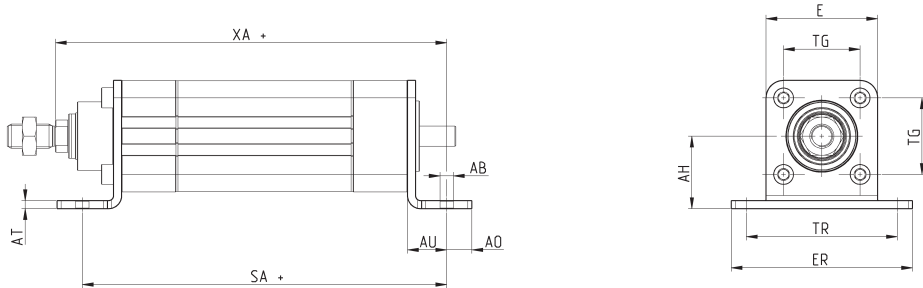

Mod.	Size	SA	XA	AH	TG	TR	AT	AU	AO	AB	ER	E	Weight (g)
B-6E-32	32	164	174,5	32	32,5	65	4	19,5	12,5	6,6	79	46,5	275
B-6E-40	40	181	194,5	36	38	75	4	19,5	12,5	6,6	90	55,4	340
B-6E-50	50	223	236	45	46,5	90	5	25	15	9	110	64,9	635
B-6E-63	63	251	267,5	50	56,5	100	5	25	15	9	120	75	755
B-6E-80	80	278	293,5	68,5	72	120	6	33,5	17,5	10,5	140	93	1300
B-6E-100	100	299	316,5	79,5	89	140	6	33,5	17,5	10,5	170	115	1800

### Front spot faced trunnion Mod. FN

Material: zinc-plated steel

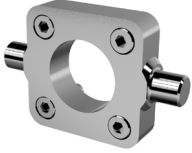

Supplied with:  
1x spot faced trunnion  
4x screws

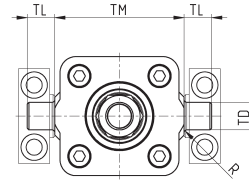
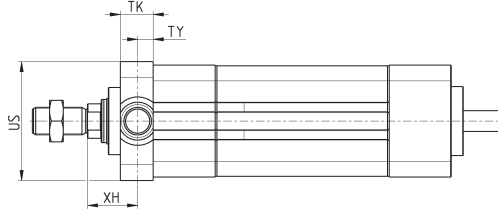

Mod.	Size	TK	TY	XH	US	TL	TM	$\varnothing$ TD	R
FN-32	32	14	6,5	23,5	46	12	50	12	1
FN-40	40	19	9	24	59	16	63	16	1,5
FN-50	50	19	9	29	69	16	75	16	1,6
FN-63	63	24	11,5	30,5	84	20	90	20	1,6
FN-6E-80	80	24	11,5	34,5	102	20	110	20	1,6
FN-6E-100	100	29	14	37	125	25	132	25	2

### Counter bracket for front trunnion Mod. BF

Material: aluminium

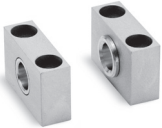

Supplied with:  
2x supports

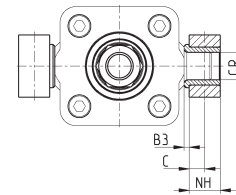
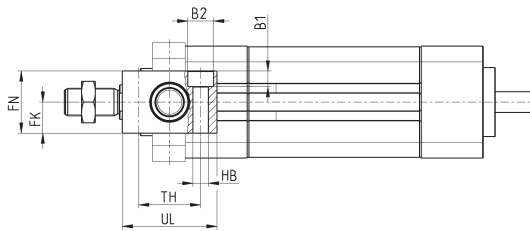

Mod.	Size	$\varnothing$ CR	NH	C	B3	TH	UL	FK	FN	B1	B2	HB
BF-32	32	12	15	7,5	3	32	46	15	30	6,8	11	6,6
BF-40-50	40 - 50	16	18	9	3	36	55	18	36	9	15	9
BF-63-80	63 - 80	20	20	10	3	42	65	20	40	11	18	11
BF-100-125	100 - 125	25	25	12,5	3,5	50	75	25	50	13	20	14

## Front flange Mod. D-E

Material: aluminium

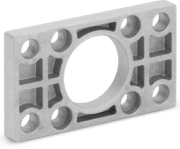

Supplied with:  
1x flange  
4x screws

+ = add the stroke

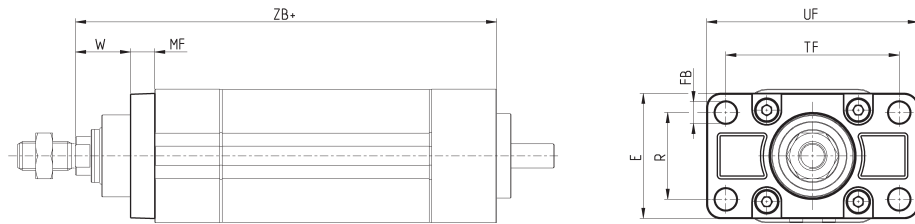

Mod.	Size	W	MF	ZB+	TF	R	UF	E	FB
D-E-41-32	32	20	10	155	64	32	80	45	7
D-E-41-40	40	23	10	175	72	36	90	52	9
D-E-41-50	50	26,5	12	211	90	43	110	65	9
D-E-41-63	63	30	12	242,5	100	50	120	75	9
D-E-6E-80	80	30	16	260	126	63	150	95	12
D-E-6E-100	100	35	16	283	150	75	170	115	14

## Side clamping bracket Mod. BG

Material: aluminium



Supplied with:  
2x clamps

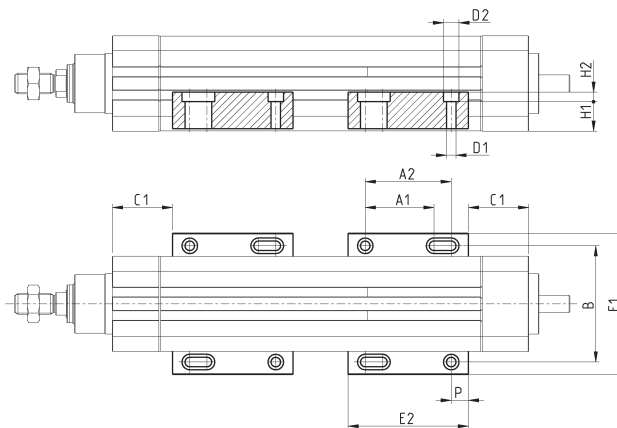

Mod.	Size	C1	E1	E2	P	A1	A2	B	Screw	øD1	øD2	H1	H2	Weight (g)
BG-6E-32	32	35	71	70	10	40	50	58,5	M4	4,5	7,5	13,8	4,5	80
BG-6E-40	40	35	82	70	10	40	50	67,5	M5	5,5	9	17,2	5,5	105
BG-6E-50	50	42	93	70	10	40	50	76,5	M6	6,5	10,5	19,9	6,5	125
BG-6E-63	63	42	103,5	70	10	40	50	87	M6	6,5	10,5	19,1	6,5	125
BG-6E-80	80	45	131	90	17,5	50	60	111,6	M8	8,5	14	24,5	8,5	260
BG-6E-100	100	50	153	90	17,5	50	60	133,6	M8	8,5	14	30,5	8,5	300

### Rear male trunnion Mod. L

Material: aluminium



Supplied with:  
1x male trunnion  
4x screws

+ = add the stroke

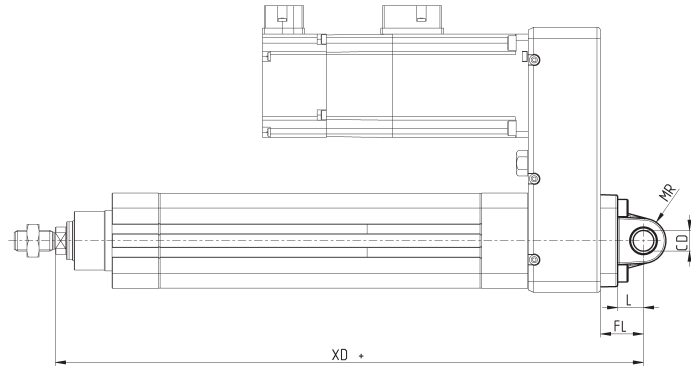
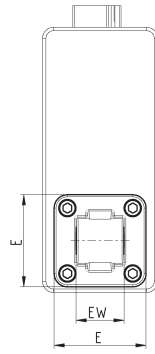

Mod.	Size	∅CD	L	FL	XD+	MR	E	EW
L-41-32	32	10	13	22	212	10	46	26
L-41-40	40	12	16	25	246	12	52	28
L-41-50	50	12	16	27	286	12	64	32
L-41-63	63	16	21	32	324,5	16	74	40
L-41-80	80	16	22	36	373	16	93	50
L-41-100	100	20	27	41	401	20	112	60

### Rear female trunnion Mod. C and C-H

Material: aluminium



Supplied with:  
1x female trunnion  
4x screws

+ = add the stroke

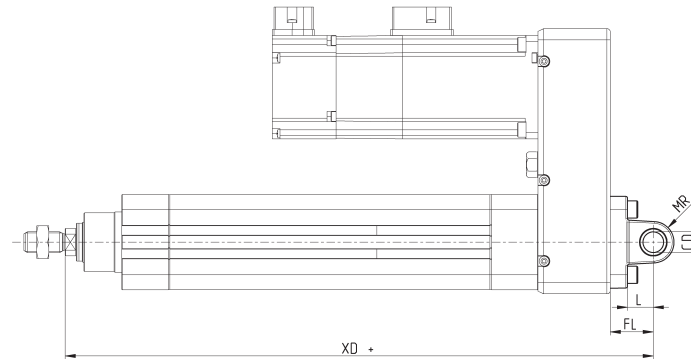
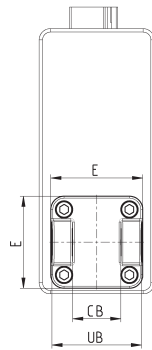

Mod.	Size	∅CD	L	FL	XD+	MR	E	CB	UB
C-41-32	32	10	13	22	212	10	46	26	45
C-41-40	40	12	16	25	246	12	52	28	52
C-41-50	50	12	16	27	286	12	64	32	60
C-H-41-63	63	16	21	32	324,5	16	74	40	70
C-H-41-80	80	16	22	36	373	16	93	50	90
C-H-41-100	100	20	27	41	401	20	112	60	110

### Accessory combination Mod. C+L+S

Material: aluminium



+ = add the stroke

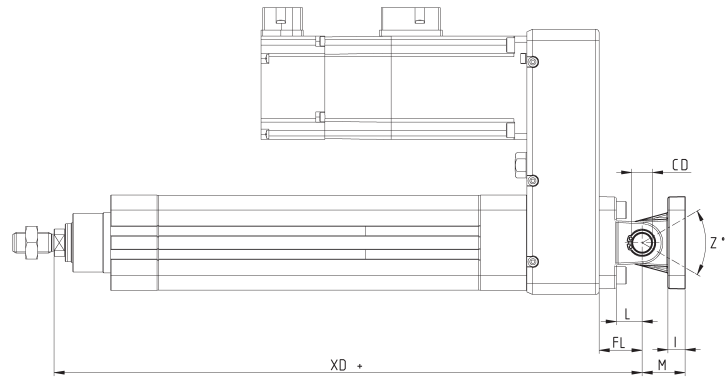
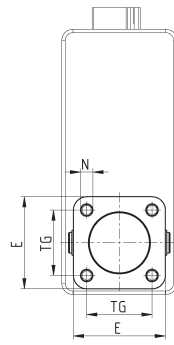

Mod.	Size	E	TG	$\varnothing$ N	XD+	$\varnothing$ CD	L	FL	I	M	Z' (max)
C+L+S	32	46	32.5	6.5	212	10	13	22	13	22	30
C+L+S	40	52	38	6.5	246	12	16	25	16	25	40
C+L+S	50	64	46.5	9	286	12	16	27	16	27	25
C+L+S	63	74	56.5	9	324.5	16	21	32	21	32	36
C+L+S	80	93	72	11	373	16	22	36	22	36	34
C+L+S	100	112	89	11	401	20	27	41	27	41	38

### 90° male trunnion Mod. ZC

CETOP RP 107P  
Material: aluminium

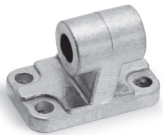

Supplied with:  
1x male support

+ = add the stroke

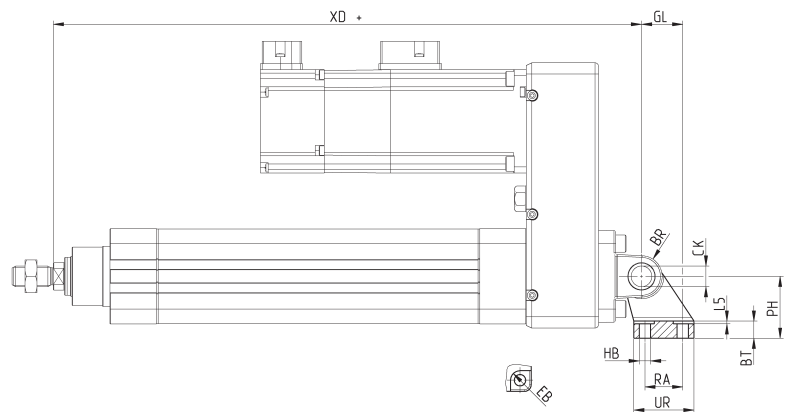
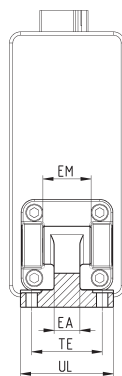

Mod.	Size	$\varnothing$ EB	$\varnothing$ CK	$\varnothing$ HB	XD+	TE	UL	EA	GL	L5	RA	EM	UR	PH	BT	BR
ZC-32	32	11	10	6,6	212	38	51	10	21	1,6	18	26	31	32	8	10
ZC-40	40	11	12	6,6	246	41	54	15	24	1,6	22	28	35	36	10	11
ZC-50	50	15	12	9	286	50	65	16	33	1,6	30	32	45	45	12	13
ZC-63	63	15	16	9	324,5	52	67	16	37	1,6	35	40	50	50	14	15
ZC-80	80	18	16	11	373	66	86	20	47	2,5	40	50	60	63	14	15
ZC-100	100	18	20	11	401	76	96	20	55	2,5	50	60	70	71	17	19

### Trunnion ball-joint Mod. R



\*This trunnion doesn't comply with the ISO 15552 standard  
Material: aluminium

Supplied with:  
1x trunnion ball joint  
4x screws

+ = add the stroke

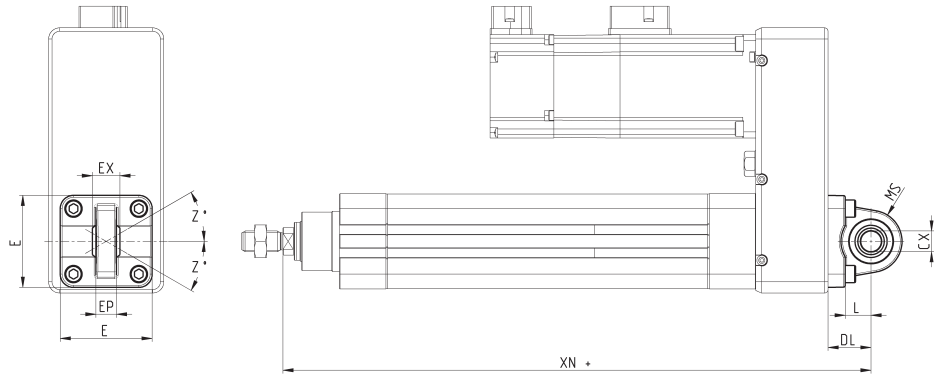

Mod.	Size	$\varnothing$ CX	L	DL	XN+	MS	E	EX	EP	Z
R-41-32	32	10	12	22	212	18	45	14	10,5	4°
R-41-40	40	12	15	25	246	18	53,5	16	12	4°
R-41-50	50	12*	15	27	286	21	62,5	16*	12*	4°
R-41-63	63	16	20	32	324,5	23	75	21	15	4°
R-41-80	80	16*	24	36	373	28	92	21*	15*	4°
R-41-100	100	20	29	41	401	30	115	25	18	4°
R-50	50	16	15	27	286	21	65	21	15	4°
R-80	80	20	20	36	373	28	95	25	18	4°

### Clevis pin Mod. S



Supplied with:  
1x clevis pin in stainless steel 303  
2x Seeger in steel

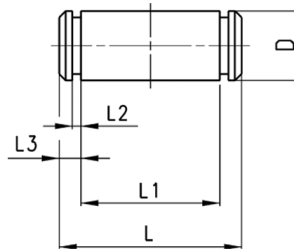

Mod.	Size	$\varnothing$ D	L	L1	L2	L3
S-32	32	10	52	46	1,1	3
S-40	40	12	59	53	1,1	3
S-50	50	12	67	61	1,1	3
S-63	63	16	77	71	1,1	3
S-80	80	16	97	91	1,1	3
S-100	100	20	121	111	1,3	5



## Swivel ball joint Mod. GA



ISO 8139.  
Material: zinc-plated steel

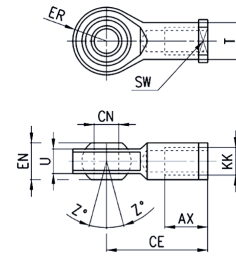

Mod.	$\phi$ CN <sup>(H7)</sup>	U	EN	ER	AX	CE	KK	$\phi$ T	Z	SW
GA-32	10	10,5	14	14	20	43	M10x1,25	15	6,5	17
GA-40	12	12	16	16	22	50	M12x1,25	17,5	6,5	19
GA-50-63	16	15	21	21	28	64	M16x1,5	22	7,5	22
GA-80-100	20	18	25	25	33	77	M20x1,5	27,5	7	30

## Piston rod socket joint Mod. GY



Material: zama and zinc-plated steel

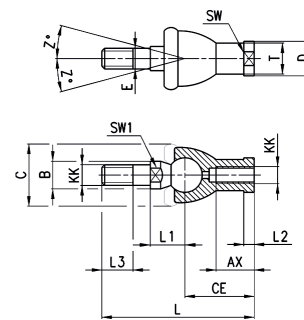

Mod.	Size	KK	AX	CE	E	L	L1	L2	L3	SW	SW1	$\phi$ B	$\phi$ C	$\phi$ D	$\phi$ T	Z
GY-32	32	M10x1,25	18	35	10	74	19,5	6,5	15	17	11	14	28	19	15	15
GY-40	40	M12x1,25	20	40	12	84	21	6,5	17	19	17	19	32	22	17,5	15
GY-50-63	50-63	M16x1,5	27	50	16	112	27,5	8	23	22	19	22	40	27	22	11
GY-80-100	80-100	M20x1,5	38	63	20	133	31,5	10	25	30	24	27	45	34	27,5	7,5

## Rod fork end Mod. G

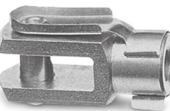

ISO 8140  
Material: zinc-plated steel

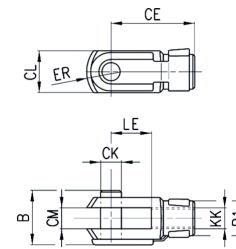

Mod.	$\phi$ CK	LE	CM	CL	ER	CE	KK	B	$\phi$ B1
G-25-32	10	20	10	20	12	40	M10x1,25	26	18
G-40	12	24	12	24	14	48	M12x1,25	32	20
G-50-63	16	32	16	32	19	64	M16x1,5	40	26
G-80-100	20	40	20	40	25	80	M20x1,5	48	34

## Piston rod lock nut Mod. U



ISO 4035  
Material: zinc-plated steel

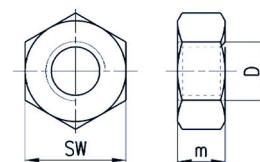

Mod.	D	m	SW
U-25-32	M10x1,25	6	17
U-40	M12x1,25	7	19
U-50-63	M16x1,5	8	24
U-80-100	M20x1,5	9	30

### Self aligning rod Mod. GK

Material: zinc-plated steel

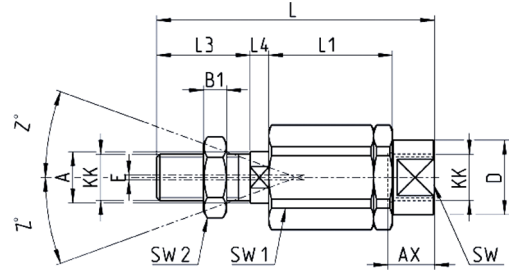
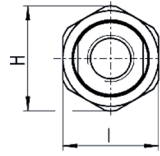

Mod.	Size	KK	L	L1	L3	L4	$\varnothing A$	$\varnothing D$	H	I	SW	SW1	SW2	B1	AX	Z	E
GK-25-32	32	M10x1,25	71,5	35	20	7,5	14	22	32	30	19	12	17	5	22	4	2
GK-40	40	M12x1,25	75,5	35	24	7,5	14	22	32	30	19	12	19	6	22	4	2
GK-50-63	50-63	M16x1,5	104	53	32	10	22	32	45	41	27	20	24	8	30	3	2
GK-80-100	80-100	M20x1,5	119	53	40	10	22	32	45	41	27	20	30	10	37	3	2

### Coupling piece Mod. GKF

Material: zinc-plated steel

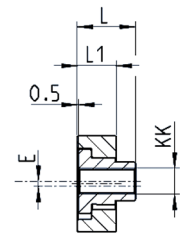
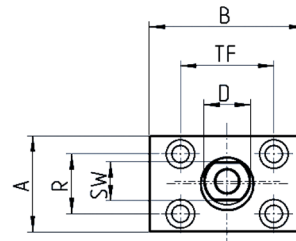
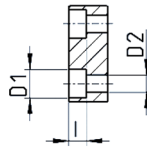

Mod.	Size	KK	A	B	R	TF	L	L1	I	$\varnothing D$	$\varnothing D1$	$\varnothing D2$	SW	E
GKF-25-32	32	M10x1,25	37	60	23	36	22,5	15	6,8	18	11	6,6	15	2
GKF-40	40	M12x1,25	56	60	38	42	22,5	15	9	20	15	9	15	2,5
GKF-50-63	50 - 63	M16x1,5	80	80	58	58	26,5	15	10,5	25	18	11	22	2,5
GKF-80-100	80 - 100	M20x1,5	90	90	65	65	32,5	20	13	30,5	20	14	27	2,5

### Slot cover profile Mod. S-CST-500

Supplied with 500 mm tube

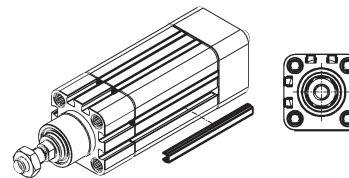

## Slot nut for sensor



Material: steel

Supplied with:  
2x nuts

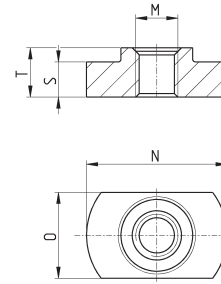

Mod.	Size	M	N	O	S	T
PCV-5E-CS-M3	50 - 65 - 80	M3	10,3	6,1	2,5	3,5
PCV-5E-CS-M4	50 - 65 - 80	M4	10,3	6,1	2,5	3,5

**GUIDE MOD.45NUT, 45NHT, 45NHB**

<b>45</b>	<b>N</b>	<b>UT</b>	<b>050</b>	<b>A</b>	<b>0100</b>
-----------	----------	-----------	------------	----------	-------------

<b>45</b>	SERIES
<b>N</b>	VERSION N = standard
<b>UT</b>	OPERATION UT = "U" self lubricating guide HT = "H" self lubricating guide HB = "H" ball guide
<b>050</b>	SIZE 032 = 32 040 = 40 050 = 50 063 = 63
<b>A</b>	MATERIALS A = anodized aluminium body - stainless steel AISI 420B columns for 45UT and 45HT - hardened steel C50 columns for 45HB
<b>0100</b>	STROKE in mm

SERIES 6E ELECTROMECHANICAL CYLINDERS

**45NUT GUIDES - APPLICABLE LOADS DEPENDING ON PROJECTION**

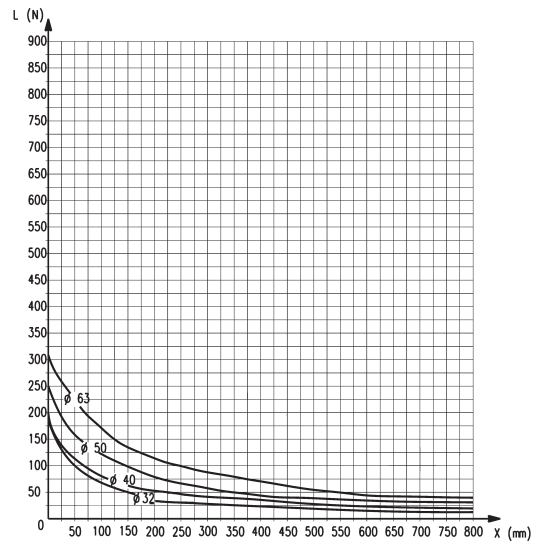
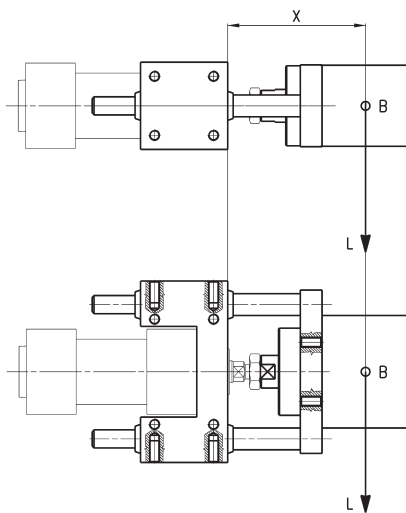

B = centre of gravity for applied load  
L = load  
X = fixed projection + stroke  
fixed projection = distance to the centre of gravity

Guide "U" moving on bush (45NUT)

**45NHB GUIDES - APPLICABLE LOADS DEPENDING ON PROJECTION**

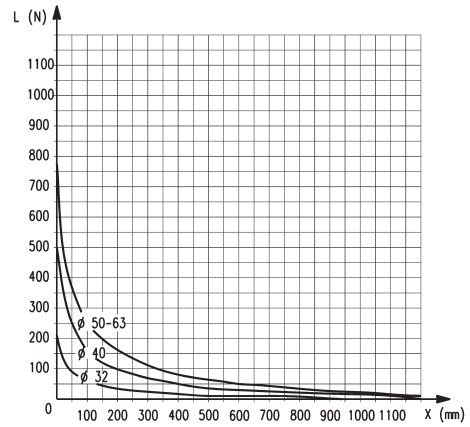
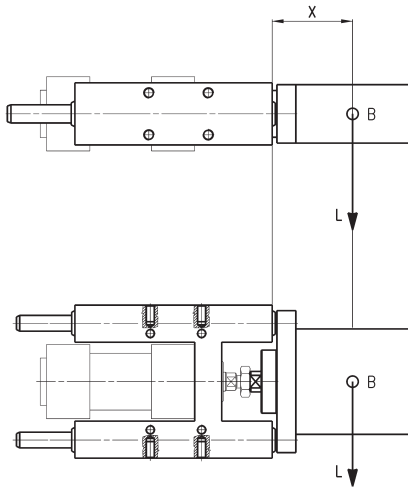

B = centre of gravity for applied load  
 L = load  
 X = fixed projection + stroke  
 fixed projection = distance to the centre of gravity

Guide "HB" with linear ball bearing (45NHB)

**45NHT GUIDES - APPLICABLE LOADS DEPENDING ON PROJECTION**

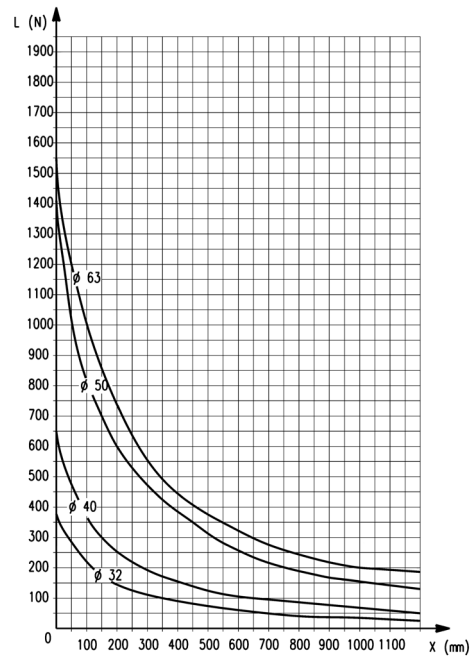
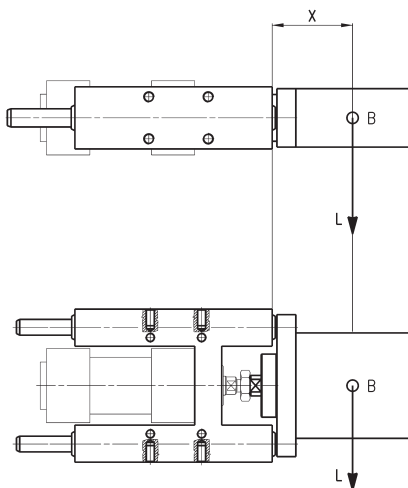

B = centre of gravity for applied load  
 L = load  
 X = fixed projection + stroke  
 fixed projection = distance to the centre of gravity

Guide "HT" moving on bush (45NHT)

### Guides Mod. 45NHT for cylinders Series 6E



Material body: anodized aluminium  
Coupling: stainless steel AISI 303

Supplied with:  
4x fixing screws.

Draw note:  
+ = add the stroke

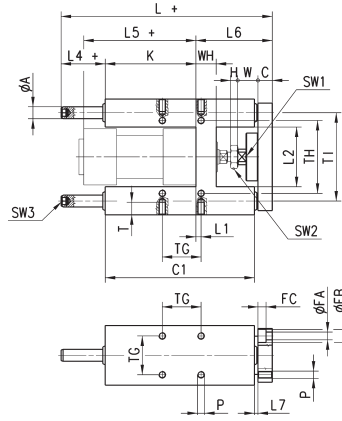
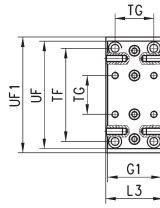

DIMENSIONS																														
Ø	TF	TG	TH	TI	UF	G1	UF1	∅A	WH	C1	H	W	C	K	L	L1	L2	L3	L4	L5	L6	L7	P	T	∅FA	∅FB	FC	SW1	SW2	SW3
32	78	32.5	61	74	90	45	97	12	17	125	6	17	12	76	177	4.3	50.2	50	37	94	64	3	M6	14	6.5	11	6.8	13	17	6
40	84	38	69	87	110	54	115	16	21	140	7	22	12	81	192	11	58.2	58	37	105	74	3	M6	14	6.5	11	6.8	15	19	6
50	100	46.5	85	104	130	63	137	20	26	149	8	26	15	78.5	205	19.8	70.2	70	37.5	106	89	3	M8	16	9	15	9	22	24	6
63	105	56.5	100	119	145	80	152	20	26	178	8	26	15	111	237	15.3	85.2	85	37	121	89	7	M8	16	9	15	9	22	24	6

### Guides Mod. 45NUT for cylinders Series 6E



Material body: anodized aluminium  
Coupling: stainless steel AISI 303

Supplied with:  
4x fixing screws.

Draw note:  
+ = add the stroke

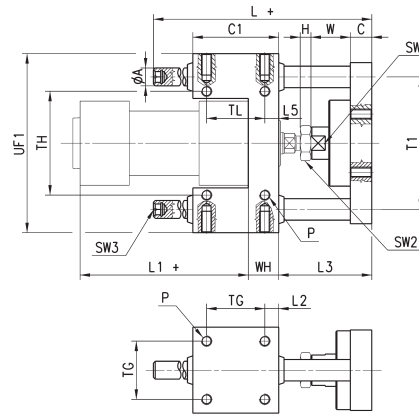
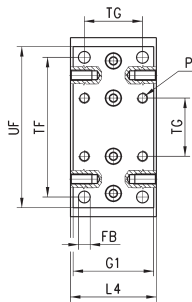

DIMENSIONS																									
Ø	TF	TG	TH	∅A	T1	P	FB	UF	G1	UF1	L	C1	H	W	C	L1	WH	L2	L3	L4	L5	TL	SW1	SW2	SW3
32	78	32,5	58	12	74	M6	6,6	90	45	100	106	48	6	22	12	94	17	7,8	52	48	7,8	32,5	15	17	6
40	84	38	64	12	80	M6	6,6	100	50	106	117	58	7	22	12	105	21	10	53	56	10	38	15	19	6
50	100	46,5	80	16	96	M8	9	120	60	125	129	59	8	26	15	106	25	6,2	64	66	6,3	46,5	22	24	6
63	105	56,5	95	16	104	M8	9	125	70	132	146	76	8	26	15	121	25	9,8	64	76	9,8	56,5	22	24	6

**Guides Mod. 45NHB for cylinders Series 6E**



Material body: anodized aluminium  
Coupling: stainless steel AISI 303

Supplied with:  
4x fixing screws.

Draw note:  
+ = add the stroke

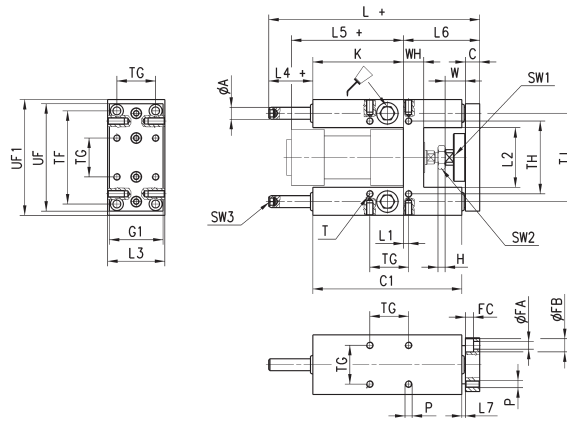

DIMENSIONS																														
∅	TF	TG	TH	TI	UF	G1	UF1	øA	WH	C1	H	W	C	K	L	L1	L2	L3	L4	L5	L6	L7	P	T	øFA	øFB	FC	SW1	SW2	SW3
32	78	32.5	61	74	90	45	97	12	17	125	6	17	12	76	177	4.3	50.2	50	37	94	64	3	M6	14	6.5	11	6.8	13	17	6
40	84	38	69	87	110	54	115	16	21	140	7	22	12	81	192	11	58.2	58	37	105	74	3	M6	14	6.5	11	6.8	15	19	6
50	100	46.5	85	104	130	63	137	20	26	149	8	26	15	78,5	237	19.8	70.2	70	69.5	106	89	3	M8	16	9	15	9	22	24	6
63	105	56.5	100	119	145	80	152	20	26	178	8	26	15	111	237	15.3	85.2	85	37	121	89	7	M8	16	9	15	9	22	24	6

**GUIDE MOD.6ENHT**

<b>6EN</b>	<b>HT</b>	<b>080</b>	<b>A</b>	<b>0100</b>
------------	-----------	------------	----------	-------------

<b>6EN</b>	MODEL
<b>HT</b>	OPERATION HT = "H" self lubricating guide
<b>080</b>	BORE 080 = 80 100 = 100
<b>A</b>	MATERIALS A = anodized aluminium body - stainless steel AISI 420B columns for 45UT and 45HT - hardened steel C50 columns for 45HB
<b>0100</b>	STROKE in mm

SERIES 6E ELECTROMECHANICAL CYLINDERS

**6ENHT GUIDES - APPLICABLE LOADS DEPENDING ON PROJECTION**

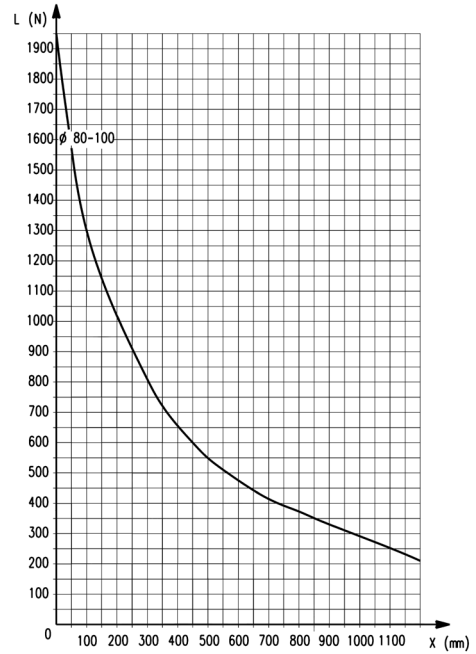
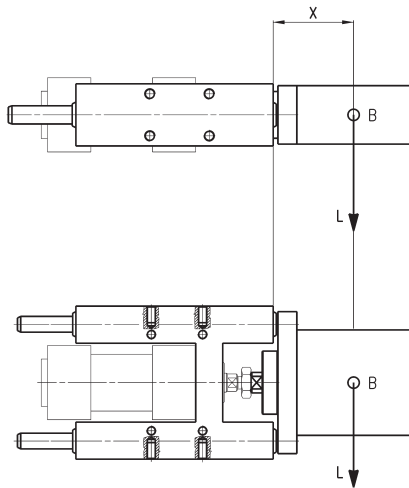

B = centre of gravity for applied load  
L = load  
X = fixed projection + stroke  
fixed projection = distance to the centre of gravity

Guide "HT" moving on bush (45NHT)



### Guides Mod. 6ENHT for cylinders Series 6E



Material Body: anodized aluminium  
Coupling: stainless steel AISI 303

Supplied with:  
4x fixing screws.

Draw note:  
+ = add the stroke

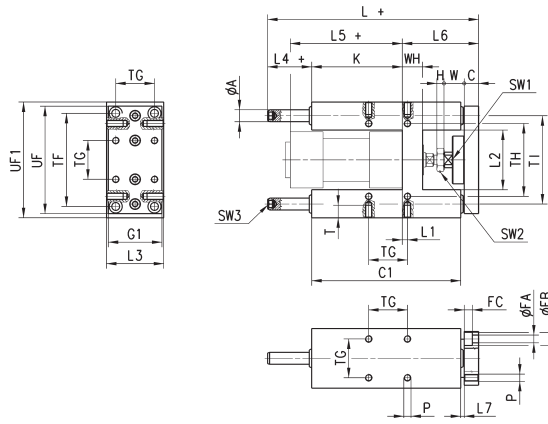

DIMENSIONS																														
∅	TF	TG	TH	TI	UF	G1	UF1	øA	WH	C1	H	W	C	K	L	L1	L2	L3	L4	L5	L6	L7	P	T	øFA	øFB	FC	SW1	SW2	SW3
80	130	72	130	148	180	100	189	25	34	195	9	32	20	128	280	21	105.4	105	42	128	110	23	M10	20	11	18	11	27	30	6
100	150	89	150	172	200	120	213	25	39	220	9	32	20	128	280	24.5	130.4	130	37	138	115	3	M10	20	11	18	11	27	30	6