

# Series ASX angle seat valves



2/2-way - Normally Closed (NC) and Normally Open (NO)  
2/2-way - Double Acting (DA)



- » High flow
- » Low resistance of the flow
- » Anti-water hammer design
- » Compliant with Directive PED 2014/68/UE
- » Compliant with Directive ATEX for Zones 1/21 - II 2G Ex h IIC T4 Gb and II 2D Ex h IIIC T135 °C Db -10 ≤ Ta ≤ +80 °C

Angle seat valves are available in different versions with regard to nominal diameter, type of fluid and process connections.

They are able to manage media that are corrosive or contain suspended solid particulate matter and can be used in applications with high operating temperatures.

The operation is determined by the pneumatic drive of a single acting, guided piston actuator with spring return. There are also models available with double acting actuators, without spring. For liquid media we recommend the models with flow direction under the seat. For gas or steam we recommend the models with flow direction above the seat.

## GENERAL DATA

### TECHNICAL FEATURES

Function	2/2 NC - 2/2 NO - 2/2 Double Acting
Operation	pneumatic, poppet type
Pneumatic connections	1/4 ... 4" with BSP/BSPT/NPT threads, flanged, welding ends, tri-clamp
Nominal diameter	DN8 ... DN100
Flow coefficient Kv (m <sup>3</sup> /h)	2.2 ... 132
Operating pressure	0 ÷ 2 ... 16 bar
Operating temperature	-10 ÷ 180 °C (standard seals) / 25 ÷ 220 °C (high temperature seals)
Media	water, air, steam, inert or corrosive liquids and gases (compatible with the materials in contact)
Viscosity	600 cSt. max
Installation	in any position

### MATERIALS IN CONTACT WITH THE MEDIUM

Body	316 stainless steel (DN8 ÷ DN80) / 304 stainless steel (DN100)
Seals	PTFE
Internal parts	316 stainless steel

### SPECIFICATIONS PNEUMATIC ACTUATOR

Actuator dimensions	Ø40 - Ø50 - Ø63 - Ø90 - Ø125 mm
Actuator material	304 stainless steel / aluminium (only for Ø125 mm)
Piston material	aluminium
Piston seal material	FKM
Piloting fluid	air or inert gases
Piloting pressure	10 bar max.
Actuator position	360° rotatable

**CODING EXAMPLE**

<b>AS</b>	<b>X</b>	<b>2</b>	<b>1</b>	<b>-</b>	<b>W</b>	<b>015</b>	<b>G1</b>	<b>-</b>	<b>040</b>	<b>1</b>	<b>2</b>	<b>-</b>	
-----------	----------	----------	----------	----------	----------	------------	-----------	----------	------------	----------	----------	----------	--

<b>AS</b>	SERIES
<b>X</b>	TYPE OF ACTUATOR X = metal actuator
<b>2</b>	BODY MATERIAL 1 = 304 stainless steel (DN 100) 2 = 316 stainless steel (DN8 ÷ DN80)
<b>1</b>	NUMBER OF WAYS - FUNCTIONS 0 = 2/2-way NO 1 = 2/2-way NC 3 = 2/2-way DA (Double Acting)
<b>W</b>	FLOW DIRECTION W = under the seat (anti-water hammer) Y = above the seat
<b>015</b>	NOMINAL DIAMETER 008 = DN 8 010 = DN 10 015 = DN 15 020 = DN 20 025 = DN 25 032 = DN 32 040 = DN 40 050 = DN 50 065 = DN 65 080 = DN 80 100 = DN 100 - only for flanged version with NC and DA function and pressure under the seat
<b>G1</b>	BODY CONNECTION G1 = BSP thread DIN 228-1 T1 = BSPT thread DIN 2999-1 N1 = NPT thread ASME B1.20.1 H7 = welding ends DIN 11850-2 / DIN 11866-A H8 = welding ends DIN 11850-3 K7 = tri-clamp ISO 2852 F2 = flange DIN 2543
<b>040</b>	ACTUATOR DIMENSION 040 = Ø40 mm 050 = Ø50 mm 063 = Ø63 mm 090 = Ø90 mm 125 = Ø125 mm
<b>1</b>	ACTUATOR MATERIAL 1 = 304 stainless steel 8 = aluminium
<b>2</b>	SEALS 2 = for standard temperatures -10 ÷ 180 °C 3 = for high temperatures 25 ÷ 220 °C
	<p>OPTIONS</p> <p>= none</p> <p>PS1 = NPN type proximity switch - NO contact - 10 ÷ 30 V DC power supply</p> <p>PS2 = NPN type proximity switch - NC contact - 10 ÷ 30 V DC power supply</p> <p>PS3 = PNP type proximity switch - NO contact - 10 ÷ 30 V DC power supply</p> <p>PS4 = PNP type proximity switch - NC contact - 10 ÷ 30 V DC power supply</p> <p>PS5 = SCR type proximity switch - NO contact - 20 ÷ 250 V AC power supply</p> <p>PS6 = SCR type proximity switch - NC contact - 20 ÷ 250 V AC power supply</p> <p>SL1 = stroke limiter for Ø50 - Ø63 mm actuators</p> <p>SL2 = stroke limiter for Ø90 mm actuators</p> <p>PI1 = position indicator for Ø40 - Ø50 - Ø63 - Ø90 mm actuators</p> <p>PI2 = position indicator for Ø125 mm actuators</p>

**Series ASX angle seat valve - 2/2-way NC - pressure under the seat**



The valves with flow direction under the seat are suitable for incompressible fluids. This function prevents the hydraulic water hammer effect.

**NOTE TO THE TABLE:**

The indicated models are suitable for operating temperatures from -10 to +180 °C. For higher temperatures, please see the CODING EXAMPLE.  
\* to complete the code add BODY CONNECTION.

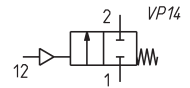

**DRAWING LEGEND:**  
C = valve in closed position  
O = valve in open position

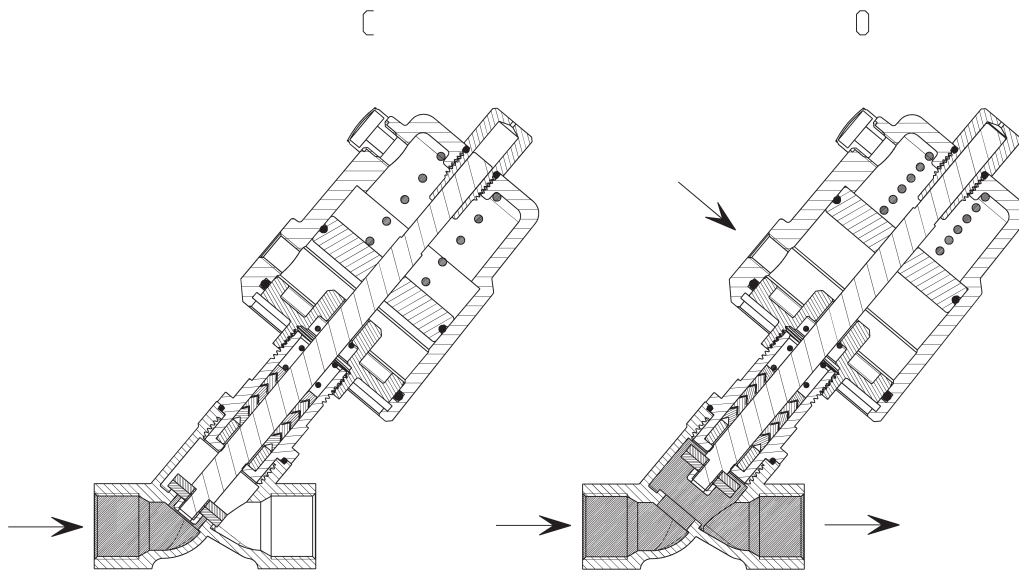

DIMENSIONS									
Mod.	Function	DN	Ports	Orifice Ø (mm)	Kv (m³/h)	Differential pressure min ÷ max (bar)	Minimum piloting pressure (bar)	Actuator Ø (mm)	Actuator material
ASX21-W008 <sup>2</sup> -04012	2/2 NC	8	1/4"	13	2.2	0 ÷ 13	≥ 4	40	304 stainless steel
ASX21-W008 <sup>2</sup> -05012	2/2 NC	8	1/4"	13	2.2	0 ÷ 14	≥ 4.5	50	304 stainless steel
ASX21-W010 <sup>2</sup> -04012	2/2 NC	10	3/8"	13	3.9	0 ÷ 13	≥ 4	40	304 stainless steel
ASX21-W010 <sup>2</sup> -05012	2/2 NC	10	3/8"	13	3.9	0 ÷ 14	≥ 4.5	50	304 stainless steel
ASX21-W015 <sup>2</sup> -04012	2/2 NC	15	1/2"	13	4.3	0 ÷ 13	≥ 4	40	304 stainless steel
ASX21-W015 <sup>2</sup> -05012	2/2 NC	15	1/2"	13	4.3	0 ÷ 14	≥ 4.5	50	304 stainless steel
ASX21-W020 <sup>2</sup> -05012	2/2 NC	20	3/4"	18	7.6	0 ÷ 14	≥ 4.5	50	304 stainless steel
ASX21-W025 <sup>2</sup> -05012	2/2 NC	25	1"	24	15.8	0 ÷ 8	≥ 4.5	50	304 stainless steel
ASX21-W025 <sup>2</sup> -06312	2/2 NC	25	1"	24	15.8	0 ÷ 13	≥ 5	63	304 stainless steel
ASX21-W032 <sup>2</sup> -06312	2/2 NC	32	1 1/4"	31	26	0 ÷ 6	≥ 5	63	304 stainless steel
ASX21-W032 <sup>2</sup> -09012	2/2 NC	32	1 1/4"	31	26	0 ÷ 16	≥ 6	90	304 stainless steel
ASX21-W040 <sup>2</sup> -06312	2/2 NC	40	1 1/2"	35	32	0 ÷ 5	≥ 5	63	304 stainless steel
ASX21-W040 <sup>2</sup> -09012	2/2 NC	40	1 1/2"	35	32	0 ÷ 16	≥ 6	90	304 stainless steel
ASX21-W050 <sup>2</sup> -06312	2/2 NC	50	2"	45	52	0 ÷ 5	≥ 5	63	304 stainless steel
ASX21-W050 <sup>2</sup> -09012	2/2 NC	50	2"	45	52	0 ÷ 10	≥ 6	90	304 stainless steel
ASX21-W050 <sup>2</sup> -12582	2/2 NC	50	2"	45	52	0 ÷ 16	≥ 5.5	125	aluminium
ASX21-W065 <sup>2</sup> -09012	2/2 NC	65	2 1/2"	61	83.2	0 ÷ 5	≥ 6	90	304 stainless steel
ASX21-W065 <sup>2</sup> -12582	2/2 NC	65	2 1/2"	61	83.2	0 ÷ 9	≥ 5.5	125	aluminium
ASX21-W080 <sup>2</sup> -12582	2/2 NC	80	3"	80	119	0 ÷ 5	≥ 5.5	125	aluminium
ASX11-W100F2-12582	2/2 NC	100	4"	90	132	0 ÷ 2.5	≥ 5.5	125	aluminium

**Series ASX angle seat valve - 2/2-way NC - pressure above the seat**

The valves with flow direction above the seat are suitable for compressible fluids.



**NOTE TO THE TABLE:**  
The indicated models are suitable for operating temperatures from -10 to +180 °C. For higher temperatures, please see the CODING EXAMPLE.  
\* to complete the code add BODY CONNECTION.

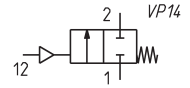

**DRAWING LEGEND:**  
C = valve in closed position  
O = valve in open position

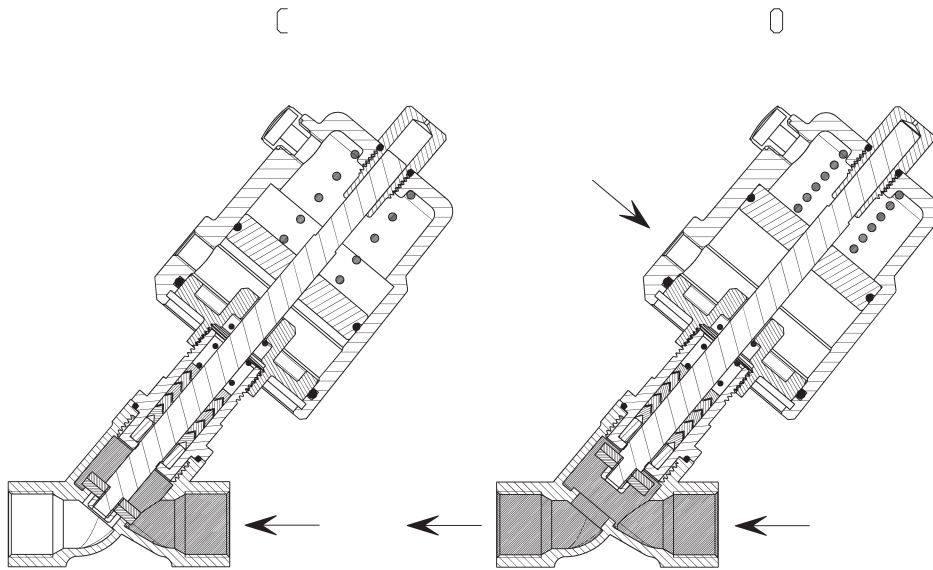

DIMENSIONS									
Mod.	Function	DN	Ports	Orifice Ø (mm)	Kv (m³/h)	Differential pressure min + max (bar)	Minimum piloting pressure (bar)	Actuator Ø (mm)	Actuator material
ASX21-Y008*-04012	2/2 NC	8	1/4"	13	2.2	0 ÷ 16	3 ÷ 4.5	40	304 stainless steel
ASX21-Y008*-05012	2/2 NC	8	1/4"	13	2.2	0 ÷ 16	3 ÷ 3.5	50	304 stainless steel
ASX21-Y010*-04012	2/2 NC	10	3/8"	13	3.9	0 ÷ 16	3 ÷ 4.5	40	304 stainless steel
ASX21-Y010*-05012	2/2 NC	10	3/8"	13	3.9	0 ÷ 16	3 ÷ 3.5	50	304 stainless steel
ASX21-Y015*-04012	2/2 NC	15	1/2"	13	4.3	0 ÷ 16	3 ÷ 4.5	40	304 stainless steel
ASX21-Y015*-05012	2/2 NC	15	1/2"	13	4.3	0 ÷ 16	3 ÷ 3.5	50	304 stainless steel
ASX21-Y020*-05012	2/2 NC	20	3/4"	18	7.6	0 ÷ 16	3 ÷ 4	50	304 stainless steel
ASX21-Y025*-05012	2/2 NC	25	1"	24	15.8	0 ÷ 16	3 ÷ 4.5	50	304 stainless steel
ASX21-Y025*-06312	2/2 NC	25	1"	24	15.8	0 ÷ 16	3 ÷ 3.5	63	304 stainless steel
ASX21-Y032*-06312	2/2 NC	32	1 1/4"	31	26	0 ÷ 16	3 ÷ 5.5	63	304 stainless steel
ASX21-Y032*-09012	2/2 NC	32	1 1/4"	31	26	0 ÷ 16	3 ÷ 3.5	90	304 stainless steel
ASX21-Y040*-06312	2/2 NC	40	1 1/2"	35	32	0 ÷ 16	3 ÷ 6.5	63	304 stainless steel
ASX21-Y040*-09012	2/2 NC	40	1 1/2"	35	32	0 ÷ 16	3 ÷ 4	90	304 stainless steel
ASX21-Y050*-06312	2/2 NC	50	2"	45	52	0 ÷ 9	3 ÷ 7	63	304 stainless steel
ASX21-Y050*-09012	2/2 NC	50	2"	45	52	0 ÷ 16	3 ÷ 4.5	90	304 stainless steel
ASX21-Y050*-12582	2/2 NC	50	2"	45	52	0 ÷ 16	3 ÷ 4	125	aluminium
ASX21-Y065*-09012	2/2 NC	65	2 1/2"	61	83.2	0 ÷ 10	3 ÷ 6	90	304 stainless steel
ASX21-Y065*-12582	2/2 NC	65	2 1/2"	61	83.2	0 ÷ 16	3 ÷ 4	125	aluminium
ASX21-Y080*-12582	2/2 NC	80	3"	80	119	0 ÷ 12	3 ÷ 7	125	aluminium

**Series ASX angle seat valve - 2/2-way NO - pressure under the seat**



The valves with flow direction under the seat are suitable for incompressible fluids. This function prevents the hydraulic water hammer effect.

**NOTE TO THE TABLE:**

The indicated models are suitable for operating temperatures from -10 to +180 °C. For higher temperatures, please see the CODING EXAMPLE.  
\* to complete the code add BODY CONNECTION.

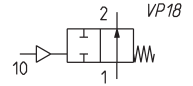

**DRAWING LEGEND:**  
C = valve in closed position  
O = valve in open position

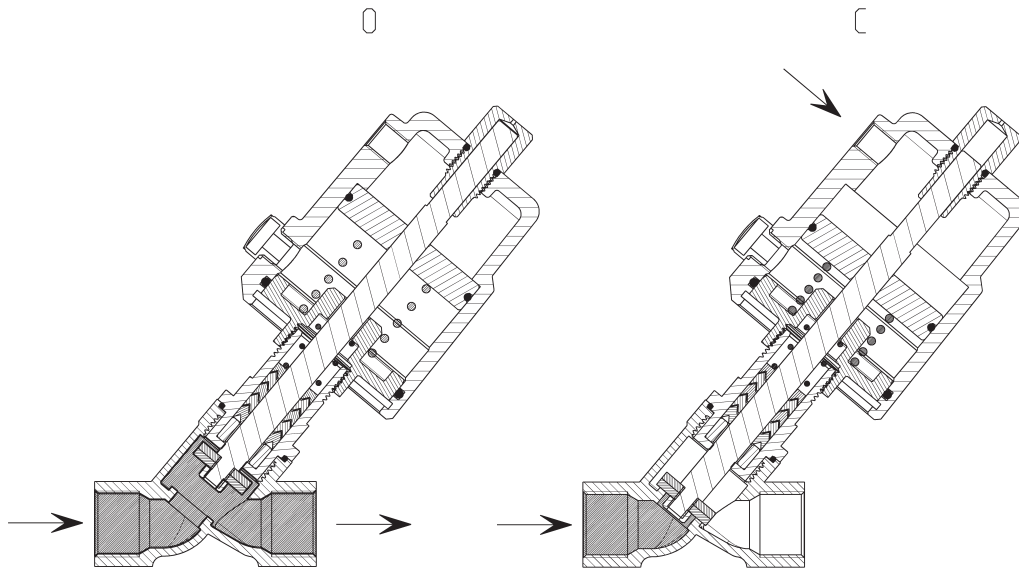

DIMENSIONS									
Mod.	Function	DN	Ports	Orifice Ø (mm)	Kv (m <sup>3</sup> /h)	Differential pressure min ÷ max (bar)	Minimum piloting pressure (bar)	Actuator Ø (mm)	Actuator material
ASX20-W008 <sup>2</sup> -04012	2/2 NO	8	1/4"	13	2.2	0 ÷ 16	3 ÷ 5	40	304 stainless steel
ASX20-W008 <sup>2</sup> -05012	2/2 NO	8	1/4"	13	2.2	0 ÷ 16	3 ÷ 4	50	304 stainless steel
ASX20-W010 <sup>2</sup> -04012	2/2 NO	10	3/8"	13	3.9	0 ÷ 16	3 ÷ 5	40	304 stainless steel
ASX20-W010 <sup>2</sup> -05012	2/2 NO	10	3/8"	13	3.9	0 ÷ 16	3 ÷ 4	50	304 stainless steel
ASX20-W015 <sup>2</sup> -04012	2/2 NO	15	1/2"	13	4.3	0 ÷ 16	3 ÷ 5	40	304 stainless steel
ASX20-W015 <sup>2</sup> -05012	2/2 NO	15	1/2"	13	4.3	0 ÷ 16	3 ÷ 4	50	304 stainless steel
ASX20-W020 <sup>2</sup> -05012	2/2 NO	20	3/4"	18	7.6	0 ÷ 16	3 ÷ 6	50	304 stainless steel
ASX20-W025 <sup>2</sup> -05012	2/2 NO	25	1"	24	15.8	0 ÷ 13	3 ÷ 6	50	304 stainless steel
ASX20-W025 <sup>2</sup> -06312	2/2 NO	25	1"	24	15.8	0 ÷ 16	3 ÷ 5	63	304 stainless steel
ASX20-W032 <sup>2</sup> -06312	2/2 NO	32	1 1/4"	31	26	0 ÷ 13	3 ÷ 6	63	304 stainless steel
ASX20-W040 <sup>2</sup> -06312	2/2 NO	40	1 1/2"	35	32	0 ÷ 7	3 ÷ 6	63	304 stainless steel
ASX20-W040 <sup>2</sup> -09012	2/2 NO	40	1 1/2"	35	32	0 ÷ 16	3 ÷ 3.5	90	304 stainless steel
ASX20-W050 <sup>2</sup> -06312	2/2 NO	50	2"	45	52	0 ÷ 5	3 ÷ 6	63	304 stainless steel
ASX20-W050 <sup>2</sup> -09012	2/2 NO	50	2"	45	52	0 ÷ 12	3 ÷ 6	90	304 stainless steel
ASX20-W065 <sup>2</sup> -09012	2/2 NO	65	2 1/2"	61	83.2	0 ÷ 7.5	3 ÷ 5	90	304 stainless steel
ASX20-W065 <sup>2</sup> -12582	2/2 NO	65	2 1/2"	61	83.2	0 ÷ 14	3 ÷ 7	125	aluminium
ASX20-W080 <sup>2</sup> -12582	2/2 NO	80	3"	80	119	0 ÷ 12	3 ÷ 7	125	aluminium

**Series ASX angle seat valve - 2/2-way NO - pressure above the seat**

The valves with flow direction above the seat are suitable for compressible fluids.



**NOTE TO THE TABLE:**  
The indicated models are suitable for operating temperatures from -10 to +180 °C. For higher temperatures, please see the CODING EXAMPLE.  
\* to complete the code add BODY CONNECTION.

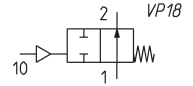

**DRAWING LEGEND:**  
C = valve in closed position  
O = valve in open position

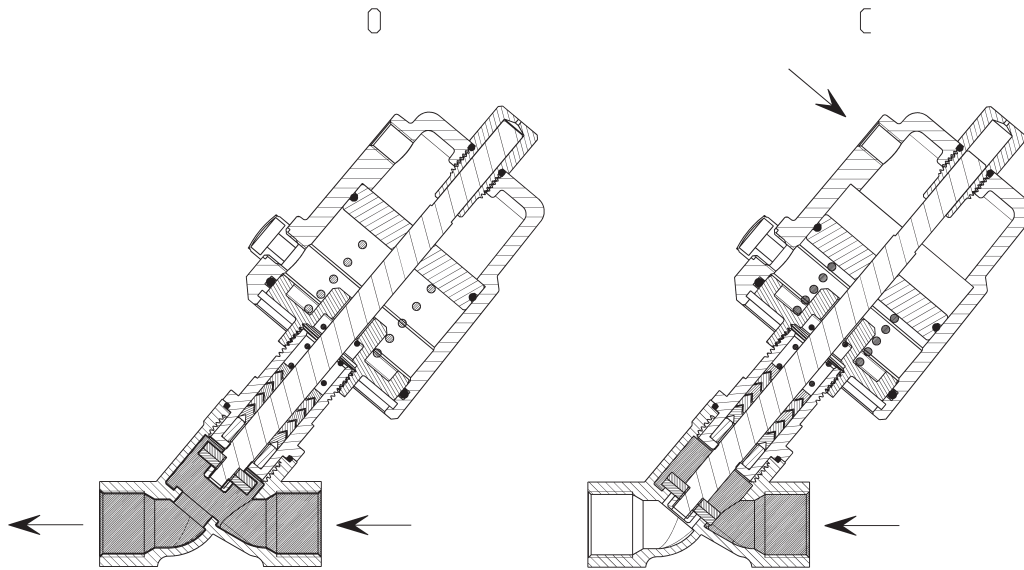

DIMENSIONS									
Mod.	Function	DN	Ports	Orifice Ø (mm)	Kv (m³/h)	Differential pressure min ÷ max (bar)	Minimum piloting pressure (bar)	Actuator Ø (mm)	Actuator material
ASX20-Y008*-04012	2/2 NO	8	1/4"	13	2.2	0 ÷ 16	≥ 3	40	304 stainless steel
ASX20-Y008*-05012	2/2 NO	8	1/4"	13	2.2	0 ÷ 16	≥ 3	50	304 stainless steel
ASX20-Y010*-04012	2/2 NO	10	3/8"	13	3.9	0 ÷ 16	≥ 3	40	304 stainless steel
ASX20-Y010*-05012	2/2 NO	10	3/8"	13	3.9	0 ÷ 16	≥ 3	50	304 stainless steel
ASX20-Y015*-04012	2/2 NO	15	1/2"	13	4.3	0 ÷ 16	≥ 3	40	304 stainless steel
ASX20-Y015*-05012	2/2 NO	15	1/2"	13	4.3	0 ÷ 16	≥ 3	50	304 stainless steel
ASX20-Y020*-05012	2/2 NO	20	3/4"	18	7.6	0 ÷ 12	≥ 3	50	304 stainless steel
ASX20-Y025*-05012	2/2 NO	25	1"	24	15.8	0 ÷ 3	≥ 3	50	304 stainless steel
ASX20-Y025*-06312	2/2 NO	25	1"	24	15.8	0 ÷ 16	≥ 4.5	63	304 stainless steel
ASX20-Y032*-06312	2/2 NO	32	1 1/4"	31	26	0 ÷ 14	≥ 4.5	63	304 stainless steel
ASX20-Y040*-06312	2/2 NO	40	1 1/2"	35	32	0 ÷ 14	≥ 4.5	63	304 stainless steel
ASX20-Y050*-06312	2/2 NO	50	2"	45	52	0 ÷ 6	≥ 4.5	63	304 stainless steel

**Series ASX angle seat valve - 2/2-way DA - pressure under the seat**



The valves with flow direction under the seat are suitable for incompressible fluids. This function prevents the hydraulic water hammer effect.

**NOTE TO THE TABLE:**

The indicated models are suitable for operating temperatures from -10 to +180 °C. For higher temperatures, please see the CODING EXAMPLE.  
\* to complete the code add BODY CONNECTION.

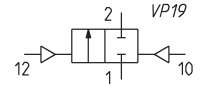

**DRAWING LEGEND:**  
C = valve in closed position  
O = valve in open position

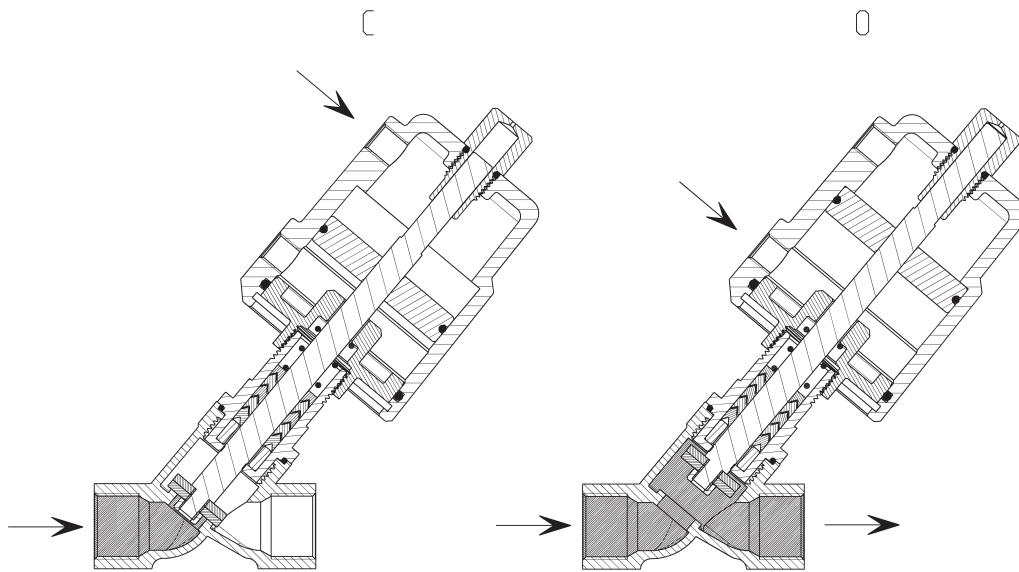

DIMENSIONS									
Mod.	Function	DN	Ports	Orifice Ø (mm)	Kv (m³/h)	Differential pressure min ÷ max (bar)	Minimum piloting pressure (bar)	Actuator Ø (mm)	Actuator material
ASX23-W008 <sup>2</sup> -04012	2/2 DA	8	1/4"	13	2.2	0 ÷ 16	3 ÷ 4	40	304 stainless steel
ASX23-W008 <sup>2</sup> -05012	2/2 DA	8	1/4"	13	2.2	0 ÷ 16	3 ÷ 4	50	304 stainless steel
ASX23-W010 <sup>2</sup> -04012	2/2 DA	10	3/8"	13	3.9	0 ÷ 16	3 ÷ 4	40	304 stainless steel
ASX23-W010 <sup>2</sup> -05012	2/2 DA	10	3/8"	13	3.9	0 ÷ 16	3 ÷ 4	50	304 stainless steel
ASX23-W015 <sup>2</sup> -04012	2/2 DA	15	1/2"	13	4.3	0 ÷ 16	3 ÷ 4	40	304 stainless steel
ASX23-W015 <sup>2</sup> -05012	2/2 DA	15	1/2"	13	4.3	0 ÷ 16	3 ÷ 4	50	304 stainless steel
ASX23-W020 <sup>2</sup> -05012	2/2 DA	20	3/4"	18	7.6	0 ÷ 16	3 ÷ 4	50	304 stainless steel
ASX23-W025 <sup>2</sup> -05012	2/2 DA	25	1"	24	15.8	0 ÷ 16	3 ÷ 6.5	50	304 stainless steel
ASX23-W025 <sup>2</sup> -06312	2/2 DA	25	1"	24	15.8	0 ÷ 16	3 ÷ 5.5	63	304 stainless steel
ASX23-W032 <sup>2</sup> -06312	2/2 DA	32	1 1/4"	31	26	0 ÷ 16	3 ÷ 7	63	304 stainless steel
ASX23-W032 <sup>2</sup> -09012	2/2 DA	32	1 1/4"	31	26	0 ÷ 16	3 ÷ 4.5	90	304 stainless steel
ASX23-W040 <sup>2</sup> -06312	2/2 DA	40	1 1/2"	35	32	0 ÷ 12	3 ÷ 7.5	63	304 stainless steel
ASX23-W040 <sup>2</sup> -09012	2/2 DA	40	1 1/2"	35	32	0 ÷ 16	3 ÷ 5	90	304 stainless steel
ASX23-W050 <sup>2</sup> -06312	2/2 DA	50	2"	45	52	0 ÷ 4	3 ÷ 7.5	63	304 stainless steel
ASX23-W050 <sup>2</sup> -09012	2/2 DA	50	2"	45	52	0 ÷ 16	3 ÷ 6	90	304 stainless steel
ASX23-W050 <sup>2</sup> -12582	2/2 DA	50	2"	45	52	0 ÷ 16	3 ÷ 4	125	aluminium
ASX23-W065 <sup>2</sup> -09012	2/2 DA	65	2 1/2"	61	83.2	0 ÷ 10	3 ÷ 7.5	90	304 stainless steel
ASX23-W065 <sup>2</sup> -12582	2/2 DA	65	2 1/2"	61	83.2	0 ÷ 16	3 ÷ 6	125	aluminium
ASX23-W080 <sup>2</sup> -12582	2/2 DA	80	3"	80	119	0 ÷ 10	3 ÷ 7	125	aluminium
ASX13-W100F2-12582	2/2 DA	100	4"	90	132	0 ÷ 8	3 ÷ 7.5	125	aluminium



**Series ASX angle seat valve - 2/2-way DA - pressure above the seat**

The valves with flow direction above the seat are suitable for compressible fluids.



**NOTE TO THE TABLE:**  
The indicated models are suitable for operating temperatures from -10 to +180 °C. For higher temperatures, please see the CODING EXAMPLE.  
\* to complete the code add BODY CONNECTION.

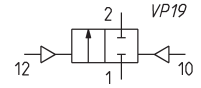

**DRAWING LEGEND:**  
C = valve in closed position  
O = valve in open position

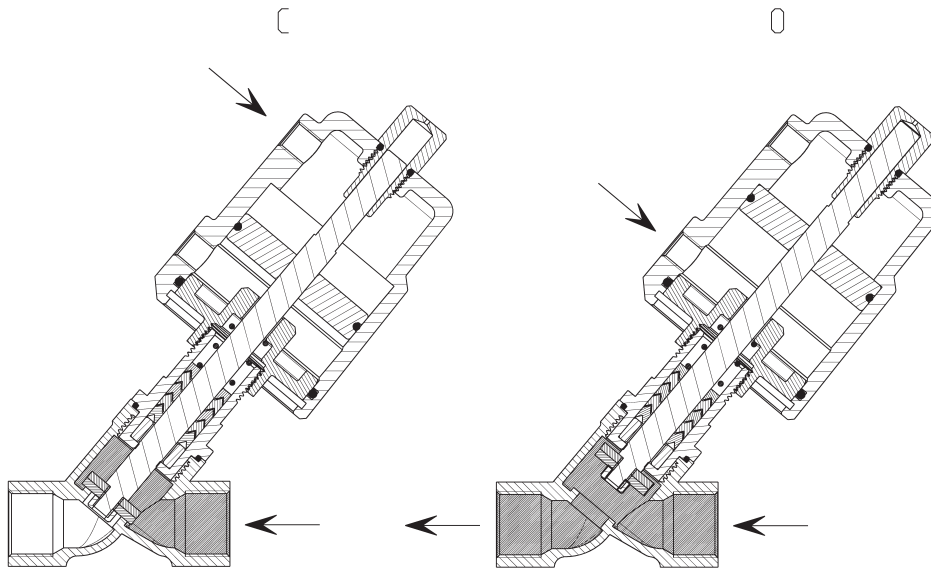

DIMENSIONS									
Mod.	Function	DN	Ports	Orifice Ø (mm)	Kv (m³/h)	Differential pressure min + max (bar)	Minimum piloting pressure (bar)	Actuator Ø (mm)	Actuator material
ASX23-Y008*-04012	2/2 DA	8	1/4"	13	2.2	0 ÷ 16	3 ÷ 4.5	40	304 stainless steel
ASX23-Y008*-05012	2/2 DA	8	1/4"	13	2.2	0 ÷ 16	3 ÷ 3.5	50	304 stainless steel
ASX23-Y010*-04012	2/2 DA	10	3/8"	13	3.9	0 ÷ 16	3 ÷ 4.5	40	304 stainless steel
ASX23-Y010*-05012	2/2 DA	10	3/8"	13	3.9	0 ÷ 16	3 ÷ 3.5	50	304 stainless steel
ASX23-Y015*-04012	2/2 DA	15	1/2"	13	4.3	0 ÷ 16	3 ÷ 4.5	40	304 stainless steel
ASX23-Y015*-05012	2/2 DA	15	1/2"	13	4.3	0 ÷ 16	3 ÷ 3.5	50	304 stainless steel
ASX23-Y020*-05012	2/2 DA	20	3/4"	18	7.6	0 ÷ 16	3 ÷ 4	50	304 stainless steel
ASX23-Y025*-05012	2/2 DA	25	1"	24	15.8	0 ÷ 16	3 ÷ 4.5	50	304 stainless steel
ASX23-Y025*-06312	2/2 DA	25	1"	24	15.8	0 ÷ 16	3 ÷ 3.5	63	304 stainless steel
ASX23-Y032*-06312	2/2 DA	32	1 1/4"	31	26	0 ÷ 16	3 ÷ 5.5	63	304 stainless steel
ASX23-Y032*-09012	2/2 DA	32	1 1/4"	31	26	0 ÷ 16	3 ÷ 4	90	304 stainless steel
ASX23-Y040*-06312	2/2 DA	40	1 1/2"	35	32	0 ÷ 16	3 ÷ 6.5	63	304 stainless steel
ASX23-Y040*-09012	2/2 DA	40	1 1/2"	35	32	0 ÷ 16	3 ÷ 4	90	304 stainless steel
ASX23-Y050*-06312	2/2 DA	50	2"	45	52	0 ÷ 10	3 ÷ 7	63	304 stainless steel
ASX23-Y050*-09012	2/2 DA	50	2"	45	52	0 ÷ 16	3 ÷ 4.5	90	304 stainless steel
ASX23-Y050*-12582	2/2 DA	50	2"	45	52	0 ÷ 16	3 ÷ 4	125	aluminium
ASX23-Y065*-09012	2/2 DA	65	2 1/2"	61	83.2	0 ÷ 10	3 ÷ 6	90	304 stainless steel
ASX23-Y065*-12582	2/2 DA	65	2 1/2"	61	83.2	0 ÷ 16	3 ÷ 4	125	aluminium
ASX23-Y080*-12582	2/2 DA	80	3"	80	119	0 ÷ 12	3 ÷ 7	125	aluminium



**Series ASX angle seat valve - dimensions and weight - threaded version**

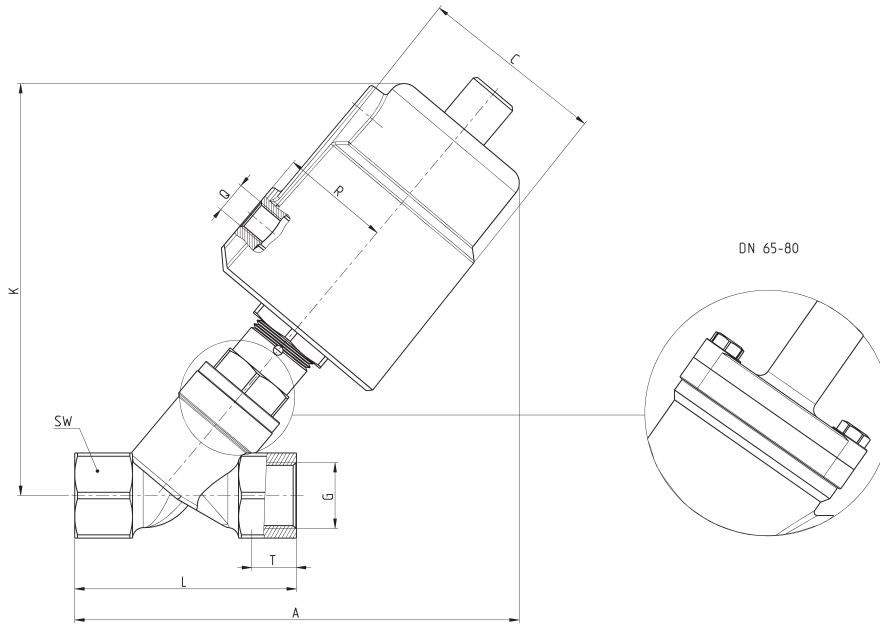

DIMENSIONS											WEIGHT	
DN	Actuator Ø (mm)	G	T	A	L	SW	C	R	K	Q	Below seat (Kgs)	Above seat (Kgs)
8	40	1/4"	12	124	68	27	50.5	27	112	1/8"	0.9	0.9
8	50	1/4"	12	135	68	27	60	33	125	1/8"	1.1	1.1
10	40	3/8"	12	124	68	27	50.5	27	112	1/8"	0.9	0.9
10	50	3/8"	12	135	68	27	60	33	125	1/8"	1.1	1.1
15	40	1/2"	15	124	68	27	50.5	27	112	1/8"	0.9	0.9
15	50	1/2"	15	135	68	27	60	33	125	1/8"	1.1	1.1
20	50	3/4"	16	140	75	32	60	33	132	1/8"	1.2	1.2
25	50	1"	17	150	90	40	60	33	136	1/8"	1.5	1.5
25	63	1"	17	172	90	40	75	41	162	1/8"	2.2	2.1
32	63	1 1/4"	21	190	116	50	75	41	174	1/8"	2.8	2.7
32	90	1 1/4"	21	235	116	50	106	55	223	1/8"	5.0	4.3
40	63	1 1/2"	21	190	116	56	75	41	175	1/8"	2.8	2.8
40	90	1 1/2"	21	235	116	56	106	55	223	1/8"	5.2	4.5
50	63	2"	22	205	138	69	75	41	183	1/8"	3.5	3.5
50	90	2"	22	250	138	69	106	55	232	1/8"	6.1	5.4
50	125	2"	22	305	138	69	170	85	300	1/4"	6.8	6.5
65	90	2 1/2"	26	275	178	85	106	55	280	1/8"	8.5	8.0
65	125	2 1/2"	26	320	178	85	170	85	330	1/4"	10.7	-
80	125	3"	27	340	210	100	170	85	355	1/4"	14.1	-

**Series ASX angle seat valve - dimensions and weight - welding ends version**



SERIES ASX ANGLE SEAT VALVES

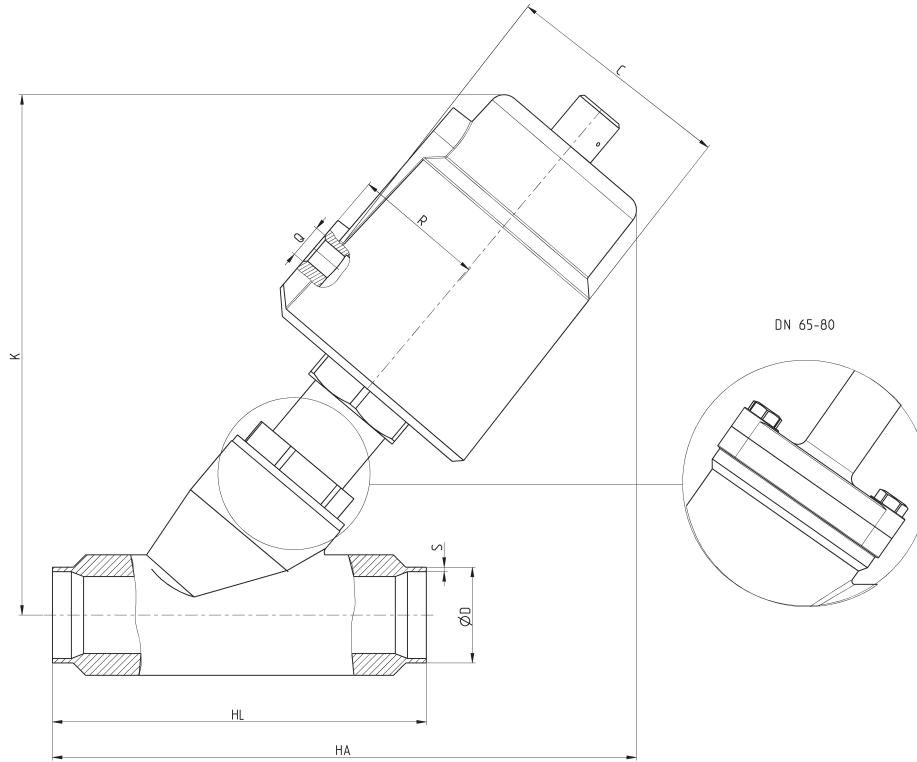

DIMENSIONS												WEIGHT	
DN	Actuator Ø (mm)	DIN11850-2 ØD	DIN11850-2 S	DIN11850-3 ØD	DIN11850-3 S	HA	HL	C	R	K	Q	Below seat (Kgs)	Above seat (Kgs)
15	40	19	1.5	20	2	118	70	50.5	27	112	1/8"	0.9	0.9
15	50	19	1.5	20	2	128	70	60	33	125	1/8"	1.1	1.1
20	50	23	1.5	24	2	135	82	60	33	132	1/8"	1.2	1.2
25	50	29	1.5	30	2	150	100	60	33	136	1/8"	1.5	1.5
25	63	29	1.5	30	2	175	100	75	41	162	1/8"	2.2	2.1
32	63	35	1.5	36	2	186	125	75	41	174	1/8"	2.6	2.5
32	90	35	1.5	36	2	232	125	106	55	223	1/8"	4.9	4.2
40	63	41	1.5	42	2	190	130	75	41	175	1/8"	2.8	2.8
40	90	41	1.5	42	2	235	130	106	55	223	1/8"	5.1	4.4
50	63	53	1.5	54	2	206	155	75	41	183	1/8"	3.4	3.4
50	90	53	1.5	54	2	250	155	106	55	232	1/8"	6.0	5.3
50	125	53	1.5	54	2	307	155	170	85	300	1/4"	6.7	6.5
65	90	70	2	-	-	320	270	106	55	280	1/8"	8.8	12.9
65	125	70	2	-	-	360	270	170	85	330	1/4"	10.7	-
80	125	85	2	-	-	360	284	170	85	355	1/4"	14.0	-

**Series ASX angle seat valve - dimensions and weight - flanged version**

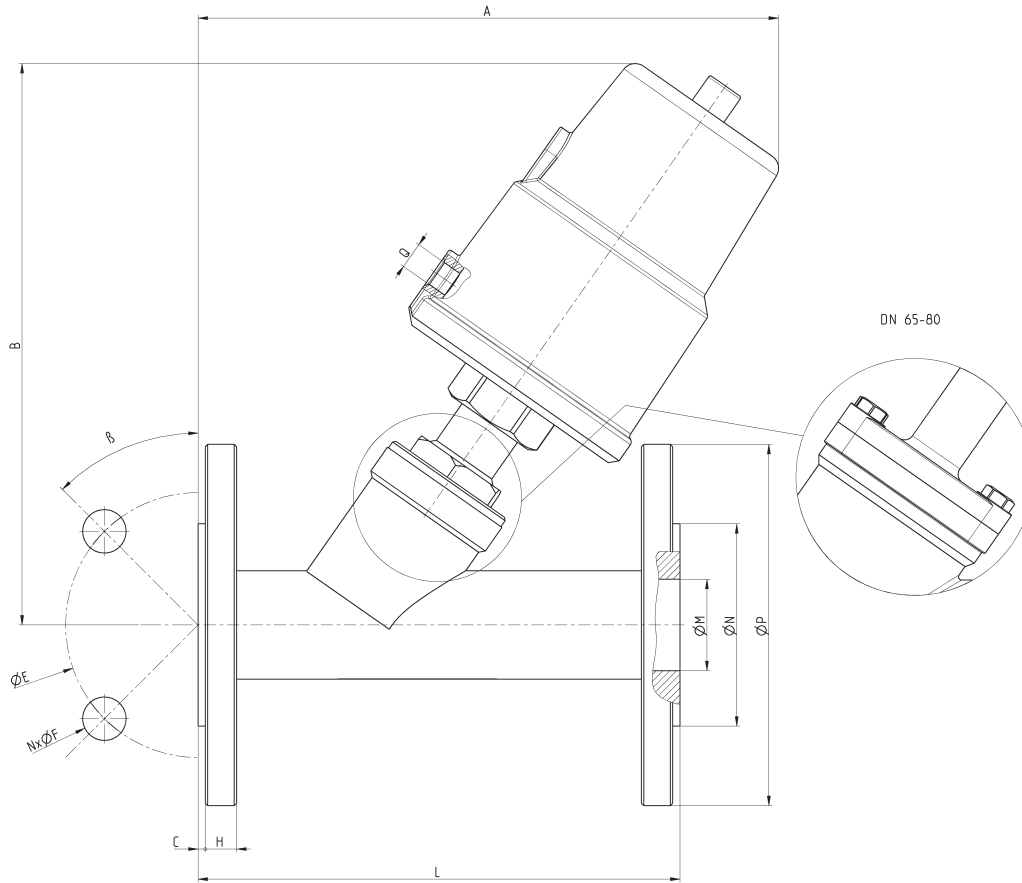

DIMENSIONS													WEIGHT		
DN	Actuator Ø (mm)	ØM	ØN	ØP	ØE	NxØF	β	A	B	L	C	H	Q	Below seat (Kgs)	Above seat (Kgs)
15	40	16	45	95	65	4x14	45°	135	125	130	2	14	1/8"	2.1	2.1
15	50	16	45	95	65	4x14	45°	145	140	130	2	14	1/8"	2.4	2.4
20	50	19	56	105	75	4x14	45°	165	140	150	2	14	1/8"	2.9	2.9
25	50	26	65	115	85	4x14	45°	170	145	160	2	14	1/8"	3.5	3.5
25	63	26	65	115	85	4x14	45°	190	175	160	2	14	1/8"	5.6	5.5
32	63	31	78	140	100	4x18	45°	190	188	180	2	16	1/8"	5.8	5.7
32	90	31	78	140	100	4x18	45°	230	235	180	2	16	1/8"	8.0	7.3
40	63	38	84	150	110	4x18	45°	206	190	200	3	16	1/8"	6.6	6.5
40	90	38	84	150	110	4x18	45°	250	240	200	3	16	1/8"	9.0	8.3
50	63	49	100	165	125	4x18	45°	235	195	230	3	16	1/8"	8.1	8.0
50	90	49	100	165	125	4x18	45°	277	245	230	3	16	1/8"	10.4	9.7
50	125	49	100	165	125	4x18	45°	330	310	230	3	16	1/4"	13.3	13.0
65	90	66	120	185	145	4x18	45°	330	280	290	3	18	1/8"	13.8	12.9
65	125	66	120	185	145	4x18	45°	375	330	290	3	18	1/4"	14.7	-
80	125	78	135	200	160	8x18	22.5°	380	355	310	3	20	1/4"	21.9	-
100	125	96	155	215	180	8x18	22.5°	420	395	350	3	20	1/4"	-	-

**Series ASX angle seat valve - dimensions and weight - tri-clamp version**



SERIES ASX ANGLE SEAT VALVES

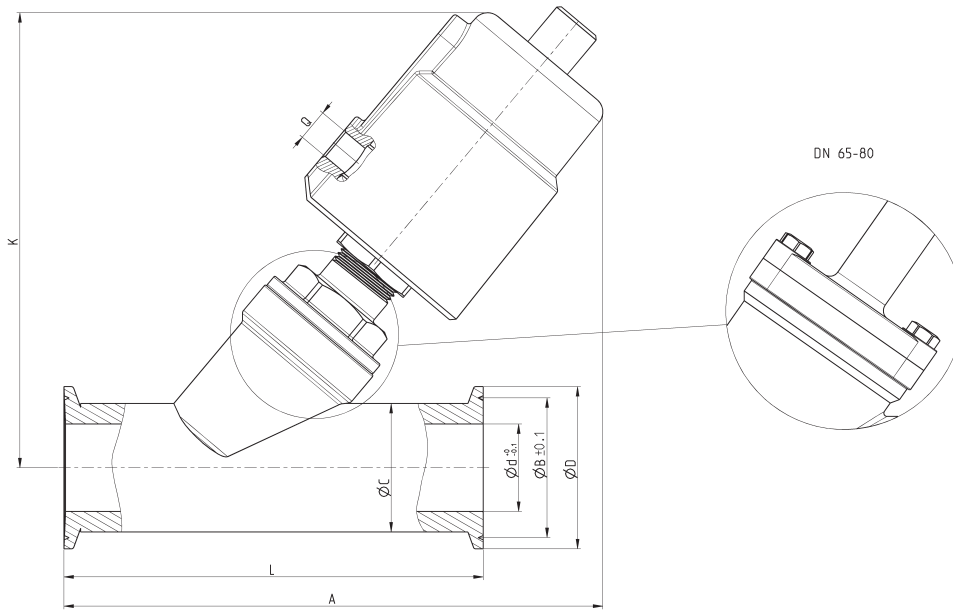

DIMENSIONS								WEIGHT			
DN	Actuator Ø (mm)	ØC	ØB	Ød	ØD	A	K	L	Q	Below seat (Kgs)	Above seat (Kgs)
15	40	19	27.5	15	34	130	115	80	1/8"	0.9	0.9
15	50	19	27.5	15	34	140	126	80	1/8"	1.1	1.1
20	50	25	43.5	19	50.5	158	148	130	1/8"	1.4	1.4
25	50	32	43.5	27	50.5	165	140	130	1/8"	1.6	1.6
25	63	32	43.5	27	50.5	188	166	130	1/8"	2.3	2.2
32	63	37	43.5	31	50.5	200	174	146	1/8"	2.7	2.6
32	90	37	43.5	31	50.5	245	223	146	1/8"	5.0	4.3
40	63	40	56.5	33	64	210	175	160	1/8"	3.0	2.9
40	90	40	56.5	33	64	255	223	160	1/8"	5.3	4.5
50	63	53	56.5	45	64	221	185	175	1/8"	3.4	2.4
50	90	53	56.5	45	64	265	235	175	1/8"	6.2	5.2
50	125	53	56.5	45	64	325	296	175	1/4"	7.0	6.7
65	90	75	83.5	66	91	325	280	278	1/8"	7.9	7.6
65	125	75	83.5	66	91	360	330	278	1/4"	11.3	-
80	125	89	97	78	106	360	352	290	1/4"	-	-

### Series ASX angle seat valve - options - proximity switch



Available on all models of angle seat valves to control the state of the open valve.  
 Type: NPN, NO or NC - PNP, NO or NC - SCR, NO or NC  
 Switching distance: 3 mm ± 10%  
 Operating temperature: -25 ÷ 70 °C  
 Body material: nickel-plated brass  
 Sensor material: ABS  
 Protection class: IP67

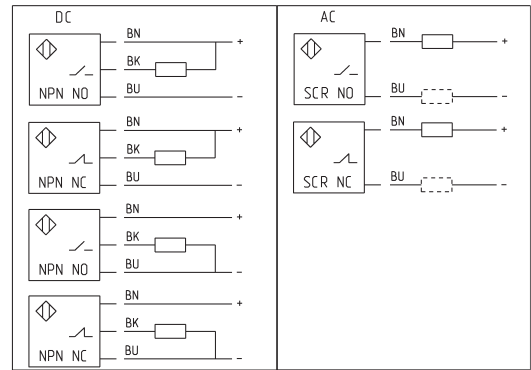

PS1	NPN type - NO contact - 10 ÷ 30 V DC power supply
PS2	NPN type - NC contact - 10 ÷ 30 V DC power supply
PS3	PNP type - NO contact - 10 ÷ 30 V DC power supply
PS4	PNP type - NC contact - 10 ÷ 30 V DC power supply
PS5	SCR type - NO contact - 20 ÷ 250 V AC power supply
PS6	SCR type - NC contact - 20 ÷ 250 V AC power supply

### Series ASX angle seat valve - options - position indicator



Available on all models of angle seat valves to control the state of the open and closed valve.  
 Type of limit switch: mechanical micro-switch  
 Operating voltage: 12 ÷ 36 V DC  
 Operating current: 25 mA / 24 V DC  
 Adjustment range: 5 ÷ 30 mm  
 Operating temperature: -30 ÷ 80 °C  
 Housing material: PA6/GF30 + PC  
 Protection class: IP65

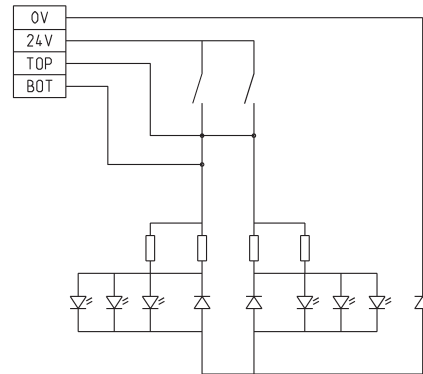

PI1	Position indicator for Ø40 - Ø50 - Ø63 - Ø90 mm actuators
PI2	Position indicator for Ø125 mm actuators

### Series ASX angle seat valve - options - stroke limiter



Available only for Ø50 - Ø63 - Ø90 mm actuators to limit the actuator's stroke from 0 to 100% in order to adjust the maximum flow.

SL1	Stroke limiter for Ø50 - Ø63 mm actuators
SL2	Stroke limiter for Ø90 mm actuators