

Parallel grippers with T-guide Series CGPT

Single and double acting, magnetic, self-centering
Sizes: 16, 20, 25, 32, 40, 50, 63, 80 mm



Thanks to the use of a high performing and precise force transmission system, the Series CGPT grippers are able to provide high gripping forces while guaranteeing a very high repeatability.

The wide range of sizes available allows you to find the best solution for any need of movement. The grippers are supplied with centering bushes (tolerance H8) which, once positioned on the body and/or on the jaws, are able to guarantee, during maintenance, a high interchangeability of the gripper and of the extensions.

- » Robust, compact and light design
- » High closing/opening forces
- » Fixing from the top, from below and from the side
- » Supply on the side or on the bottom (even without using tubes)
- » Self-centering jaws
- » High closing and opening repeatability
- » High interchangeability (centering bushes)
- » Position detection thanks to the use of magnetic proximity switches.
- » In compliance with ROHS directive
- » PTFE, Silicone and Copper free
- » High reliability
- » High resistance to external loads thanks to the T-guide
- » Variants available for use in ATEX zones and for high temperatures

GENERAL DATA

Type of construction	Self-centering parallel gripper with T-guide
Operation	Single acting (NO, NC), double acting
Sizes	16, 20, 25, 32, 40, 50, 63, 80 mm
Force transmission	Lever
Air connections	M3 (Ø16), M5 (Ø20, 25, 32), G1/8 (Ø40, 50, 63, 80)
Working pressure	2 ÷ 8 bar (double acting), 4 ÷ 8 bar (single acting)
Working temperature	5°C ÷ 60°C (standard) - 5°C ÷ 130°C (high temperature version)
Store temperature	-10°C ÷ 80°C
Maximum use frequency	3 Hz (Ø 16, 20, 25, 32), 2 Hz (Ø 40, 50, 63, 80)
Repeatability	0.02 mm
Interchangeability	0.1 mm
Medium	Filtered air in class 7.4.4 according to ISO 8573-1. In case lubricated air is used, we recommend ISOVG32 oil and to never interrupt lubrication.
Lubrication	After 10 million cycles, grease the sliding zones using Molykote DX grease.
Protection class	IP 40
Compatibility	ROHS Directive
Certifications	ATEX (II 2GD c IIC 120°C(T4)-20°C≤Ta≤80)
Materials	PTFE, Silicone and Copper free

N.B. Pressurize the pneumatic system gradually in order to avoid uncontrolled movements

CODING EXAMPLE

CGPT	-	16	-	NC	-	W	EX
-------------	----------	-----------	----------	-----------	----------	----------	-----------

CGPT	SERIES	
16	SIZES: 16 20 25 32 40 50 63 80	
NC	FUNCTIONING: = double acting NO = single acting, normally open NC = single acting, normally closed	PNEUMATIC SYMBOLS PNZ1 PNZ3 PNZ2
W	VERSION: = standard W = high temperatures (130 °C) - not magnetic	
EX	Add EX to order the certified ATEX version	

SERIES CGPT PARALLEL GRIPPERS WITH T-GUIDE

PNEUMATIC SYMBOLS

The pneumatic symbols which have been indicated in the CODING EXAMPLE are shown below.

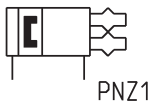

Series CGPT grippers - construction

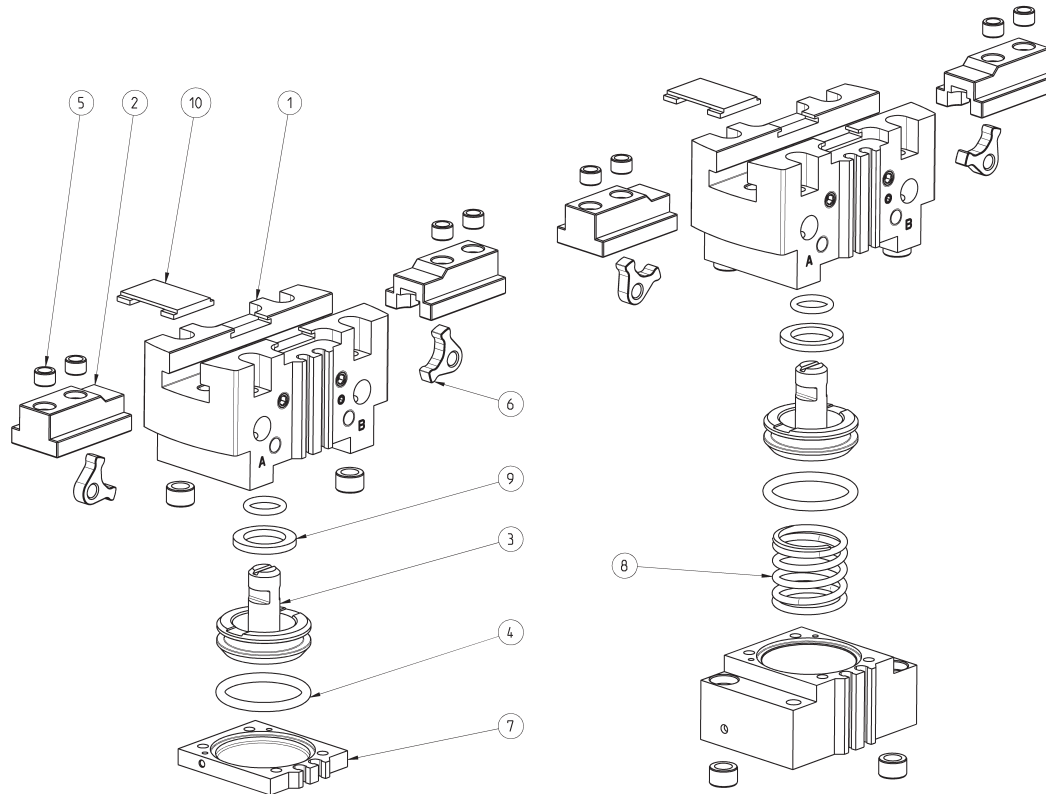

LIST OF COMPONENTS

PARTS	MATERIALS
1 - Body	Aluminium
2 - Guide	Stainless steel
3 - Cursor	Stainless steel
4 - Piston	HNBR / FKM
5 - Jaw	Stainless steel
6 - Cover	Steel
7 - Spring	Aluminium / Stainless steel
8 - Magnete	Stainless steel
9 - Screws	Neodymium
10 - Seals	Stainless steel

CGPT gripper, size 16 mm - dimensions



DRAWING LEGEND:
A = Opening of air connection
B = Closing of air connection
C = Closed gripper
D = Open gripper

SERIES CGPT PARALLEL GRIPPERS WITH T-GUIDE

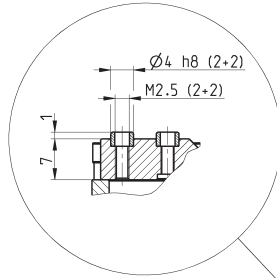
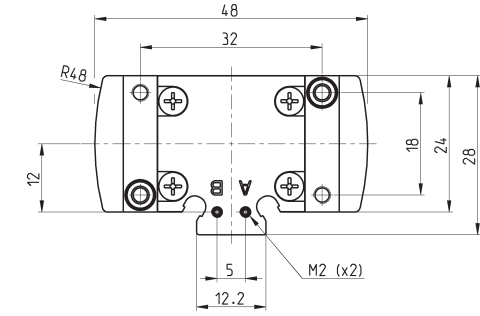

CGPT-16-NO
CGPT-16-NC

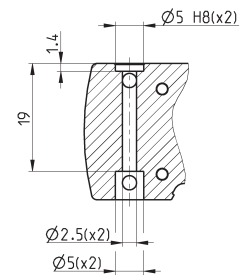
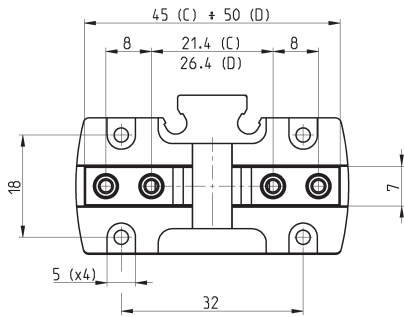
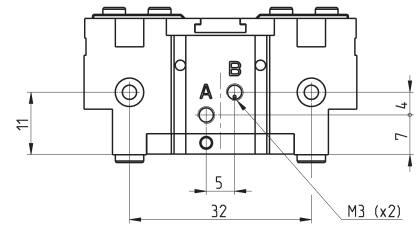
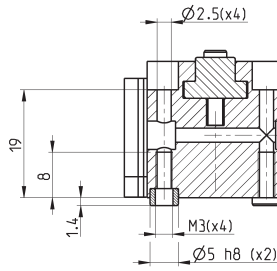
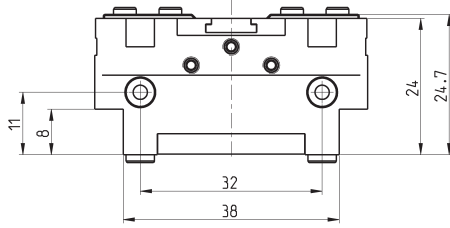
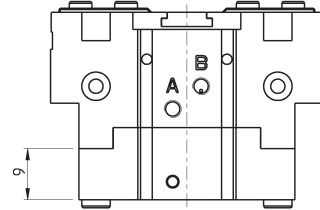

Mod.	Total closing gripping force at 6 bar (N)	Closing gripping force each jaw at 6 bar (N)	Total opening gripping force at 6 bar (N)	Opening gripping force each jaw at 6 bar (N)	Stroke per jaw (mm)	Working pressure (bar)	Working temperature (°C)	Repeatability (mm)	Max use frequency (Hz)	Weight (Kg)
CGPT-16	114	57	130	65	2.5	2 ÷ 8	5 ÷ 60	0.02	3	0.09
CGPT-16-NC	152	76	84	42	2.5	4 ÷ 8	5 ÷ 60	0.02	3	0.11
CGPT-16-NO	70	35	166	83	2.5	4 ÷ 8	5 ÷ 60	0.02	3	0.1

CGPT gripper, size 20 mm - dimensions



DRAWING LEGEND:

- A = Opening of air connection
- B = Closing of air connection
- C = Closed gripper
- D = Open gripper

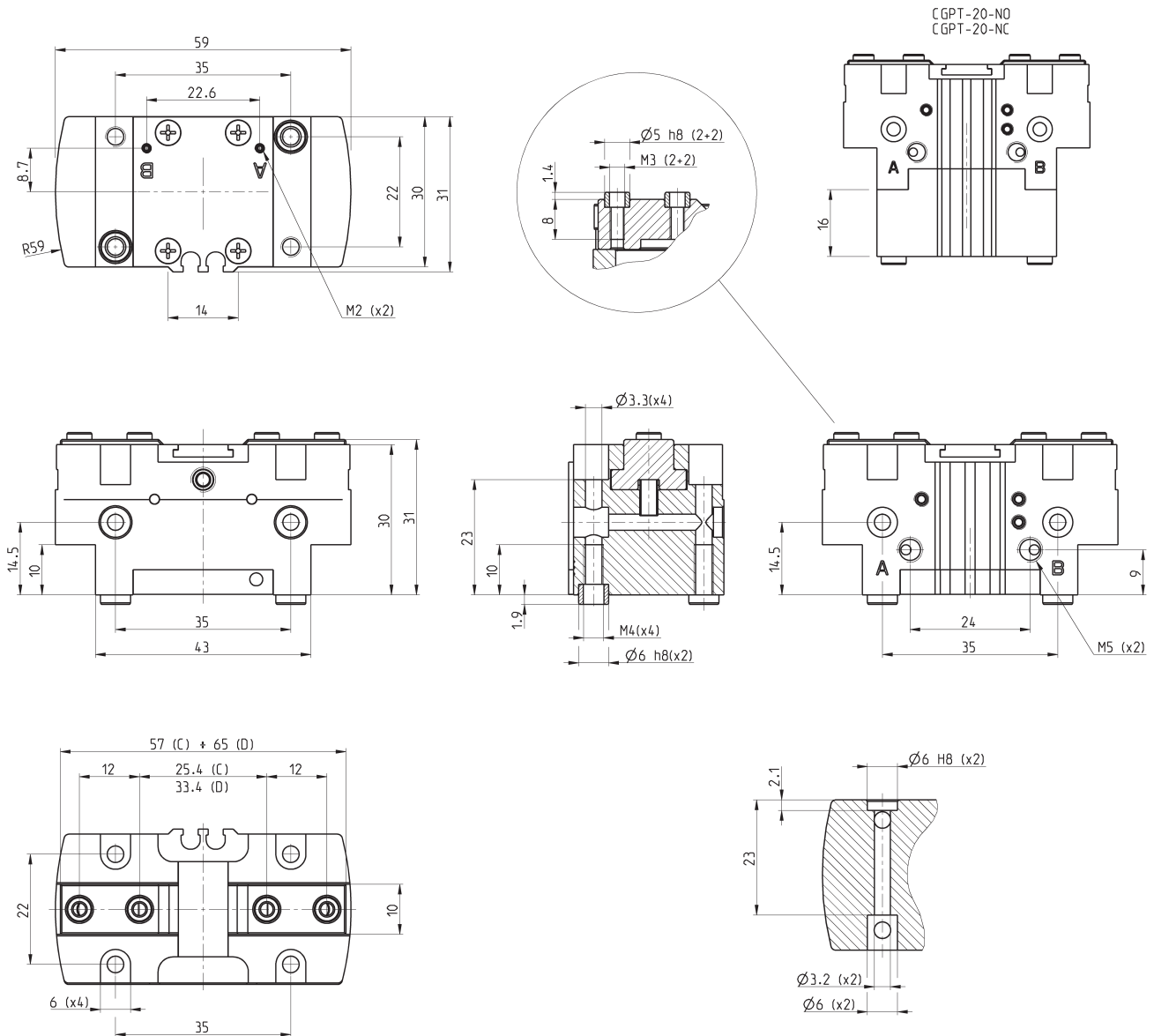

Mod.	Total closing gripping force at 6 bar (N)	Closing gripping force each jaw at 6 bar (N)	Total opening gripping force at 6 bar (N)	Opening gripping force each jaw at 6 bar (N)	Stroke per jaw (mm)	Working pressure (bar)	Working temperature (°C)	Repeatability (mm)	Max use frequency (Hz)	Weight (Kg)
CGPT-20	158	79	180	94	4	2 ÷ 8	5 ÷ 60	0.02	3	0.15
CGPT-20-NC	198	99	120	60	4	4 ÷ 8	5 ÷ 60	0.02	3	0.2
CGPT-20-NO	100	50	220	110	4	4 ÷ 8	5 ÷ 60	0.02	3	0.18

CGPT gripper, size 25 mm - dimensions



DRAWING LEGEND:
 A = Opening of air connection
 B = Closing of air connection
 C = Closed gripper
 D = Open gripper

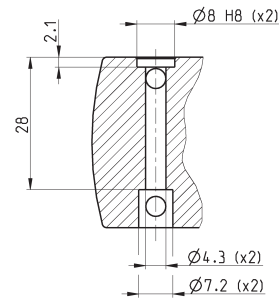
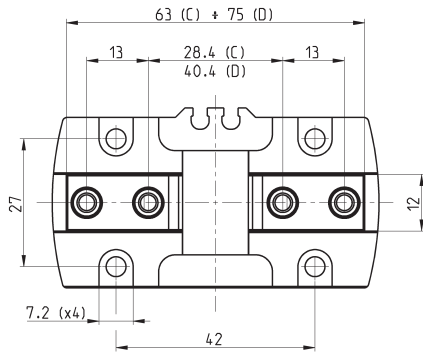
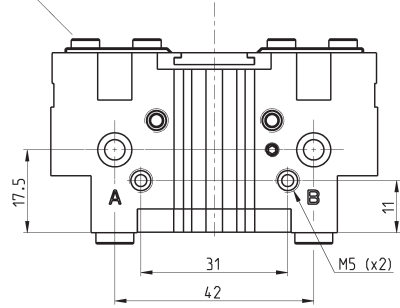
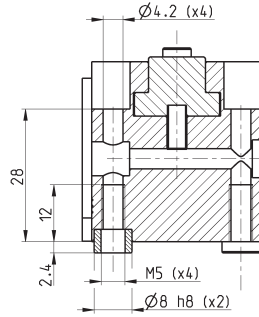
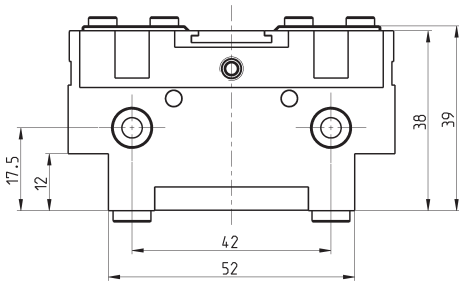
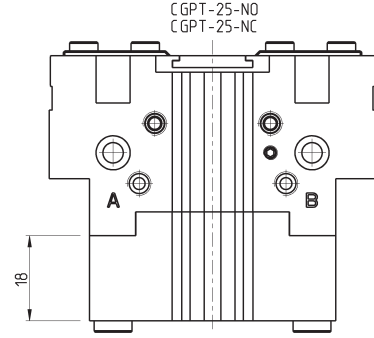
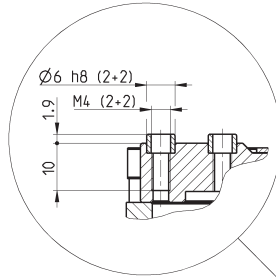
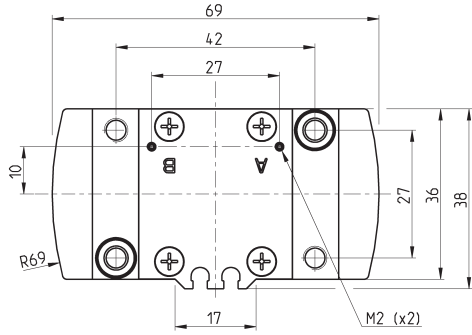

Mod.	Total closing gripping force at 6 bar (N)	Closing gripping force each jaw at 6 bar (N)	Total opening gripping force at 6 bar (N)	Opening gripping force each jaw at 6 bar (N)	Stroke per jaw (mm)	Working pressure (bar)	Working temperature (°C)	Repeatability (mm)	Max use frequency (Hz)	Weight (Kg)
CGPT-25	230	115	266	133	6	2 ÷ 8	5 ÷ 60	0.02	3	0.27
CGPT-25-NC	280	140	200	100	6	4 ÷ 8	5 ÷ 60	0.02	3	0.35
CGPT-25-NO	166	83	316	158	6	4 ÷ 8	5 ÷ 60	0.02	3	0.33

CGPT gripper, size 32 mm - dimensions



DRAWING LEGEND:

- A = Opening of air connection
- B = Closing of air connection
- C = Closed gripper
- D = Open gripper

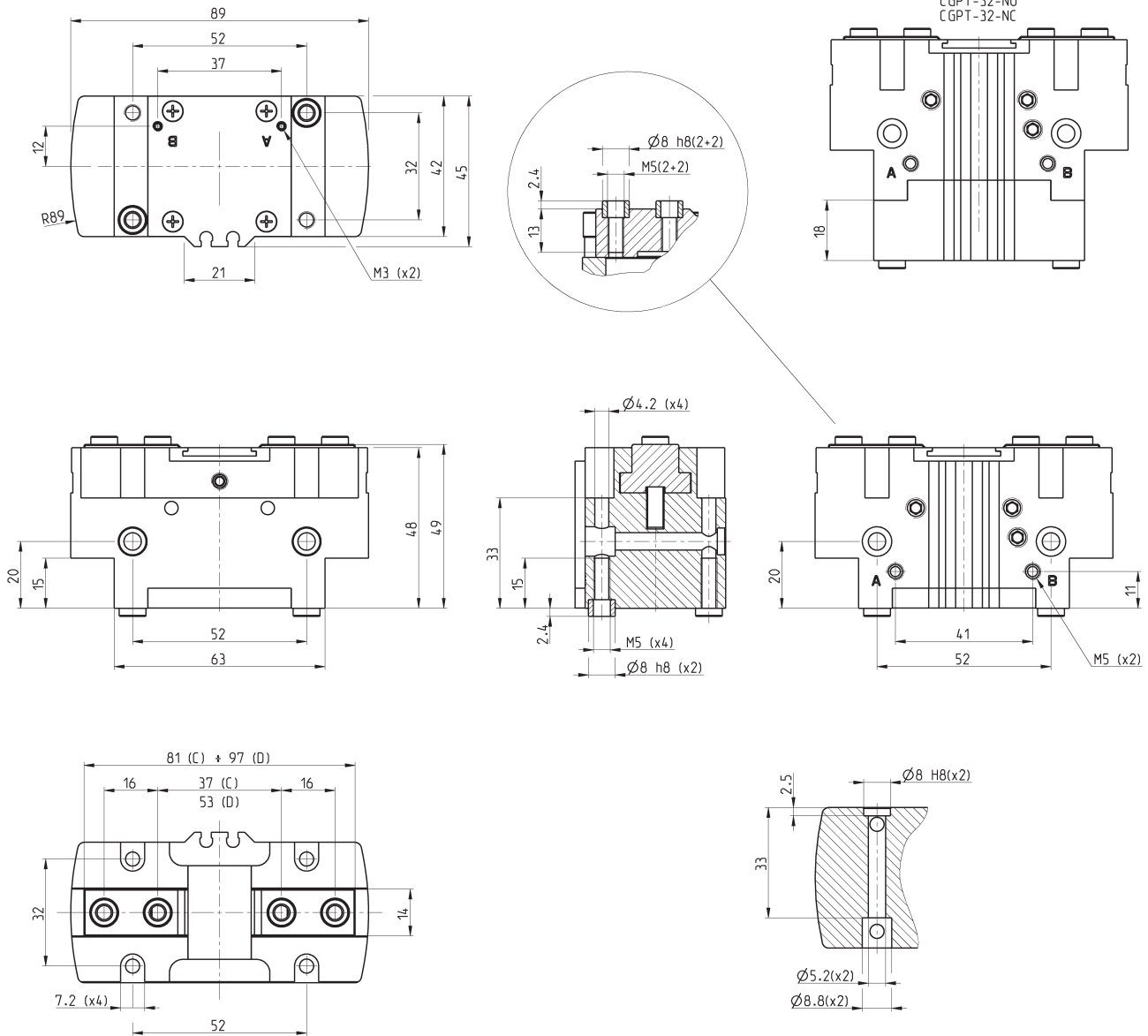

Mod.	Total closing gripping force at 6 bar (N)	Closing gripping force each jaw at 6 bar (N)	Total opening gripping force at 6 bar (N)	Opening gripping force each jaw at 6 bar (N)	Stroke per jaw (mm)	Working pressure (bar)	Working temperature (°C)	Repeatability (mm)	Max use frequency (Hz)	Weight (Kg)
CGPT-32	388	194	450	225	8	2 ÷ 8	5 ÷ 60	0.02	3	0.5
CGPT-32-NC	456	228	354	177	8	4 ÷ 8	5 ÷ 60	0.02	3	0.61
CGPT-32-NO	300	150	512	256	8	4 ÷ 8	5 ÷ 60	0.02	3	0.59

CGPT gripper, size 40 mm - dimensions



DRAWING LEGEND:
 A = Opening of air connection
 B = Closing of air connection
 C = Closed gripper
 D = Open gripper

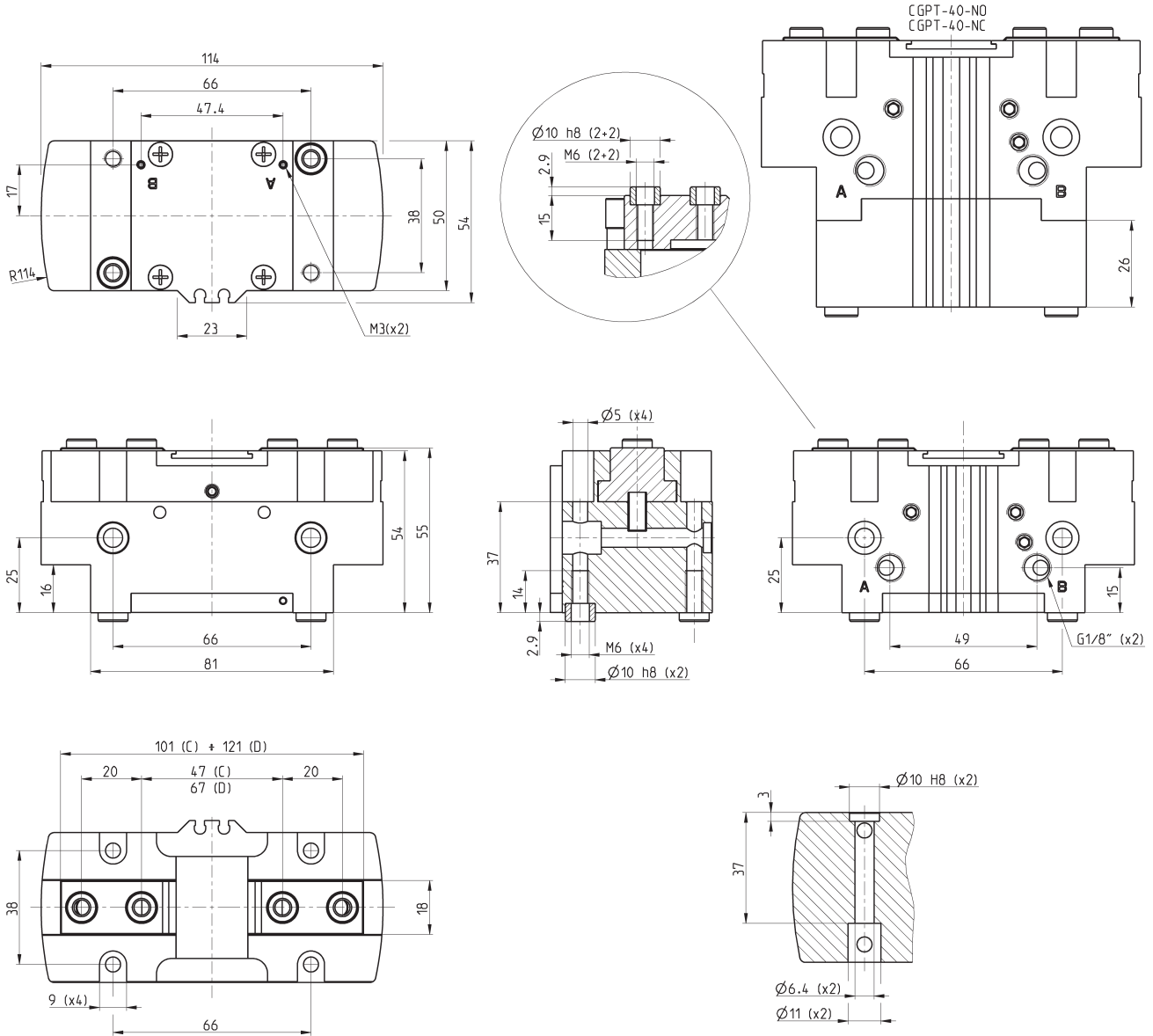

Mod.	Total closing gripping force at 6 bar (N)	Closing gripping force each jaw at 6 bar (N)	Total opening gripping force at 6 bar (N)	Opening gripping force each jaw at 6 bar (N)	Stroke per jaw (mm)	Working pressure (bar)	Working temperature (°C)	Repeatability (mm)	Max use frequency (Hz)	Weight (Kg)
CGPT-40	670	335	720	360	10	2 ÷ 8	5 ÷ 60	0.02	2	0.83
CGPT-40-NC	740	370	504	252	10	4 ÷ 8	5 ÷ 60	0.02	2	1.2
CGPT-40-NO	430	215	820	410	10	4 ÷ 8	5 ÷ 60	0.02	2	1.1

CGPT gripper, size 50 mm - dimensions



DRAWING LEGEND:

- A = Opening of air connection
- B = Closing of air connection
- C = Closed gripper
- D = Open gripper

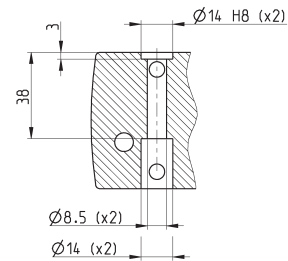
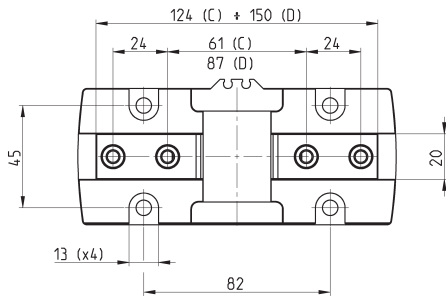
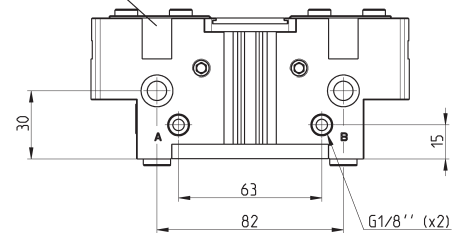
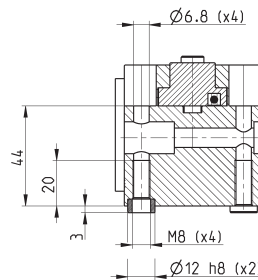
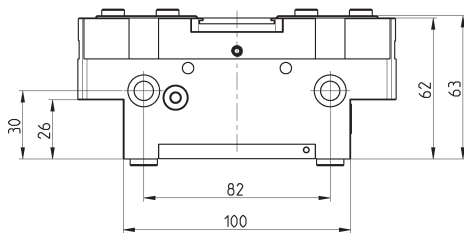
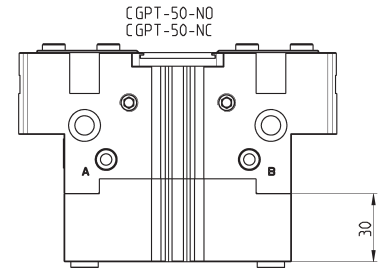
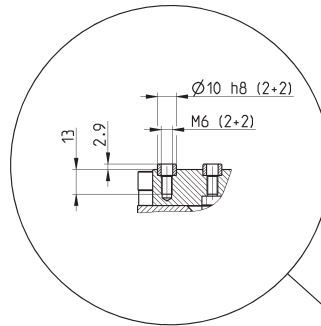
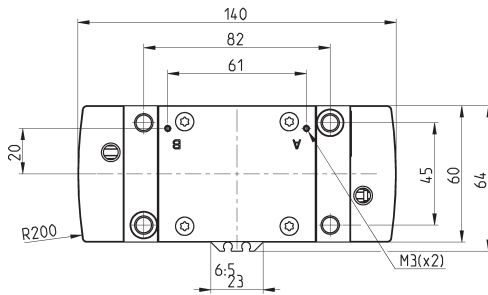

Mod.	Total closing gripping force at 6 bar (N)	Closing gripping force each jaw at 6 bar (N)	Total opening gripping force at 6 bar (N)	Opening gripping force each jaw at 6 bar (N)	Stroke per jaw (mm)	Working pressure (bar)	Working temperature (°C)	Repeatability (mm)	Max use frequency (Hz)	Weight (Kg)
CGPT-50	1044	522	1208	604	13	2 ÷ 8	5 ÷ 60	0,02	1	1,45
CGPT-50-NC	1380	690	778	389	13	4 ÷ 8	5 ÷ 60	0,02	1	1,72
CGPT-50-NO	642	321	1524	762	13	4 ÷ 8	5 ÷ 60	0,02	1	1,89

CGPT gripper, size 63 mm - dimensions



DRAWING LEGEND:
A = Opening of air connection
B = Closing of air connection
C = Closed gripper
D = Open gripper

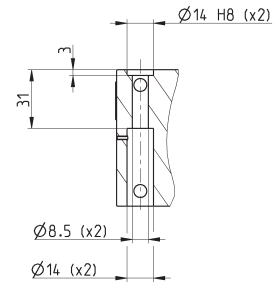
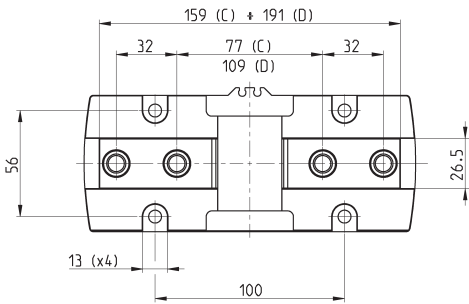
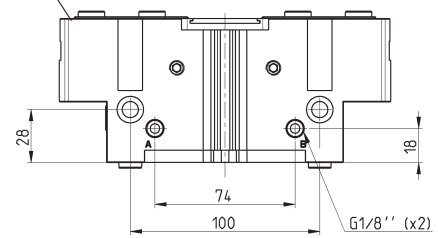
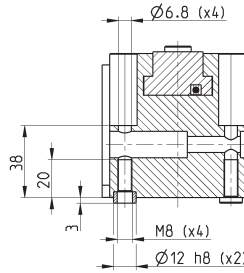
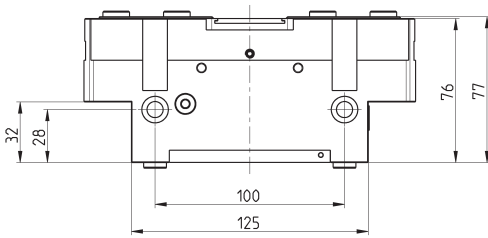
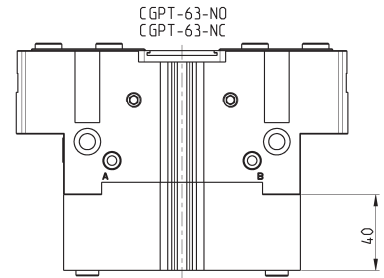
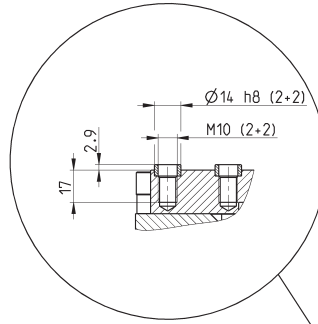
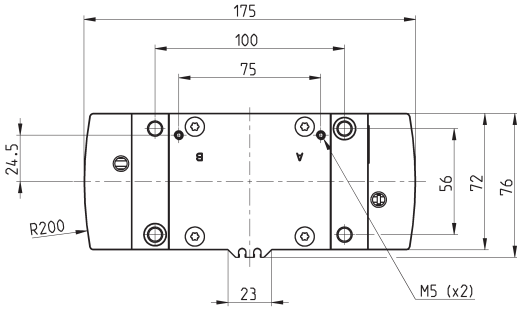

Mod.	Total closing gripping force at 6 bar (N)	Closing gripping force each jaw at 6 bar (N)	Total opening gripping force at 6 bar (N)	Opening gripping force each jaw at 6 bar (N)	Stroke per jaw (mm)	Working pressure (bar)	Working temperature (°C)	Repeatability (mm)	Max use frequency (Hz)	Weight (Kg)
CGPT-63	1486	743	1722	861	16	2 ÷ 8	5 ÷ 60	0.02	3	2,69
CGPT-63-NC	1910	955	1144	572	16	4 ÷ 8	5 ÷ 60	0.02	2	3,32
CGPT-63-NO	946	473	2108	1054	16	4 ÷ 8	5 ÷ 60	0.02	2	3,28

CGPT gripper, size 80 mm - dimensions



DRAWING LEGEND:

- A = Opening of air connection
- B = Closing of air connection
- C = Closed gripper
- D = Open gripper

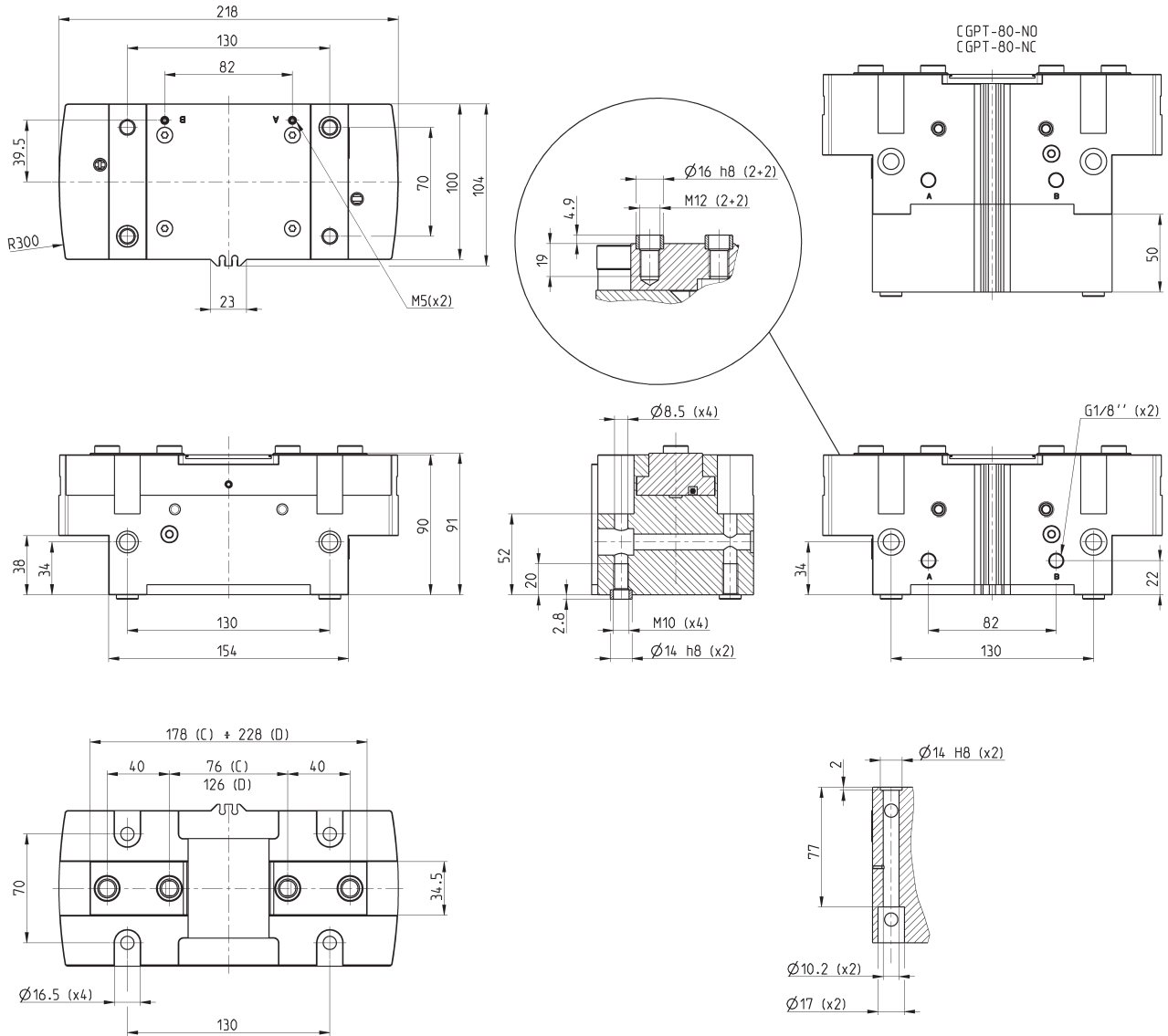

Mod.	Total closing gripping force at 6 bar (N)	Closing gripping force each jaw at 6 bar (N)	Total opening gripping force at 6 bar (N)	Opening gripping force each jaw at 6 bar (N)	Stroke per jaw (mm)	Working pressure (bar)	Working temperature (°C)	Repeatability (mm)	Max use frequency (Hz)	Weight (Kg)
CGPT-80	2818	1409	3168	1584	25	2 ÷ 8	5 ÷ 60	0,02	1	5,16
CGPT-80-NC	3698	1849	2052	1026	25	4 ÷ 8	5 ÷ 60	0,02	1	6,89
CGPT-80-NO	1756	878	4006	2003	25	4 ÷ 8	5 ÷ 60	0,02	1	6,66

GRIPPING FORCE (F) PER SINGLE JAW

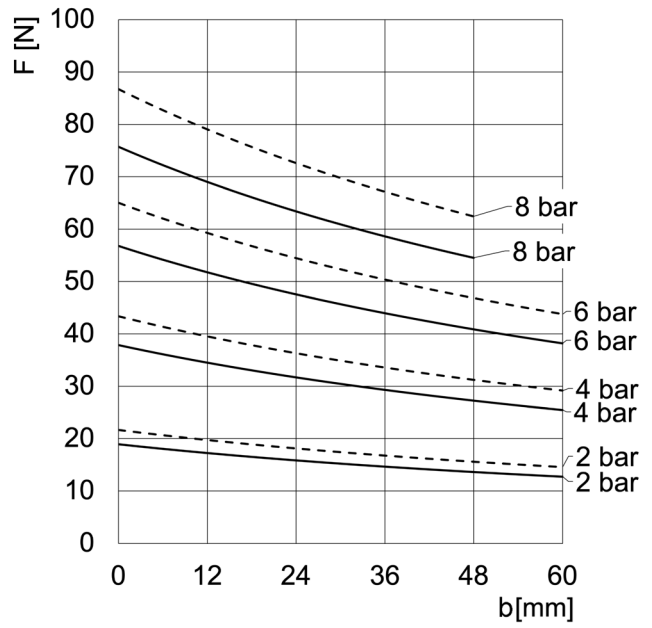
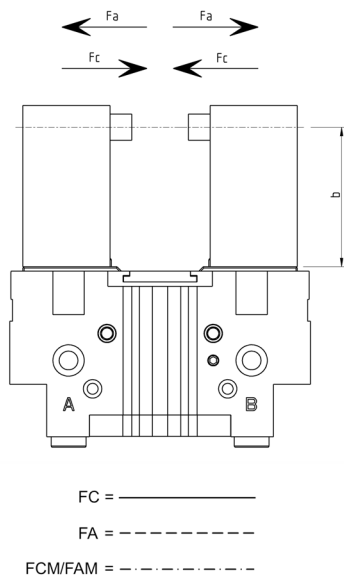

CGPT-16

b = distance from gripping point
 F_a = opening force
 F_c = closing force
 F_{AM} = opening gripping force
 F_{CM} = closing gripping force

The total gripping force has to be calculated as follows:
 Total $F = F \times 2$

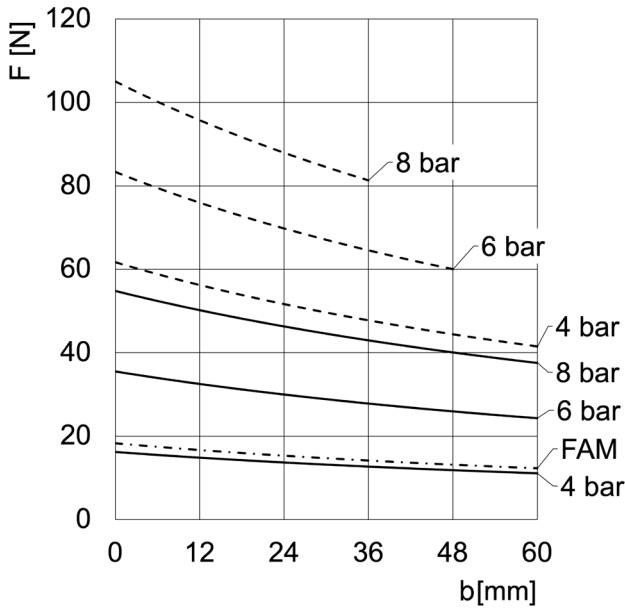

CGPT-16-NO

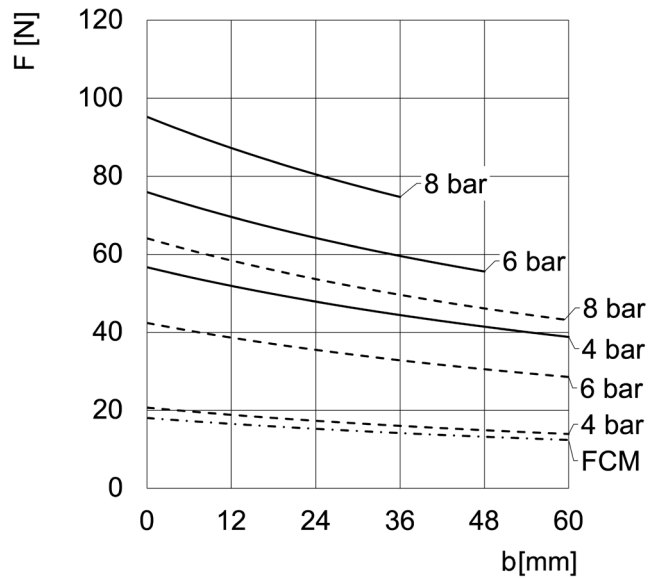

CGPT-16-NC

GRIPPING FORCE (F) PER SINGLE JAW

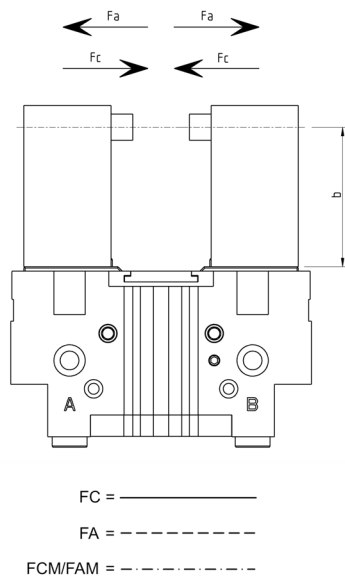

b = distance from gripping point
F_a = opening force
F_c = closing force
F_{AM} = opening gripping force
F_{CM} = closing gripping force

The total gripping force has to be calculated as follows:
Total F = F x 2

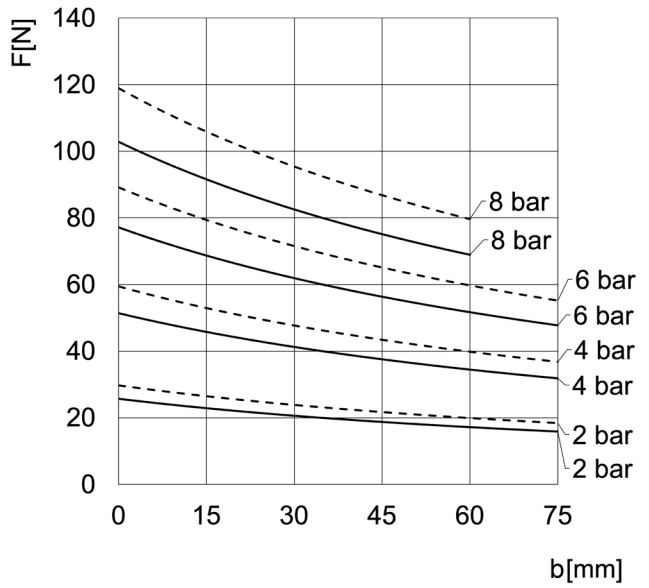

CGPT-20

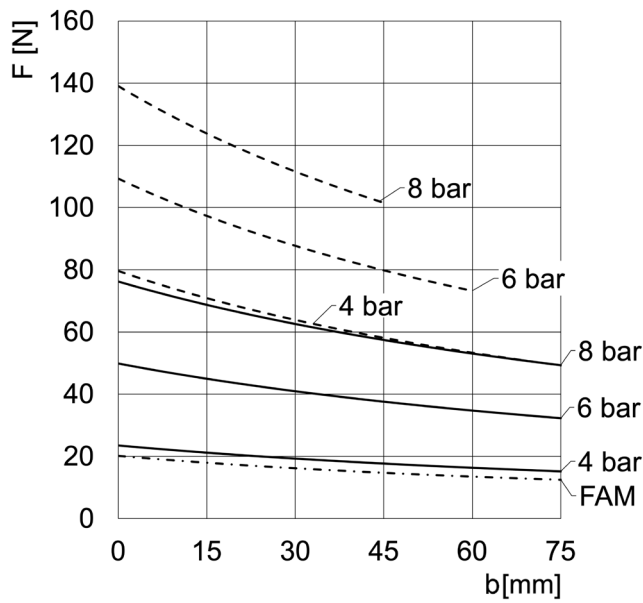

CGPT-20-NO

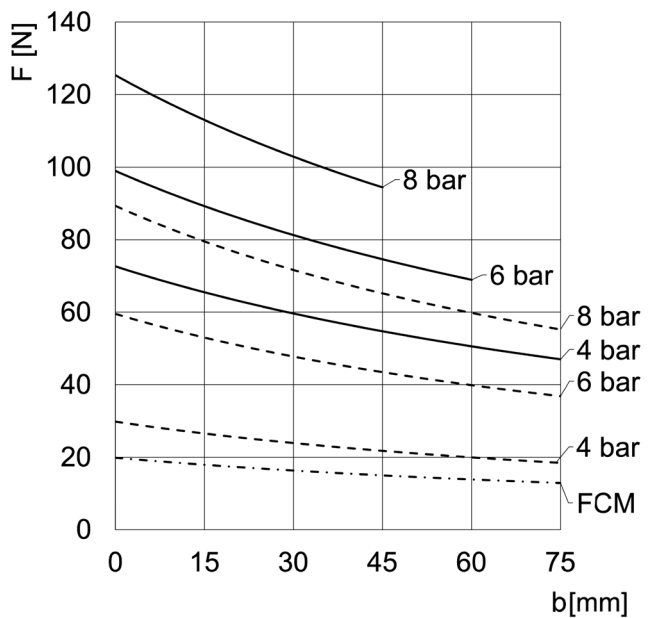

CGPT-20-NC

GRIPPING FORCE (F) PER SINGLE JAW

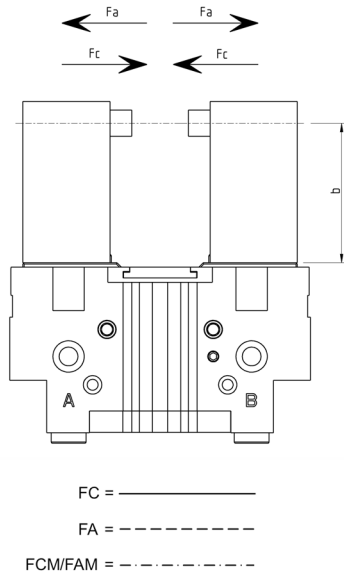

b = distance from gripping point
 F_a = opening force
 F_c = closing force
 F_{AM} = opening gripping force
 F_{CM} = closing gripping force

The total gripping force has to be calculated as follows:
 Total $F = F \times 2$

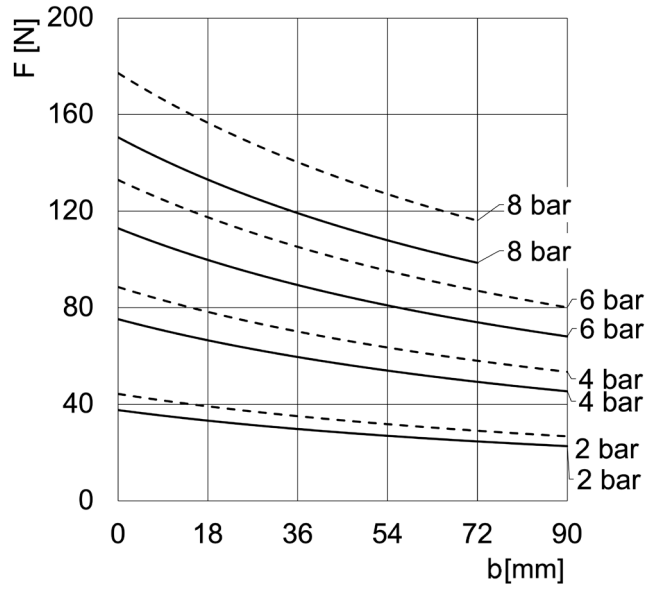

CGPT-25

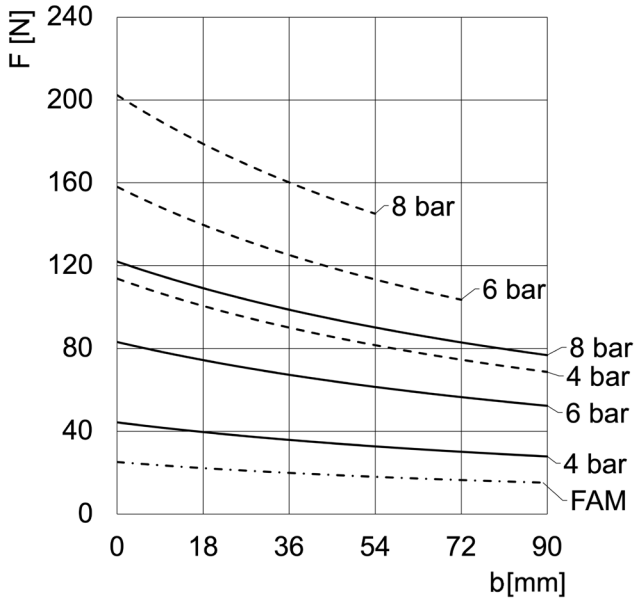

CGPT-25-NO

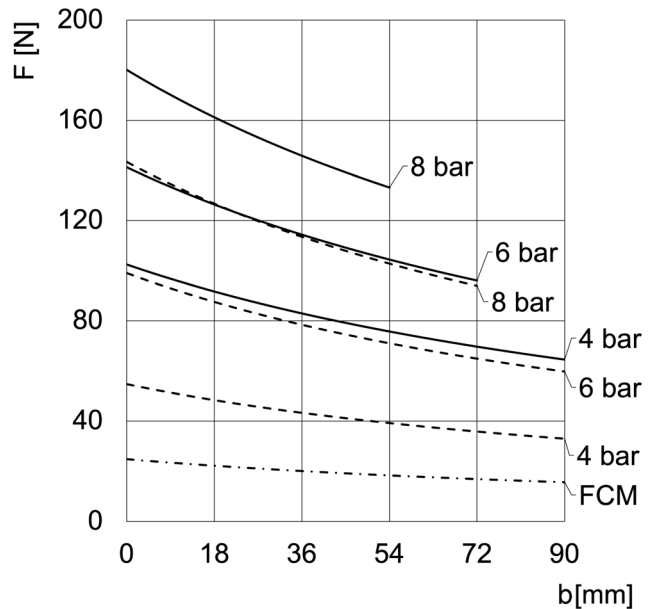

CGPT-25-NC

GRIPPING FORCE (F) PER SINGLE JAW

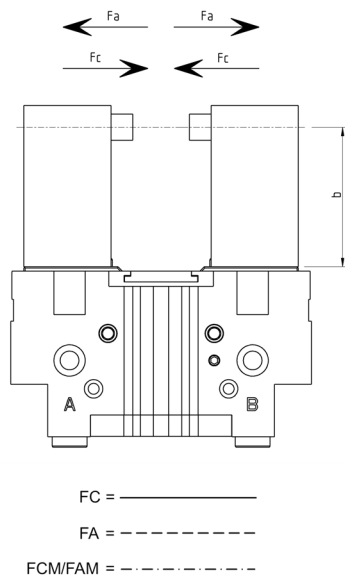

b = distance from gripping point
F_a = opening force
F_c = closing force
F_{AM} = opening gripping force
F_{CM} = closing gripping force

The total gripping force has to be calculated as follows:
 Total $F = F \times 2$

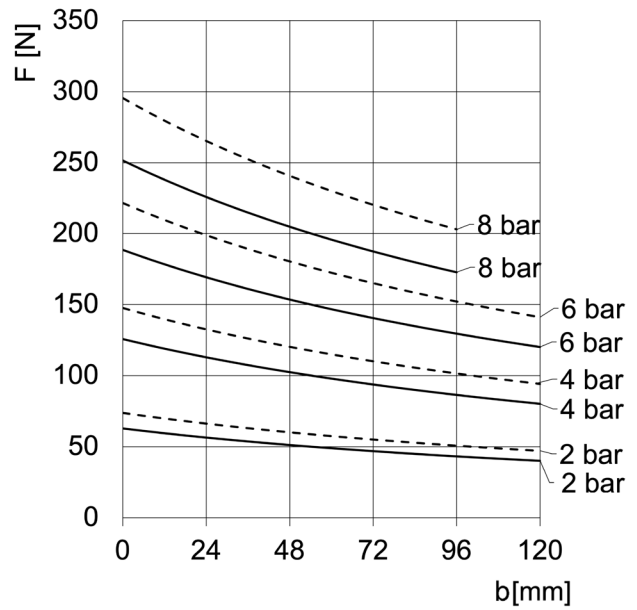

CGPT-32

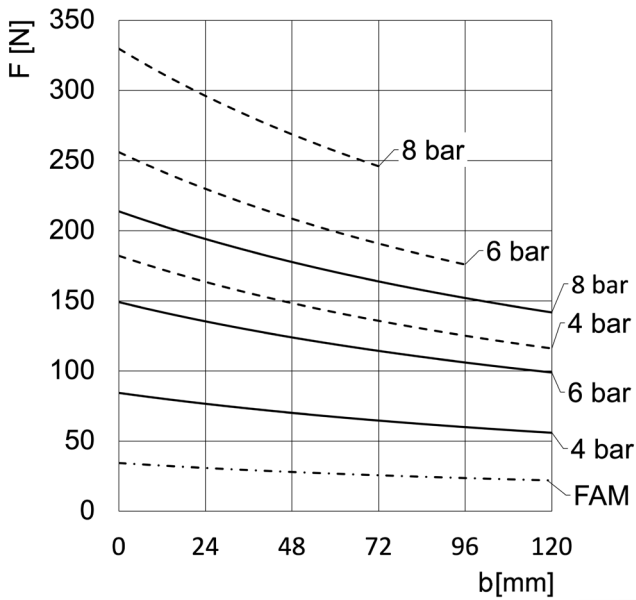

CGPT-32-NO

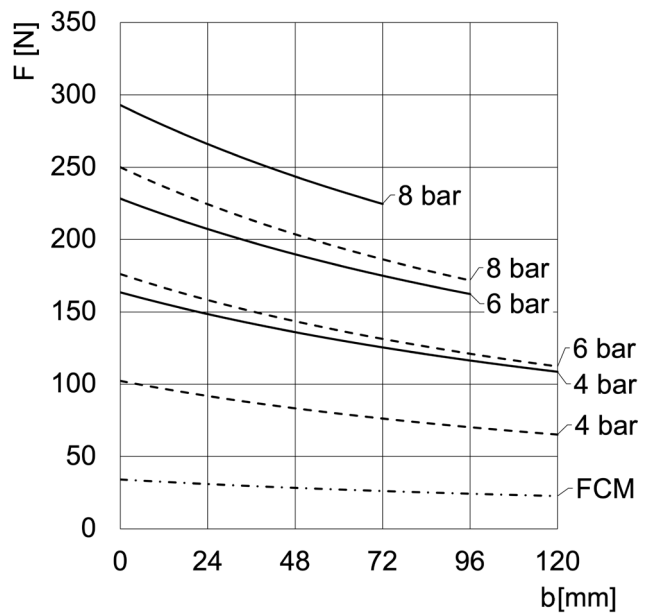

CGPT-32-NC

GRIPPING FORCE (F) PER SINGLE JAW

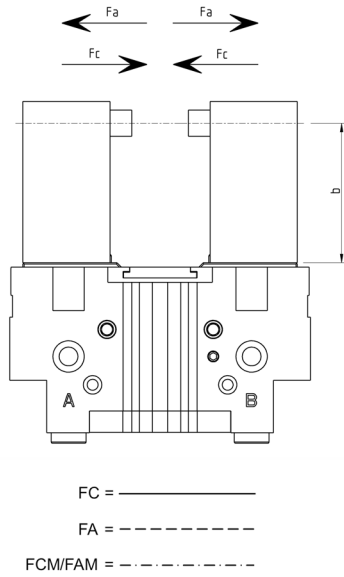

b = distance from gripping point
 F_a = opening force
 F_c = closing force
 F_{AM} = opening gripping force
 F_{CM} = closing gripping force

The total gripping force has to be calculated as follows:
 Total $F = F \times 2$

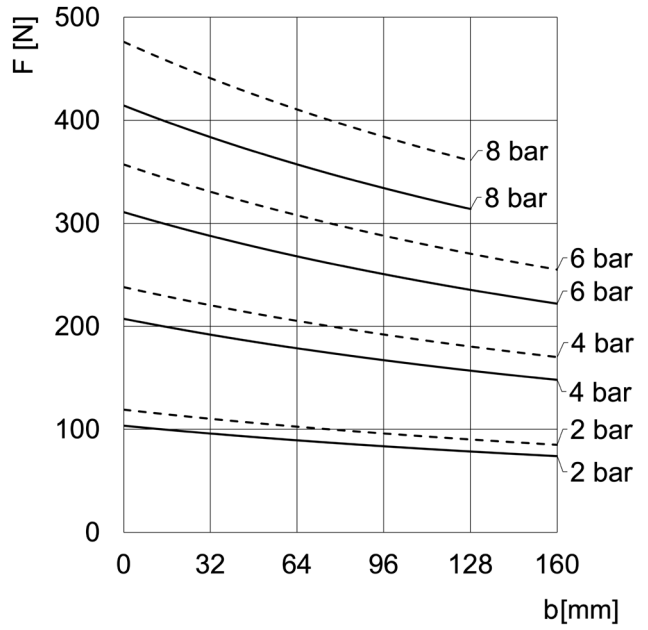

CGPT-40

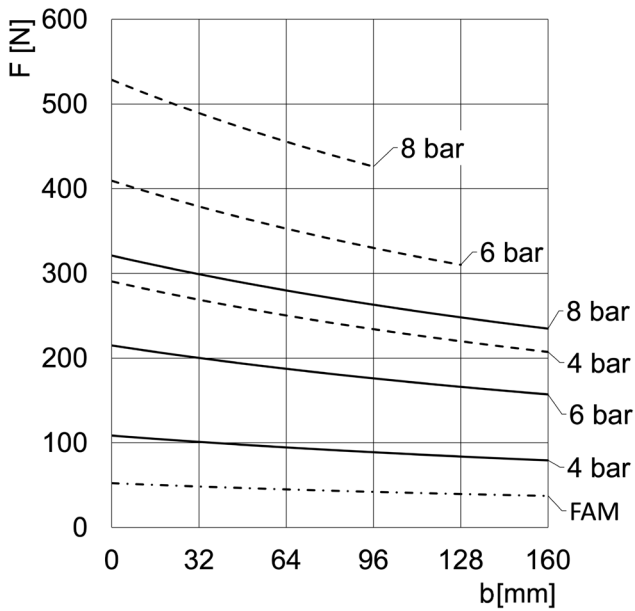

CGPT-40-NO

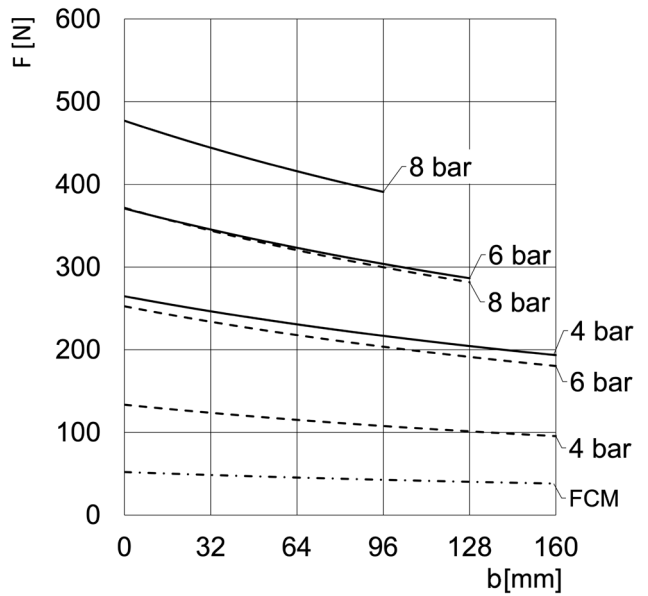

CGPT-40-NC

GRIPPING FORCE (F) PER SINGLE JAW

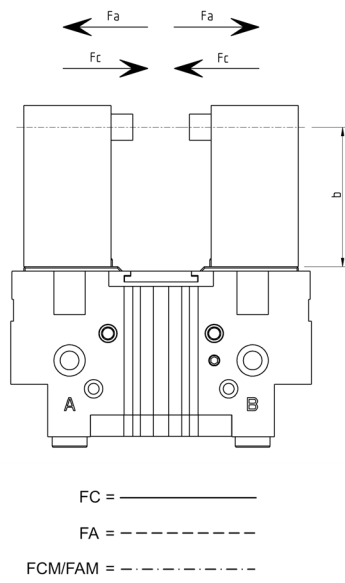

b = distance from gripping point
F_a = opening force
F_c = closing force
F_{AM} = opening gripping force
F_{CM} = closing gripping force

The total gripping force has to be calculated as follows:
Total F = F x 2

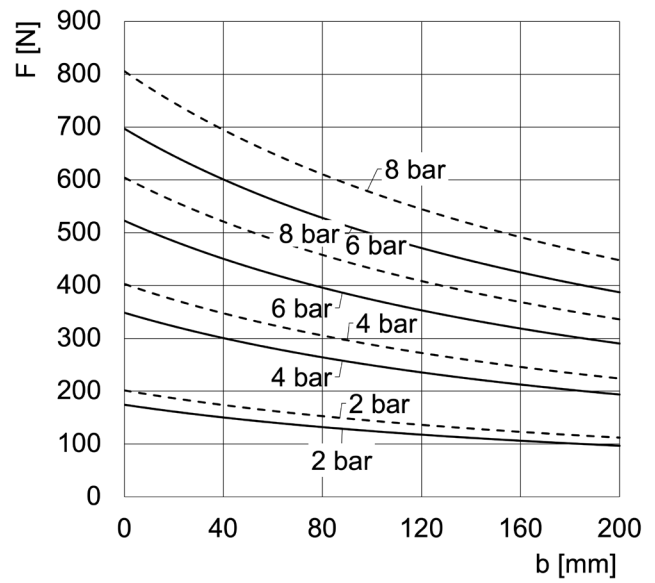

CGPT-50

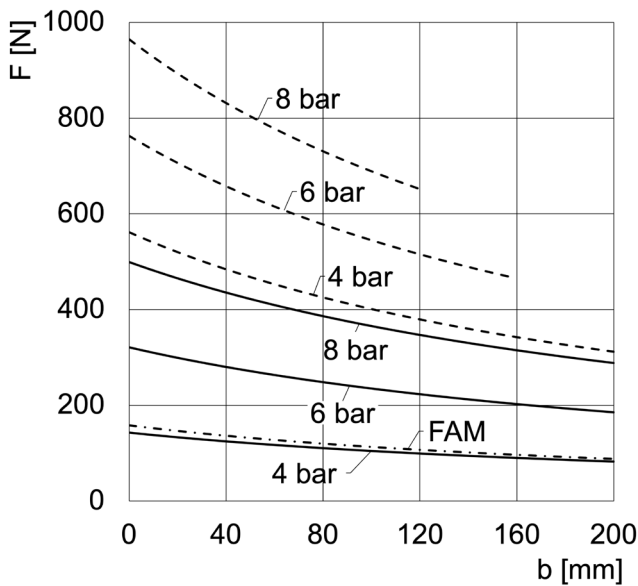

CGPT-50-NO

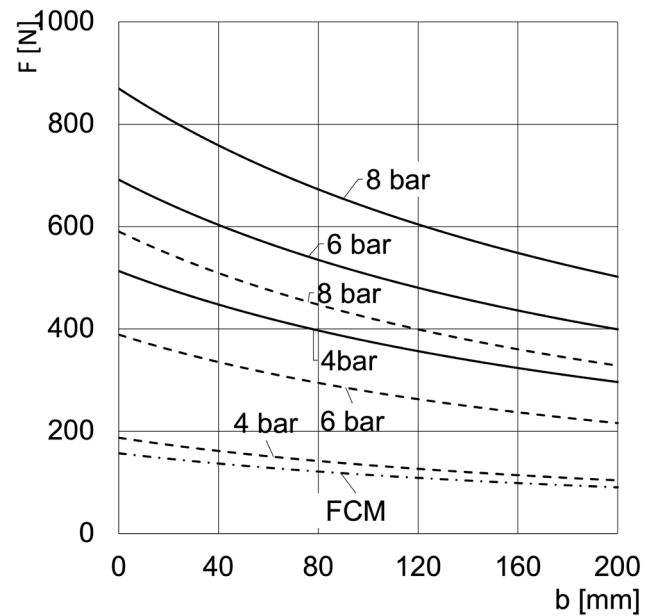

CGPT-50-NC

SERIES CGPT PARALLEL GRIPPERS WITH T-GUIDE

GRIPPING FORCE (F) PER SINGLE JAW

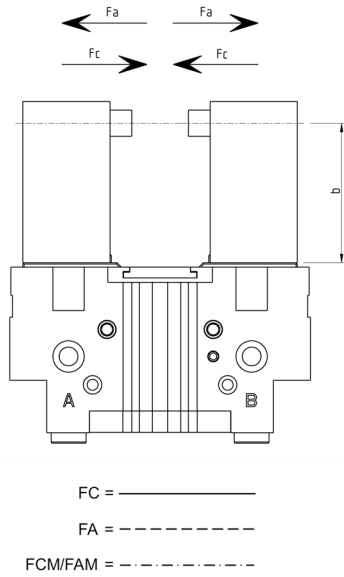

b = distance from gripping point
 F_A = opening force
 F_C = closing force
 F_{AM} = opening gripping force
 F_{CM} = closing gripping force

The total gripping force has to be calculated as follows:
 Total $F = F \times 2$

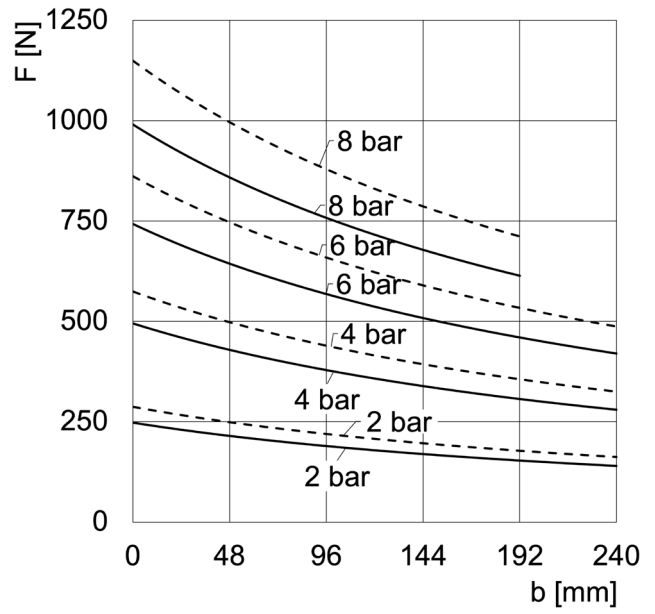

CGPT-63

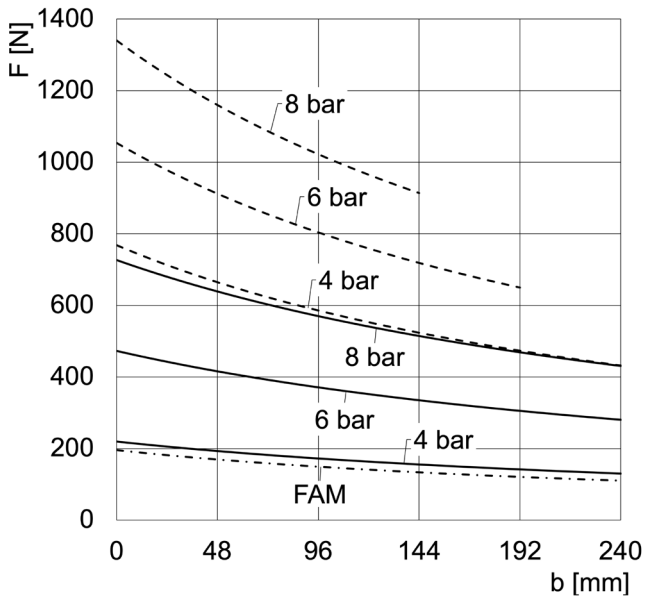

CGPT-63-NO

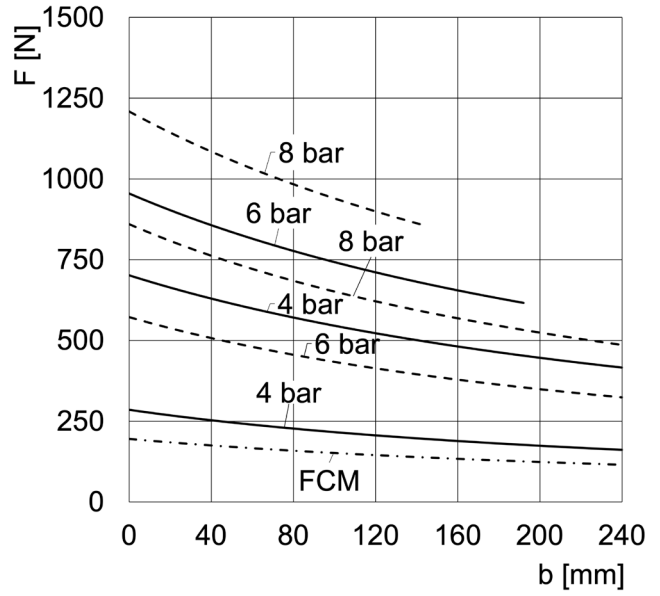

CGPT-63-NC

GRIPPING FORCE (F) PER SINGLE JAW

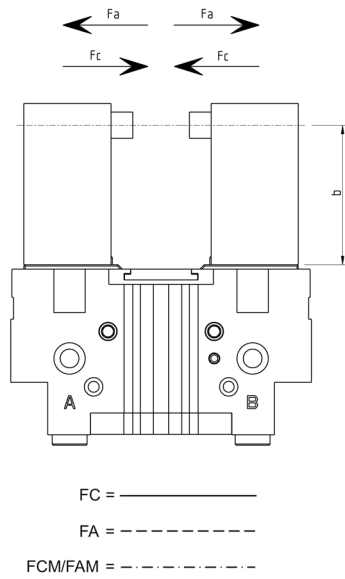

b = distance from gripping point
F_a = opening force
F_c = closing force
F_{AM} = opening gripping force
F_{CM} = closing gripping force

The total gripping force has to be calculated as follows:
Total F = F x 2

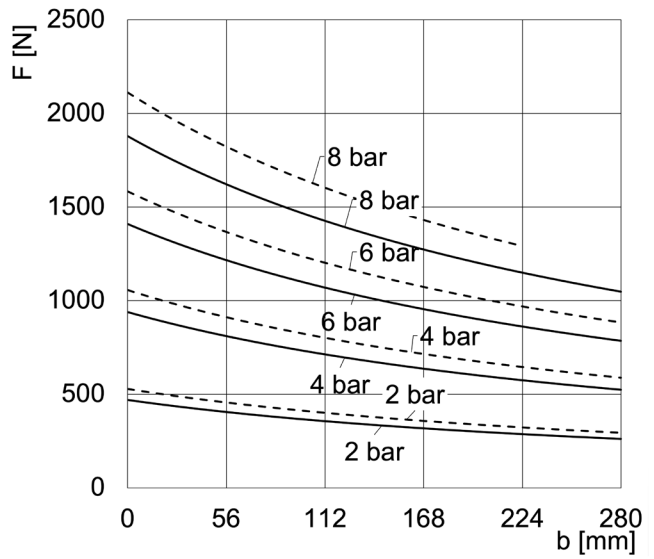

CGPT-80

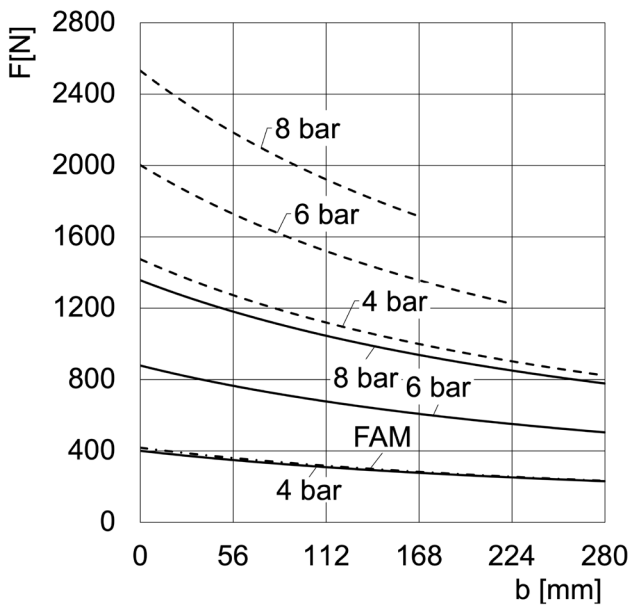

CGPT-80-NO

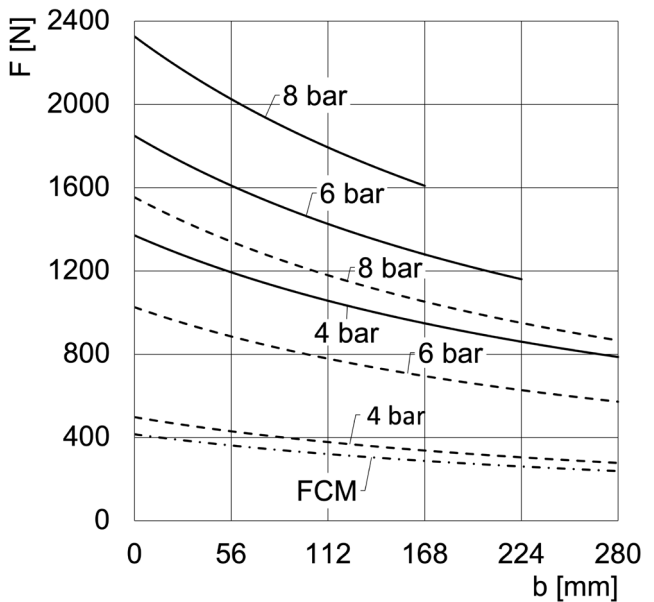

CGPT-80-NC

Length vs eccentricity CGPT-16

The total gripping force has to be calculated as follows: Total F = F x 2
Range of use of the gripper according to gripping point (b) and the arm (e).

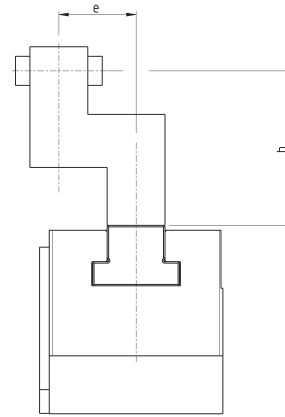

SERIES CGPT PARALLEL GRIPPERS WITH T-GUIDE

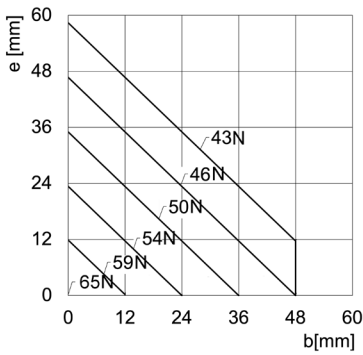

CGPT-16 opening

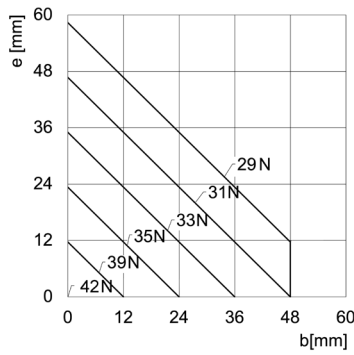

CGPT-16-NC opening

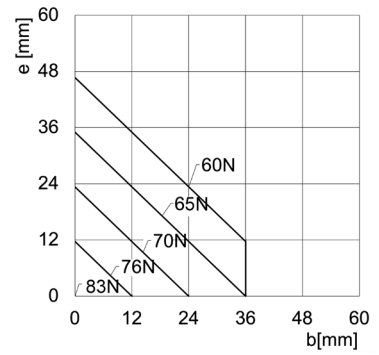

CGPT-16-NO opening

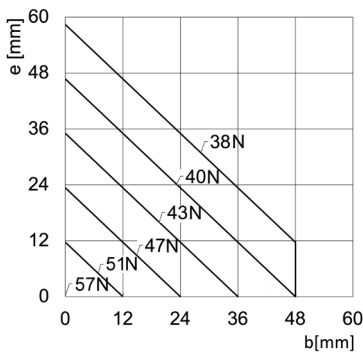

CGPT-16 closing

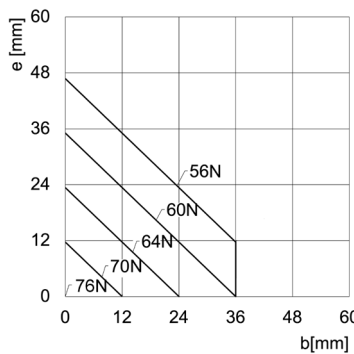

CGPT-16-NC closing

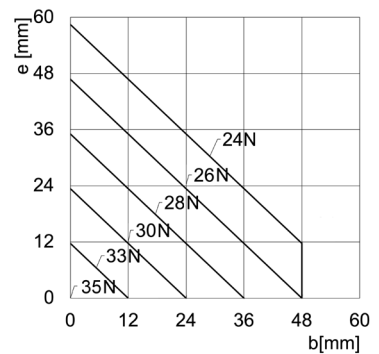

CGPT-16-NO closing

Length vs eccentricity CGPT-20

The total gripping force has to be calculated as follows: Total F = F x 2
 Range of use of the gripper according to gripping point (b) and the arm (e).

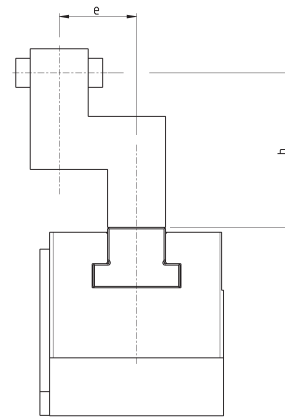

SERIES CGPT PARALLEL GRIPPERS WITH T-GUIDE

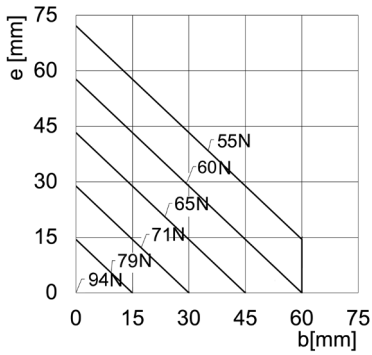

CGPT-20 opening

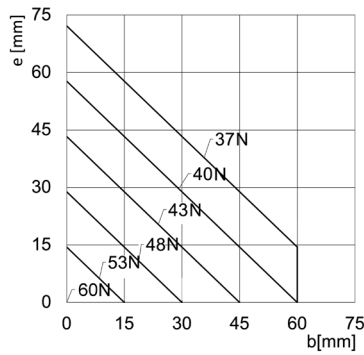

CGPT-20-NC opening

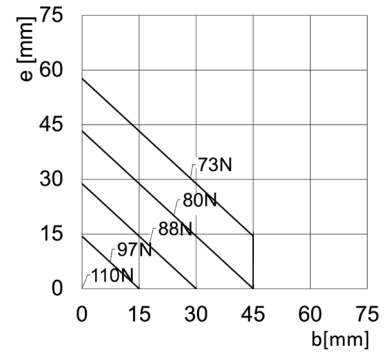

CGPT-20-NO opening

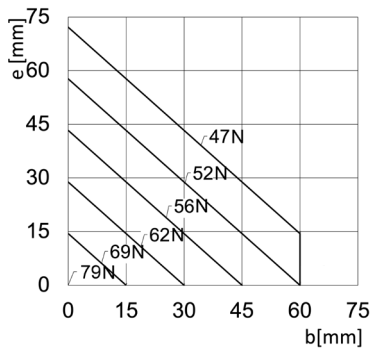

CGPT-20 closing

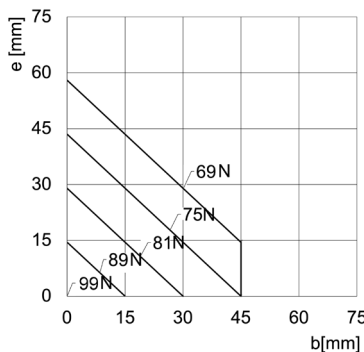

CGPT-20-NC closing

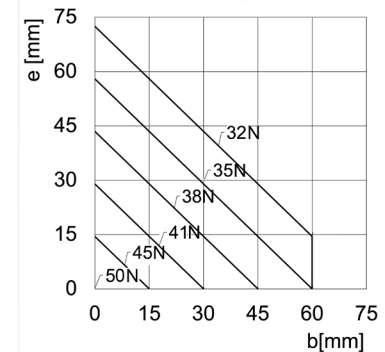

CGPT-20-NO closing

Length vs eccentricity CGPT-25

The total gripping force has to be calculated as follows: Total F = F x 2
Range of use of the gripper according to gripping point (b) and the arm (e).

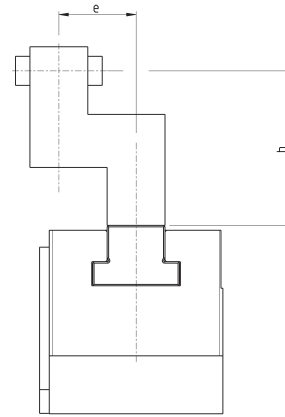

SERIES CGPT PARALLEL GRIPPERS WITH T-GUIDE

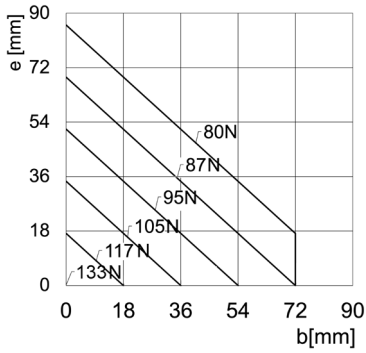

CGPT-25 opening

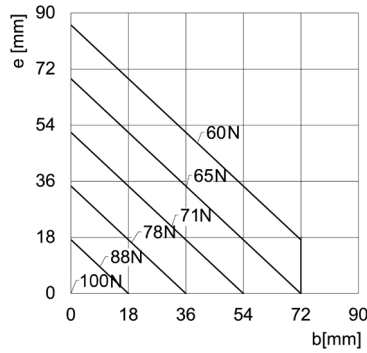

CGPT-25-NC opening

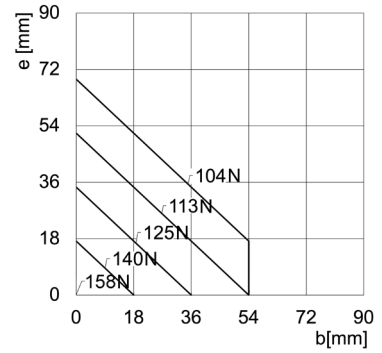

CGPT-25-NO opening

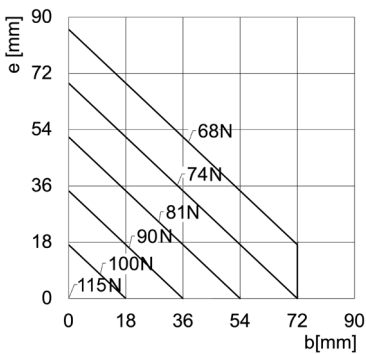

CGPT-25 closing

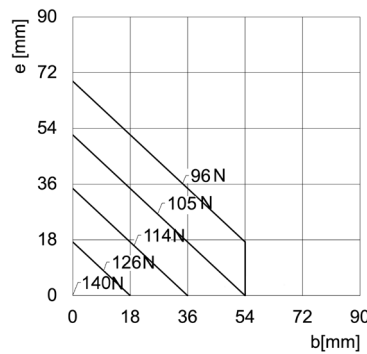

CGPT-25-NC closing

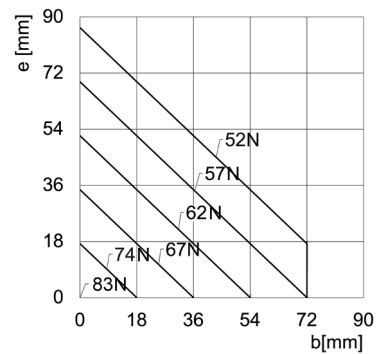

CGPT-25-NO closing

Length vs eccentricity CGPT-32

The total gripping force has to be calculated as follows: Total $F = F \times 2$

Range of use of the gripper according to gripping point (b) and the arm (e).

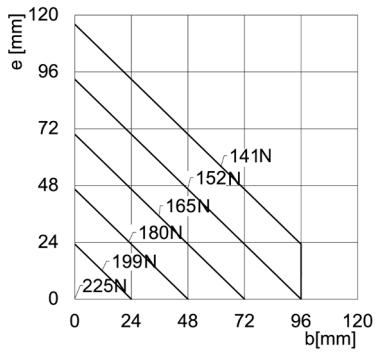
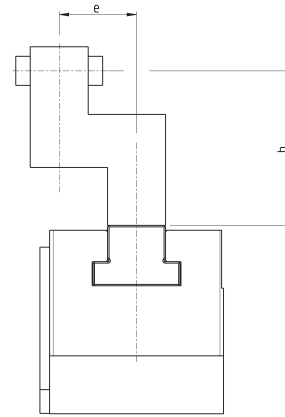

CGPT-32 opening

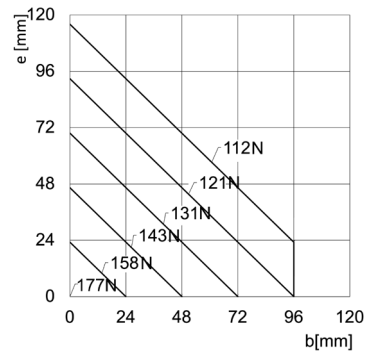

CGPT-32-NC opening

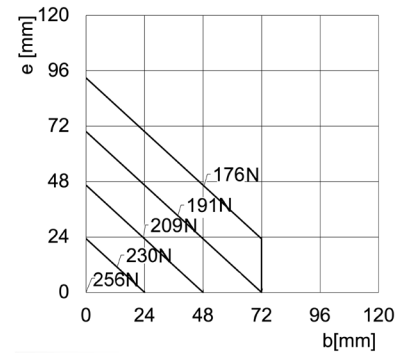

CGPT-32-NO opening

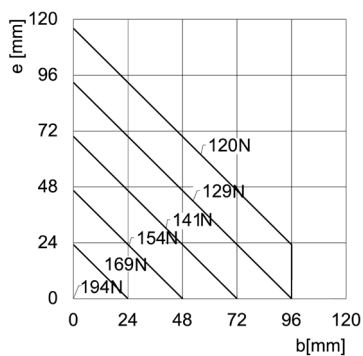

CGPT-32 closing

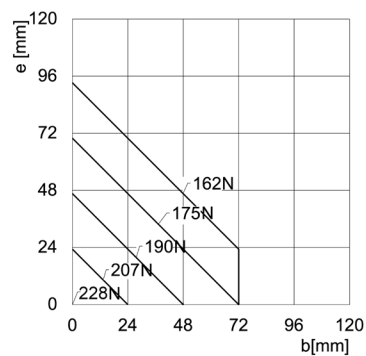

CGPT-32-NC closing

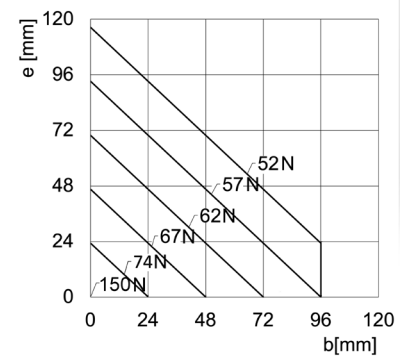

CGPT-32-NO closing

Length vs eccentricity CGPT-40

The total gripping force has to be calculated as follows: Total F = F x 2

Range of use of the gripper according to gripping point (b) and the arm (e).

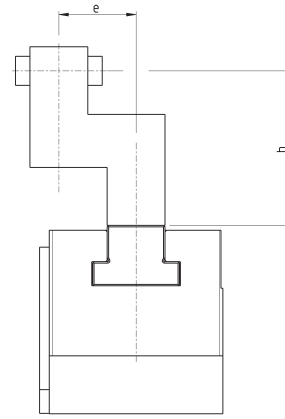

SERIES CGPT PARALLEL GRIPPERS WITH T-GUIDE

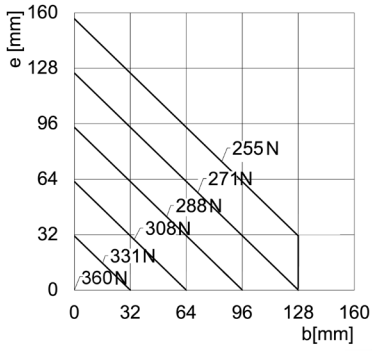

CGPT-40 opening

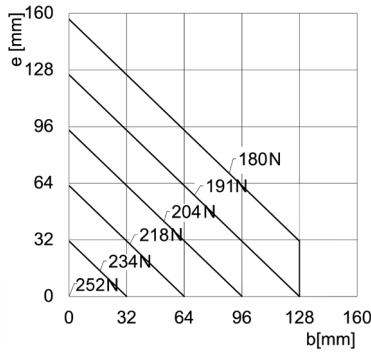

CGPT-40-NC opening

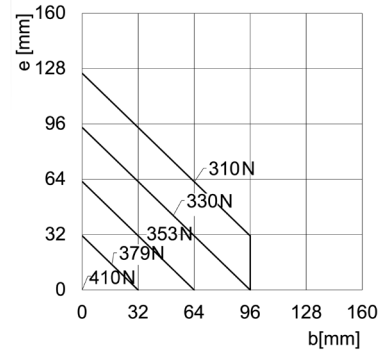

CGPT-40-NO opening

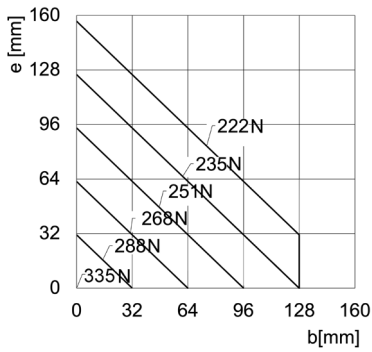

CGPT-40 closing

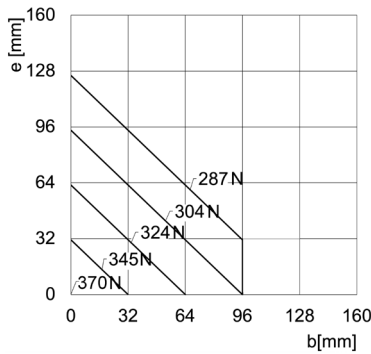

CGPT-40-NC closing

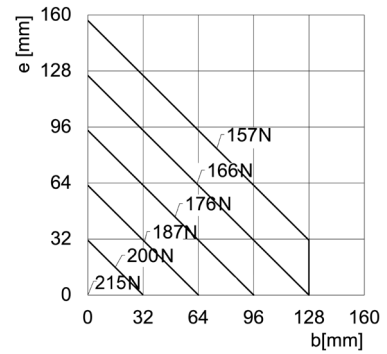

CGPT-40-NO closing

Length vs eccentricity CGPT-50

The total gripping force has to be calculated as follows: Total F = F x 2
 Range of use of the gripper according to gripping point (b) and the arm (e).

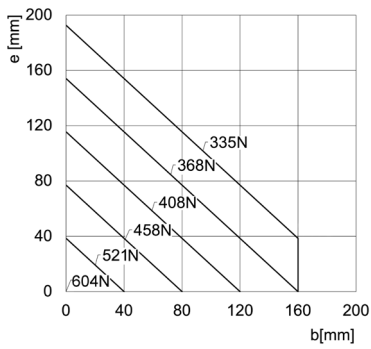
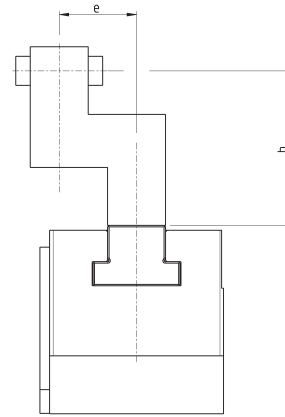

CGPT-50 opening

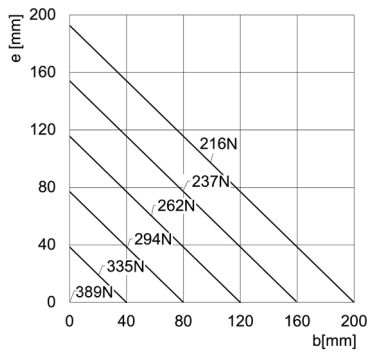

CGPT-50-NC opening

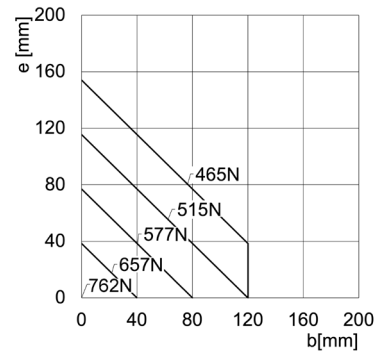

CGPT-50-NO opening

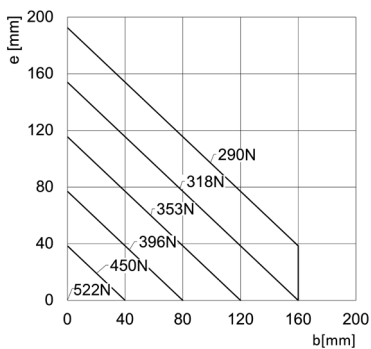

CGPT-50 closing

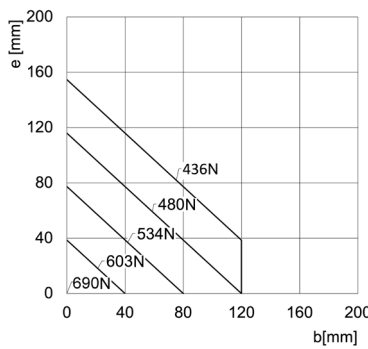

CGPT-50-NC closing

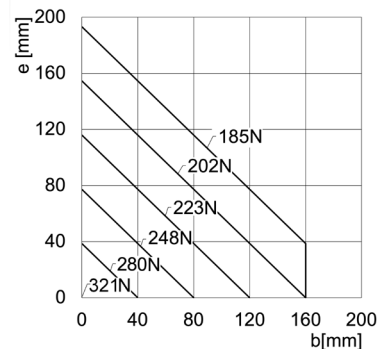

CGPT-50-NO closing

Length vs eccentricity CGPT-63

The total gripping force has to be calculated as follows: Total F = F x 2
Range of use of the gripper according to gripping point (b) and the arm (e).

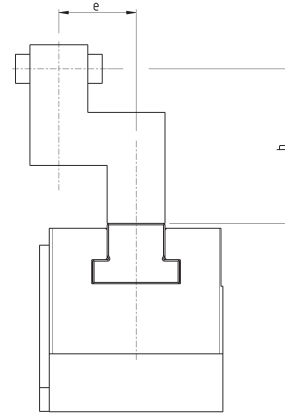

SERIES CGPT PARALLEL GRIPPERS WITH T-GUIDE

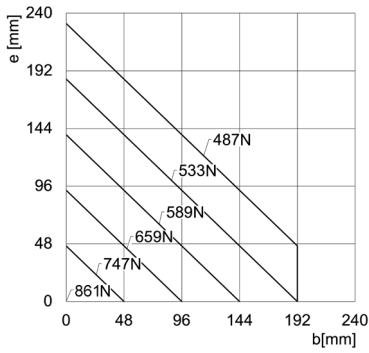

CGPT-63 opening

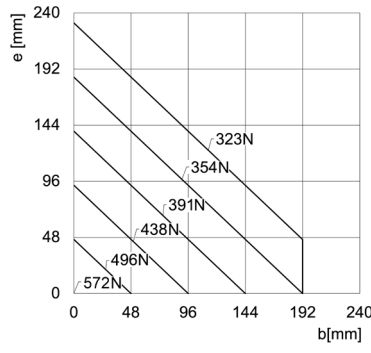

CGPT-63-NC opening

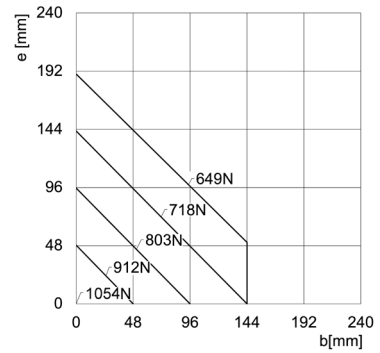

CGPT-63-NO opening

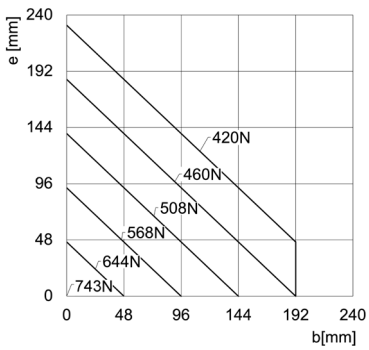

CGPT-63 closing

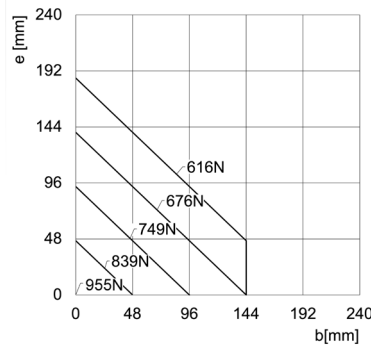

CGPT-63-NC closing

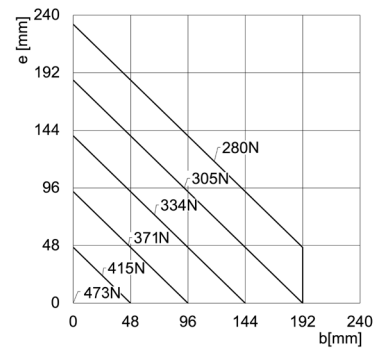

CGPT-63-NO closing

Length vs eccentricity CGPT-80

The total gripping force has to be calculated as follows: Total F = F x 2

Range of use of the gripper according to gripping point (b) and the arm (e).

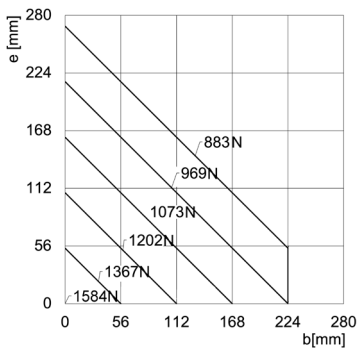
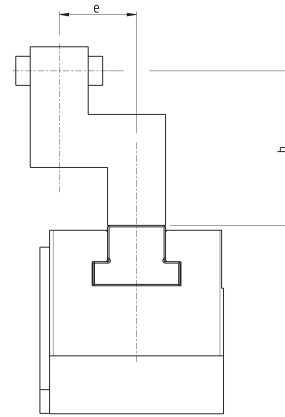

CGPT-80 opening

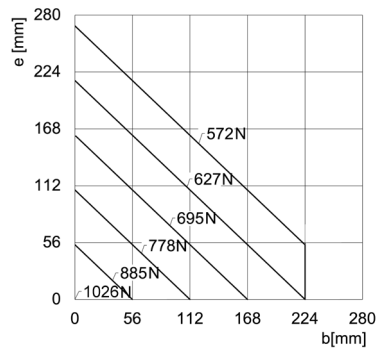

CGPT-80-NC opening

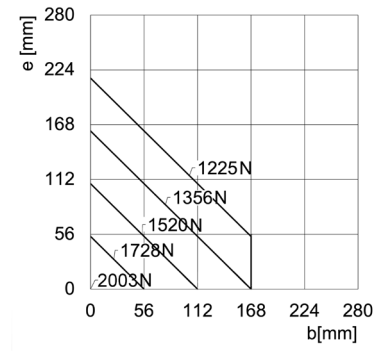

CGPT-80-NO opening

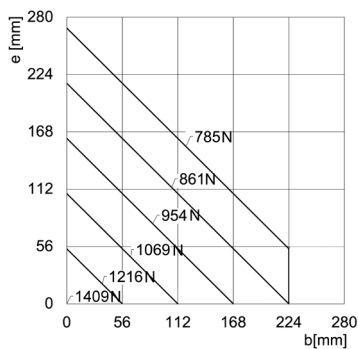

CGPT-80 closing

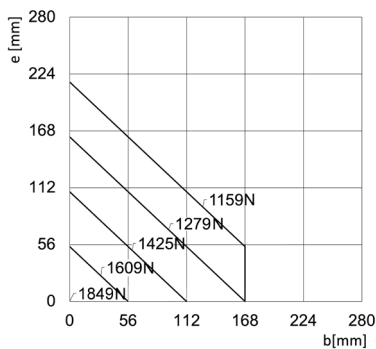

CGPT-80-NC closing

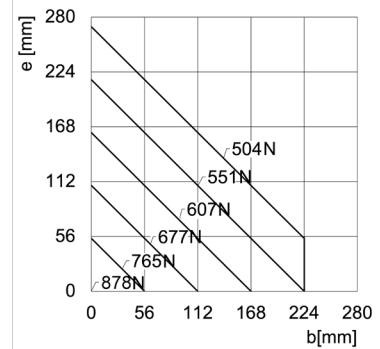

CGPT-80-NO closing

Examples of mounting

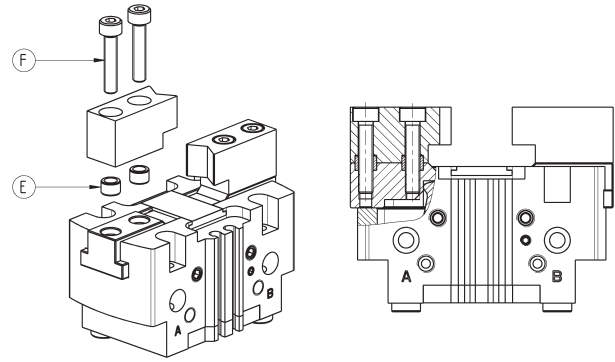
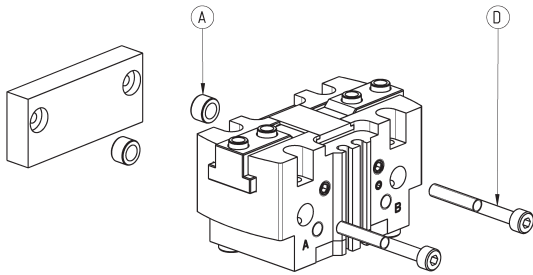
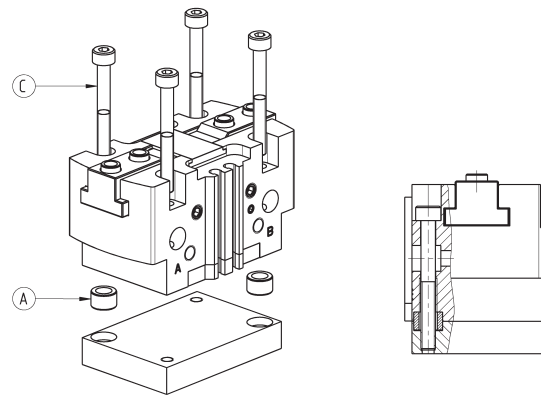
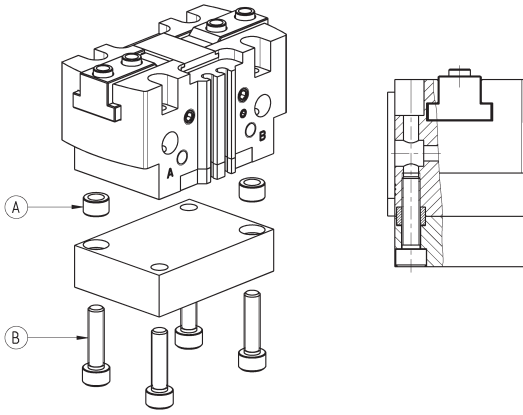

Mod.	A	B	C	D	E	F
CGPT-16	Ø5	M3	M2.5	M2.5	Ø4	M2.5
CGPT-20	Ø6	M4	M3	M3	Ø5	M3
CGPT-25	Ø8	M5	M4	M4	Ø6	M4
CGPT-32	Ø8	M5	M4	M5	Ø8	M5
CGPT-40	Ø10	M6	M5	M6	Ø10	M6
CGPT-50	Ø12	M8	M6	M8	Ø10	M6
CGPT-63	Ø12	M8	M6	M8	Ø14	M10
CGPT-80	Ø14	M10	M8	M10	Ø16	M12

Air supply ports

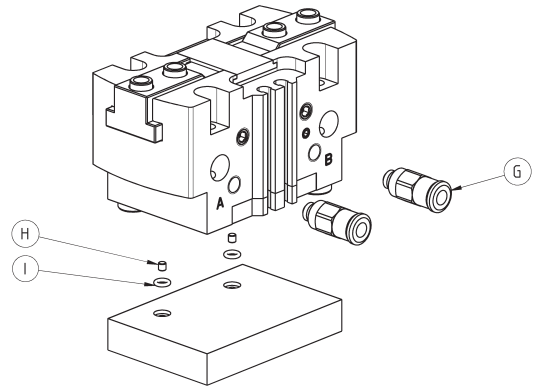

Mod.	G	H	I
CGPT-16	M3	M2	OR 2,5x1
CGPT-20	M5	M2	OR 2,5x1
CGPT-25	M5	M2	OR 2,5x1
CGPT-32	M5	M3	OR 3,5x1
CGPT-40	G1/8	M3	OR 3,5x1
CGPT-50	G1/8	M3	OR 3,5x1
CGPT-63	G1/8	M5	OR 5,28x1,78
CGPT-80	G1/8	M5	OR 5,28x1,78

Example of use of the pressurization/lubrication hole

Example of use of the lubrication (greasing) or pressurization hole of the zone with moving items

NOTE 1: grease the sliding zones using Molykote DX grease.

NOTE 2: supply a pressure of max. 3 bar in order to avoid the sudden ejection of grease.

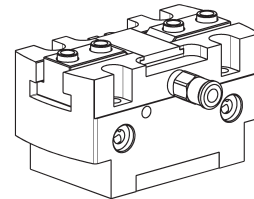
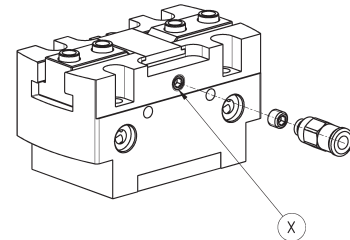

Mod.	X
CGPT-16	M3
CGPT-20	M5
CGPT-25	M5
CGPT-32	M5
CGPT-40	M5
CGPT-50	M5
CGPT-63	M5
CGPT-80	M5

Example of mounting: sensors

L = sensor mod. CSD-D-334 or mod. CSD-D-364

In order to position the sensor correctly, a channel must be created in the base.

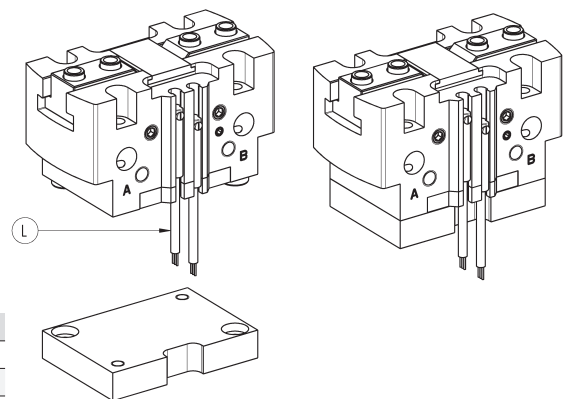

Mod.	L
CGPT-16	CSD...
CGPT-20	CSD...
CGPT-25	CSD...
CGPT-32	CSD...
CGPT-40	CSD...
CGPT-50	CSD...
CGPT-63	CSD...
CGPT-80	CSD...

Inductive sensor kit



- 2x fixing screws
- 1x blocking screw
- 1x plate

* use 1.5mm Allen key to adjust the reading position of the inductive sensor.

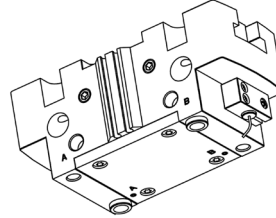
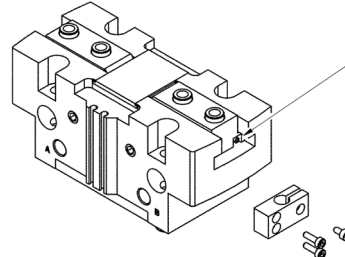

1 inductive sensor kit allows the use of a standard M8 inductive sensor.

Mod.	
CGPT-50	P-CGPT
CGPT-63	P-CGPT
CGPT-80	P-CGPT

Series CSD magnetic proximity switches, 3-wire cable, D-slot

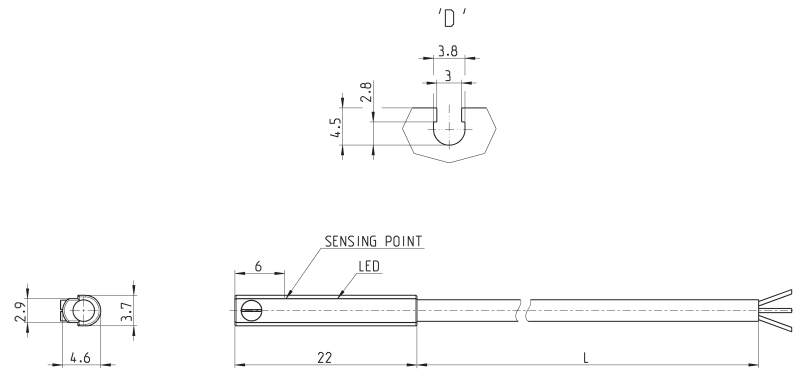

Mod.	Operation	Connections	Voltage	Output	Max. current	Max Load	Protection	L = length cable
CSD-D-334	Magnetoresistive	3 wires	10 ÷ 27 V DC	PNP	200 mA	6W	Against polarity reversing and overvoltage	2 m

Series CSD magnetic switches, male M8 3-pin conn., D-slot, right

Length of cable 0.3 metres

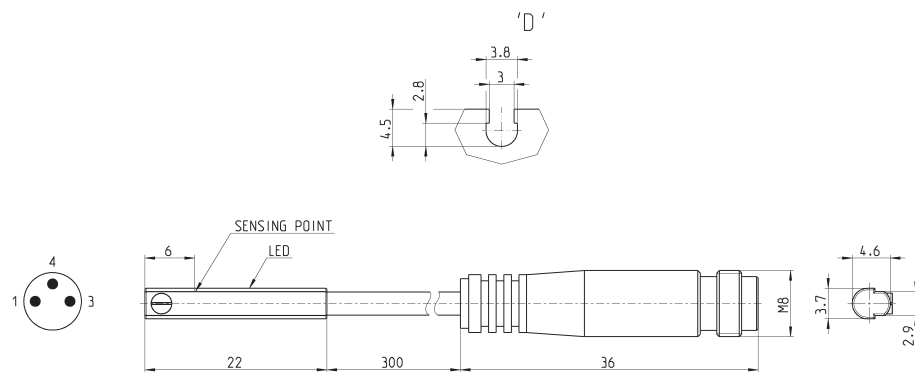

Mod.	Operation	Connection	Voltage	Output	Max. current	Max load	Protection
CSD-D-364	Magnetoresistive	3 wires with M8 connector	10 ÷ 27 V DC	PNP	200 mA	6W	Against polarity reversing and overvoltage