

MAGNETIC PROXIMITY SWITCHES

SERIES CSN

Reed switch



The electrical proximity switch Mod. CSN 2032-0 consists of a Reed switch complete with an electronic protection circuit and a red LED indicator.

The resin inside the casing ensures high protection and insulation.

It is designed so that it can be fixed directly on the tie-rod by means of two screws which assure the position longitudinal to the cylinder axle; and with a third screw for the anti-rotation positioning.

The three terminals are indicated by the numbers 1, 2 and 3 and enable the following connections to be made (see the scheme).

General Data

Mod.	CSN 2032-0
Voltage	From 12 to 220V AC and DC
Protection	IP54 / IP65 with connector DIN 43650
Material	Glass-reinforced PA
Mounting	Bracket for tie rod $\varnothing 6 + \varnothing 10$
Signalling	Integrated red LED
Electrical connection	DIN 43650 connector, Mod. 122-800
Max current	1.5 A
Max load	20 W DC - 30 VA AC
Actuating time	≤ 2 ms
Actuating tolerance	± 1 mm
Operating temperature	$-25^{\circ}\text{C} \div +75^{\circ}\text{C}$
Contact	NO (normally open)

Maximum loads and Connection

Maximum loads

For maximum loads see relative diagram, those loads are valid only for inductive loads. For capacitive loads, using clamp 3 (or black wire) load must not exceed 80 mA and load must be given by PLC or, for electrical circuits, by microrelay or micro solenoid valves with 2W maximum consumption.

When operating with direct current, clamp 1 must always be connected to the positive outlet (+).

In cases where commands are given from the PLC and logic NPN, clamp 1 must be connected to the inlet. In cases where commands are given from the PLC and logic PNP, clamps 2 or 3 must be connected to the inlet.

Connection

- For inductive loads = solenoid valves, electrical magnets, relay.
- For capacitive loads = circuit with remaining tension (see PLC controls)
- Note: For connections with wires of approximately 10m, the connection shall be made as for a capacitive load.

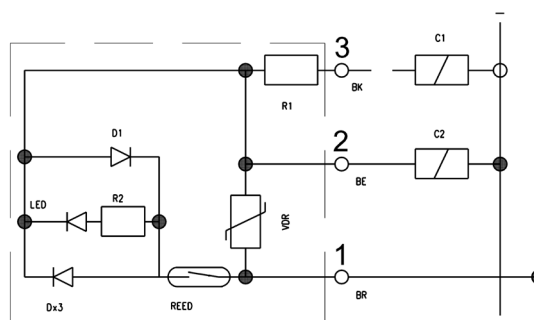

LEGEND:
 C1 = Capacitive load
 C2 = Inductive load

Maximum contact load

The maximum load (W) which the contacts are able to tolerate is that indicated in the section "General data", i.e.

- 20 W for direct current (DC)
- 30 VA for alternating current (AC)

The effective load allowed depends on the operating voltage (minimum 12 V, maximum 220 V) as shown in the following graph.

Note:

This graph was obtained from practical tests performed using a load consisting of our Series A and 6 solenoid valves, at an operating speed of one stroke per second.

For higher operating speeds, your are advised to contact our technical department.

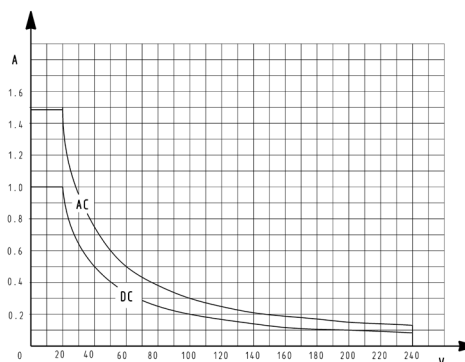

Switches - Series CSN

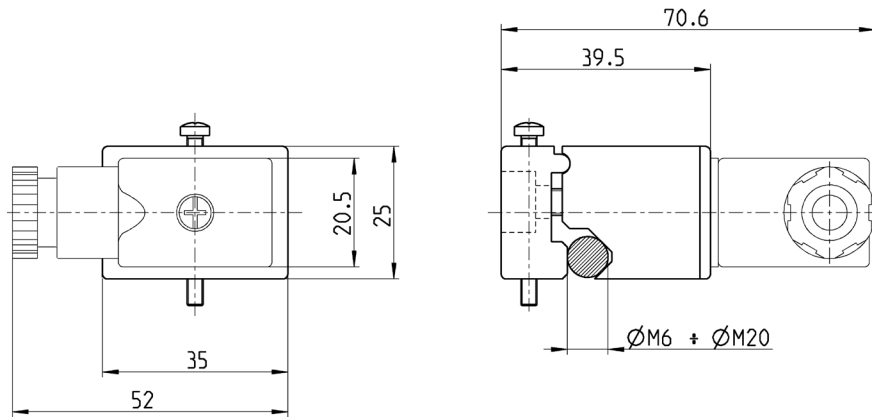

Mod.	For cylinders Series 40 - Ø 160 ÷ 200	For cylinders Series 40 - Ø 250 ÷ 320	For cylinders Series 41 - Ø 160 ÷ 200
CSN 2032-0	mounting band to be ordered separately	direct mounting	mounting band to be ordered separately

Adapter Mod. S53 for CSN proximity switch



Material:
aluminium

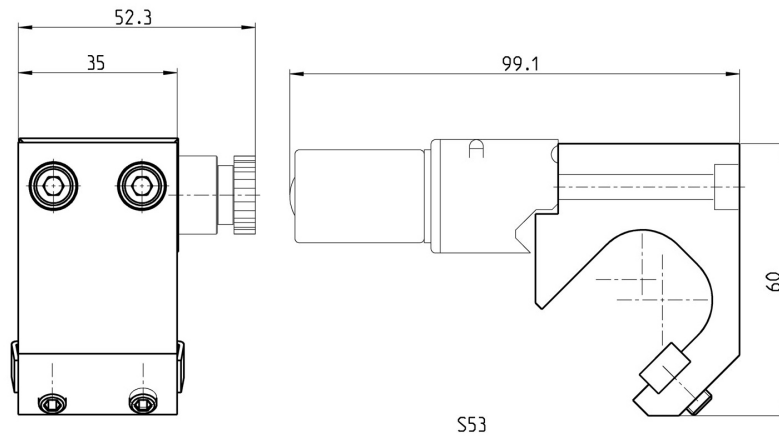

Mod.	Series	Ø
S53	41K	160-200

Adapter Mod. S21 for CSN proximity switch



Material:
aluminium

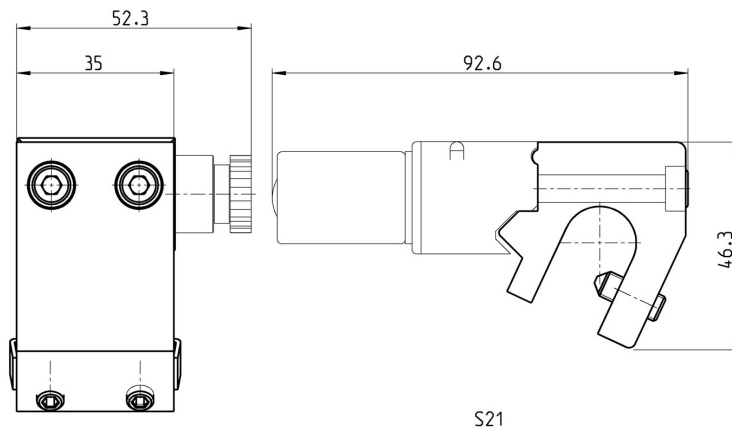

Mod.	Series	Ø
S21	40K	160-200

Connectors with cable

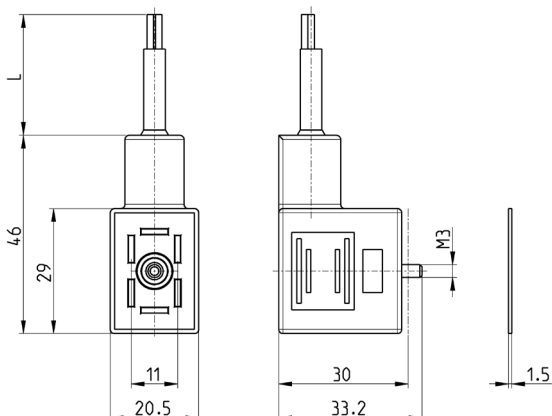

Mod.	Description	Colour	Working voltage	Cable length [L]	Cable gland	Tightening torque
122-550-1	Moulded cable, without electronics	Black	-	1000 mm	-	0,5 Nm
122-550-5	Moulded cable, without electronics	Black	-	1000 mm	-	0,5 Nm

Connectors

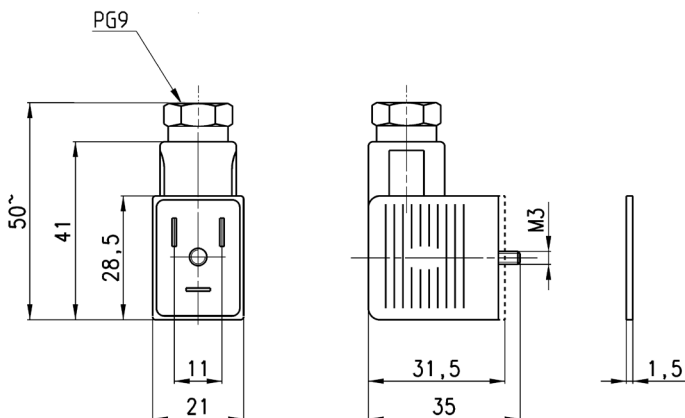

Mod.	Description	Colour	Working voltage	Cable gland	Tightening torque
122-800	Connector, without electronics	Black	-	PG9	0,5 Nm