

Zylinder ISO 15552 Serie 63

Neue Versionen

Alu-Profil/-Rundrohr, einfach-/doppeltwirkend,
Magnetversion, Endlagendämpfung, zahlreiche Versionen
ø 32, 40, 50, 63, 80, 100, 125 mm



Die Zylinder der Serie 63 nach ISO 15552 vereinen hohe Leistungsfähigkeit mit universellen Einsatzmöglichkeiten. Sie verfügen über ein neues System einstellbarer Endlagendämpfungen und erzielen so eine feine Einstellmöglichkeit sowie eine signifikante Geräuschreduzierung beim Erreichen der Endlage.

Zusätzlich zur Standardversion mit Einsatzmöglichkeiten in den unterschiedlichsten Branchen wurden Versionen für spezifische Anwendungen in der Lebensmittelindustrie, Landwirtschaft, für Tänzerwalzen-Steuerungen oder Dosiersysteme entwickelt. Weitere Versionen sind für den Einsatz in anspruchsvollen Umgebungen mit hohen Anforderungen in Bezug auf Temperaturen, Korrosion oder Sicherheit geeignet.

- » ISO 15552 konform
- » Gewichtsreduziert um 25 %
- » Geräuscharm
- » Fein einstellbare Endlagendämpfung
- » Universell einsetzbar

VERSIONEN:

- » Leichtlauf
- » Gleichlauf
- » Hoch-/Tieftemperatur
- » Korrosionsbeständig
- » Hydrolysebeständig
- » Lebensmittelkonform
- » Ohne Schmierung
- » Verschmutzte und staubige Umgebungen
- » Kolbenstange mit Faltenbalg
- » Boden/Boden-Montage
- » Tandem- und Mehrstellungsversion
- » mit Feststelleinheit
- » PU-Beschichtung
- » ATEX zertifiziert

ALLGEMEINE KENNGRÖSSEN

Bauart	Alu-Profil/-Rundrohr mit Zugankern
Norm	ISO 15552
Funktion	Einfach-, doppeltwirkend
Befestigungsart	Fußbefestigung, Schwenkgabel vorn/hinten, Schwenklager sphärisch, Mittelschwenklager
Hub min - max	10 ÷ 2500 mm
Betriebstemperatur	Standard-, Leichtlaufversion: 0°C ÷ 80°C (mit getrockneter Luft bis -20°C) Hochtemperaturversion (Version W): 0°C ÷ 150°C (mit getrockneter Luft bis -20°C) Tieftemperaturversion (Version Z): -40°C ÷ 60°C Tieftemperaturversion (Version Y): -50°C ÷ 60°C
Lagertemperatur	0°C ÷ 80°C (mit getrockneter Luft bis -20°C)
Betriebsdruck	1 ÷ 10 bar (Standard, Tief- und Hochtemperatur) 0,1 ÷ 10 bar (Leichtlaufversion)
Geschwindigkeit	10 ÷ 1000 mm/sec, ohne Last (Standard, Hoch- und Tieftemperatur) 5 ÷ 1000 mm/sec, ohne Last (Leichtlaufversion)
Medium	Gefilterte Luft Klasse 7.8.4, gemäß ISO 8573-1. Im Falle von geölter Luft empfehlen wir die Verwendung von Öl ISO VG 32 und die Schmierung nie zu unterbrechen.
Schaltelemente	63MP: Mod. CSH, 63MT: Mod. CSH/CST + Mod. S-CST...

STANDARDHÜBE ZYLINDER SERIE 63

■ = einfachwirkend, Feder vorn (Standard, Hoch temperatur Version); ▲ = einfachwirkend, Feder hinten (Standard, Hoch temperatur);
 ✕ = doppeltwirkend (Standard-, Leichtlauf-, Hoch-/Tieftemperaturversion); auf Anfrage Hübe bis max. 2500 mm

STANDARDHÜBE		25	50	75	80	100	125	150	160	200	250	300	320	400	500
Ø															
32	■ ▲ ✕	■ ▲ ✕	■ ✕	✕	✕	✕	✕	✕	✕	✕	✕	✕	✕	✕	✕
40	■ ▲ ✕	■ ▲ ✕	■ ✕	✕	✕	✕	✕	✕	✕	✕	✕	✕	✕	✕	✕
50	■ ▲ ✕	■ ▲ ✕	■ ✕	✕	✕	✕	✕	✕	✕	✕	✕	✕	✕	✕	✕
63	■ ▲ ✕	■ ▲ ✕	■ ✕	✕	✕	✕	✕	✕	✕	✕	✕	✕	✕	✕	✕
80	■ ▲ ✕	■ ▲ ✕	■ ✕	✕	✕	✕	✕	✕	✕	✕	✕	✕	✕	✕	✕
100		■ ▲ ✕	■ ✕	✕	✕	✕	✕	✕	✕	✕	✕	✕	✕	✕	✕
125		■ ▲ ✕	■ ✕	✕	✕	✕	✕	✕	✕	✕	✕	✕	✕	✕	✕

MODELLBEZEICHNUNG

63	M	P	2	C	050	A	0200	W							
-----------	----------	----------	----------	----------	------------	----------	-------------	----------	--	--	--	--	--	--	--

63	SERIE	
M	BAUREIHE M = Standard, Magnetversion V = Gleichlaufversion (ohne stick slip), magnetisch L = Leichtlaufversion, magnetisch	
P	BAUART T = Rundrohr P = Profilrohr	
2	BETRIEBSART 1 = Einfachwirkend, Feder vorn 2 = Doppeltwirkend 6 = Doppeltwirkend, durchgehende Kolbenstange 7 = Einfachwirkend, durchgehende Kolbenstange 9 = Einfachwirkend, Feder hinten	PNEUMATIKSYMBOLE CS07/CS18 CD08 - CD09 - CD10 - CD11 CD13 CS11 CS14/CS17
C	ENDLAGENDÄMPFUNG N = Nicht gedämpft C = Beidseitig gedämpft F = Vorne gedämpft R = Hinten gedämpft	PNEUMATIKSYMBOLE CD08 CD09/CD13 CD11 CD10
050	KOLBENDURCHMESSER 032 = 32 mm 040 = 40 mm 050 = 50 mm 063 = 63 mm	080 = 80 mm 100 = 100 mm 125 = 125 mm
A	BEFESTIGUNGSART A = Standard, montiert mit Kolbenstangenmutter U RL = Zylinder mit Feststelleinheit	DC = Boden/Boden-Montage mit Mod. DC-63...[X1/X2] TR = Boden/Boden-Montage für Rundrohr [X1/X2] F = Zylinder mit Mittelschwenklager (nur bei Rundrohr)
0200	HÜBE = Standard N = Tandem / = Mehrstellung X1/X2 [X1 < X2]	
W	TEMPERATURBEREICHE = Standard W = Hochtemperaturversion (150°C)	Z = Tieftemperaturversion (-40°C) Y = Tieftemperaturversion (-50°C)
	KORROSIONSBESTÄNDIGKEIT = Standard C1 = Kolbenstangenmutter, Kolbenstange Edelstahl 1.4301 C2 = Kopfschrauben oberflächenveredelt (Profil), Zugstangenmutter 1.4305, Zuganker 1.4028 (Rundrohr)	C3 = C2 + Kolbenstange/Mutter 1.4401 C4 = C1 + C2 C5 = C3 + Zylinderkopf mit 3-fach Schutz
	VERSIONEN = Standard (Kolbenstange mit Außengewinde) F = Kolbenstange mit Innengewinde K = Kopf/Deckel Kanigen-Beschichtung L = Ohne Kolbenstangendichtung (nur Leichtlaufversion) V = Kolbenstangendichtung in FKM R = Kolbenstangendichtung in NBR U = Ohne Schmierung	H = Hydrolyse-Beständigkeit A = für Anwendungen im Lebensmittel- und Hygienebereich G = Trockene und staubige Umgebungen (Abstreifer in Messing, Kolbenstange 1.4028 verchromt) B = Kolbenstange mit Faltenbalg / NBR (___) = Kolbenstange verlängert um ___ mm
	SONSTIGES P = PU lackiert RAL 7035	

ZYLINDER ISO 15552 SERIE 63

PNEUMATIKSYMBOLS

Pneumatiksymbole entsprechend der Modellbezeichnung.

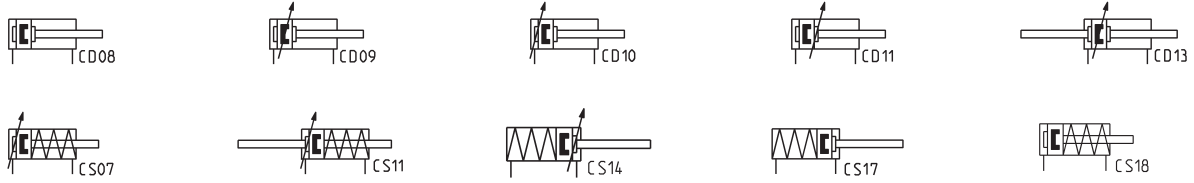

BESCHREIBUNG DER BAUTEILE

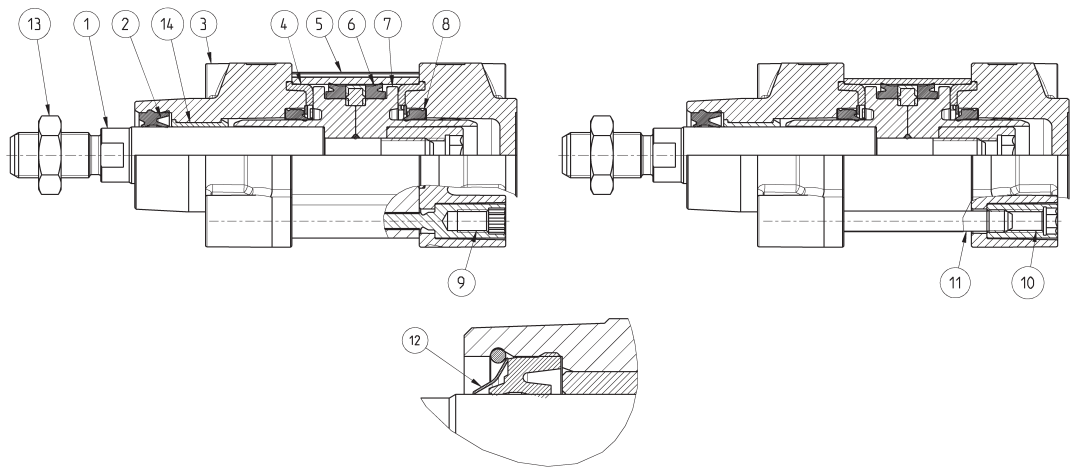

BESCHREIBUNG DER BAUTEILE							
BAUTEILE	Standard, Profilrohr	Standard, Rundrohr	Leichtlauf (L)	Abstreifer (G)	Tieftemperatur (Z/Y)	Hochtemperatur (W)	Korrosionsbeständig (C1)
1 - Kolbenstange	Edelstahl Werkstoff 1.4028	Edelstahl Werkstoff 1.4028	Edelstahl Werkstoff 1.4028	Edelstahl Werkstoff 1.4028 verchromt	Edelstahl Werkstoff 1.4028 verchromt	Edelstahl Werkstoff 1.4028	Edelstahl Werkstoff 1.4301
2 - Kolbenstangendichtung	PU	PU	NBR	NBR	PU für -40°C / -50°C	FKM	PU
3 - Deckel	Aluminium	Aluminium	Aluminium	Aluminium	Aluminium	Aluminium	Aluminium
4 - Anschlagdichtung	NBR	NBR	NBR	NBR	NBR für -40°C / -50°C	FKM	NBR
5 - Strangprofil	Aluminium eloxiert	Aluminium eloxiert	Aluminium eloxiert	Aluminium eloxiert	Aluminium eloxiert	Aluminium eloxiert	Aluminium eloxiert
6 - Kolbendichtung	PU	PU	NBR	PU	PU für -40°C / -50°C	FKM	PU
7 - Kolben	Kunststoff (ø 32 mm) oder Aluminium (ø 40 ÷ 125 mm)	Aluminium (ø 125 mm) oder Kunststoff (ø 32 ÷ 100 mm)	Aluminium	Aluminium	Aluminium	Aluminium	Aluminium
8 - Endlagendämpfungsichtung	PU	PU	PU	PU	PU	FKM	PU
9 - Zugankerschraube	Stahl verzinkt	-	Stahl verzinkt	Stahl verzinkt	Stahl verzinkt	Stahl verzinkt	Stahl verzinkt
10 - Zugankermutter	-	Stahl verzinkt	Stahl verzinkt	Stahl verzinkt	Edelstahl Werkstoff 1.4305	Stahl verzinkt	Stahl verzinkt
11 - Zuganker	-	Stahl verzinkt	Stahl verzinkt	Stahl verzinkt	Edelstahl Werkstoff 1.4028	Stahl verzinkt	Stahl verzinkt
12 - Abstreifer	-	-	-	Messing	Messing	-	-
13 - Kolbenstangenmutter	Stahl verzinkt	Stahl verzinkt	Stahl verzinkt	Stahl verzinkt	Edelstahl Werkstoff 1.4305	Stahl verzinkt	Edelstahl Werkstoff 1.4301
14 - Kolbenstangenführungsbuchse	Kunststoff	Kunststoff	Kunststoff	Kunststoff	Kunststoff	Stahl+PTFE	Kunststoff

Modell- und Maßänderungen vorbehalten. Unsere AGBs finden Sie auf www.camozzi.de.

Zylinder Serie 63 Leichtlaufversion - Anwendungsbeispiele

ZYLINDER ISO 15552 SERIE 63

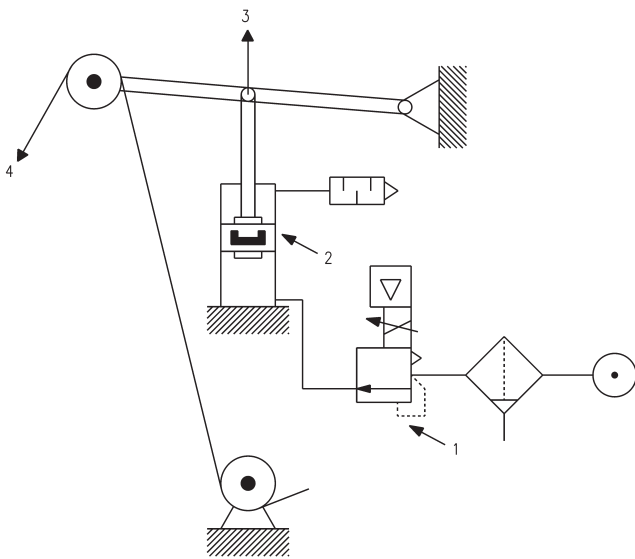

ZYLINDER AUSFAHREND

1. Präzisionsregler / Proportionalregler
2. Leichtlaufzylinder
3. Kraftrichtung
4. Seil/Band/Zahnriemen etc.

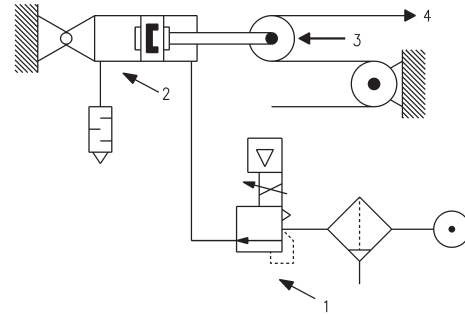

ZYLINDER EINFAHREND

Um optimalen Leichtlauf zu erreichen, empfiehlt sich der Einsatz eines Präzisionsdruckreglers oder eines Proportionalreglers (siehe Skizze).

SERIE 63 - ZUBEHÖR



Ausgleichskupplung
Mod. GY



Kolbenstangenmutter
Mod. U



Lagerbolzen Mod. S



Schwenklager sphärisch
Mod. R



Ausgleichsflansch
Mod. GKF



Gelenkauge Mod. GA

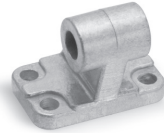

Lagerbock 90° mit starrem
Lager Mod. ZC



Kombination Mod. C, L, S



Flansch vorn und hinten
Mod. D-E



Ausgleichskupplung
Mod. GK



Mittelschwenklager
Mod. F-63



Fußbefestigung
Mod. B-41



Schwenkgabel vorne
Mod. H und C-H



Schwenkgabel hinten
Mod. C und C-H

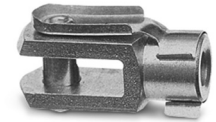

Gabelkopf Mod. G

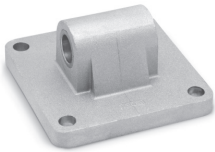

Schwenklager hinten
Mod. L



Demontagewerkzeug f.
Zylinder Ø 80 +100mm

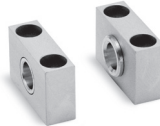

Lagerbock Mod. BF



Mittelschwenklager vorne
Mod. FN



Mehrstellungsbausatz
Mod. DC-63



Mittelschwenklager
Mod. F



Montiert mit Kolbenstangenmutter U.

Zylinder Serie 63 - Profilrohr doppelwirkend

Versionen: 63MP2..., 63LP2... und 63VP2...

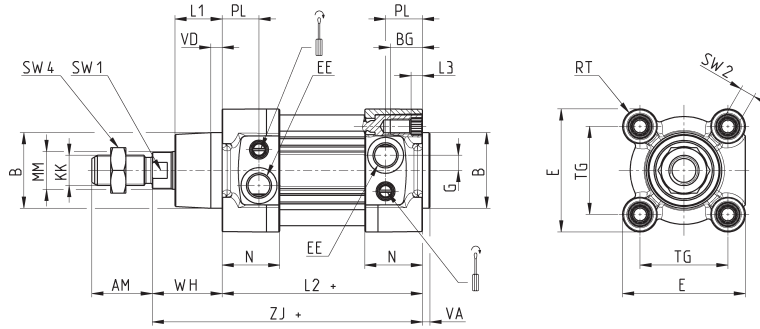

+ Hub

PRODUKTÜBERSICHT																									
Ø	ØMM	KK	ØB	PL	L1	AM	VA	EE	WH	L2+	L3	ZJ+	VD	N	BG	RT	G	TG	E	SW1	SW2	SW4	Dämpfungshub vorn/hinten		
32	12	M10x1.25	30	18.5	18	22	4	G1/8	26	94	5.5	120	5	27	16	M6	5	32.5	47	10	6	17	17		
40	16	M12x1.25	35	19	21	24	4	G1/4	30	105	5.5	135	5	30	16	M6	5	38	55	13	6	19	18		
50	20	M16x1.5	40	19.5	25	32	4	G1/4	37	106	6	143	6	30.5	16	M8	8	46.5	65	17	8	24	20		
63	20	M16x1.5	45	24	26	32	4	G3/8	37	121	6	158	6	37.5	16	M8	8	56.5	75	17	8	24	22		
80	25	M20x1.5	45	23.5	30	40	4	G3/8	46	128	0	174	7	37	19	M10	8	72	93	22	6	30	25		
100	25	M20x1.5	55	24	35	40	4	G1/2	51	138	0	189	7	39.5	19.5	M10	8	89	110	22	6	30	26		
125	32	M27x2	60	28	42	54	6	G1/2	65	160	6	225	8	44	23	M12	10.5	110	135	27	12	41	33		

Zylinder Serie 63 - Rundrohr doppelwirkend

Versionen: 63MT2..., 63LT2... und 63VT2...

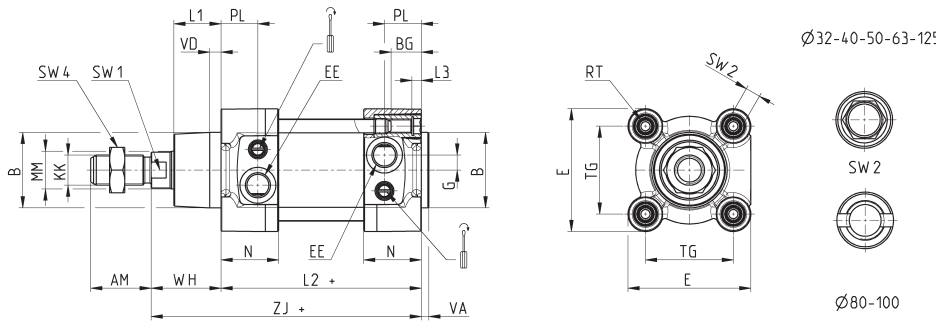

+ Hub

Hinweis zur Tabelle
* = Demontagewerkzeug 80-62/8C (siehe Zubehör)

PRODUKTÜBERSICHT																									
Ø	ØMM	KK	ØB	PL	L1	AM	VA	EE	WH	L2+	L3	ZJ+	VD	N	BG	RT	G	TG	E	SW1	SW2	SW4	Dämpfungshub vorn/hinten		
32	12	M10x1.25	30	18.5	18	22	4	G1/8	26	94	5.5	120	5	27	16	M6	5	32.5	47	10	6	17	17		
40	16	M12x1.25	35	19	21	24	4	G1/4	30	105	5.5	135	5	30	16	M6	5	38	55	13	6	19	18		
50	20	M16x1.5	40	19.5	25	32	4	G1/4	37	106	6	143	6	30.5	16	M8	8	46.5	65	17	8	24	20		
63	20	M16x1.5	45	24	26	32	4	G3/8	37	121	5	158	6	37.5	16	M8	8	56.5	75	17	8	24	22		
80	25	M20x1.5	45	23.5	30	40	4	G3/8	46	128	0	174	7	37	19	M10	8	72	93	22	*	30	25		
100	25	M20x1.5	55	24	35	40	4	G1/2	51	138	0	189	7	39.5	19.5	M10	8	89	110	22	*	30	26		
125	32	M27x2	60	28	42	54	6	G1/2	65	160	6	225	8	44	23	M12	10.5	110	135	27	12	41	33		

Zylinder Serie 63 - Profilrohr einfachwirkend, Feder vorne

Versionen: 63MP1...



+ Hub

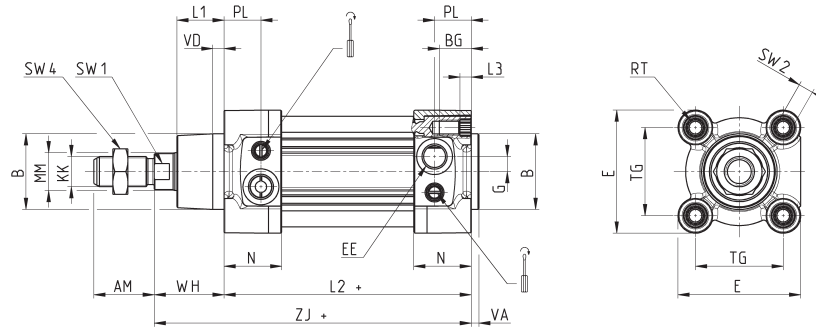

PRODUKTÜBERSICHT																									
Ø	ØMM	KK	ØB	PL	L1	AM	VA	EE	WH	L2+	L3	ZJ+	VD	N	BG	RT	G	TG	E	SW1	SW2	SW4	Dämpfungshub vorn/hinten		
32	12	M10x1.25	30	18.5	18	22	4	G1/8	26	119	5.5	145	5	27	16	M6	5	32.5	47	10	6	17	17		
40	16	M12x1.25	35	19	21	24	4	G1/4	30	130	5.5	160	5	30	16	M6	5	38	55	13	6	19	18		
50	20	M16x1.5	40	19.5	25	32	4	G1/4	37	131	6	168	6	30.5	16	M8	8	46.5	65	17	8	24	20		
63	20	M16x1.5	45	24	26	32	4	G3/8	37	146	6	183	6	37.5	16	M8	8	56.5	75	17	8	24	22		
80	25	M20x1.5	45	23.5	30	40	4	G3/8	46	153	0	199	7	37	19	M10	8	72	93	22	6	30	25		
100	25	M20x1.5	55	24	35	40	4	G1/2	51	163	0	214	7	39.5	19.5	M10	8	89	110	22	6	30	26		
125	32	M27x2	60	28	42	54	6	G1/2	65	185	6	250	8	44	23	M12	10.5	110	135	27	12	41	33		

Zylinder Serie 63 - Profilrohr einfachwirkend, Feder hinten

Versionen: 63MP9...



+ Hub
++ = 2x Hub

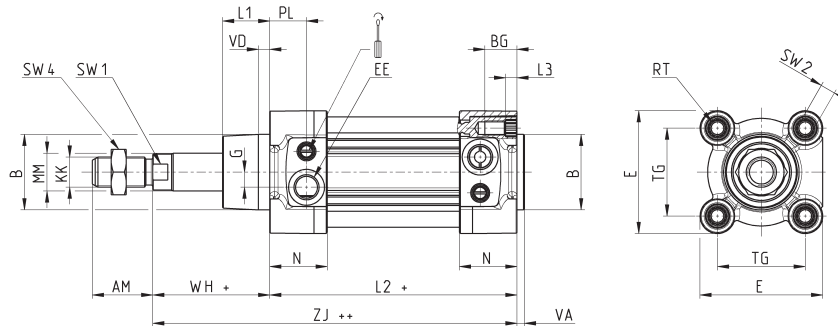

PRODUKTÜBERSICHT																									
Ø	ØMM	KK	ØB	PL	L1	AM	VA	EE	WH+	L2+	L3	ZJ++	VD	N	BG	RT	G	TG	E	SW1	SW2	SW4	Dämpfungshub vorn/hinten		
32	12	M10x1.25	30	18.5	18	22	4	G1/8	51	119	5.5	170	5	27	16	M6	5	32.5	47	10	6	17	17		
40	16	M12x1.25	35	19	21	24	4	G1/4	55	130	5.5	185	5	30	16	M6	5	38	55	13	6	19	18		
50	20	M16x1.5	40	19.5	25	32	4	G1/4	62	131	6	193	6	30.5	16	M8	8	46.5	65	17	8	24	20		
63	20	M16x1.5	45	24	26	32	4	G3/8	62	146	6	208	6	37.5	16	M8	8	56.5	75	17	8	24	22		
80	25	M20x1.5	45	23.5	30	40	4	G3/8	71	153	0	224	0	37	19	M10	8	72	93	22	6	30	25		
100	25	M20x1.5	55	24	35	40	4	G1/2	76	163	0	239	0	39.5	19.5	M10	8	89	110	22	6	30	26		
125	35	M27x2	60	28	42	54	6	G1/2	90	185	6	275	6	44	23	M12	10.5	110	135	27	12	41	33		

Zylinder Serie 63 - Rundrohr einfachwirkend, Feder vorne

Versionen: 63MT1...

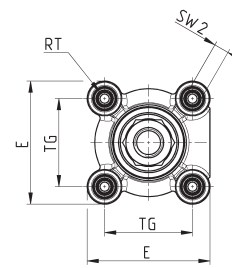
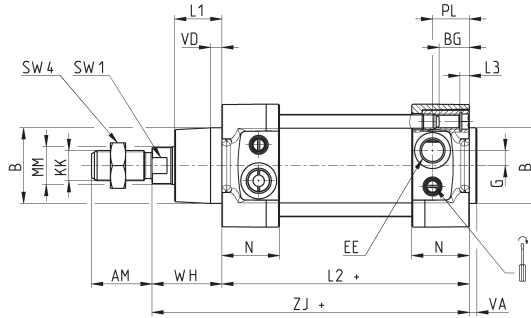

Ø32-40-50-63-125



Ø80-100

+ Hub

Hinweis zur Tabelle
* = Demontagewerkzeug 80-62/8C (siehe Zubehör)

PRODUKTÜBERSICHT

Ø	ØMM	KK	ØB	PL	L1	AM	VA	EE	WH	L2+	L3	ZJ+	VD	N	BG	RT	G	TG	E	SW1	SW2	SW4	Dämpfungshub vorn/hinten
32	12	M10x1.25	30	18.5	18	22	4	G1/8	26	119	5	145	5	27	16	M6	5	32.5	47	10	6	17	17
40	16	M12x1.25	35	19	21	24	4	G1/4	30	130	5	160	5	30	16	M6	5	38	55	13	6	19	18
50	20	M16x1.5	40	19.5	25	32	4	G1/4	37	131	5	168	6	30.5	16	M8	8	46.5	65	17	8	24	20
63	20	M16x1.5	45	24	26	32	4	G3/8	37	146	5	183	6	37.5	16	M8	8	56.5	75	17	8	24	22
80	25	M20x1.5	45	23.5	30	40	4	G3/8	46	153	0	199	7	37	19	M10	8	72	93	22	*	30	25
100	25	M20x1.5	55	24	35	40	4	G1/2	51	163	0	214	7	39.5	19.5	M10	8	89	110	22	*	30	26
125	32	M27x2	60	28	42	54	6	G1/2	65	185	6	250	8	44	23	M12	10.5	110	135	27	12	41	33

Zylinder Serie 63 - Rundrohr einfachwirkend, Feder hinten

Versionen: 63MT9...

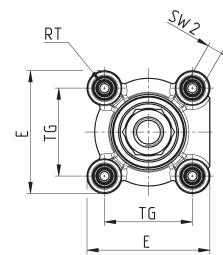
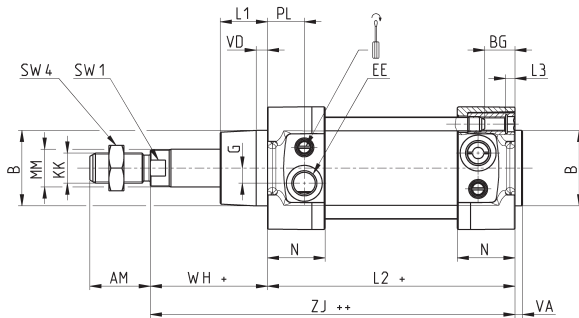

Ø32-40-50-63-125



Ø80-100

+ Hub

Hinweis zur Tabelle
* = Demontagewerkzeug 80-62/8C (siehe Zubehör)

PRODUKTÜBERSICHT

Ø	ØMM	KK	ØB	PL	L1	AM	VA	EE	WH+	L2+	L3	ZJ++	VD	N	BG	RT	G	TG	E	SW1	SW2	SW4	Dämpfungshub vorn/hinten
32	12	M10x1.25	30	18.5	18	22	4	G1/8	51	119	5	170	5	27	16	M6	5	32.5	47	10	6	17	17
40	16	M12x1.25	35	19	21	24	4	G1/4	55	130	5	185	5	30	16	M6	5	38	55	13	6	19	18
50	20	M16x1.5	40	19.5	25	32	4	G1/4	62	131	5	193	6	30.5	16	M8	8	46.5	65	17	8	24	20
63	20	M16x1.5	45	24	26	32	4	G3/8	62	146	5	208	6	37.5	16	M8	8	56.5	75	17	8	24	22
80	25	M20x1.5	45	23.5	30	40	4	G3/8	71	153	0	224	7	37	19	M10	8	72	93	22	*	30	25
100	25	M20x1.5	55	24	35	40	4	G1/2	76	163	0	239	7	39.5	19.5	M10	8	89	110	22	*	30	26
125	35	M27x2	60	28	42	54	6	G1/2	90	185	6	275	8	44	23	M12	10.5	110	135	27	12	41	33

Zylinder Serie 63 - Profilrohr, durchgehende Kolbenstange

Versionen: 63MP6... und 63MP7...

Hinweis: Die Abmessungen L2 und ZM der einfachwirkenden Version erhöhen sich um 25 mm

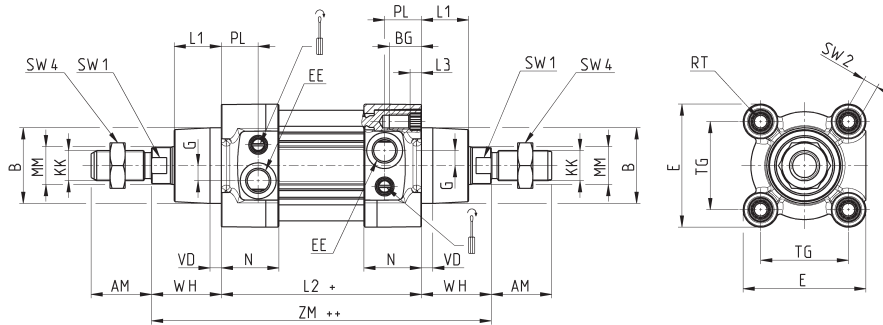

+ Hub
++ 2 x Hub

Ø	ØMM	KK	ØB	PL	L1	AM	EE	WH	L2+	L3	ZM++	VD	N	BG	RT	G	TG	E	ØF	SW1	SW2	SW4	
32	12	M10x1.25	30	18.5	18	22	G1/8	26	94	5.5	146	5	27	16	M6	5	32.5	47	-	10	6	17	17
40	16	M12x1.25	35	19	21	24	G1/4	30	105	5.5	165	5	30	16	M6	5	38	55	-	13	6	19	18
50	20	M16x1.5	40	19.5	25	32	G1/4	37	106	6	180	6	30.5	16	M8	8	46.5	65	8	17	8	24	20
63	20	M16x1.5	45	24	26	32	G3/8	37	121	6	195	6	37.5	16	M8	8	56.5	75	8	17	8	24	22
80	25	M20x1.5	45	23.5	30	40	G3/8	46	128	7	220	7	37	19	M10	8	72	93	8	22	6	30	25
100	25	M20x1.5	55	24	35	40	G1/2	51	138	7	240	7	39.5	19.5	M10	8	89	110	8	22	6	30	26
125	32	M27x2	60	28	42	54	G1/2	65	160	8	290	8	44	23	M12	10.5	110	135	-	27	12	41	33

Zylinder Serie 63 - Rundrohr, durchgehende Kolbenstange

Versionen: 63MT6... und 63MT7...

Hinweis: Die Abmessungen L2 und ZM der einfachwirkenden Version erhöhen sich um 25 mm

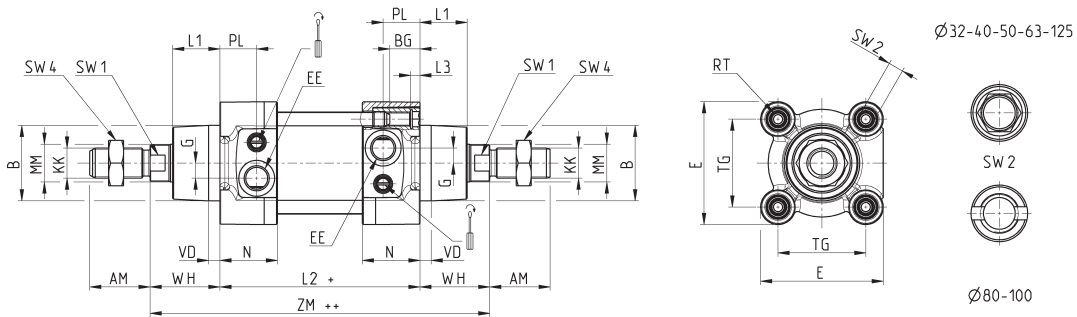

+ Hub
++ 2x Hub

Hinweis zur Tabelle
* = Demontagewerkzeug 80-62/8C (siehe Zubehör)

Ø	ØMM	KK	ØB	PL	L1	AM	EE	WH	L2+	L3	ZM++	VD	N	BG	RT	G	TG	E	ØF	SW1	SW2	SW4	
32	12	M10x1.25	30	18.5	18	22	G1/8	26	94	5	146	5	27	16	M6	5	32.5	47	-	10	6	17	17
40	16	M10x1.25	35	19	21	24	G1/4	30	105	5	165	5	30	16	M6	5	38	55	-	13	6	19	18
50	20	M16x1.5	40	19.5	25	32	G1/4	37	106	5	180	6	30.5	16	M8	8	46.5	65	8	17	8	24	20
63	20	M16x1.5	45	24	26	32	G3/8	37	121	5	195	6	37.5	16	M8	8	56.5	75	8	17	8	24	22
80	25	M20x1.5	45	23.5	30	40	G3/8	46	128	0	220	7	37	19	M10	8	72	93	8	22	*	30	25
100	25	M20x1.5	55	24	35	40	G1/2	51	138	0	240	7	39.5	19.5	M10	8	89	110	8	22	*	30	26
125	32	M27x2	60	28	42	54	G1/2	65	160	6	290	8	44	23	M12	10.5	110	135	-	27	12	41	33

Zylinder Serie 63 - mit Feststelleinheit

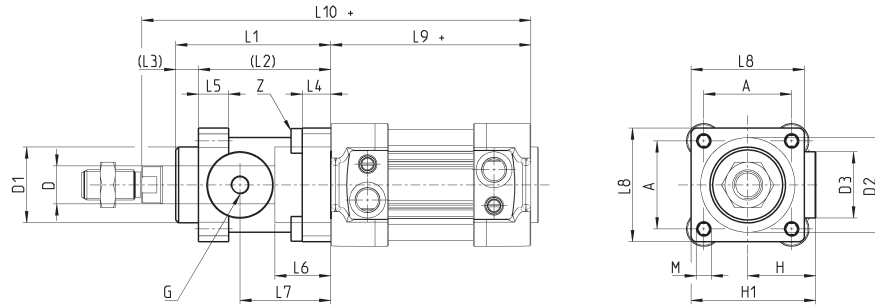

+ Hub

ZYLINDER ISO 15552 SERIE 63

∅	\varnothing_D	\varnothing_{D1}	\varnothing_{D2}	\varnothing_{D3}	A	G	H	H1	L1	L2	L3	L4	L5	L6	L7	L8	L9+	L10+	M	Z
32	12	30.5	35	25	32.5	M5	25.5	46.5	58	48	10	8	13	20.5	34	45	94	160	M6	M6X20
40	16	35	40	28	38	G1/8	30	53	65	55	10	8	13	22.5	38	50	105	178	M6	M6X20
50	20	40	50	35	46.5	G1/8	36	64	82	70	12	15	16	29.5	48	60	106	200	M8	M6X20
63	20	45	60	38	56.5	G1/8	40	75	82	70	12	15	16	29.5	49.5	70	121	215	M8	M8X30
80	25	45	80	48	72	G1/8	50	95	110	90	20	18	20	35	61	90	128	254	M10	M10X35
100	25	55	100	58	89	G1/8	58	110.5	115	100	15	18	20	39	69	105	138	269	M10	M10X35
125	32	60	130	65	110	G1/8	80	150	167	122	45	22	30	51	86.5	140	160	350	M12	M12X40

Zylinder Serie 63 - mit Kolbenstangen-Innengewinde

Neue Version

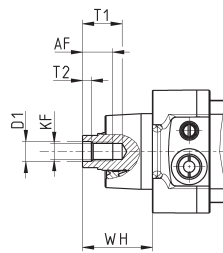

PRODUKTÜBERSICHT						
∅	AF Min	KF	D1 ∅	T1 Max	T2	WH
32	12	M6X1	6.4	16	2.6	26
40	12	M8X1.25	8.4	16	3.3	30
50	16	M10X1.5	10.5	21	4.7	37
63	16	M10X1.5	10.5	21	4.7	37
80	20	M12X1.75	13	26.5	6.1	46
100	20	M12X1.75	13	26.5	6.1	54
125	32	M16X2	17	40	8	65

Zylinder Serie 63 - Rundrohr, Tandemversion

Neue Version

+ Hub
++ 2x Hub

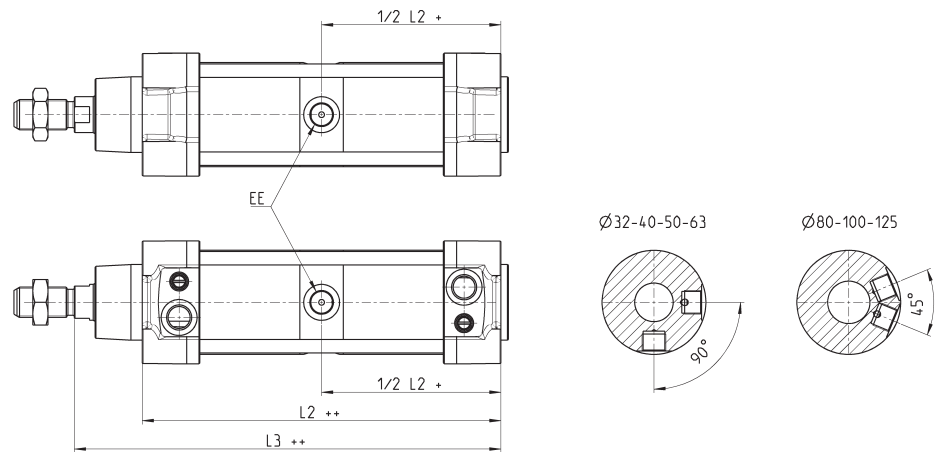

PRODUKTÜBERSICHT			
Ø	EE	L2 ++	L3 ++
32	G1/8	171.5	197.5
40	G1/4	191.5	221.5
50	G1/4	188	225
63	G3/8	204	241
80	G3/8	225.5	271.5
100	G1/2	231	282
125	G1/2	264	329

Zylinder Serie 63 - Profilrohr, Tandemversion

Neue Version

+ Hub
++ 2x Hub

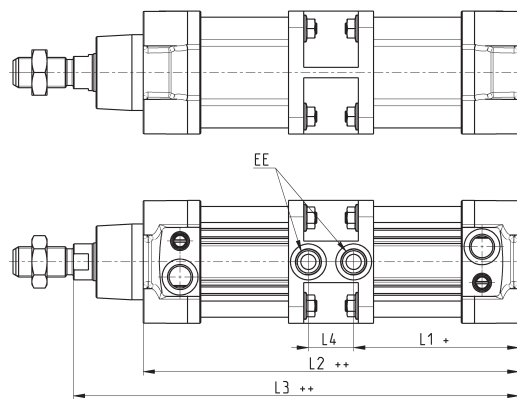

PRODUKTÜBERSICHT					
Ø	EE	L1+	L2++	L3++	L4
32	G1/8	76.5	171.5	197.5	18.5
40	G1/4	88.5	200	230	23
50	G1/4	87.5	199	236	24
63	G3/8	98	223	260	27
80	G3/8	104.5	236	282	27
100	G1/2	116	260	311	28
125	G1/2	132	264	329	0

Zylinder Serie 63 - Rundrohr, Mehrstellungsversion

Neue Version

ZYLINDER ISO 15552 SERIE 63

+ Hub
++ 2x Hub

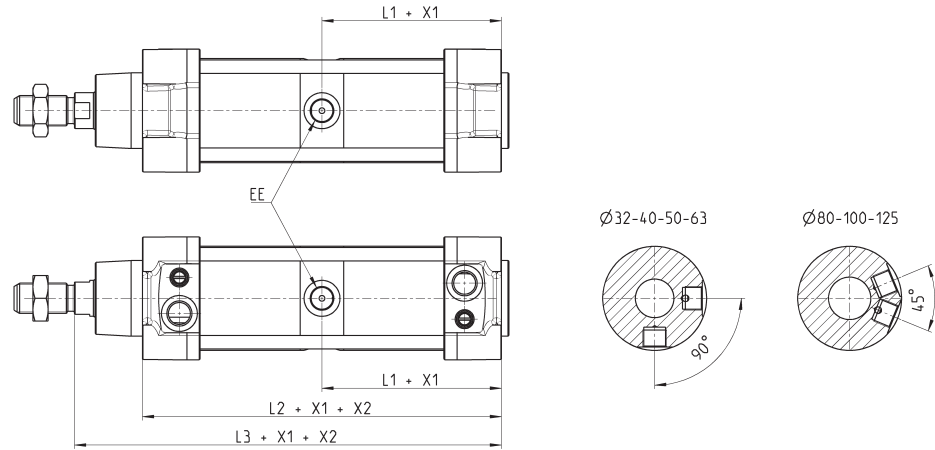

PRODUKTÜBERSICHT					
Ø	EE	L1	L2	L3	
32	G1/8	86	171.5	197.5	
40	G1/4	96	191.5	221.5	
50	G1/4	94	188	225	
63	G3/8	102	204	241	
80	G3/8	113	225.5	271.5	
100	G1/2	115.5	231	282	
125	G1/2	132	264	329	

Zylinder Serie 63 - Profilrohr, Mehrstellungsversion

Neue Version

+ Hub
++ 2x Hub

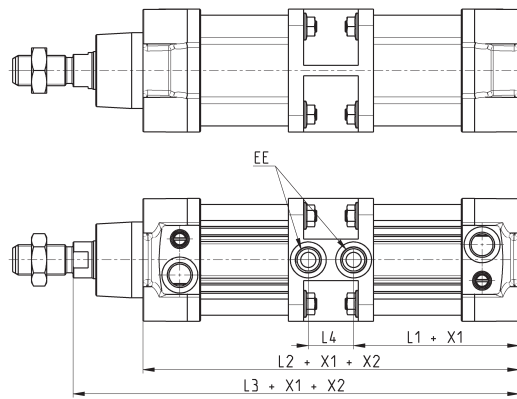

PRODUKTÜBERSICHT					
Ø	EE	L1+	L2++	L3++	L4
32	G1/8	76.5	171.5	197.5	18.5
40	G1/4	88.5	200	230	23
50	G1/4	87.5	199	236	24
63	G3/8	98	223	260	27
80	G3/8	104.5	236	282	27
100	G1/2	116	260	311	28
125	G1/2	132	264	329	0

Zylinder Serie 63 - Kolbenstange mit Faltenblag

Neue Version

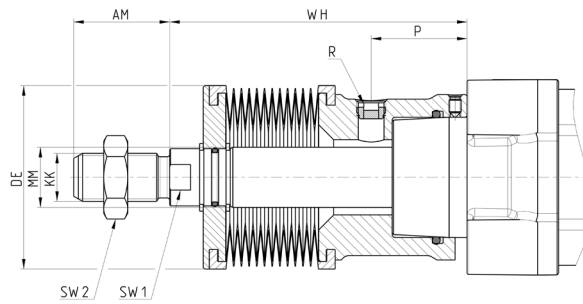

PRODUKTÜBERSICHT										
Ø	Hub	WH	AM	KK	MM	P	R	DE	SW1	SW2
32	0 ÷ 245	88	22	M10X1.25	12	25	G1/8	61	10	17
32	246 ÷ 490	132	22	M10X1.25	12	25	G1/8	61	10	17
40	0 ÷ 245	89	24	M12X1.25	16	26	G1/8	61	13	19
40	246 ÷ 490	133	24	M12X1.25	16	26	G1/8	61	13	19
50	0 ÷ 245	99	32	M16X1.5	20	30	G1/8	61	17	24
50	246 ÷ 490	143	32	M16X1.5	20	30	G1/8	61	17	24
63	0 ÷ 245	76	32	M16X1.5	20	16.5	G1/8	61	17	24
63	246 ÷ 490	120	32	M16X1.5	20	16.5	G1/8	61	17	24
80	0 ÷ 285	86	40	M20X1.5	25	11.5	G1/8	83	22	30
80	286 ÷ 570	139	40	M20X1.5	25	11.5	G1/8	83	22	30
100	0 ÷ 285	86	40	M20X1.5	25	12	G1/8	83	22	30
100	286 ÷ 570	139	40	M20X1.5	25	12	G1/8	83	22	30
125	0 ÷ 285	108	54	M27X2	32	30	G1/8	83	29	41
125	286 ÷ 570	161	54	M27X2	32	30	G1/8	83	29	41

Zylinder Serie 63 - Rundrohr, Boden/Boden-Montage

Neue Version

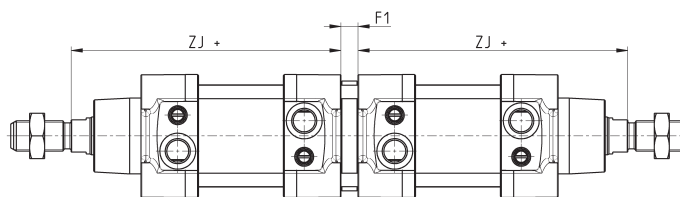

PRODUKTÜBERSICHT			
Ø	F1	ZJ+	
32	9	120	500
40	9	135	800
50	9	143	800
63	9	158	700
80	9	174	1000
100	9	189	900
125	20	225	1000

Mehrstellungsbausatz Mod. DC-63

Werkstoff: Aluminium

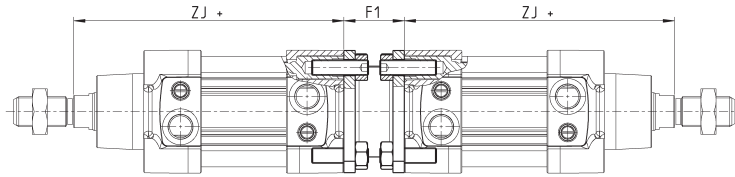
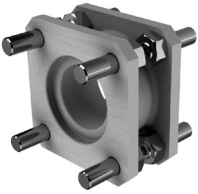

Lieferumfang:
1 Flansch
8 Madenschrauben
8 Muttern

ZYLINDER ISO 15552 SERIE 63

PRODUKTÜBERSICHT						
Mod.	∅	F1	ZJ+	Gewicht (g)	Gesamthub max. (mm)	Anzugsdrehmoment
DC-63-32	32	27	120	130	500	5 Nm
DC-63-40	40	27	135	160	800	5 Nm
DC-63-50	50	32	143	285	800	10 Nm
DC-63-63	63	28	158	340	700	10 Nm
DC-63-80	80	38	174	670	1000	15 Nm
DC-63-100	100	38	189	820	900	15 Nm
DC-63-125	125	48	225	1300	1000	20 Nm

Fußbefestigung Mod. B-41

Werkstoff: Stahl verzinkt

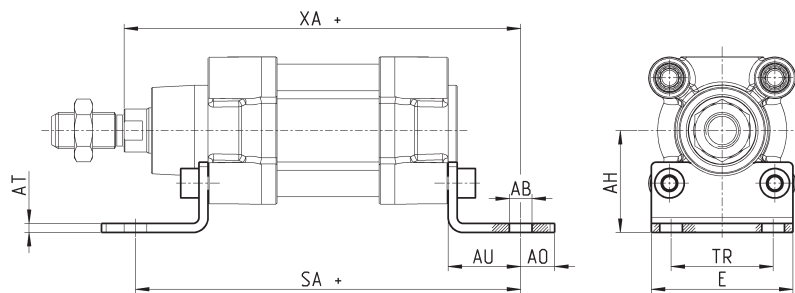

Lieferumfang:
2 Fußbefestigungen
4 Schrauben

+ Hub

PRODUKTÜBERSICHT											
Mod.	∅	AT	SA+	XA+	TR	E	AB	AH	AO	AU	Anzugsdrehmoment
B-41-32	32	4	142	144	32	45	7	32	11	24	5 Nm
B-41-40	40	4	161	163	36	53,5	10	36	15	28	5 Nm
B-41-50	50	4	170	175	45	62,5	10	45	15	32	10 Nm
B-41-63	63	5	185	190	50	73	10	50	15	32	10 Nm
B-41-80	80	6	210	216	63	92	12	63	20	41	15 Nm
B-41-100	100	6	220	230	75	108,5	14,5	71	25	41	15 Nm
B-41-125	125	7	250	270	90	132	16,5	90	25	45	20 Nm

Flansch vorn oder hinten Mod. D-E

Werkstoff: Aluminium



Lieferumfang:
1 Flansch
4 Schrauben
+ Hub

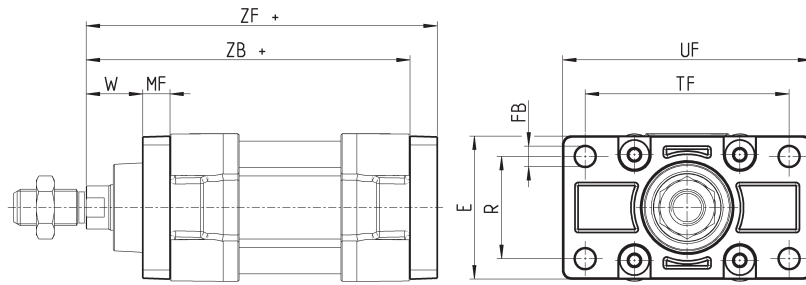

PRODUKTÜBERSICHT												
Mod.	Ø	W	MF	ZB	TF	R	UF	E	FB	ZF	Anzugsdrehmoment	
D-E-41-32	32	16	10	120	64	32	80	45	7	130	5 Nm	
D-E-41-40	40	20	10	135	72	36	90	52	9	145	5 Nm	
D-E-41-50	50	25	12	143	90	45	110	65	9	155	10 Nm	
D-E-41-63	63	25	12	158	100	50	120	75	9	170	10 Nm	
D-E-41-80	80	30	16	174	126	63	148	95	12	190	15 Nm	
D-E-41-100	100	35	16	189	150	75	176	115	14	205	15 Nm	
D-E-41-125	125	45	20	225	180	90	220	140	16	245	20 Nm	

Schwenkgabel hinten Mod. C und C-H

Werkstoff: Aluminium



Lieferumfang:
1 Schwenkgabel
4 Schrauben
+ Hub

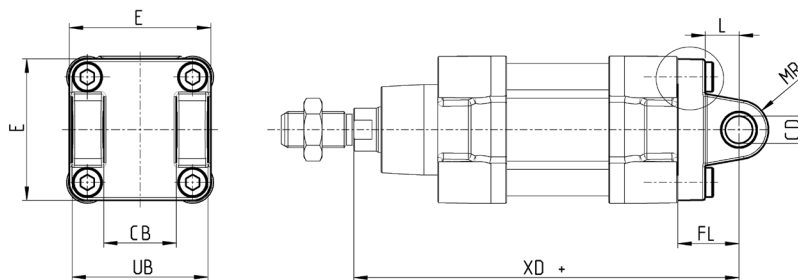

Ø 32



PRODUKTÜBERSICHT											
Mod.	Ø	CD	L	FL	XD	MR	E	CB	UB	Anzugsdrehmoment	
C-41-32	32	10	12.5	22	142	10	47	26	46.5	5 Nm	
C-41-40	40	12	16	25	160	12	52	28	52	5 Nm	
C-41-50	50	12	16	27	170	12	64	32	60	10 Nm	
C-H-41-63	63	16	21	32	190	16	74	40	70	10 Nm	
C-H-41-80	80	16	22	36	210	16	93	50	90	15 Nm	
C-H-41-100	100	20	27	41	230	20	114	60	110	15 Nm	
C-H-41-125	125	25	30	50	275	25	140	70	130	20 Nm	

Schwenkgabel vorne Mod. H und C-H

Werkstoff: Aluminium

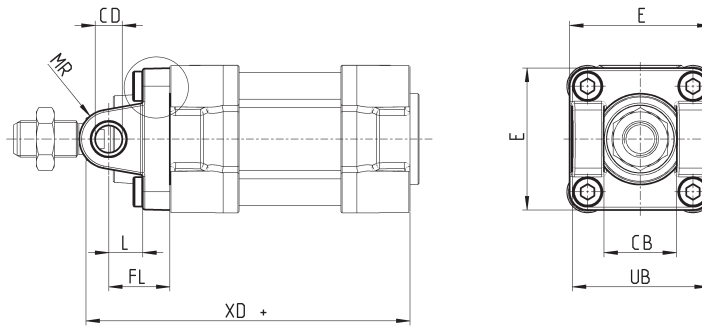

Lieferumfang:
1 Schwenkgabel
4 Schrauben

+ Hub

Ø 32



ZYLINDER ISO 15552 SERIE 63

PRODUKTÜBERSICHT

Mod.	Ø	CB	UB	E	XD+	FL	L	CD	MR	Anzugsdrehmoment
H-41-32	32	26	46.5	47	120	22	12.5	10	10	5 Nm
H-41-40	40	28	52	52	135	25	16	12	12	5 Nm
H-41-50	50	32	60	64	143	27	16	12	12	10 Nm
H-60-63	63	40	70	74	158	32	21	16	16	10 Nm
C-H-41-80	80	50	90	94	174	36	22	16	16	15 Nm
C-H-41-100	100	60	110	114	189	41	27	20	20	15 Nm
C-H-41-125	125	70	130	140	225	50	30	25	25	20 Nm

Schwenklager hinten Mod. L

Werkstoff: Aluminium

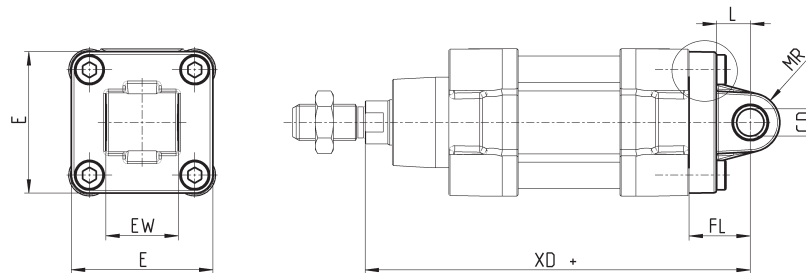

Lieferumfang:
1 Schwenklager
4 Schrauben

+ Hub

Ø 32



PRODUKTÜBERSICHT

Mod.	Ø	CD	L	FL	XD	MR	E	EW	Anzugsdrehmoment
L-41-32	32	10	12.5	22	142	10	47	26	5 Nm
L-41-40	40	12	16	25	160	12	52	28	5 Nm
L-41-50	50	12	16	27	170	12	64	32	10 Nm
L-41-63	63	16	21	32	190	15.5	74	40	10 Nm
L-41-80	80	16	22	36	210	16	94	50	15 Nm
L-41-100	100	20	27	41	230	20	114	60	15 Nm
L-41-125	125	25	30	50	275	25	140	70	20 Nm

Mittelschwenklager vorne Mod. FN

Werkstoff: Stahl verzinkt

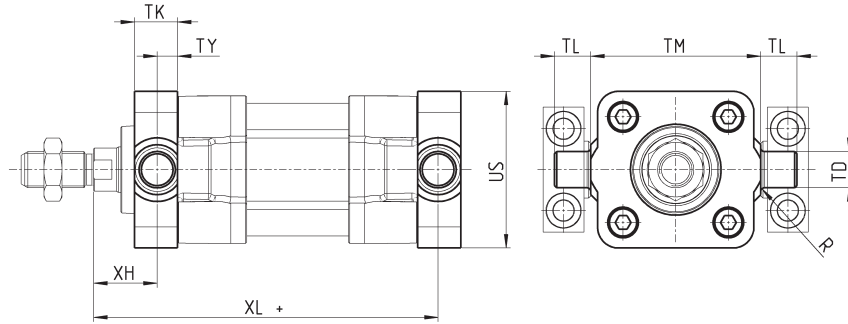
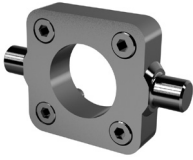

Lieferumfang:
1 Mittelschwenklager
4 Schrauben

+ Hub

PRODUKTÜBERSICHT											
Mod.	∅	TK	TY	XH	XL+	US	TL	TM	TD	R	Anzugsdrehmoment
FN-32	32	14	6.5	19.5	126.5	46	12	50	12	1	5 Nm
FN-40	40	19	9	21	144	59	16	63	16	1.5	5 Nm
FN-50	50	19	9	28	152	69	16	75	16	1.6	10 Nm
FN-63	63	24	11.5	25.5	169.5	84	20	90	20	1.6	10 Nm
FN-80	80	24	11.5	34.5	185.5	102	20	110	20	1.6	15 Nm
FN-100	100	29	14	37	203	125	25	132	25	2	15 Nm
FN-125	125	30	15	50	240	150	25	160	25	2	20 Nm

Schwenklager sphärisch Mod. R

Werkstoff: Aluminium
* nicht genormt

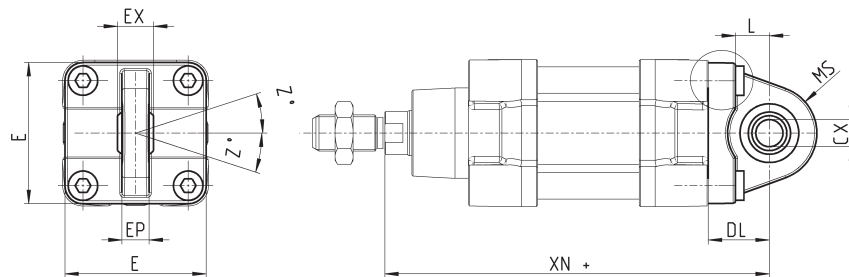

Lieferumfang:
1 Schwenklager
4 Schrauben

+ Hub

R-41-50/80/125

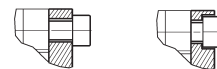

PRODUKTÜBERSICHT											
Mod.	∅	∅CX	L	DL+	XN+	MS	E	EX	EP	Z	Anzugsdrehmoment
R-41-32	32	10	13	22	142	16	45	14	10.5	4	5 Nm
R-41-40	40	12	16	25	160	19	52	16	12	4	5 Nm
R-41-50*	50	12	15	27	170	21	62.5	16	12	4	10 Nm
R-50	50	16	16	27	170	21,5	65	21	15	4	10 Nm
R-41-63	63	16	21	32	190	24	75	21	15	4	10 Nm
R-41-80*	80	16	24	36	210	28	92	21	15	4	15 Nm
R-80	80	20	22	36	210	28,5	95	25	18	4	15 Nm
R-41-100	100	20	27	41	230	30	115	25	18	4	15 Nm
R-41-125	125	30	30	50	275	40	140	37	25	4	20 Nm

Mittelschwenklager Mod. F (Rundrohr)



Werkstoff: Stahl verzinkt

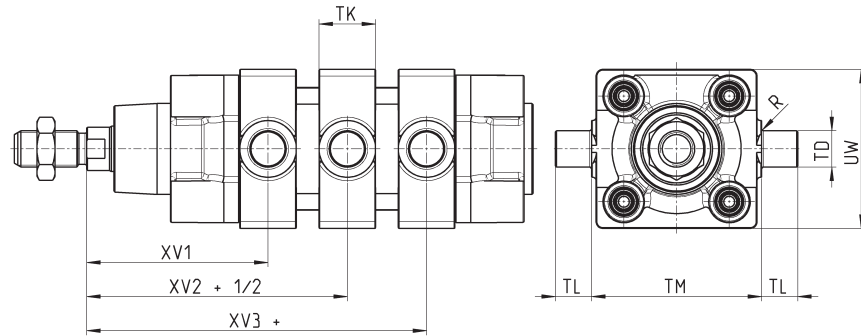

Lieferumfang:
1 Mittelschwenklager
8 Madenschrauben

+ Hub

ZYLINDER ISO 15552 SERIE 63

PRODUKTÜBERSICHT

Mod.	∅	XV1	XV2+	XV3+	TM	TK	TD	TL	UW	R
F-32	32	63	73	83	50	20	12	12	62	0.5
F-40	40	70	82.5	95	61	20	16	16	70	1
F-50	50	80	90	100	71	25	16	16	91	1
F-63	63	87	97.5	108	84	25	20	20	90	1
F-80	80	98	110	122	106	30	20	20	115	1
F-100	100	105.5	120	134.5	128	30	25	25	135	1.5
F-125	125	124	145	166	156	30	25	25	162	1.5

Mittelschwenklager Mod. F-63 (Profilrohr)



Werkstoff: Stahl verzinkt

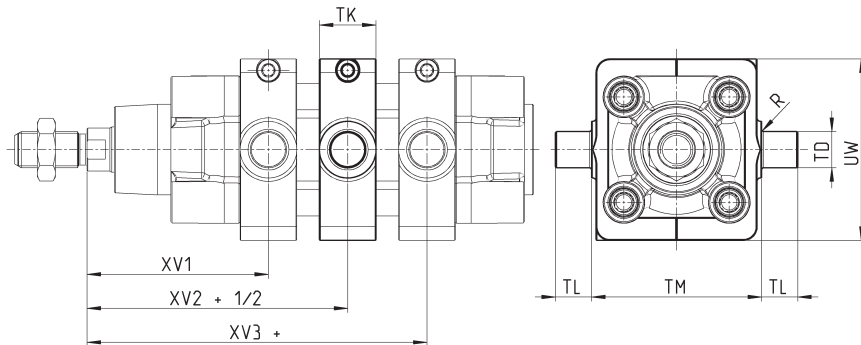

Lieferumfang:
1 Mittelschwenklager
8 Madenschrauben
2 Befestigungselemente

+ Hub

PRODUKTÜBERSICHT

Mod.	∅	XV1	XV2+	XV3+	TM	TK	TD	TL	UW	R
F-63-32	32	63	73	83	50	20	12	12	62	0.5
F-63-40	40	70	82.5	95	61	20	16	16	70	1
F-63-50	50	80	90	100	71	25	16	16	91	1
F-63-63	63	87	97.5	108	84	25	20	20	90	1
F-63-80	80	98	110	122	106	30	20	20	115	1
F-63-100	100	105.5	120	134.5	128	30	25	25	135	1.5
F-63-125	125	124	145	166	156	30	25	25	162	1.5

Montagebeispiel Kombination Mod. C, L, S

Werkstoff: Aluminium; Bestellbeispiel Ø 32): 1 Schwenkgabel (C-41-32), 1 Schwenklager (L-41-32), 1 Lagerbolzen (S-32) (müssen jeweils einzeln bestellt werden)



+ Hub

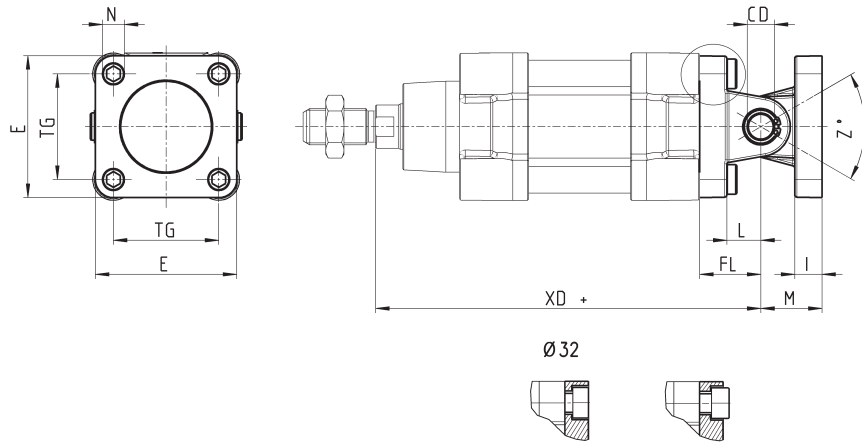

ABMESSUNGEN												
Mod.	Ø	E	TG	$\varnothing N$	XD+	$\varnothing CD$	L	FL	I	M	Z° (max)	Anzugsdrehmoment
C+L+S	32	47	32.5	6.5	142	10	12.5	22	9.5	22	30	5 Nm
C+L+S	40	52	38	6.5	160	12	16	25	9	25	40	5 Nm
C+L+S	50	64	46.5	9	170	12	16	27	11	27	25	10 Nm
C+L+S	63	74	56.5	9	190	16	21	32	11	32	36	10 Nm
C+L+S	80	94	72	11	210	16	22	36	14	36	34	15 Nm
C+L+S	100	114	89	11	230	20	27	41	14	41	38	15 Nm
C+L+S	125	140	110	13	275	25	30	50	20	50	30	20 Nm

Lagerbock 90° mit starrem Lager Mod. ZC

CETOP RP 107P
Werkstoff: Aluminium

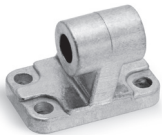

Lieferumfang:
1 Lagerbock

+ Hub

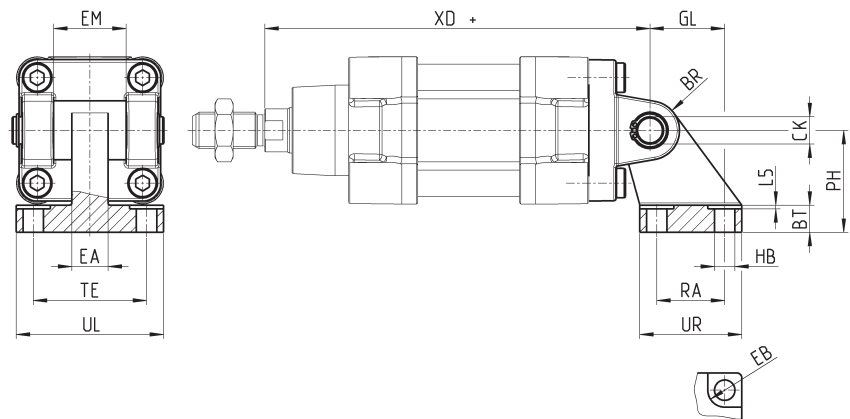

PRODUKTÜBERSICHT																
Mod.	Ø	EB	CK	HB	XD+	TE	UL	EA	GL	L5	RA	EM	UR	PH	BT	BR
ZC-32	32	11	10	6,6	142	38	51	10	21	1,6	18	26	31	32	8	10
ZC-40	40	11	12	6,6	160	41	54	15	24	1,6	22	28	35	36	10	11
ZC-50	50	15	12	9	170	50	65	16	33	1,6	30	32	45	45	12	13
ZC-63	63	15	16	9	190	52	67	16	37	1,6	35	40	50	50	14	15
ZC-80	80	18	16	11	210	66	86	20	47	2,5	40	50	60	63	14	15
ZC-100	100	18	20	11	230	76	96	20	55	2,5	50	60	70	71	17	19
ZC-125	125	20	25	14	275	94	124	30	70	3,2	60	70	90	90	20	22,5

Lagerbock für Mittelschwenklager Mod. BF

Werkstoff: Aluminium

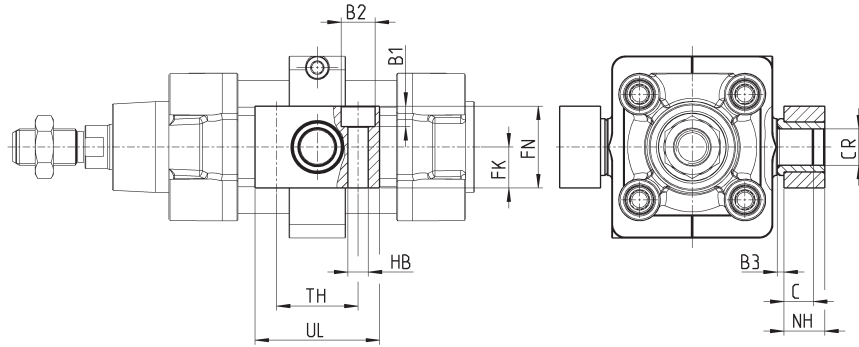

Lieferumfang:
2 Lagerböcke

ZYLINDER ISO 15552 SERIE 63

PRODUKTÜBERSICHT

Mod.	∅	ϕ_{CR}	NH	C	B3	TH	UL	FK	FN	B1	B2	HB
BF-32	32	12	15	7,5	3	32	46	15	30	6,8	11	6,6
BF-40-50	40 - 50	16	18	9	3	36	55	18	36	9	15	9
BF-63-80	63 - 80	20	20	10	3	42	65	20	40	11	18	11
BF-100-125	100 - 125	25	25	12,5	3,5	50	75	25	50	13	20	14

Befestigungskit Mod. PCV

Das Befestigungskit Mod. PCV ermöglicht die Montage eines Ventils/Elektromagnetventils direkt am Zylinder. Es entsteht eine Zylinderventileinheit.

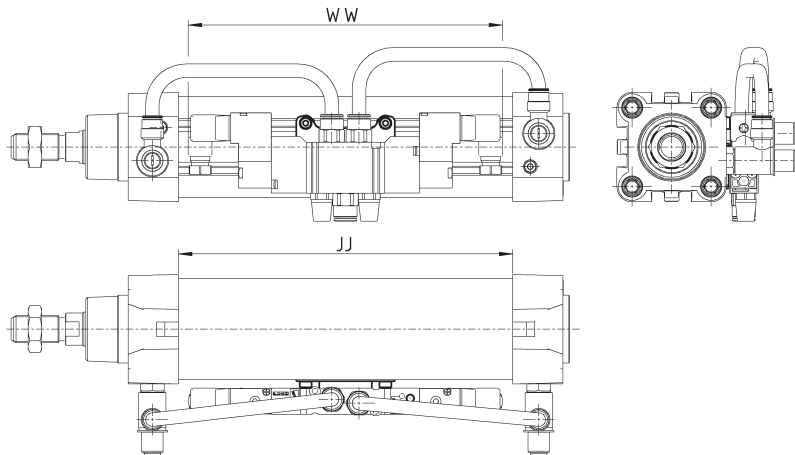

Die Gesamtlänge des gewählten Ventils (ww) sollte immer kleiner sein, als die Abmessung JJ des gewählten Zylinders. Weitere Informationen unter <http://catalogue.camozzi.com/downloads>.

PRODUKTÜBERSICHT

Mod.	
PCV-62-K3	zur Befestigung von Ventilen Serie 3
PCV-62-K4	zur Befestigung von Ventilen Serie 4 Anschluss G1/4"
PCV-62-KEN	zur Befestigung von Ventilen Serie EN
PCV-62-K8	zur Befestigung von Ventilen Serie 4 Anchl. G1/8" + Serie 3 Anchl. G1/4"

Lagerbolzen Mod. S



Lieferumfang:
1 Lagerbolzen (Edelstahl 1.4305)
2 Seegerringe (Stahl)

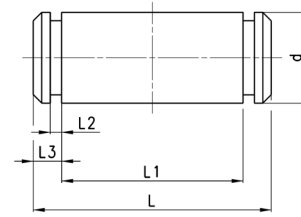

PRODUKTÜBERSICHT						
Mod.	∅	d	L	L1	L2	L3
S-32	32	10	52	46	1.1	3
S-40	40	12	59	53	1.1	3
S-50	50	12	67	61	1.1	3
S-63	63	16	77	71	1.1	3
S-80	80	16	97	91	1.1	3
S-100	100	20	121	111	1.3	5
S-125	125	25	140.5	132	1.3	4.25

Gelenkauge Mod. GA



ISO 8139
Werkstoff: Stahl verzinkt

Lieferumfang:
1 Gelenkauge

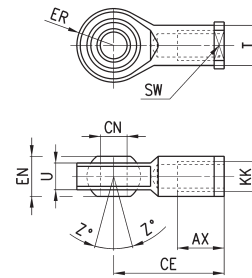

PRODUKTÜBERSICHT										
Mod.	∅CN ^(H7)	U	EN	ER	AX	CE	KK	∅T	Z	SW
GA-32	10	10,5	14	14	20	43	M10X1,25	15	6,5	17
GA-40	12	12	16	16	22	50	M12X1,25	17,5	6,5	19
GA-50-63	16	15	21	21	28	64	M16X1,5	22	7,5	22
GA-80-100	20	18	25	25	33	77	M20x1,5	27,5	7	30
GA-41-125	30	25	37	37	51	110	M27x2	40	7,5	41

Ausgleichskupplung Mod. GY

Werkstoff: Zinkdruckguss und Stahl verzinkt



Lieferumfang:
1 Ausgleichskupplung

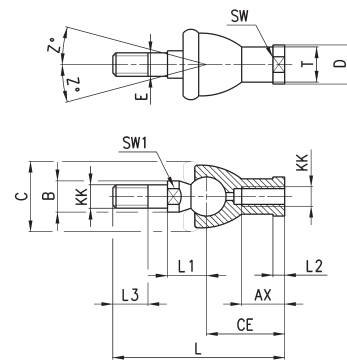

PRODUKTÜBERSICHT																
Mod.	∅	KK	L	CE	L2	AX	SW	SW1	L1	L3	∅T	∅D	E	∅B	∅C	Z
GY-32	32	M10X1,25	74	35	6,5	18	17	11	19,5	15	15	19	10	14	28	15
GY-40	40	M12X1,25	84	40	6,5	20	19	17	21	17	17,5	22	12	19	32	15
GY-50-63	50-63	M16X1,5	112	50	8	27	22	19	27,5	23	22	27	16	22	40	11
GY-80-100	80-100	M20x1,5	133	63	10	38	30	24	31,5	25	27,5	34	20	27	45	7,5

Gabelkopf Mod. G

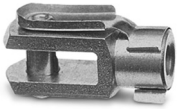

Werkstoff: Stahl verzinkt

Lieferumfang:
1 Gabelkopf

PRODUKTÜBERSICHT									
Mod.	ø _{CK}	LE	CM	CL	ER	CE	KK	B	ø _{B1}
G-25-32	10	20	10	20	12	40	M10 X 1,25	26	18
G-40	12	24	12	24	14	48	M12 X 1,25	32	20
G-50-63	16	32	16	32	19	64	M16 X 1,5	40	26
G-80-100	20	40	20	40	25	80	M20 X 1,5	48	34
G-41-125	30	54	30	55	38	110	M27 X 2	74	48

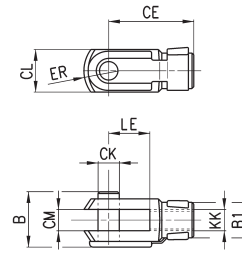

Kolbenstangenmutter Mod. U



UNI EN ISO 4035
Werkstoff: Stahl verzinkt

Lieferumfang:
1 Kolbenstangenmutter

PRODUKTÜBERSICHT			
Mod.	D	m	SW
U-25-32	M10X1,25	6	17
U-40	M12X1,25	7	19
U-50-63	M16X1,5	8	24
U-80-100	M20x1,5	9	30
U-41-125	M27x2	12	41

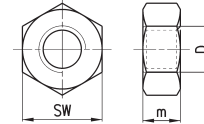

Ausgleichskupplung Mod. GK



Werkstoff: Stahl verzinkt

Lieferumfang:
1 Ausgleichskupplung

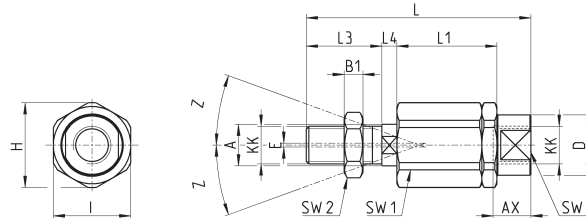

PRODUKTÜBERSICHT																	
Mod.	Ø	KK	L	L1	L3	L4	ø _A	ø _D	H	I	SW	SW1	SW2	B1	AX	Z	E
GK-25-32	25-32	M10x1,25	71,5	35	20	7,5	14	22	32	30	19	12	17	5	22	4	2
GK-40	40	M12x1,25	75,5	35	24	7,5	14	22	32	30	19	12	19	6	22	4	2
GK-50-63	50-63	M16x1,5	104	53	32	10	22	32	45	41	27	20	24	8	30	3	2
GK-80-100	80-100	M20x1,5	119	53	40	10	22	32	45	41	27	20	30	10	37	3	2
GK-125	125	M27x2	147	60	54	10	32	57	70	65	54	24	41	12	48	4	2

Ausgleichsflansch Mod. GKF

Werkstoff: Stahl verzinkt

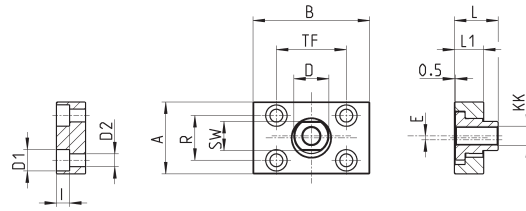

Lieferumfang:
1 Ausgleichsflansch

PRODUKTÜBERSICHT

Mod.	Ø	KK	A	B	R	TF	L	L1	I	Ø D	Ø D1	Ø D2	SW	E
GKF-25-32	32	M10x1,25	37	60	23	36	22,5	15	6,8	18	11	6,6	15	2
GKF-40	40	M12x1,25	56	60	38	42	22,5	15	9	20	15	9	15	2,5
GKF-50-63	50-63	M16x1,5	80	80	58	58	26,5	15	10,5	25	18	11	22	2,5
GKF-80-100	80-100	M20x1,5	90	90	65	65	32,5	20	13	30,5	20	14	27	2,5
GKF-125	125	M27x2	90	90	65	65	35,5	20	13	40	20	14	36	4

Demontagewerkzeug für Zylinder Ø 80 und 100 mm (Rundrohr)

Werkstoff: Stahl gehärtet

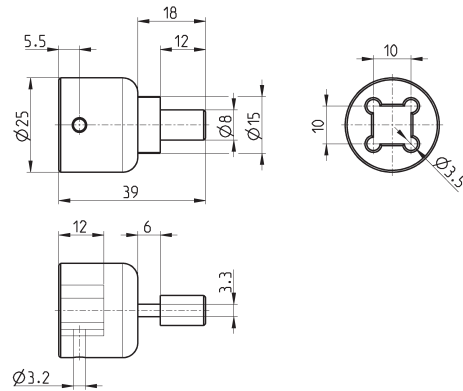
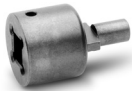

Mod.
80-62/8C