

Series CGZT three-jaw grippers with T-guide

Single and double acting, magnetic, self-centering
Sizes: 40, 50, 64, 80, 100, 125, 160 mm



The new Series CGZT pneumatic grippers, thanks to the use of a high performing and precise force transmission system, are able to provide high gripping forces, while guaranteeing high repeatability in a compact and light design.

Available in 7 sizes (40, 50, 64, 80, 100, 125 and 160) and three different versions (double acting, single acting NO and single acting NC), allows you to find the best solution for every handling need. They are also available with a part retaining unit. This gripper series results particularly suitable to be combined with anthropomorphic or collaborative robots and gantry systems for applications in Pick and Place units, Material handling and the loading/unloading operations of machine tools.

- » Robust and light
- » 3 self-centering jaws
- » IP40
- » Fixing from the top and from below
- » Supply on the side or on the bottom (even without using tubes)
- » Double position detection
- » Variants available: for use in ATEX zones and for high temperatures
- » In compliance with ROHS directive
- » High positioning repeatability
- » High resistance and reliability to external loads thanks to T-guide
- » Free from Copper, PTFE and Silicone

GENERAL DATA

Type of construction	Three-jaw self-centering gripper with T-guide
Operation	Single acting (NO, NC) double acting
Sizes	40, 50, 64, 80, 100, 125, 160 mm
Force transmission	Lever
Air connections	M3 (40), M5 (50, 64, 80), G1/8 (100, 125, 160)
Working pressure	2 ÷ 8 bar (double acting), 4 ÷ 8 bar (single acting)
Working temperature	5°C ÷ 60°C (standard) - 5°C ÷ 130°C (high temperature version)
Store temperature	-10°C ÷ 80°C
Maximum use frequency	5 Hz (40, 50, 64); 3 Hz (80); 2 Hz (100, 125); 1 Hz (160)
Repeatability	≤ 0.02 mm
Interchangeability	0.1 mm
Medium	Air in class 7.4.4 according to ISO 8573-1. In case lubricated air is used, we recommend ISOVG32 oil and to never interrupt lubrication.
Lubrication	After 10 million cycles, grease the sliding zones using Molykote DX grease.
Protection class	IP40
Compatibility	ROHS Directive
Certifications	ATEX (II2G Ex h IIC T4 Gb II2D Ex h IIIC T120° Db -20°C ≤ Ta ≤ 70°C). Add EX at the end of the commercial code to order the ATEX version.
Materials	Free from Copper, PTFE and Silicone

NOTE: Pressurize the pneumatic system gradually in order to avoid uncontrolled movements.

CODING EXAMPLE

CGZT	-	050	-	NC	-	W	EX
-------------	----------	------------	----------	-----------	----------	----------	-----------

CGZT	SERIES	
050	SIZES: 040 = Ø25 050 = Ø33 064 = Ø43 080 = Ø54 100 = Ø76 125 = Ø96 160 = Ø125	
NC	FUNCTIONING: = double acting NO = single acting, normally open NC = single acting, normally closed	PNEUMATIC SYMBOLS PNZ1 PNZ3 PNZ2
W	VERSION: = standard W = high temperatures (130°C) - non magnetic	
EX	Add EX to order the certified ATEX version	

PNEUMATIC SYMBOLS

The pneumatic symbols which have been indicated in the CODING EXAMPLE are shown below.

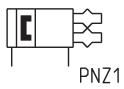

Series CGPT gripper - construction

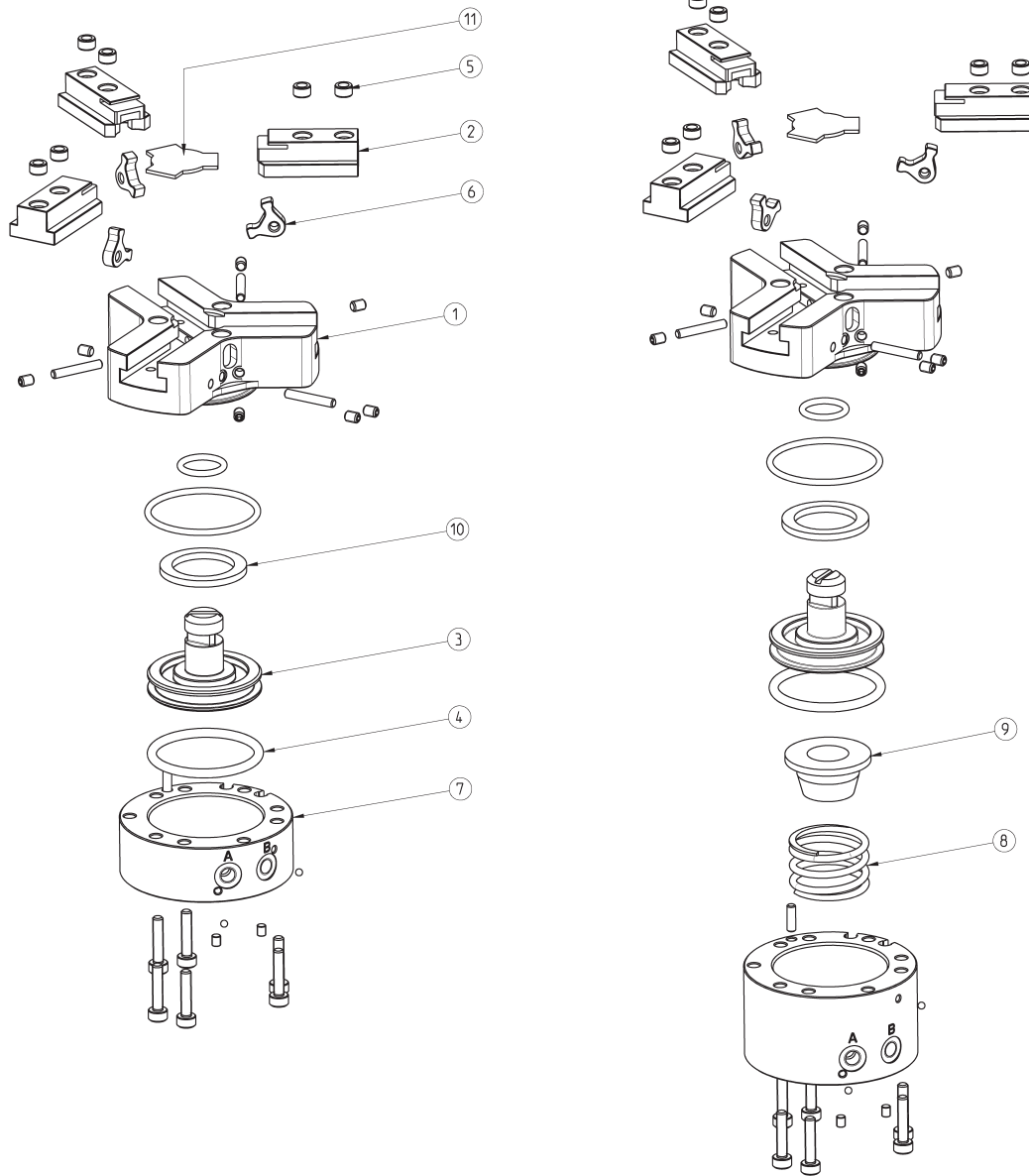

LIST OF COMPONENTS

PARTS	MATERIALS
1 - Body	Aluminium
2 - Jaw	Stainless steel
3 - Piston	Stainless steel
4 - Seals	HNBR / FKM
5 - Centering bushes	Stainless steel
6 - Levers	Steel
7 - End cover	Aluminium
8 - Spring	Steel
9 - Guide de ressort	Aluminium
10 - Magnet	Neodymium
11 - Cover	Stainless steel

CGZT gripper, size 40mm - dimensions



DRAWING LEGEND:
A = Opening of air connection
B = Closing of air connection
C = Closed gripper
D = Open gripper

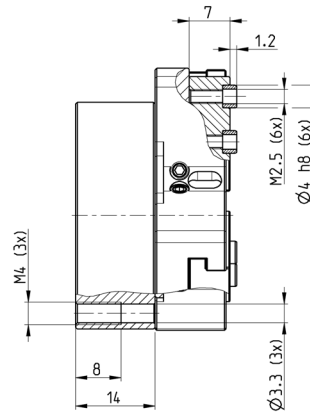
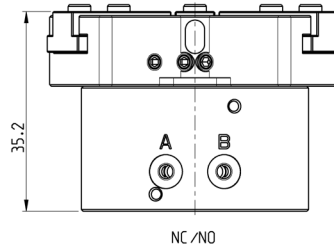
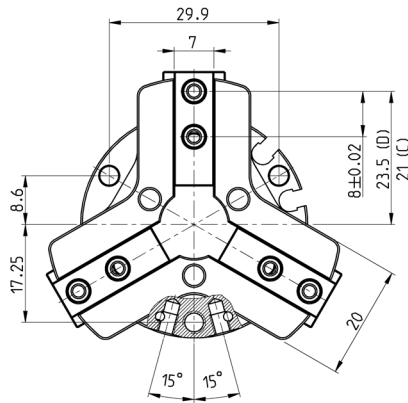
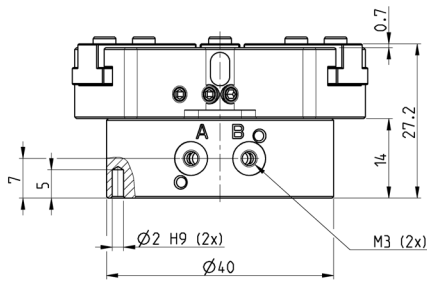
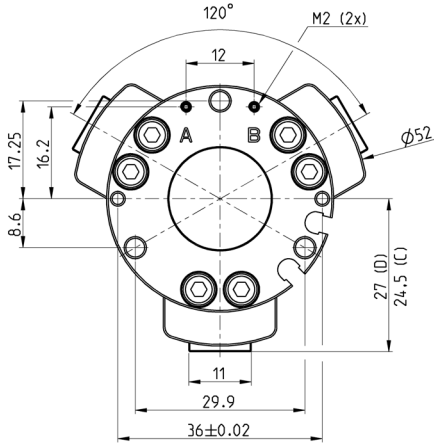

Mod.	Closing gripping force each jaw at 6 bar (N)	Total closing gripping force at 6 bar (N)	Opening gripping force each jaw at 6 bar (N)	Total opening gripping force at 6 bar (N)	Stroke per jaw (mm)	Working pressure (bar)	Working temperature (°C)	Repeatability (mm)	Opening T (ms)	Closing T (ms)	Weight (Kg)
CGZT-040	60	181	67	202	2.5	2 ÷ 8	5 ÷ 60	≤ 0.02	57	63	0.114
CGZT-040-NC	93	80	33	100	2.5	4 ÷ 8	5 ÷ 60	≤ 0.02	56	106	0.132
CGZT-040-NO	27	280	100	300	2.5	4 ÷ 8	5 ÷ 60	≤ 0.02	79	49	0.130

CGZT gripper, size 50mm - dimensions



DRAWING LEGEND:
 A = Opening of air connection
 B = Closing of air connection
 C = Closed gripper
 D = Open gripper

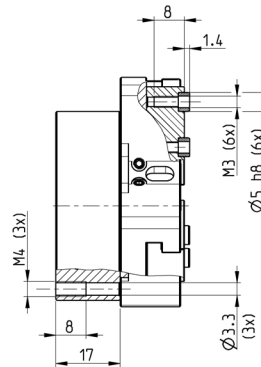
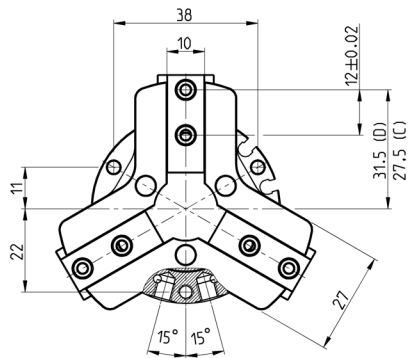
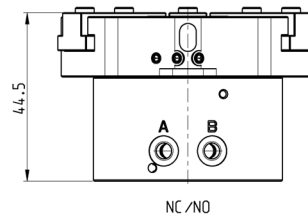
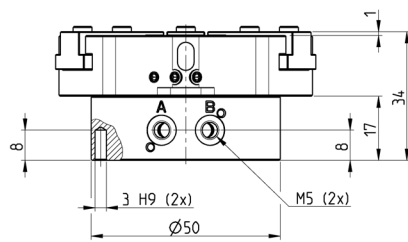
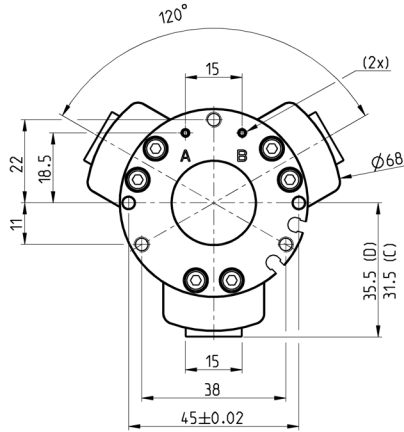

Mod.	Closing gripping force each jaw at 6 bar (N)	Total closing gripping force at 6 bar (N)	Opening gripping force each jaw at 6 bar (N)	Total opening gripping force at 6 bar (N)	Stroke per jaw (mm)	Working pressure (bar)	Working temperature (°C)	Repeatability (mm)	Opening T (ms)	Closing T (ms)	Weight (Kg)
CGZT-050	115	346	130	390	4	2 ÷ 8	5 ÷ 60	≤ 0.02	75	85	0.240
CGZT-050-NC	160	480	83	250	4	4 ÷ 8	5 ÷ 60	≤ 0.02	56	151	0.280
CGZT-050-NO	70	210	173	520	4	4 ÷ 8	5 ÷ 60	≤ 0.02	137	55	0.275

CGZT gripper, size 64mm - dimensions



SERIES CGZT THREE-JAW GRIPPERS WITH T-GUIDE

DRAWING LEGEND:
A = Opening of air connection
B = Closing of air connection
C = Closed gripper
D = Open gripper

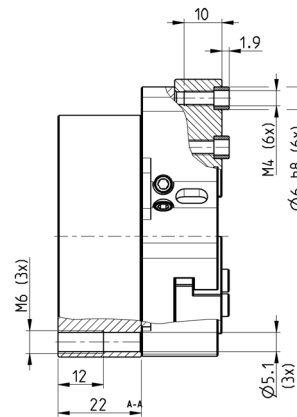
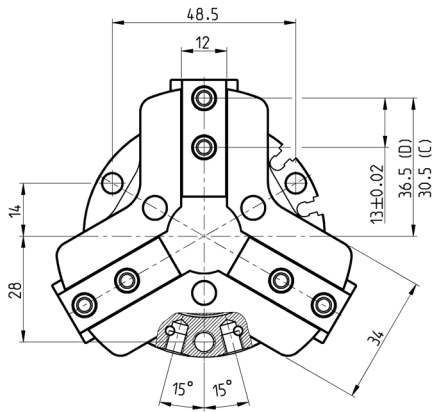
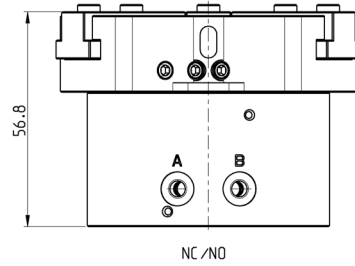
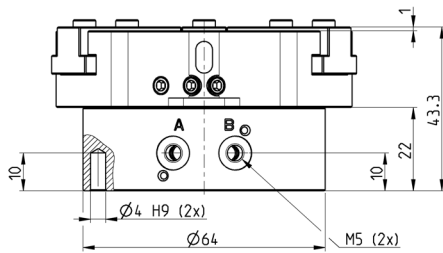
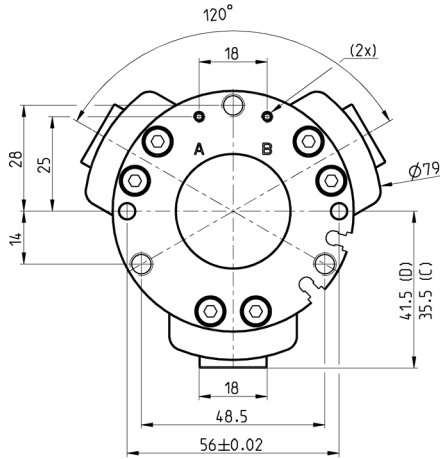

Mod.	Closing gripping force each jaw at 6 bar (N)	Total closing gripping force at 6 bar (N)	Opening gripping force each jaw at 6 bar (N)	Total opening gripping force at 6 bar (N)	Stroke per jaw (mm)	Working pressure (bar)	Working temperature (°C)	Repeatability (mm)	Opening T (ms)	Closing T (ms)	Weight (Kg)
CGZT-064	223	670	242	726	6	2 ÷ 8	5 ÷ 60	≤ 0.02	85	104	0.461
CGZT-064-NC	320	960	147	440	6	4 ÷ 8	5 ÷ 60	≤ 0.02	88	158	0.560
CGZT-064-NO	127	380	323	970	6	4 ÷ 8	5 ÷ 60	≤ 0.02	153	71	0.537

CGZT gripper, size 80mm - dimensions



DRAWING LEGEND:
 A = Opening of air connection
 B = Closing of air connection
 C = Closed gripper
 D = Open gripper

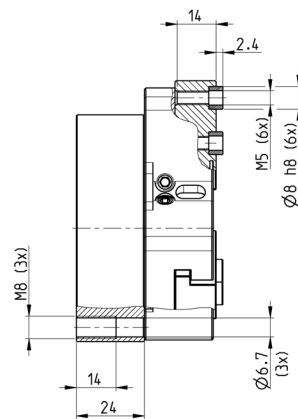
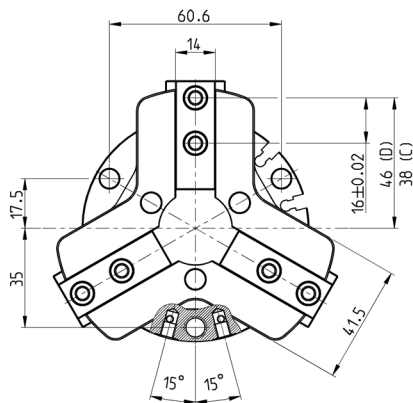
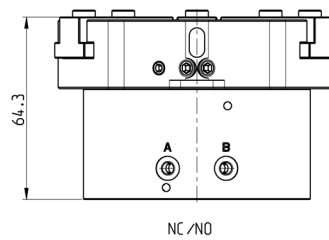
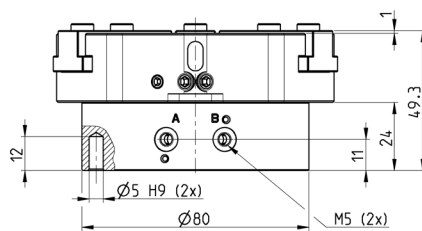
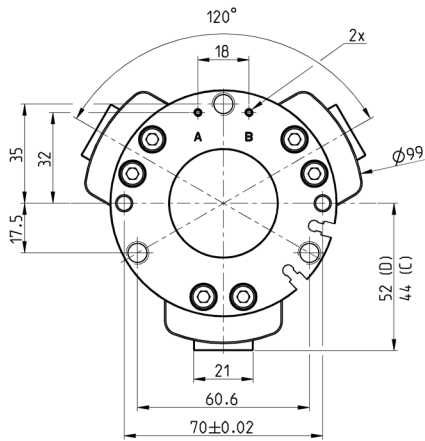

Mod.	Closing gripping force each jaw at 6 bar (N)	Total closing gripping force at 6 bar (N)	Opening gripping force each jaw at 6 bar (N)	Total opening gripping force at 6 bar (N)	Stroke per jaw (mm)	Working pressure (bar)	Working temperature (°C)	Repeatability (mm)	Opening T (ms)	Closing T (ms)	Weight (Kg)
CGZT-080	327	980	359	1078	8	2 ÷ 8	5 ÷ 60	≤ 0.02	116	133	0.796
CGZT-080-NC	437	1310	247	740	8	4 ÷ 8	5 ÷ 60	≤ 0.02	88	258	0.987
CGZT-080-NO	213	640	450	1350	8	4 ÷ 8	5 ÷ 60	≤ 0.02	195	73	0.934

CGZT gripper, size 100mm - dimensions



DRAWING LEGEND:
 A = Opening of air connection
 B = Closing of air connection
 C = Closed gripper
 D = Open gripper

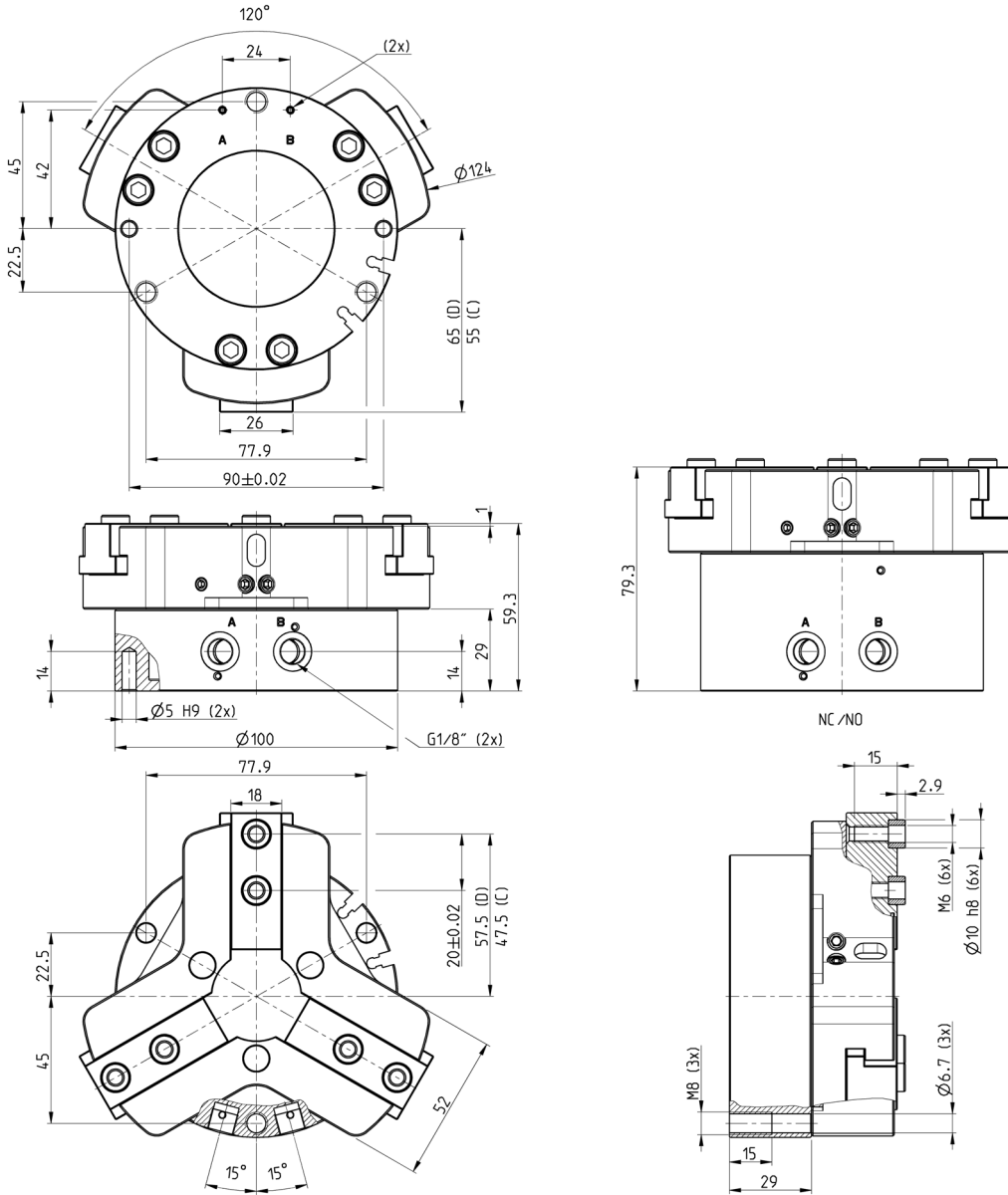

Mod.	Closing gripping force each jaw at 6 bar (N)	Total closing gripping force at 6 bar (N)	Opening gripping force each jaw at 6 bar (N)	Total opening gripping force at 6 bar (N)	Stroke per jaw (mm)	Working pressure (bar)	Working temperature (°C)	Repeatability (mm)	Opening T (ms)	Closing T (ms)	Weight (Kg)
CGZT-100	677	2030	722	2165	10	2 ÷ 8	5 ÷ 60	≤ 0.02	135	155	1.483
CGZT-100-NC	873	2620	523	1570	10	4 ÷ 8	5 ÷ 60	≤ 0.02	74	254	1.790
CGZT-100-NO	480	1440	917	2750	10	4 ÷ 8	5 ÷ 60	≤ 0.02	282	75	1.755

CGZT gripper, size 125mm - dimensions



DRAWING LEGEND:
 A = Opening of air connection
 B = Closing of air connection
 C = Closed gripper
 D = Open gripper

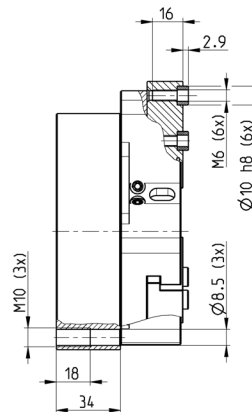
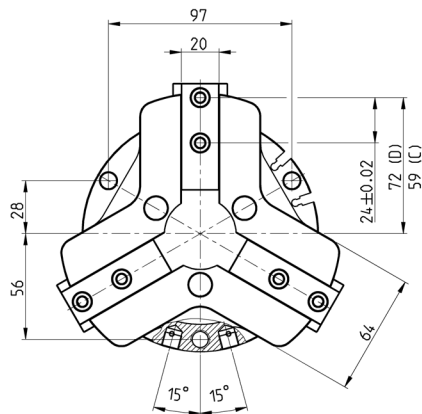
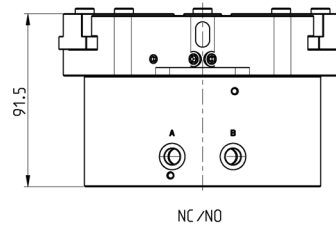
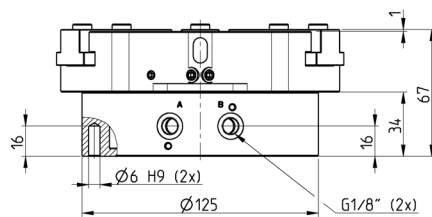
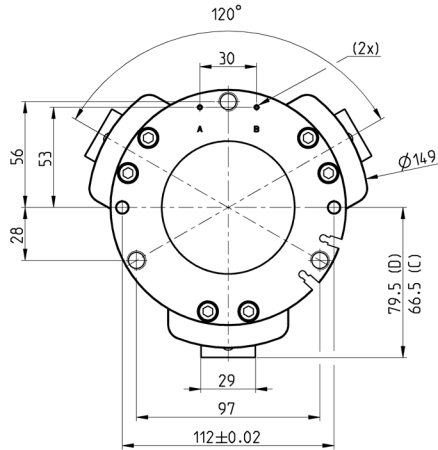

Mod.	Closing gripping force each jaw at 6 bar (N)	Total closing gripping force at 6 bar (N)	Opening gripping force each jaw at 6 bar (N)	Total opening gripping force at 6 bar (N)	Stroke per jaw (mm)	Working pressure (bar)	Working temperature (°C)	Repeatability (mm)	Opening T (ms)	Closing T (ms)	Weight (Kg)
CGZT-125	1123	3370	1198	3594	13	2 ÷ 8	5 ÷ 60	≤ 0.02	198	227	2.220
CGZT-125-NC	1400	4200	920	2760	13	4 ÷ 8	5 ÷ 60	≤ 0.02	108	349	3.005
CGZT-125-NO	843	2530	1477	4430	13	4 ÷ 8	5 ÷ 60	≤ 0.02	329	119	2.752

CGZT gripper, size 160mm - dimensions



SERIES CGZT THREE-JAW GRIPPERS WITH T-GUIDE

DRAWING LEGEND:
A = Opening of air connection
B = Closing of air connection
C = Closed gripper
D = Open gripper

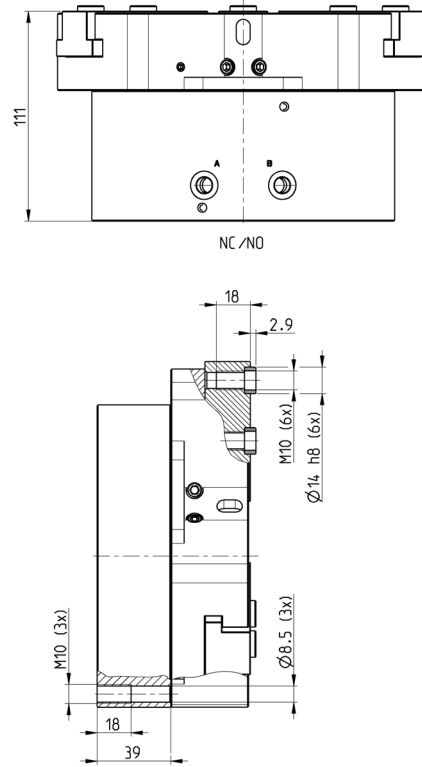
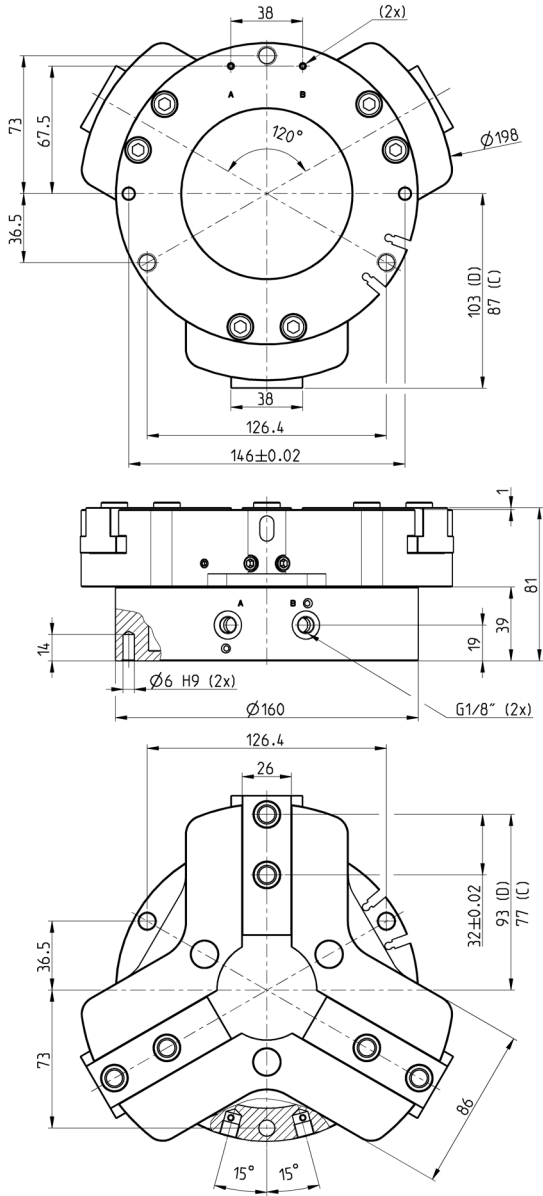

Mod.	Closing gripping force each jaw at 6 bar (N)	Total closing gripping force at 6 bar (N)	Opening gripping force each jaw at 6 bar (N)	Total opening gripping force at 6 bar (N)	Stroke per jaw (mm)	Working pressure (bar)	Working temperature (°C)	Repeatability (mm)	Opening T (ms)	Closing T (ms)	Weight (Kg)
CGZT-160	1927	5300	1767	5780	16	2 ÷ 8	5 ÷ 60	≤ 0.02	239	304	4.714
CGZT-160-NC	2150	6450	1540	4620	16	4 ÷ 8	5 ÷ 60	≤ 0.02	150	791	6.504
CGZT-160-NO	1380	4140	2310	6930	16	4 ÷ 8	5 ÷ 60	≤ 0.02	418	129	5.851

GRIPPING FORCE PER SINGLE JAW

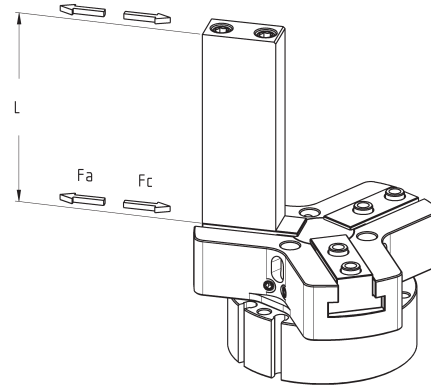
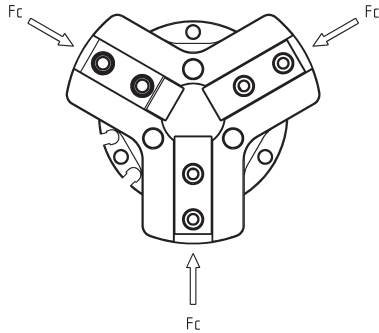

The total gripping force has to be calculated as follows:
 Total $F_c = F_c \times 3$
 Total $F_a = F_a \times 3$

F_c = closing gripping force
 F_a = opening gripping force
 L = gripping point length

SERIES CGZT THREE-JAW GRIPPERS WITH T-GUIDE

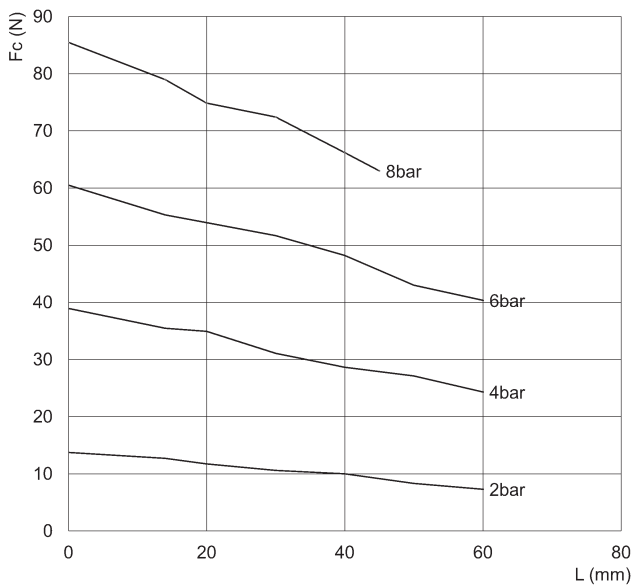

CGZT-040

F_c = closing gripping force
 L = gripping point length

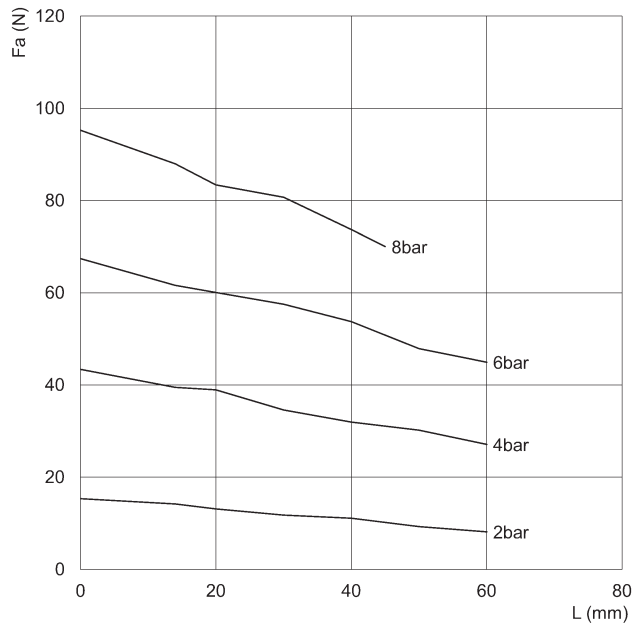

CGZT-040

F_a = opening gripping force
 L = gripping point length

GRIPPING FORCE PER SINGLE JAW

SERIES CGZT THREE-JAW GRIPPERS WITH T-GUIDE

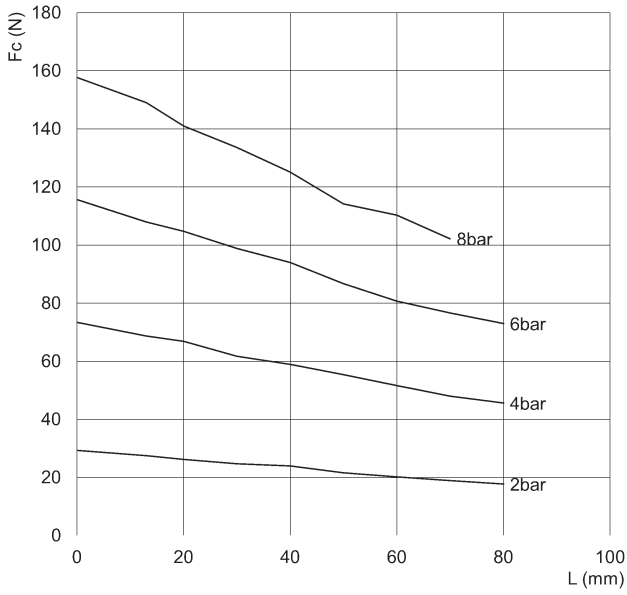

CGZT-050

Fc = closing gripping force
L = gripping point length

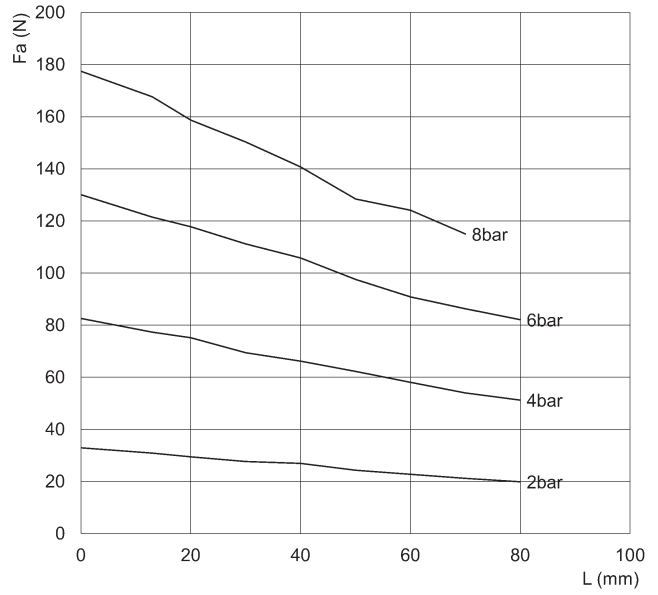

CGZT-050

Fa = opening gripping force
L = gripping point length

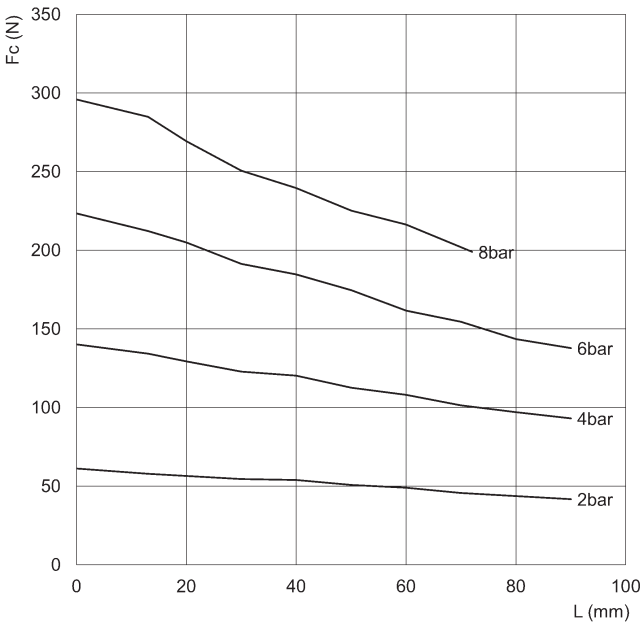

CGZT-064

Fc = closing gripping force
L = gripping point length

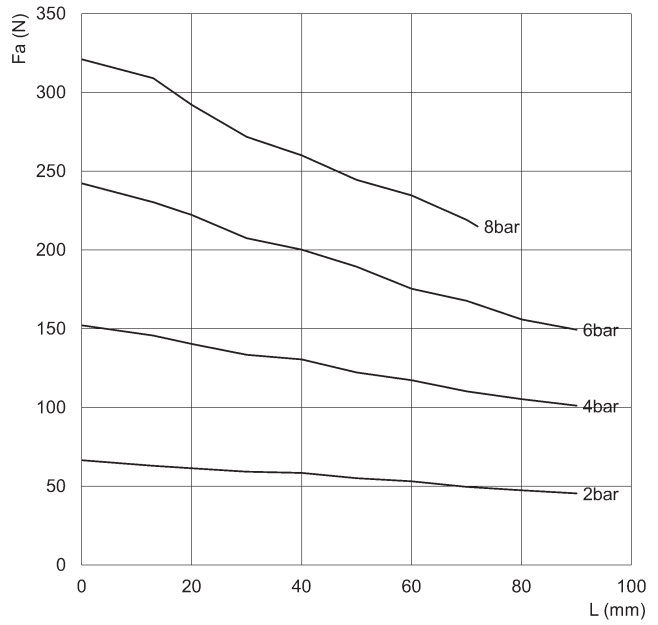

CGZT-064

Fa = opening gripping force
L = gripping point length

GRIPPING FORCE PER SINGLE JAW

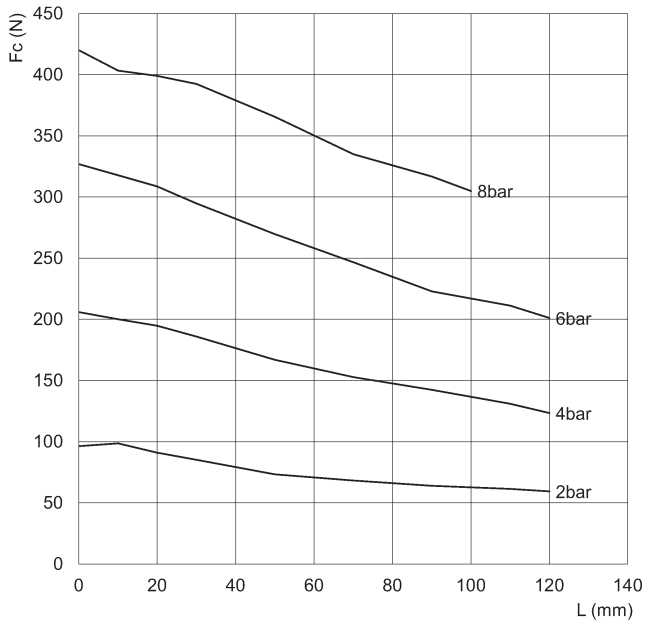

CGZT-080

Fc = closing gripping force
L = gripping point length

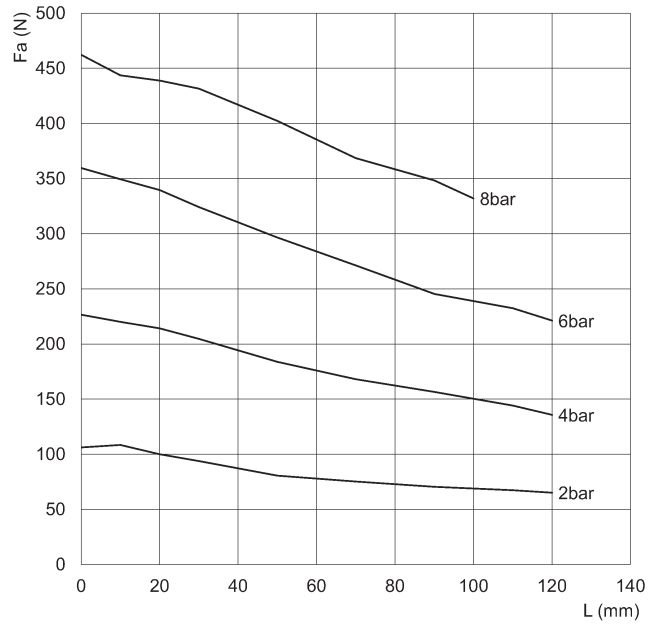

CGZT-080

Fa = opening gripping force
L = gripping point length

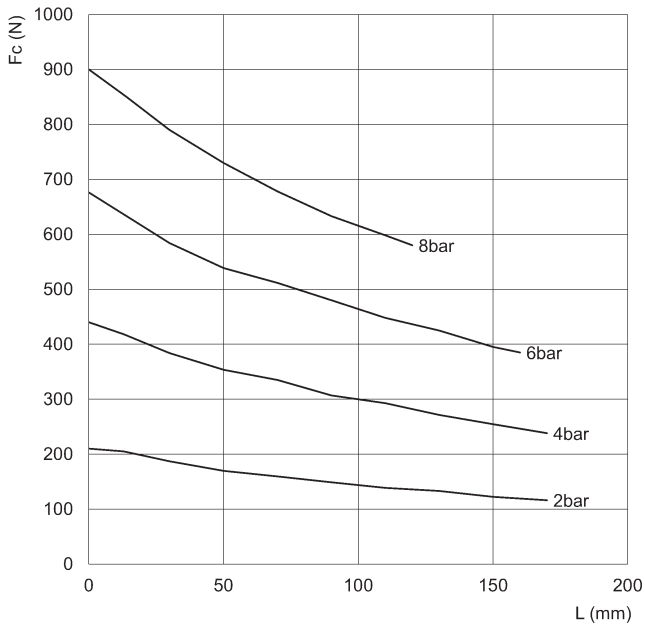

CGZT-100

Fc = closing gripping force
L = gripping point length

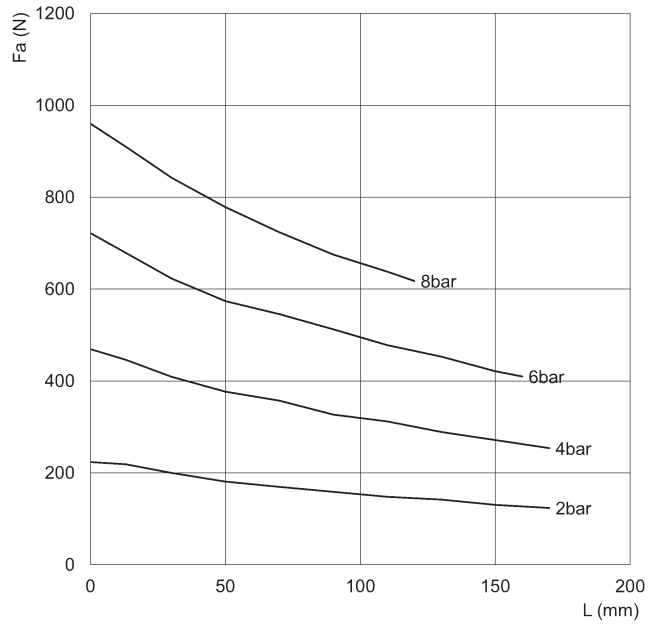

CGZT-100

Fa = opening gripping force
L = gripping point length

SERIES CGZT THREE-JAW GRIPPERS WITH T-GUIDE

GRIPPING FORCE PER SINGLE JAW

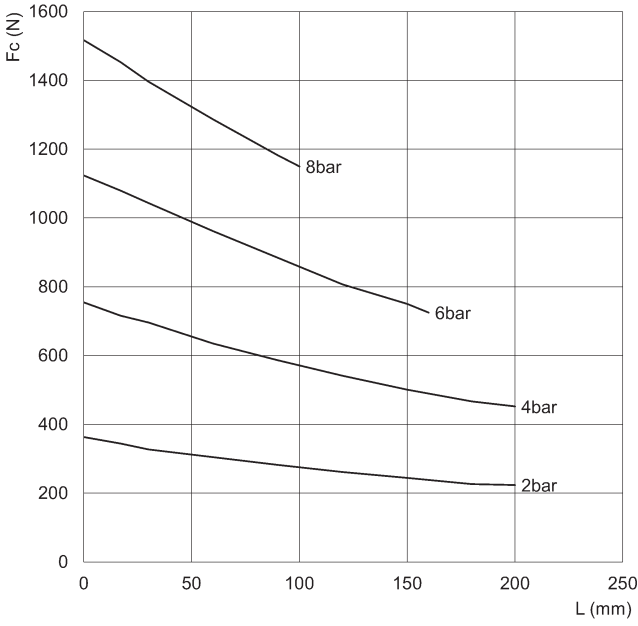

CGZT-125

Fc = closing gripping force
L = gripping point length

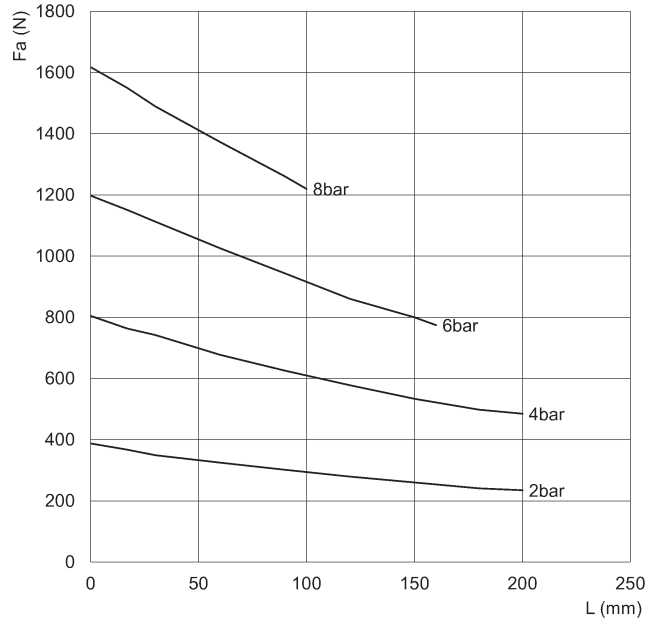

CGZT-125

Fa = opening gripping force
L = gripping point length

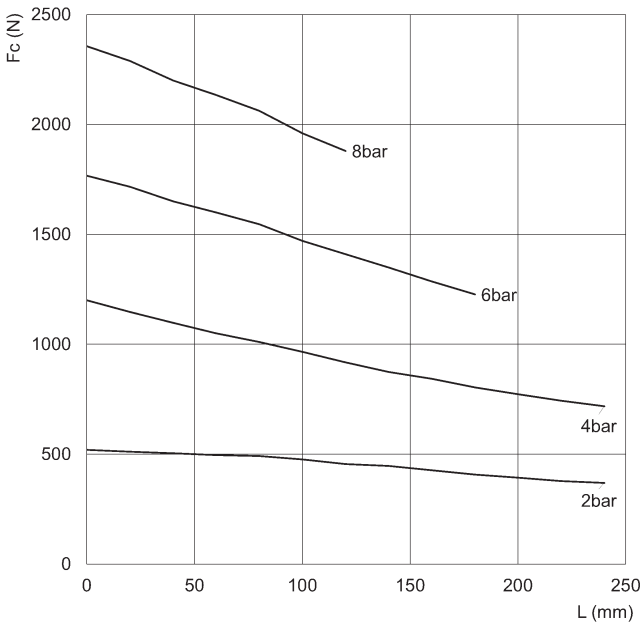

CGZT-160

Fc = closing gripping force
L = gripping point length

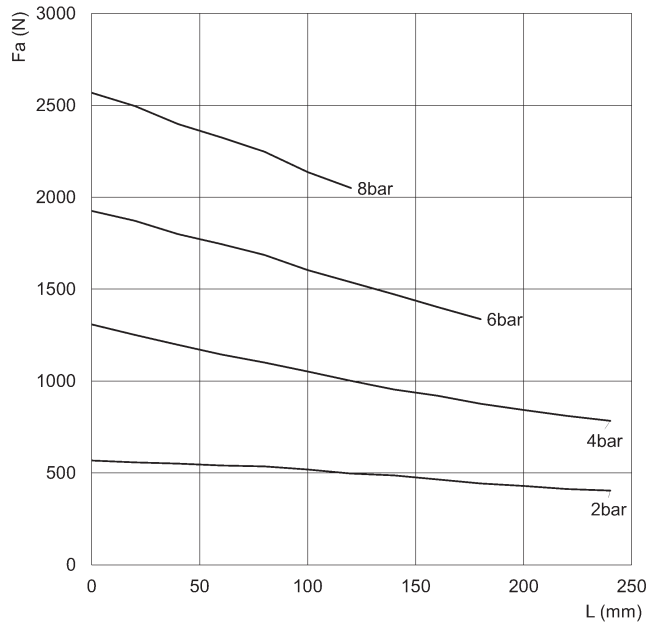

CGZT-160

Fa = opening gripping force
L = gripping point length

Examples of mounting

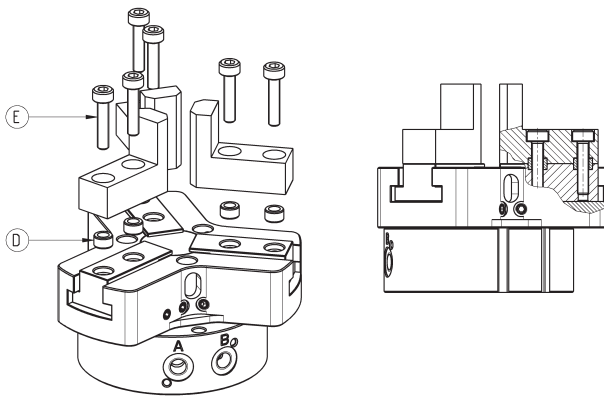
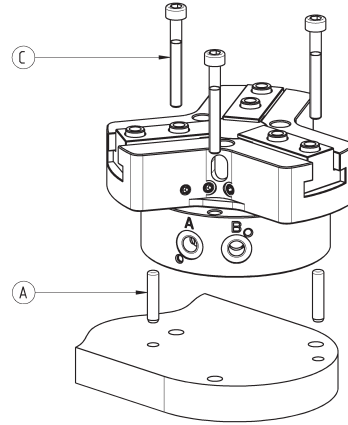
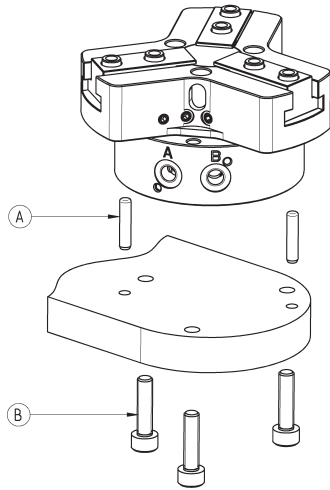

Mod.	A	B	C	D	E
CGZT-040	Ø2	M4	M3	Ø4	M2.5
CGZT-050	Ø3	M4	M3	Ø5	M3
CGZT-064	Ø4	M6	M5	Ø6	M4
CGZT-080	Ø5	M8	M6	Ø8	M5
CGZT-100	Ø5	M8	M6	Ø10	M6
CGZT-125	Ø6	M10	M8	Ø10	M6
CGZT-160	Ø6	M10	M8	Ø14	M10

Air supply ports

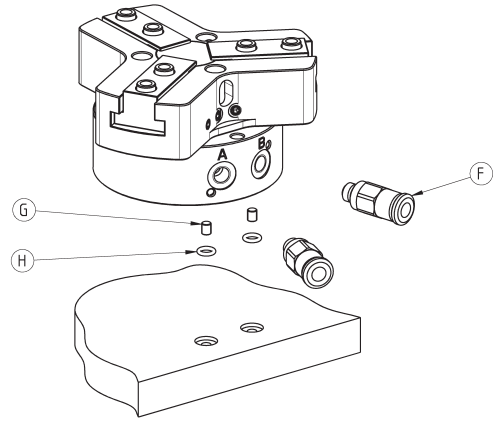

Mod.	F	G	H
CGZT-040	M3	M2	OR 1x2.5
CGZT-050	M5	M2.5	OR 1x3
CGZT-064	M5	M3	OR 1x3.5
CGZT-080	M5	M3	OR 1x3.5
CGZT-100	G1/8	M3	OR 1x3.5
CGZT-125	G1/8	M3	OR 1x3.5
CGZT-160	G1/8	M4	OR 1x4.5

Example of use of the pressurization/lubrication hole

Example of use of the lubrication (greasing) or pressurization hole of the zone with moving items

NOTE 1: grease the sliding zones using Molykote DX grease.

NOTE 2: supply a pressure of max 1 bar in order to avoid the sudden ejection of grease.

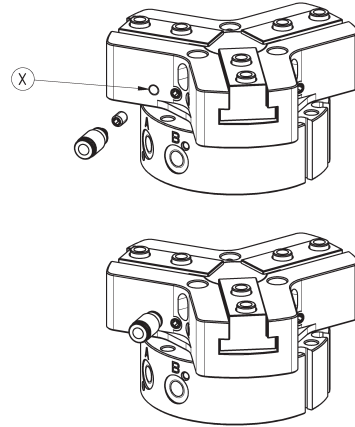

Mod.	X
CGZT-040	M3
CGZT-050	M3
CGZT-064	M5
CGZT-080	M5
CGZT-100	M5
CGZT-125	M5
CGZT-160	M5

Example of mounting: sensors

L = sensor Series CSD

In order to position the sensor correctly, a channel must be created in the base.

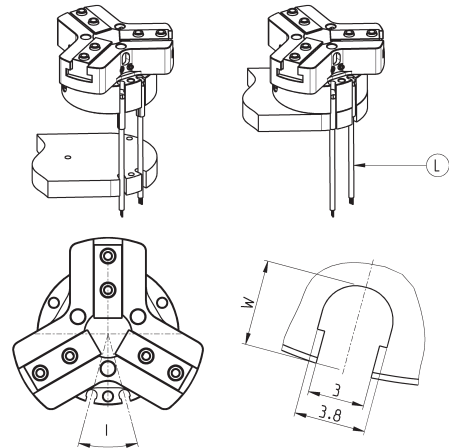

Mod.	I	W
CGZT-040	32°	4.5
CGZT-050	30°	4.6
CGZT-064	30°	6.5
CGZT-080	32°	8.7
CGZT-100	28°	9.3
CGZT-125	24°	11.5
CGZT-160	20°	12.5

Part retaining unit

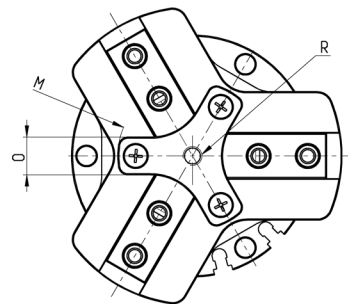
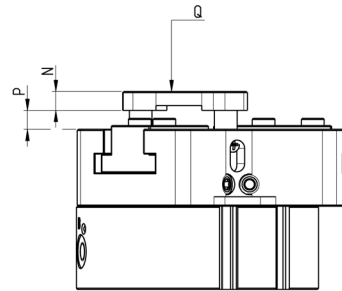
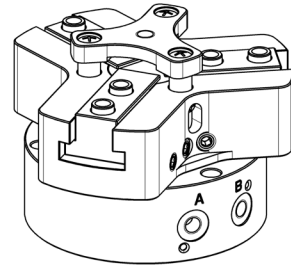
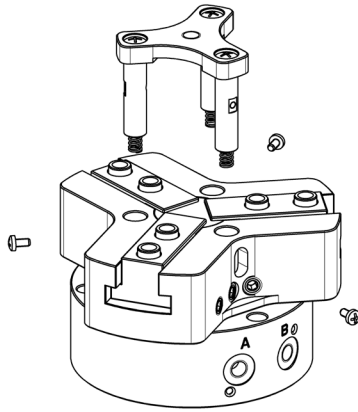

Mod.	M	N	O	P	Q	R
P-CGZT-040	Ø24	3.5	6	0 ÷ 2.5	10 N	M3
P-CGZT-050	Ø32.5	4.5	8	0 ÷ 3	14 N	M4
P-CGZT-064	Ø39.5	5	10	0 ÷ 5	21 N	M5
P-CGZT-080	Ø49	6	12.5	0 ÷ 5	32 N	M6
P-CGZT-100	Ø59	7	14	0 ÷ 5	48 N	M8
P-CGZT-125	Ø73	8	18	0 ÷ 6	85 N	M10
P-CGZT-160	Ø99	9.5	25	0 ÷ 6	185 N	M10