

Series 60 cylinders

Single and double-acting, magnetic, cushioned
Standard, low friction, low temperatures and tandem versions
Ø 32, 40, 50, 63, 80, 100, 125mm

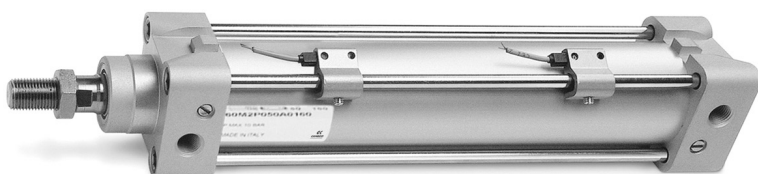

The Series 60 cylinders have been designed to comply with the dimensions laid down in the ISO 15552 standards. A permanent magnet, mounted on the piston, enables information to be received regarding the piston position by means of proximity switches positioned along the cylinder tube.

This cylinder series is normally equipped with adjustable end-stroke cushioning. Moreover, these cylinders are equipped with bumpers in order to reduce the impact of the piston as it reaches the end of the stroke.

- » In compliance with ISO 15552 standards and with the previous DIN/ISO 6431 - VDMA 24562 standards
- » Rolled stainless steel rod
- » Adjustable pneumatic cushioning
- » Available special versions

TANDEM:

- » Double thrust and traction forces

LOW FRICTION:

- » Friction force reduced by over 40%

LOW TEMPERATURES:

- » Versions for -40°C and for -50°C

G VARIANT FOR DUSTY APPLICATIONS:

- » Highly resistant to dust, cement, resin, mud, and wood residue

GENERAL DATA

Type of construction	with tie-rods
Operation	double-acting, single-acting, tandem. Low friction version: double-acting only.
Materials	standard: AL end-blocks and piston, rolled stainless steel AISI 420B rod, anodized AL tube, zinc-plated steel tie-rods and tie-rod nuts, PU seals; low friction: standard materials with NBR piston seals and NBR rod seal (FKM rod seal on request) low temperatures: standard materials with chrome plated stainless steel AISI 420B rod, brass rod scraper ring, stainless steel AISI 303 nuts, stainless steel AISI 420B tie-rods, PU piston seals and NBR rod seal
Type of mounting	with tie-rods, with front / rear flange, foot mounting, with centre / front / rear / swivel trunnion
Strokes min - max	10 ÷ 2500 mm
Operating temperature	standard and low friction: 0°C ÷ 80°C (with dry air - 20°C) low temperatures (-40°C version): -40°C ÷ 60°C (with dry air -40°C) low temperatures (-50°C version): -50°C ÷ 60°C (with dry air -50°C)
Operating pressure	1 ÷ 10 bar (standard and low temperatures); 0,1 ÷ 10 bar (low friction)
Speed	10 ÷ 1000 mm/sec, no load (standard and low temperatures); 5 ÷ 1000 mm/sec, no load (low friction)
Fluid	filtered air, without lubrication. For standard versions only: if lubricated air is used, it is recommended to use oil ISOVG32. Once applied the lubrication should never be interrupted.

STANDARD STROKES FOR CYLINDERS SERIES 60

■ = Single-acting (standard and low temperatures) ✕ = Double-acting (standard, low friction and low temperatures)
Other strokes up to 2500 mm are available on request.

∅	25	50	75	100	125	150	160	200	250	300	320	400	500
32	■ ✕	■ ✕	■ ✕	✕	✕	✕	✕	✕	✕	✕	✕	✕	✕
40	■ ✕	■ ✕	■ ✕	✕	✕	✕	✕	✕	✕	✕	✕	✕	✕
50	■ ✕	■ ✕	■ ✕	✕	✕	✕	✕	✕	✕	✕	✕	✕	✕
63	■ ✕	■ ✕	■ ✕	✕	✕	✕	✕	✕	✕	✕	✕	✕	✕
80	■ ✕	■ ✕	■ ✕	✕	✕	✕	✕	✕	✕	✕	✕	✕	✕
100		■ ✕	■ ✕	✕	✕	✕	✕	✕	✕	✕	✕	✕	✕
125		✕	✕	✕	✕	✕	✕	✕	✕	✕	✕	✕	✕

CODING EXAMPLE

60	M	2	L	050	A	0200	
-----------	----------	----------	----------	------------	----------	-------------	--

60	SERIES	
M	VERSIONS M = magnetic N = non magnetic L = low friction, magnetic	
2	OPERATION 1 = single-acting, front spring 2 = double-acting, front and rear cushioned 3 = double-acting, no cushion 4 = double-acting, rear cushioned 5 = double-acting, front cushioned 6 = double-acting, through-rod, front and rear cushioned 7 = single-acting, through-rod 8 = double-acting, through-rod, no cushion	PNEUMATIC SYMBOLS CS03 (N) - CS07 (M) CD02 (N) - CD09 (M) CD01 (N) - CD08 (M) CD03 (N) - CD10 (M) CD04 (N) - CD11 (M) CD06 (N) - CD13 (M) CS05 (N) - CS11 (M) CD12
L	MATERIALS L = see the GENERAL DATA table on the previous page T = stainless steel AISI 420B tie-rods, stainless steel AISI 303 tie-rod nuts, other materials (see the previous page) C = rolled stainless steel AISI 303 piston rod, stainless steel AISI 304 piston rod nut U = rolled stainless steel AISI 303 piston rod, AISI 304 piston-rod nut, AISI 420B tie-rods, AISI 303 tie-rod nuts W = rolled stainless steel AISI 304 piston rod, AISI 304 piston-rod nut, AISI 420B tie-rods, AISI 303 tie-rod nuts Z = chrome plated stainless steel AISI 420B rod, stainless steel AISI 304 rod nut, stainless steel AISI 420B tie-rods, stainless steel AISI 303 tie-rod nuts, seals for low temperatures (-40°C), brass rod scraper Y = chrome plated stainless steel AISI 420B rod, stainless steel AISI 304 rod nut, stainless steel AISI 420B tie-rods, stainless steel AISI 303 tie-rod nuts, seals for low temperatures (-50°C), brass rod scraper	
050	BORE 032 = 32 mm 040 = 40 mm 050 = 50 mm 063 = 63 mm 080 = 80 mm 100 = 100 mm 125 = 125 mm	
A	CONSTRUCTION A = standard with lock nut for rod RL = cylinder with rod lock F = cylinder with centre trunnion	
0200	STROKE (see the table)	
	= standard V = FKM rod seal N = tandem R = NBR rod seal W = all FKM seals + 130°C C = PU coated cylinder. Colour: Grey * L = low friction version without rod seal (rear supply only) ** (_ _ _) = extended piston rod _ _ _ mm G = with brass rod scraper (chrome plated stainless steel AISI 420B rod, NBR rod seal)	CD8T (M) - CD9T (N)
	* Version C: available on request. For further information, please contact our technical dept. ** The possibility to order the cylinder without piston rod seal, further reduces the friction force.	

Note: all double-acting cylinders are also available in the low friction version.

PNEUMATIC SYMBOLS [Pneumatic symbols in the CODING EXAMPLE are shown below.]

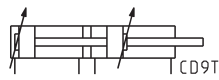
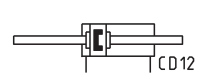
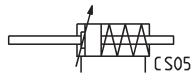
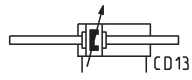
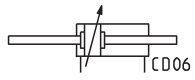
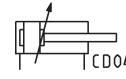
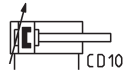
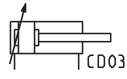
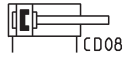
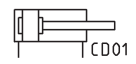
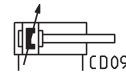
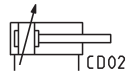

Series 60 low friction cylinders - APPLICATION EXAMPLES

SERIES 60 CYLINDERS

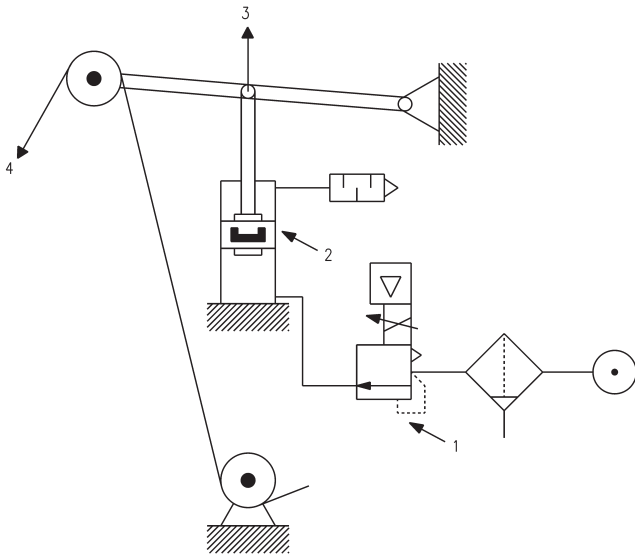

CYLINDER IN THRUST

DRAWING NOTES:

- 1. Precision pressure regulator or proportional regulator
- 2. Low friction cylinder
- 3. Force direction
- 4. Band

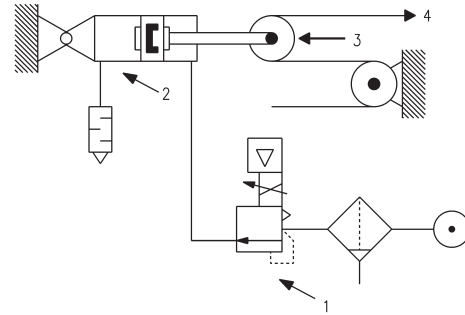

CYLINDER IN TRACTION

Note: in order to reach the highest performance, it is recommended to connect a precision pressure regulator or a proportional regulator with the low friction cylinder as shown in the drawing.

Series 60 low temperatures cylinders - DETAIL

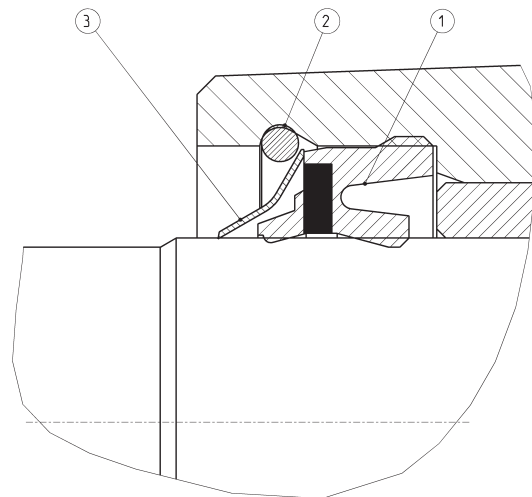
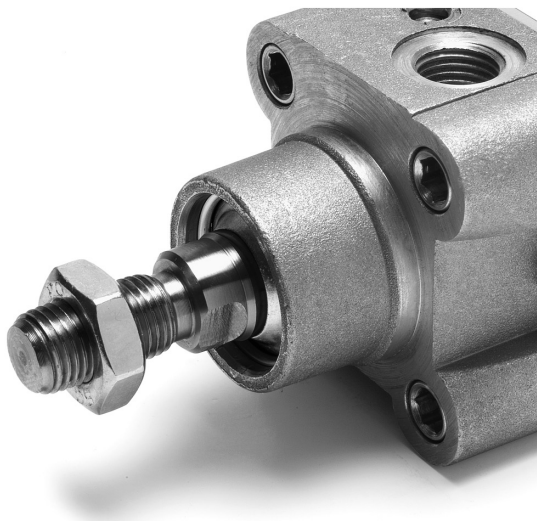

- 1 = rod seal
- 2 = flexible ring
- 3 = metal scraper

ACCESSORIES FOR CYLINDERS SERIES 60



Piston rod socket joint
Mod. GY



Piston rod lock nut
Mod. U



Clevis pin Mod. S

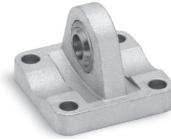

Rear trunnion ball-joint
Mod. R

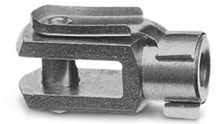

Rod fork end Mod. G



Swivel ball joint Mod. GA

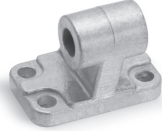

90° male trunnion
Mod. ZC

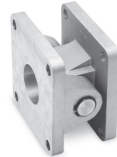

Swivel combination
Mod. C+L+S



Centre trunnion Mod. F



Self aligning rod
Mod. GK



Counter bracket for
centre trunnion Mod. BF



Foot mount Mod. B

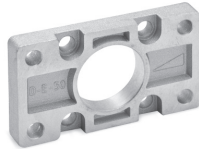

Front and rear flange Mod.
D-E

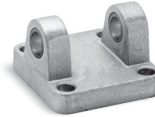

Rear female trunnion
Mod. C and C-H



Front female trunnion
Mod. H and C-H

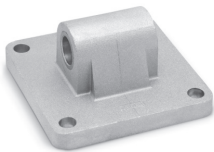

Rear male trunnion
Mod. L



Coupling piece
Mod. GKF

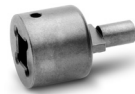

Key to disassemble
cylinders Ø 80 and 100



All accessories are supplied separately, except for piston rod lock nut Mod. U

Cylinders Series 60

Note: the single-acting cylinders' sizes ZJ and L2 are increased by 25 mm.

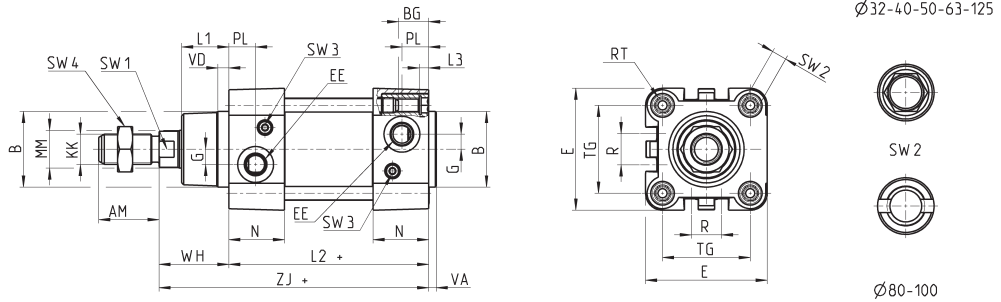

+ = add the stroke

Table note:
* = special key 80-62/8C (see accessories)

SERIES 60 CYLINDERS

DIMENSIONS																									
Ø	AM	B	BG	E	EE	G	KK	L1	L2+	L3	MM	N	PL	R	RT	SW1	SW2	SW3	SW4	TG	VA	VD	WH	ZJ+	Front/rear cushion stroke
32	22	30	16	46	G1/8	5	M10x1,25	18	94	5	12	26	14	13	M6	10	6	2	17	32,5	4	5	26	120	17 / 12
40	24	35	16	55	G1/4	5	M12x1,25	21	105	5	16	29	15	13,5	M6	13	6	2	19	38	4	5	30	135	20 / 17
50	32	40	16	64,5	G1/4	8	M16x1,5	25	106	5	20	29,5	15	16	M8	17	8	3	24	46,5	4	6	37	143	15 / 14
63	32	45	16	75	G3/8	8	M16x1,5	26	121	5	20	36,5	21	28	M8	17	8	3	24	56,5	4	6	37	158	17 / 16
80	40	45	19	93	G3/8	8	M20x1,5	30	128	0	25	36	21	30	M10	22	*	5	30	72	4	7	46	174	20 / 20
100	40	55	19,5	110	G1/2	8	M20x1,5	35	138	0	25	38,5	23	40	M10	22	*	5	30	89	4	7	51	189	21 / 19
125	54	60	23	135	G1/2	10,5	M27x2	42	160	0	32	43	23,5	50	M12	27	12	4	41	110	6	8	65	225	26 / 25

Cylinders Series 60 - through-rod

Note: the single-acting cylinders' sizes ZM and L2 are increased by 25 mm.

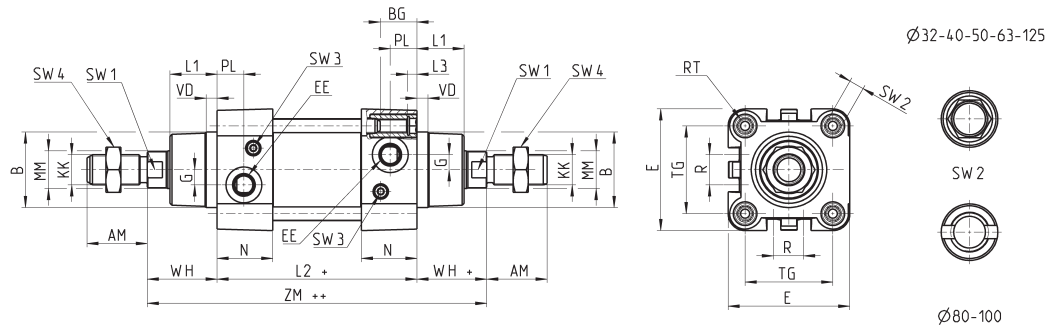

+ = add the stroke once
++ = add the stroke twice

Table note:
* = special key 80-62/8C (see accessories)

DIMENSIONS																									
Ø	AM	B	BG	E	EE	G	KK	L1	L2+	L3	MM	N	PL	R	RT	SW1	SW2	SW3	SW4	TG	VD	WH	ZM++	Front/rear cushion stroke	
32	22	30	16	46	G1/8	5	M10x1,25	18	94	5	12	26	14	13	M6	10	6	2	17	32,5	5	26	146	17 / 12	
40	24	35	16	55	G1/4	5	M12x1,25	21	105	5	16	29	15	13,5	M6	13	6	2	19	38	5	30	165	20 / 17	
50	32	40	16	64,5	G1/4	8	M16x1,5	25	106	5	20	29,5	15	16	M8	17	8	3	24	46,5	6	37	180	15 / 14	
63	32	45	16	75	G3/8	8	M16x1,5	26	121	5	20	36,5	21	28	M8	17	8	3	24	56,5	6	37	195	17 / 16	
80	40	45	19	93	G3/8	8	M20x1,5	30	128	0	25	36	21	30	M10	22	*	5	30	72	7	46	220	20 / 20	
100	40	55	19,5	110	G1/2	8	M20x1,5	35	138	0	25	38,5	23	40	M10	22	*	5	30	89	7	51	240	21 / 19	
125	54	60	23	135	G1/2	10,5	M27x2	42	160	0	32	43	23,5	50	M12	27	12	4	41	110	8	65	290	26 / 25	

Cylinders Series 60 - tandem version



+ = add the stroke once
 ++ = add the stroke twice
 1 = Cylinder's outlet
 2 = Cylinder's return

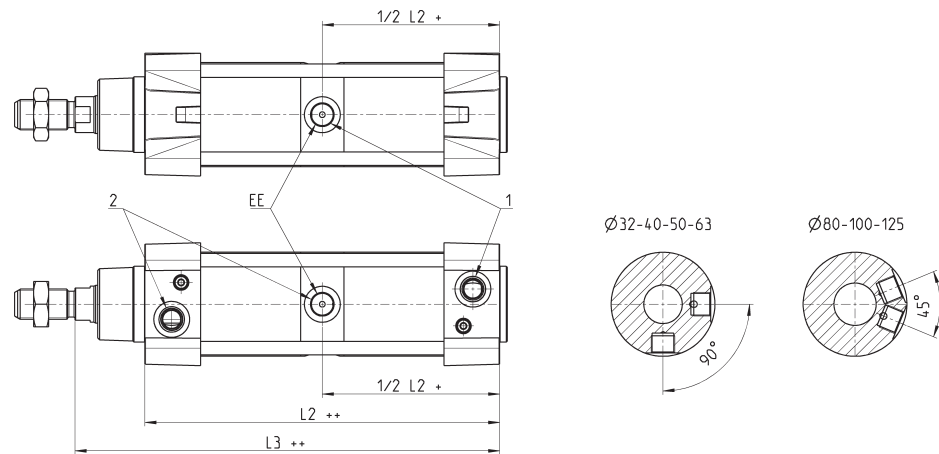

DIMENSIONS			
∅	EE	L2	L3
32	G1/8	171,5	197,5
40	G1/4	191,5	221,5
50	G1/4	188	225
63	G3/8	204	241
80	G3/8	225,5	271,5
100	G1/2	231	282
125	G1/2	264	329

Cylinders Series 60 with rod lock



+ = add the stroke

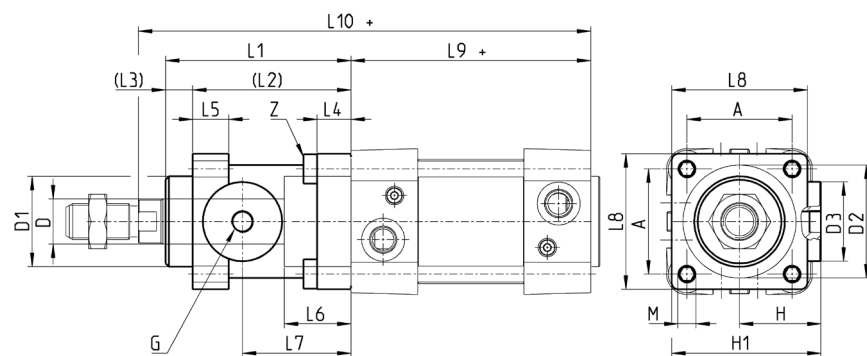

DIMENSIONS																					
∅	∅ _D	∅ _{D1}	∅ _{D2}	∅ _{D3}	A	G	H	H1	L1	L2	L3	L4	L5	L6	L7	L8	L9+	L10+	M	Z	
32	12	30,5	35	25	32,5	M5	25,5	46,5	58	48	10	8	13	20,5	34	45	94	160	M6	M6X20	
40	16	35	40	28	38	G1/8	30	53	65	55	10	8	13	22,5	38	50	105	178	M6	M6X20	
50	20	40	50	35	46,5	G1/8	36	64	82	70	12	15	16	29,5	48	60	106	200	M8	M8X30	
63	20	45	60	38	56,5	G1/8	40	75	82	70	12	15	16	29,5	49,5	70	121	215	M8	M8X30	
80	25	45	80	48	72	G1/8	50	95	110	90	20	18	20	35	61	90	128	254	M10	M10X35	
100	25	55	100	58	89	G1/8	58	110,5	115	100	15	18	20	39	69	105	138	269	M10	M10X35	
125	32	60	130	65	110	G1/8	80	150	167	122	45	22	30	51	86,5	140	160	350	M12	M12X40	

Foot mount Mod. B

Material: zinc-plated steel



Supplied with:
2x feet
4x screws
+ = add the stroke

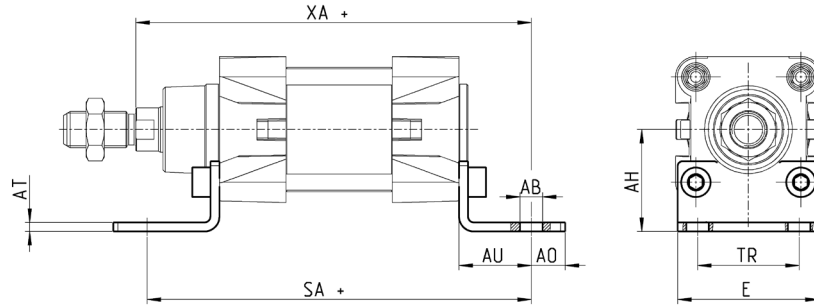

DIMENSIONS											
Mod.	∅	AT	SA+	XA+	TR	E	AB	AH	A0	AU	torque force
B-41-32	32	4	142	144	32	45	7	32	11	24	6 Nm
B-41-40	40	4	161	163	36	53,5	10	36	15	28	6 Nm
B-41-50	50	4	170	175	45	62,5	10	45	15	32	13 Nm
B-41-63	63	5	185	190	50	73	10	50	15	32	13 Nm
B-41-80	80	6	210	216	63	92	12	63	20	41	19 Nm
B-41-100	100	6	220	230	75	108,5	14,5	71	25	41	22 Nm
B-41-125	125	7	250	270	90	132	16,5	90	25	45	26 Nm

Front and rear flange Mod. D-E

Material: Aluminium

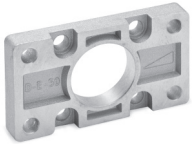

Supplied with:
1x flange
4x screws
+ = add the stroke

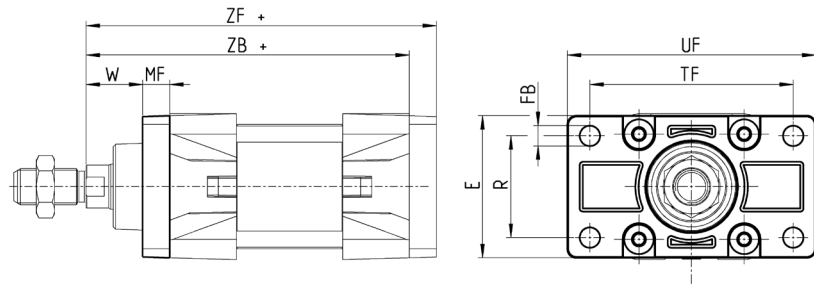

DIMENSIONS											
Mod.	∅	W	MF	ZB	TF	R	UF	E	FB	ZF	torque force
D-E-41-32	32	16	10	120	64	32	86	45	7	130	6 Nm
D-E-41-40	40	20	10	135	72	36	88	52	9	145	6 Nm
D-E-41-50	50	25	12	143	90	45	110	63	9	155	13 Nm
D-E-41-63	63	25	12	158	100	50	116	73	9	170	13 Nm
D-E-41-80	80	30	16	174	126	63	148	95	12	190	19 Nm
D-E-41-100	100	35	16	189	150	75	176	115	14	205	22 Nm
D-E-41-125	125	45	20	225	180	90	224	135	16	245	26 Nm

Rear female trunnion Mod. C and C-H

Material: Aluminium

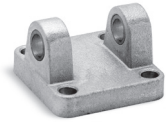

Supplied with:
1x female trunnion
4x screws

+ = add the stroke

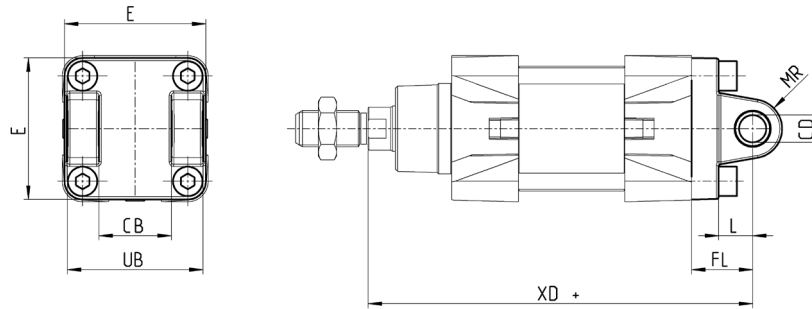

DIMENSIONS										
Mod.	∅	CD	L	FL	XD+	MR	E	CB	UB	torque force
C-41-32	32	10	12	22	142	10	45	26	45	6 Nm
C-41-40	40	12	15	25	160	12	53.5	28	52	6 Nm
C-41-50	50	12	15	27	170	13	62.5	32	60	13 Nm
C-H-41-63	63	16	20	32	190	17	73	40	70	13 Nm
C-H-41-80	80	16	24	36	210	17	92	50	90	19 Nm
C-H-41-100	100	20	29	41	230	21	108.5	60	110	22 Nm
C-H-41-125	125	25	30	50	275	26	132	70	130	26 Nm

Front female trunnion Mod. H and C-H

Material: Aluminium



Supplied with:
1x trunnion
4x screws

+ = add the stroke

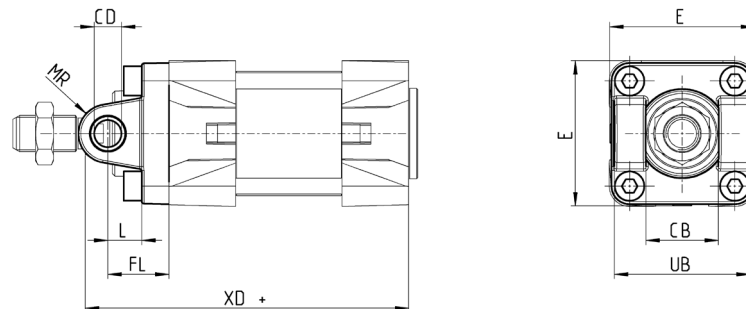

DIMENSIONS									
Mod.	CB	UB	E	XD+	FL	L	CD	MR	torque force
H-41-32	26	45	45	120	22	12	10	10	6 Nm
H-41-40	28	52	53.5	135	25	15	12	12	6 Nm
H-41-50	32	60	62.5	143	27	15	12	13	13 Nm
H-60-63	40	70	73	158	32	20	16	17	13 Nm
C-H-41-80	50	90	92	174	36	24	16	17	19 Nm
C-H-41-100	60	110	108.5	189	41	29	20	21	22 Nm
C-H-41-125	70	130	132	225	50	30	25	26	26 Nm

Rear male trunnion Mod. L

Material: Aluminium

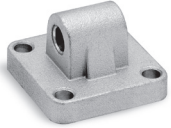

Supplied with:
2x male trunnions
4x screws

+ = add the stroke

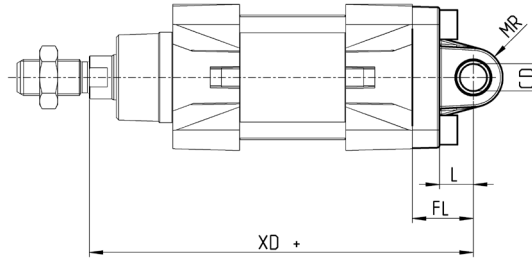
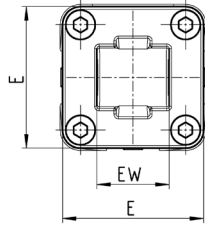

DIMENSIONS

Mod.	∅	CD	L	FL	XD+	MR	E	EW	torque force
L-41-32	32	10	12	22	142	10	45	26	6 Nm
L-41-40	40	12	15	25	160	13	53.5	28	6 Nm
L-41-50	50	12	15	27	170	13	62.5	32	13 Nm
L-41-63	63	16	20	32	190	17	73	40	13 Nm
L-41-80	80	16	24	36	210	17	92	50	19 Nm
L-41-100	100	20	29	41	230	21	108.5	60	22 Nm
L-41-125	125	25	30	50	275	26	132	70	26 Nm

Centre trunnion Mod. F

Material: zinc-plated steel



Supplied with:
1x intermediate trunnion
8x locking screws

+ = add the stroke

+1/2 = add half of the stroke

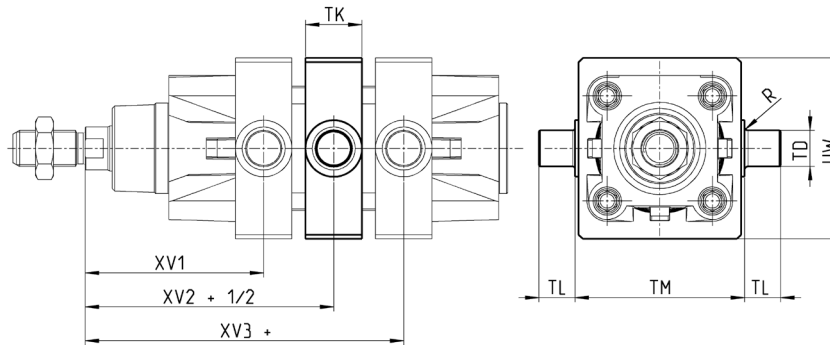

DIMENSIONS

Mod.	∅	XV1	XV2	XV3	TM (h14)	TK	TD (e9)	TL	UW	R
F-32	32	62	73	84	50	20	12	12	50	0.5
F-40	40	69	82,5	96	63	20	16	16	60	1
F-50	50	79	90	101	75	25	16	16	70	1
F-63	63	86	97,5	109	90	25	20	20	85	1
F-80	80	97	110	123	110	30	20	20	105	1
F-100	100	104,5	120	135,5	132	30	25	25	125	1.5
F-125	125	123	145	167	160	30	25	25	155	1.5

Accessory combination Mod. C+L+S

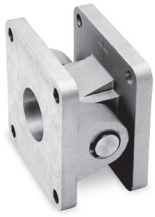

Material: Aluminium

+ = add the stroke

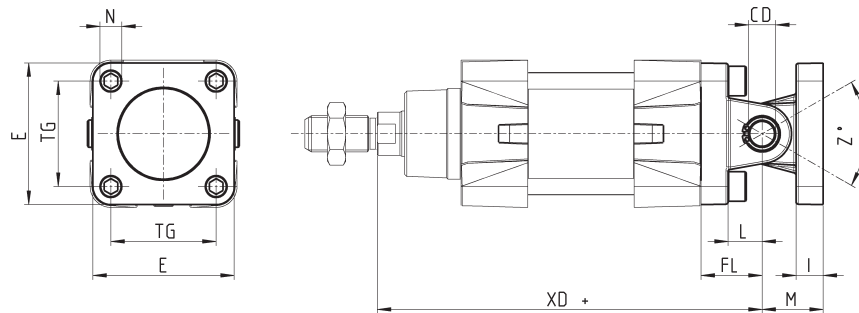

DIMENSIONS												
Mod.	∅	E	TG	\varnothing N	XD+	\varnothing CD	L	FL	I	M	Z° (max)	torque force
C+L+S	32	45	32.5	6.5	142	10	12	22	10	22	30	6 Nm
C+L+S	40	53.5	38	6.5	160	12	15	25	10	25	40	6 Nm
C+L+S	50	62.5	46.5	9	170	12	15	27	12	27	25	13 Nm
C+L+S	63	73	56.5	9	190	16	20	32	12	32	36	13 Nm
C+L+S	80	92	72	11	210	16	24	36	12	36	34	19 Nm
C+L+S	100	108.5	89	11	230	20	29	41	12	41	38	22 Nm
C+L+S	125	132	110	13	275	25	30	50	20	50	30	26 Nm

90° male trunnion Mod. ZC

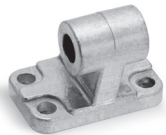

CETOP RP 107P
Material: aluminium

Supplied with:
1x male trunnion

+ = add the stroke

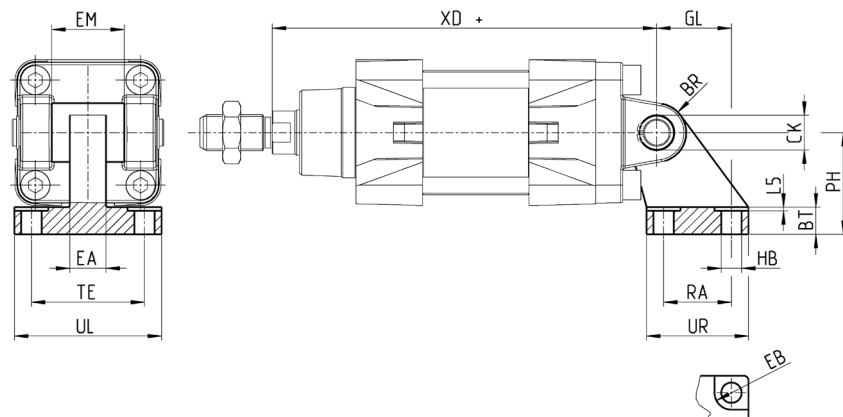

DIMENSIONS																
Mod.	∅	EB	\varnothing CK	HB	XD+	TE	UL	EA	GL	L5	RA	EM	UR	PH	BT	BR
ZC-32	32	11	10	6,6	142	38	51	10	21	1,6	18	26	31	32	8	10
ZC-40	40	11	12	6,6	160	41	54	15	24	1,6	22	28	35	36	10	11
ZC-50	50	15	12	9	170	50	65	16	33	1,6	30	32	45	45	12	13
ZC-63	63	15	16	9	190	52	67	16	37	1,6	35	40	50	50	14	15
ZC-80	80	18	16	11	210	66	86	20	47	2,5	40	50	60	63	14	15
ZC-100	100	18	20	11	230	76	96	20	55	2,5	50	60	70	71	17	19
ZC-125	125	20	25	14	275	94	124	30	70	3,2	60	70	90	90	20	22,5

Rear trunnion ball-joint Mod. R*

* This trunnion doesn't comply with the ISO 15552 standard
Material: Aluminium

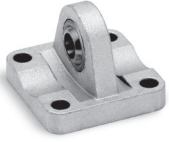

Supplied with:
1x trunnion ball joint
4x screws

+ = add the stroke

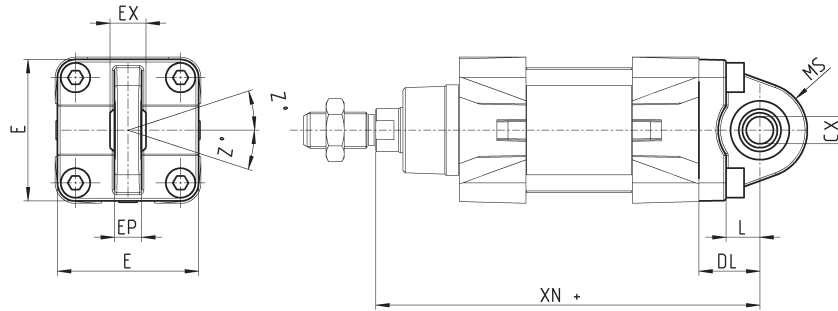

DIMENSIONS											
Mod.	∅	_g CX	L	DL	XN+	MS	E	EX	EP	Z	torque force
R-41-32	32	10	12	22	142	18	45	14	10,5	4	6 Nm
R-41-40	40	12	15	25	160	18	53.5	16	12	4	6 Nm
R-41-50	50	12 *	15	27	170	21	62.5	16 *	12 *	4	13 Nm
R-41-63	63	16	20	32	190	23	73	21	15	4	13 Nm
R-41-80	80	16 *	24	36	210	28	92	21 *	15 *	4	19 Nm
R-41-100	100	20	29	41	230	30	108.5	25	18	4	22 Nm
R-41-125	125	30	30	50	275	40	140	37	25	4	26 Nm

Counter bracket for centre trunnion Mod. BF

Material: aluminium

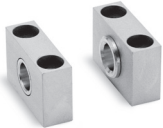

Supplied with:
2x supports

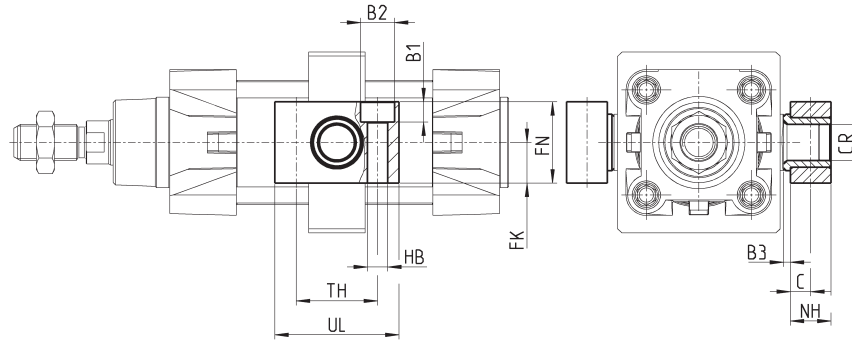

DIMENSIONS											
Mod.	CR	NH	C	b3	TH	UL	FK	FN	B1	B2	HB
BF-32	12	15	7,5	3	32	46	15	30	6,8	11	6,6
BF-40-50	16	18	9	3	36	55	18	36	9	15	9
BF-63-80	20	20	10	3	42	65	20	40	11	18	11
BF-100-125	25	25	12,5	3,5	50	75	25	50	13	20	14

Clevis pin Mod. S



Supplied with:
1x clevis pin in stainless steel 303
2x Seeger in steel

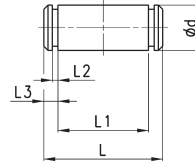

DIMENSIONS						
Mod.	Ø	d	L	L1	L2	L3
S-32	32	10	52	46	1,1	3
S-40	40	12	59	53	1,1	3
S-50	50	12	67	61	1,1	3
S-63	63	16	77	71	1,1	3
S-80	80	16	97	91	1,1	3
S-100	100	20	121	111	1,3	5
S-125	125	25	140,5	132	1,3	4,25

Accessory for mounting valves on the cylinder

The mounting sub-base Mod. PCV enables the valve to be mounted directly on the cylinder and it's fixed on it using screws Mod. 1635 or flow controllers, Mod. SCU. The other end of the plate has a threaded port.



d* = mounting on the cylinder using Mod. 1635 or Mod. SCU.

Note: the minimum possible stroke is 100mm.

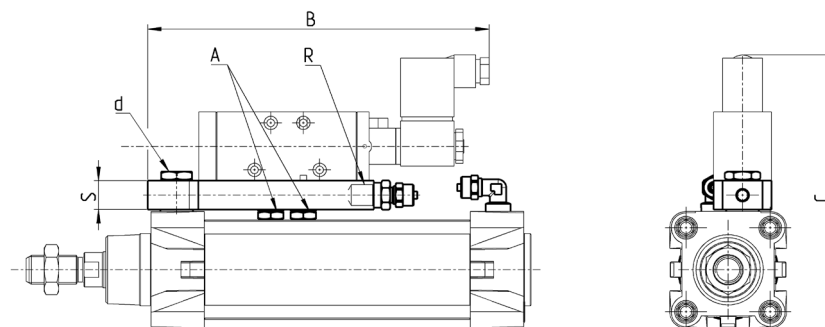

DIMENSIONS							
Mod.	Ø	A	B	C	R	S	d*
PCV-32	32	G1/8	185	131,5	G1/8	16	G1/8
PCV-40-50	40	G1/8	188,5	140,5	G1/4	16	G1/4
PCV-40-50	50	G1/8	188,5	150	G1/4	16	G1/4
PCV-63-80	63	G1/4	215	167	G1/4	16	G3/8
PCV-63-80	80	G1/4	215	185	G1/4	16	G3/8

Rod fork end Mod. G

ISO 8140
Material: zinc-plated steel

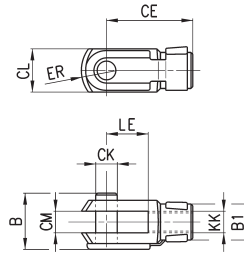
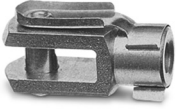

DIMENSIONS										
	CK	LE	CM	CL	ER	CE	KK	B	B1	
G-25-32	10	20	10	20	12	40	M10X1,25	26	18	
G-40	12	24	12	24	14	48	M12X1,25	32	20	
G-50-63	16	32	16	32	19	64	M16X1,5	40	26	
G-80-100	20	40	20	40	25	80	M20X1,5	48	34	
G-41-125	30	54	30	55	38	110	M27X2	74	48	

Swivel ball joint Mod. GA

ISO 8139.
Material: zinc-plated steel.

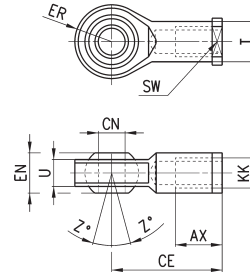

DIMENSIONS												
Mod.	∅	∅ ₁ CN ⁽¹⁷⁾	U	EN	ER	AX	CE	KK	∅ ₂ T	Z	SW	
GA-32	32	10	10,5	14	14	20	43	M10X1,25	15	6,5	17	
GA-40	40	12	12	16	16	22	50	M12X1,25	17,5	6,5	19	
GA-50-63	50-63	16	15	21	21	28	64	M16X1,5	22	7,5	22	
GA-80-100	80-100	20	18	25	25	33	77	M20x1,5	27,5	7	30	
GA-41-125	125	30	25	37	35	51	110	M27x2	40	7,5	41	

Piston rod socket joint Mod. GY

Material: zama and zinc-plated steel.

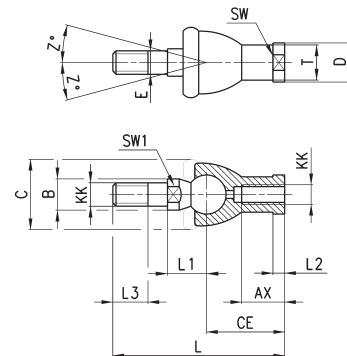

DIMENSIONS																
Mod.	∅	KK	L	CE	L2	AX	SW	SW1	L1	L3	∅ ₁ T	∅ ₂ D	E	∅ ₃ B	∅ ₄ C	Z
GY-32	32	M10X1,25	74	35	6,5	18	17	11	19,5	15	15	19	10	14	28	15
GY-40	40	M12X1,25	84	40	6,5	20	19	17	21	17	17,5	22	12	19	32	15
GY-50-63	50-63	M16X1,5	112	50	8	27	22	19	27,5	23	22	27	16	22	40	11
GY-80-100	80-100	M20x1,5	133	63	10	38	30	24	31,5	25	27,5	34	20	27	45	7,5

Piston rod lock nut Mod. U



ISO 4035
Material: zinc-plated steel

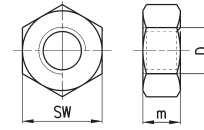

DIMENSIONS				
Mod.	∅	D	m	SW
U-25-32	32	M10X1,25	6	17
U-40	40	M12X1,25	7	19
U-50-63	50-63	M16X1,5	8	24
U-80-100	80-100	M20X1,5	9	30
U-41-125	125	M27X2	12	41

Self aligning rod Mod. GK



Material: zama and zinc-plated steel.

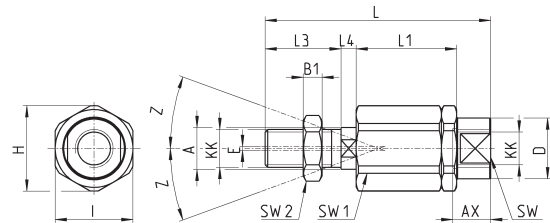

DIMENSIONS																	
Mod.	∅	KK	L	L1	L3	L4	A	D	H	I	SW	SW1	SW2	B1	AX	Z	E
GK-25-32	32	M10X1,25	71,5	35	20	7,5	14	22	32	30	19	12	17	5	22	4	2
GK-40	40	M12X1,25	75,5	35	24	7,5	14	22	32	30	19	12	19	6	22	4	2
GK-50-63	50-63	M16X1,5	104	53	32	10	22	32	45	41	27	20	24	8	30	3	2
GK-80-100	80-100	M20x1,5	119	53	40	10	22	32	45	41	27	20	30	10	37	3	2
GK-125	125	M27x2	147	60	54	10	32	57	70	65	54	24	41	12	48	4	2

Coupling piece Mod. GKF



Material: zinc-plated steel.

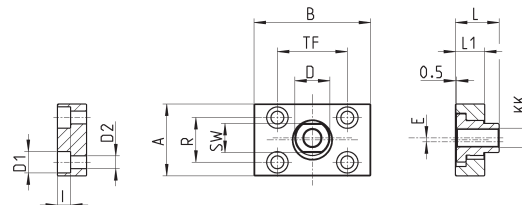

DIMENSIONS														
Mod.	∅	KK	A	B	R	TF	L	L1	I	∅ D	∅ D1	∅ D2	SW	E
GKF-25-32	32	M10x1,25	37	60	23	36	22,5	15	6,8	18	11	6,6	15	2
GKF-40	40	M12x1,25	56	60	38	42	22,5	15	9	20	15	9	15	2,5
GKF-50-63	50-63	M16x1,5	80	80	58	58	26,5	15	10,5	25	18	11	22	2,5
GKF-80-100	80-100	M20x1,5	90	90	65	65	32,5	20	13	30,5	20	14	27	2,5
GKF-125	125	M27x2	90	90	65	65	35,5	20	13	40	20	14	36	4

Special key to disassemble cylinders Ø 80 and 100

Material: hardened steel.

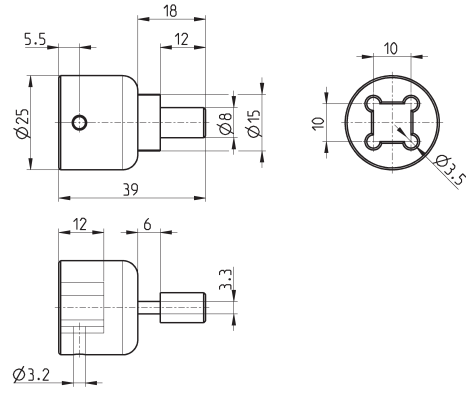

SERIES 60 CYLINDERS

Mod.
80-62/8C