

Series 63 ISO 15552 cylinders



Single and double-acting, magnetic, cushioned
 ø 32, 40, 50, 63, 80, 100, 125 mm



The Series 63 pneumatic cylinders have been developed to guarantee high performance and versatility. Thanks to a new system of adjustable pneumatic cushioning, the cylinders can always guarantee the best regulation whilst significantly reducing noise caused by the impact of the piston on the end block.

Besides the standard version, which can be used in many sectors, specific solutions have been developed for applications such as food processing, agriculture, in tensioning, dosing systems and dancer arms for winding applications. There are also versions for demanding application environments, capable of withstanding extreme temperatures, corrosive atmospheres etc.

- » In compliance with the ISO 15552 standard
- » Weight reduced by 25%
- » Low noise
- » More accurate with fine regulation of cushioning
- » Flexibility and versatility

VERSIONS AVAILABLE:

- » Low friction
- » Uniform movement (low speed)
- » High and low temperatures
- » Corrosion-resistant
- » Hydrolytic environment
- » Food and beverage
- » Lube-free operation
- » Dirty and dusty environments
- » Protective bellows
- » Back to back
- » Tandem and multi-position
- » With rod lock
- » Polyurethane coating
- » ATEX

GENERAL DATA

Type of construction	profile (with screws) and round tube (with tie-rods)
Design	ISO 15552
Operation	single and double-acting
Type of mounting	with front / rear flange, foot mounting, with front / rear / centre / swivel trunnion
Stroke min - max	10 ÷ 2500 mm
Operating temperature	standard and low friction: 0°C ÷ 80°C (with dry air -20°C) high temperatures (version W): 0°C ÷ 150°C (with dry air -20°C) low temperatures (version Z): -40°C ÷ 60°C (with dry air -40°C) low temperatures (version Y): -50°C ÷ 60°C (with dry air -50°C)
Storage temperature	0°C ÷ 80°C (with dry air -20°C)
Operating pressure	1 ÷ 10 bar (standard, high and low temperatures) 0.1 ÷ 10 bar (low friction)
Speed	10 ÷ 1000 mm/sec, no load (standard, high and low temperatures) 5 ÷ 1000 mm/sec, no load (low friction and uniform movement)
Fluid	filtered air in class 7.8.4, according to ISO 8573-1. If lubricated air is used, it is recommended to use oil ISOVG32. Once applied the lubrication should never be interrupted.
Use with sensors	model CSH

STANDARD STROKES FOR CYLINDERS SERIES 63

■ = Single-acting, front spring (standard and high temperatures); ▲ = Single-acting, rear spring (standard and high temperatures);
 ✕ = Double-acting (standard, low friction, high/low temperatures) Other strokes up to 2500 mm are available on request.

STANDARD STROKES														
Ø	25	50	75	80	100	125	150	160	200	250	300	320	400	500
32	■ ▲ ✕	■ ▲ ✕	■ ✕	✕	✕	✕	✕	✕	✕	✕	✕	✕	✕	✕
40	■ ▲ ✕	■ ▲ ✕	■ ✕	✕	✕	✕	✕	✕	✕	✕	✕	✕	✕	✕
50	■ ▲ ✕	■ ▲ ✕	■ ✕	✕	✕	✕	✕	✕	✕	✕	✕	✕	✕	✕
63	■ ▲ ✕	■ ▲ ✕	■ ✕	✕	✕	✕	✕	✕	✕	✕	✕	✕	✕	✕
80	■ ▲ ✕	■ ▲ ✕	■ ✕	✕	✕	✕	✕	✕	✕	✕	✕	✕	✕	✕
100		■ ▲ ✕	■ ✕	✕	✕	✕	✕	✕	✕	✕	✕	✕	✕	✕
125		■ ▲ ✕	■ ✕	✕	✕	✕	✕	✕	✕	✕	✕	✕	✕	✕

CODING EXAMPLE

63	M	P	2	C	050	A	0200	W						
-----------	----------	----------	----------	----------	------------	----------	-------------	----------	--	--	--	--	--	--

63	SERIES	
M	VERSION: M = standard, magnetic V = uniform movement (no stick slip), magnetic L = low friction, magnetic	
P	CONSTRUCTION: T = round tube P = profile	
2	OPERATION: 1 = single-acting, front spring 2 = double-acting 6 = double-acting, through-rod 7 = single-acting, through-rod 9 = single-acting, rear spring	PNEUMATIC SYMBOLS: CS07/CS18 CD08 - CD09 - CD10 - CD11 CD13 CS11 CS14/CS17
C	CUSHIONING: N = no cushioning (mechanical endstops) C = cushioning on both sides F = front cushioning R = rear cushioning	PNEUMATIC SYMBOLS: CD08 CD09/CD13 CD11 CD10
050	BORE: 032 = 32 mm 040 = 40 mm 050 = 50 mm 063 = 63 mm	080 = 80 mm 100 = 100 mm 125 = 125 mm
A	CONSTRUCTIVE TYPE: A = standard with rod nut RL = cylinder with rod lock	DC = back to back cylinder with DC accessory [X1/X2] TR = back to back cylinder for round tube [X1/X2] F = cylinder with centre trunnion
0200	STROKE: = standard N = tandem / = more positions X1/X2 [X1<X2]	
W	TEMPERATURE RANGE: = standard (-20°/+80°) W = high temperatures (150°C)	Z = low temperatures (-40°C) Y = low temperatures (-50°C)
	RESISTANCE TO CORROSION: = standard C1 = rod nut AISI 304 stainless steel, rod AISI 304 stainless steel C2 = end cap treated screws (profile) or AISI 303 tie-rods and AISI 420B tie-rods (round tube)	C3 = C2 + AISI 316 rod nut, AISI 316 rod C4 = C1 + C2 C5 = C3 + end caps with triple protection
	ROD VARIATIONS: = standard (male rod thread) F = female rod thread K = end caps with Kanigen treatment L = without rod seal (rear air inlet only)* V = FKM rod seal R = NBR rod seal U = unlubricated operation	H = hydrolytic environment A = use in food and other frequent washdown applications G = dry and dusty environments (with brass rod scraper and chrome-plated stainless steel AISI 420B rod) B = cylinder with NBR bellows rod protection (___) = extended rod ___ mm
	OTHER: P = cylinder with RAL 7035 polyurethane coating	
	CERTIFICATIONS: EX = ATEX	

* Only for low friction

PNEUMATIC SYMBOLS

The pneumatic symbols which have been indicated in the CODING EXAMPLE are shown below.

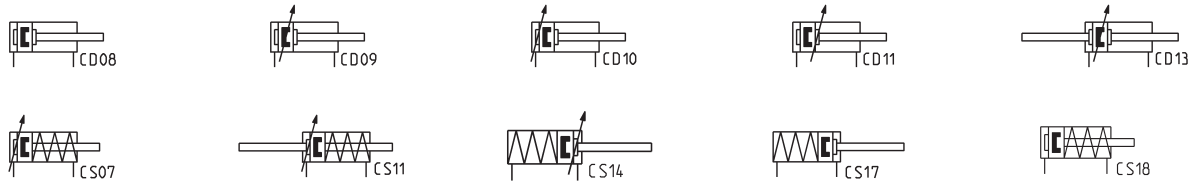

MATERIALS

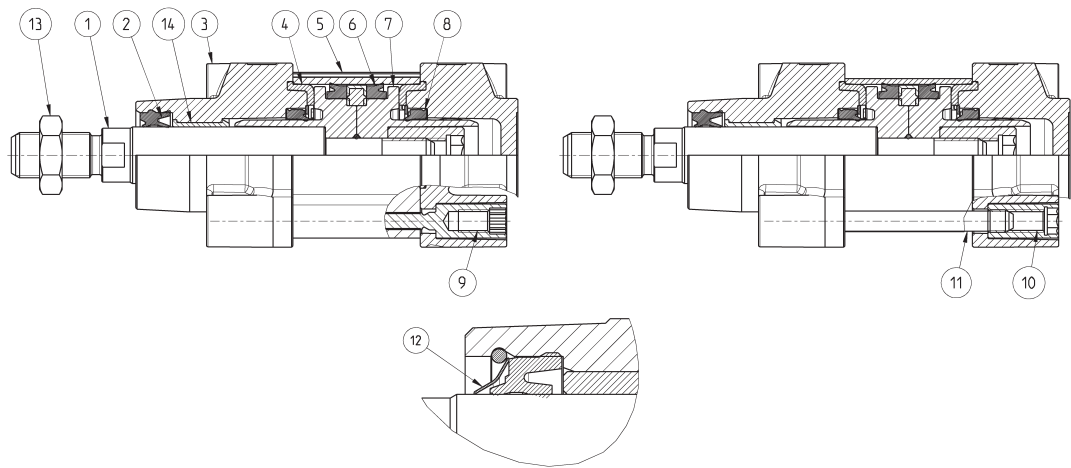

LIST OF COMPONENTS							
	Standard, profile	Standard, round tube	Low friction (L)	Rod scraper (G)	Low temperatures (Z/Y)	High temperatures (W)	Resistance to corrosion (C1)
PARTS							
1 - Rod	AISI 420B	AISI 420B	AISI 420B	Chrome-plated AISI 420B	Chrome-plated AISI 420B	AISI 420B	AISI 304
2 - Rod seal	PU	PU	NBR	NBR	PU for -40°C/-50°C	FKM	PU
3 - End-block	Aluminium	Aluminium	Aluminium	Aluminium	Aluminium	Aluminium	Aluminium
4 - Counterbore seal	NBR	NBR	NBR	NBR	NBR for -40°C/-50°C	FKM	NBR
5 - Extruded profile	Anodized aluminium	Anodized aluminium	Anodized aluminium	Anodized aluminium	Anodized aluminium	Anodized aluminium	Anodized aluminium
6 - Piston seal	PU	PU	NBR	PU	PU for -40°C/-50°C	FKM	PU
7 - Piston	Technopolymer (ø 32) or Aluminium (ø 40 ÷ 125)	Aluminium (ø 125) or Technopolymer (ø 32 ÷ 100)	Aluminium	Aluminium	Aluminium	Aluminium	Aluminium
8 - Cushion seal	PU	PU	PU	PU	PU	FKM	PU
9 - Self-tapping screw	Zinc-plated steel	-	Zinc-plated steel	Zinc-plated steel	Zinc-plated steel	Zinc-plated steel	Zinc-plated steel
10 - Tie-rod nut	-	Zinc-plated steel	Zinc-plated steel	Zinc-plated steel	AISI 303	Zinc-plated steel	Zinc-plated steel
11 - Tie-rod	-	Zinc-plated steel	Zinc-plated steel	Zinc-plated steel	AISI 420B	Zinc-plated steel	Zinc-plated steel
12 - Rod scraper	-	-	-	Brass	Brass	-	-
13 - Rod nut	Zinc-plated steel	Zinc-plated steel	Zinc-plated steel	Zinc-plated steel	AISI 304	Zinc-plated steel	AISI 304
14 - Rod guide bush	Technopolymer	Technopolymer	Technopolymer	Technopolymer	Technopolymer	Steel + PTFE	Technopolymer

Series 63 low friction cylinders - APPLICATION EXAMPLES

SERIES 63 CYLINDERS

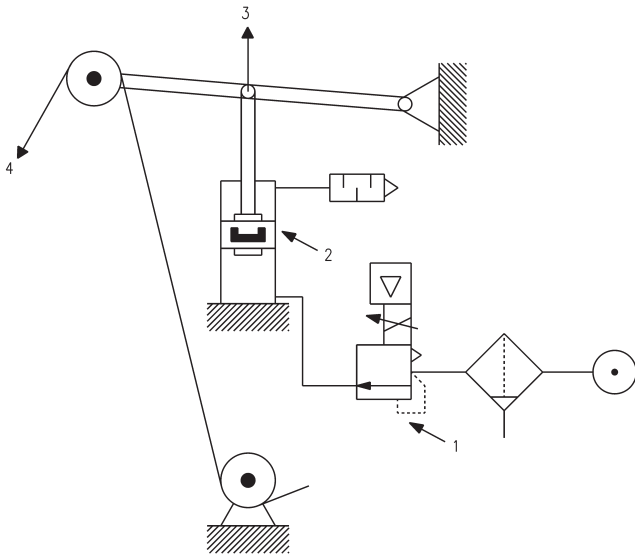

CYLINDER IN THRUST

DRAWING NOTES:

- 1. Precision pressure regulator or proportional regulator
- 2. Low friction cylinder
- 3. Force direction
- 4. Band

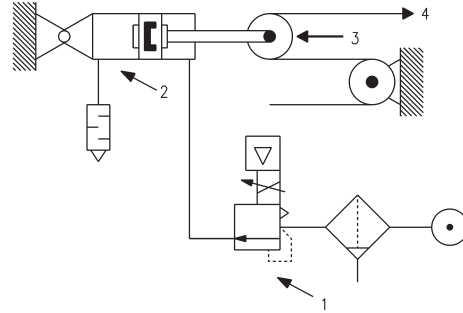

CYLINDER IN TRACTION

Note: in order to reach the highest performance, it is recommended to connect a precision pressure regulator or a proportional regulator with the low friction cylinder as shown in the drawing.

SERIES 63 CYLINDERS ACCESSORIES

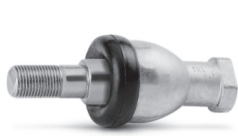

Piston rod socket joint
Mod. GY



Piston rod lock nut
Mod. U



Clevis pin Mod. S



Rear trunnion ball-joint
Mod. R



Coupling piece
Mod. GKF



Swivel ball joint Mod. GA

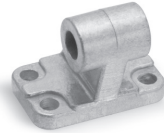

90° male trunnion
Mod. ZC



Swivel Combination
Mod. C+L+S



Front and rear flange
Mod. D-E



Self aligning rod
Mod. GK



Centre trunnion
Mod. F-63, profile cyl.



Foot mount
Mod. B-41



Front female trunnion
Mod. H and C-H



Rear female trunnion
Mod. C and C-H

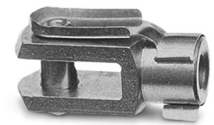

Rod fork end Mod. G



Rear trunnion male
Mod. L



Disassemble cyl. key Ø 80
and 100, round tube

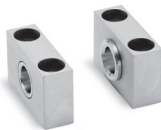

Counter bracket for centre
trunnion Mod. BF



Front/rear spot faced
trunnion Mod. FN



Opposed cylinder coupler
Mod. DC-63



Centre trunnion Mod. F,
round tube cyl.



Accessory to mount valves
on the cylinder

Special key to
disassemble cylinders Ø



All accessories are supplied separately, except for piston rod lock nut Mod. U

Series 63 cylinders - profile, double-acting

Versions: 63MP2... 63LP2... and 63VP2...

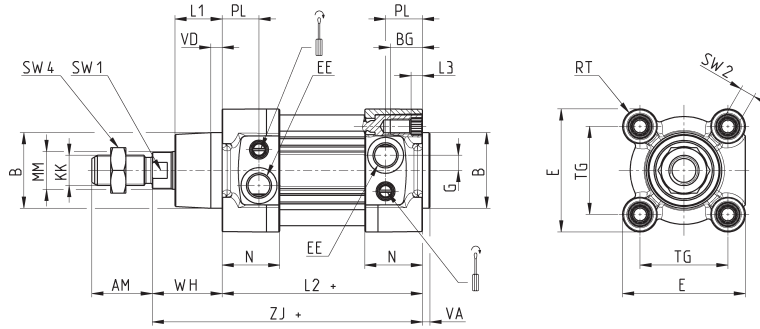

+ = add the stroke

DIMENSIONS																							
Ø	ØMM	KK	ØB	PL	L1	AM	VA	EE	WH	L2+	L3	ZJ+	VD	N	BG	RT	G	TG	E	SW1	SW2	SW4	Front/rear cushion stroke
32	12	M10x1.25	30	18.5	18	22	4	G1/8	26	94	5.5	120	5	27	16	M6	5	32.5	47	10	6	17	17
40	16	M12x1.25	35	19	21	24	4	G1/4	30	105	5.5	135	5	30	16	M6	5	38	55	13	6	19	18
50	20	M16x1.5	40	19.5	25	32	4	G1/4	37	106	6	143	6	30.5	16	M8	8	46.5	65	17	8	24	20
63	20	M16x1.5	45	24	26	32	4	G3/8	37	121	6	158	6	37.5	16	M8	8	56.5	75	17	8	24	22
80	25	M20x1.5	45	23.5	30	40	4	G3/8	46	128	0	174	7	37	19	M10	8	72	93	22	6	30	25
100	25	M20x1.5	55	24	35	40	4	G1/2	51	138	0	189	7	39.5	19.5	M10	8	89	110	22	6	30	26
125	32	M27x2	60	28	42	54	6	G1/2	65	160	6	225	8	44	23	M12	10.5	110	135	27	12	41	33

Series 63 cylinders - round tube, double-acting

Versions: 63MT2... 63LT2... and 63VT2...

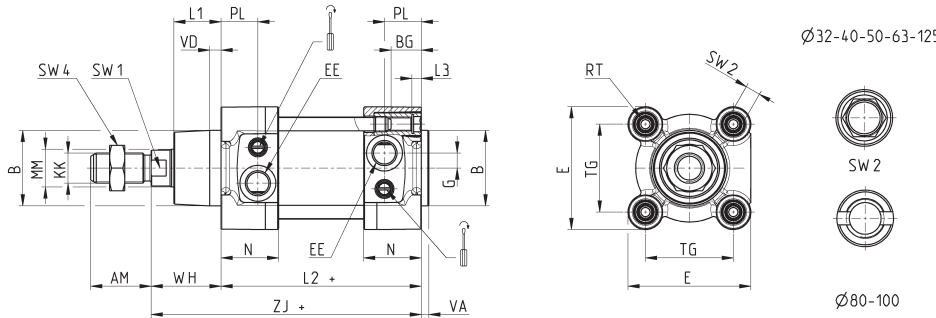

+ = add the stroke

Table note:
* = special key 80-62/8C
(see accessories)

DIMENSIONS																							
Ø	ØMM	KK	ØB	PL	L1	AM	VA	EE	WH	L2+	L3	ZJ+	VD	N	BG	RT	G	TG	E	SW1	SW2	SW4	Front/rear cushion stroke
32	12	M10x1.25	30	18.5	18	22	4	G1/8	26	94	5	120	5	27	16	M6	5	32.5	47	10	6	17	17
40	16	M12x1.25	35	19	21	24	4	G1/4	30	105	5	135	5	30	16	M6	5	38	55	13	6	19	18
50	20	M16x1.5	40	19.5	25	32	4	G1/4	37	106	5	143	6	30.5	16	M8	8	46.5	65	17	8	24	20
63	20	M16x1.5	45	24	26	32	4	G3/8	37	121	5	158	6	37.5	16	M8	8	56.5	75	17	8	24	22
80	25	M20x1.5	45	23.5	30	40	4	G3/8	46	128	0	174	7	37	19	M10	8	72	93	22	*	30	25
100	25	M20x1.5	55	24	35	40	4	G1/2	51	138	0	189	7	39.5	19.5	M10	8	89	110	22	*	30	26
125	32	M27x2	60	28	42	54	6	G1/2	65	160	6	225	8	44	23	M12	10.5	110	135	27	12	41	33

Series 63 cylinders - profile, single-acting, front spring

Versions: 63MP1...

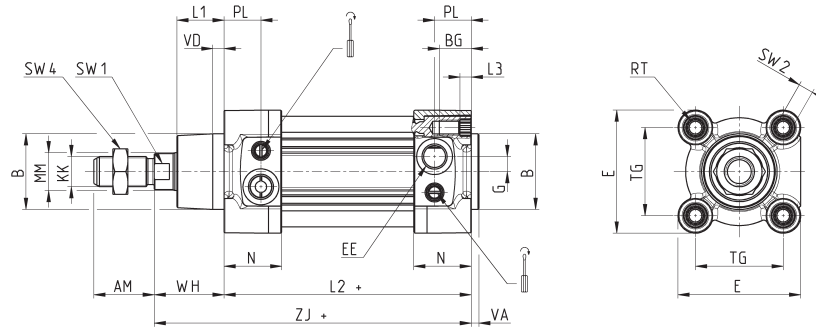

+ = add the stroke

DIMENSIONS																							
Ø	ØMM	KK	ØB	PL	L1	AM	VA	EE	WH	L2+	L3	ZJ+	VD	N	BG	RT	G	TG	E	SW1	SW2	SW4	Front/rear cushion stroke
32	12	M10x1.25	30	18.5	18	22	4	G1/8	26	119	5.5	145	5	27	16	M6	5	32.5	47	10	6	17	17
40	16	M12x1.25	35	19	21	24	4	G1/4	30	130	5.5	160	5	30	16	M6	5	38	55	13	6	19	18
50	20	M16x1.5	40	19.5	25	32	4	G1/4	37	131	6	168	6	30.5	16	M8	8	46.5	65	17	8	24	20
63	20	M16x1.5	45	24	26	32	4	G3/8	37	146	6	183	6	37.5	16	M8	8	56.5	75	17	8	24	22
80	25	M20x1.5	45	23.5	30	40	4	G3/8	46	153	0	199	7	37	19	M10	8	72	93	22	6	30	25
100	25	M20x1.5	55	24	35	40	4	G1/2	51	163	0	214	7	39.5	19.5	M10	8	89	110	22	6	30	26
125	32	M27x2	60	28	42	54	6	G1/2	65	185	6	250	8	44	23	M12	10.5	110	135	27	12	41	33

Series 63 cylinders - profile, single-acting, rear spring

Versions: 63MP9...

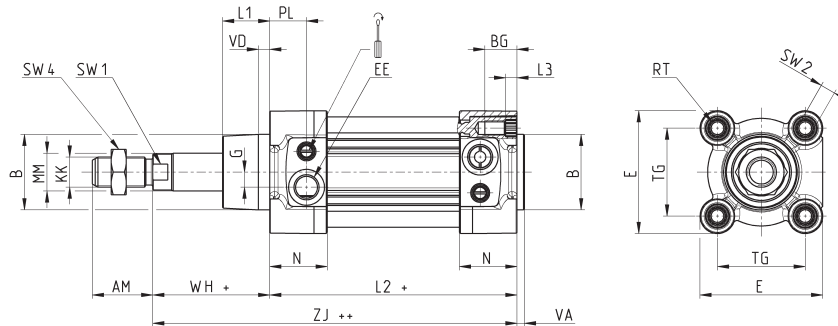

+ = add the stroke
++ = add the stroke twice

DIMENSIONS																							
Ø	ØMM	KK	ØB	PL	L1	AM	VA	EE	WH+	L2+	L3	ZJ++	VD	N	BG	RT	G	TG	E	SW1	SW2	SW4	Front/rear cushion stroke
32	12	M10x1.25	30	18.5	18	22	4	G1/8	51	119	5.5	170	5	27	16	M6	5	32.5	47	10	6	17	17
40	16	M12x1.25	35	19	21	24	4	G1/4	55	130	5.5	185	5	30	16	M6	5	38	55	13	6	19	18
50	20	M16x1.5	40	19.5	25	32	4	G1/4	62	131	6	193	6	30.5	16	M8	8	46.5	65	17	8	24	20
63	20	M16x1.5	45	24	26	32	4	G3/8	62	146	6	208	6	37.5	16	M8	8	56.5	75	17	8	24	22
80	25	M20x1.5	45	23.5	30	40	4	G3/8	71	153	0	224	0	37	19	M10	8	72	93	22	6	30	25
100	25	M20x1.5	55	24	35	40	4	G1/2	76	163	0	239	0	39.5	19.5	M10	8	89	110	22	6	30	26
125	35	M27x2	60	28	42	54	6	G1/2	90	185	6	275	6	44	23	M12	10.5	110	135	27	12	41	33

Series 63 cylinders - round tube, single-acting, front spring

Versions: 63MT1...

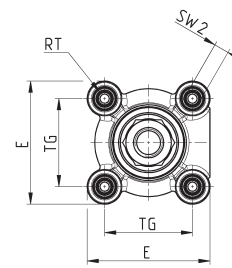
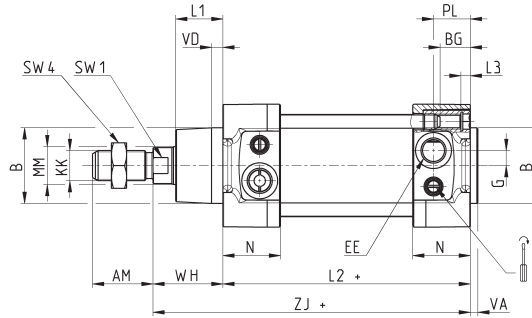

Ø32-40-50-63-125



Ø80-100

+ = add the stroke

Table note:
* = special key 80-62/8C
(see accessories)

DIMENSIONS																							
Ø	ØMM	KK	ØB	PL	L1	AM	VA	EE	WH	L2+	L3	ZJ+	VD	N	BG	RT	G	TG	E	SW1	SW2	SW4	Front/rear cushion stroke
32	12	M10x1.25	30	18.5	18	22	4	G1/8	26	119	5	145	5	27	16	M6	5	32.5	47	10	6	17	17
40	16	M12x1.25	35	19	21	24	4	G1/4	30	130	5	160	5	30	16	M6	5	38	55	13	6	19	18
50	20	M16x1.5	40	19.5	25	32	4	G1/4	37	131	5	168	6	30.5	16	M8	8	46.5	65	17	8	24	20
63	20	M16x1.5	45	24	26	32	4	G3/8	37	146	5	183	6	37.5	16	M8	8	56.5	75	17	8	24	22
80	25	M20x1.5	45	23.5	30	40	4	G3/8	46	153	0	199	7	37	19	M10	8	72	93	22	*	30	25
100	25	M20x1.5	55	24	35	40	4	G1/2	51	163	0	214	7	39.5	19.5	M10	8	89	110	22	*	30	26
125	32	M27x2	60	28	42	54	6	G1/2	65	185	6	250	8	44	23	M12	10.5	110	135	27	12	41	33

Series 63 cylinders - round tube, single-acting, rear spring

Versions: 63MT9...

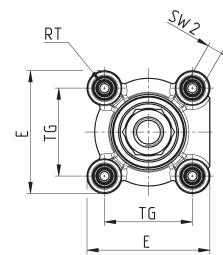
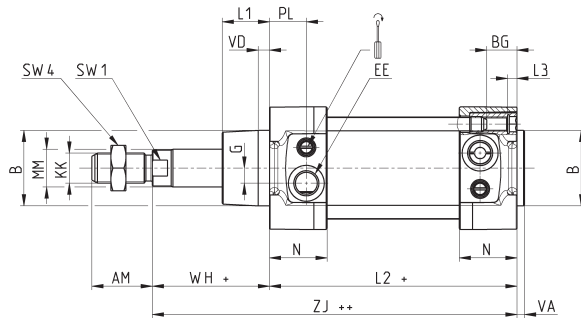

Ø32-40-50-63-125



Ø80-100

+ = add the stroke

Table note:
* = special key 80-62/8C
(see accessories)

DIMENSIONS																							
Ø	ØMM	KK	ØB	PL	L1	AM	VA	EE	WH+	L2+	L3	ZJ++	VD	N	BG	RT	G	TG	E	SW1	SW2	SW4	Front/rear cushion stroke
32	12	M10x1.25	30	18.5	18	22	4	G1/8	51	119	5	170	5	27	16	M6	5	32.5	47	10	6	17	17
40	16	M12x1.25	35	19	21	24	4	G1/4	55	130	5	185	5	30	16	M6	5	38	55	13	6	19	18
50	20	M16x1.5	40	19.5	25	32	4	G1/4	62	131	5	193	6	30.5	16	M8	8	46.5	65	17	8	24	20
63	20	M16x1.5	45	24	26	32	4	G3/8	62	146	5	208	6	37.5	16	M8	8	56.5	75	17	8	24	22
80	25	M20x1.5	45	23.5	30	40	4	G3/8	71	153	0	224	7	37	19	M10	8	72	93	22	*	30	25
100	25	M20x1.5	55	24	35	40	4	G1/2	76	163	0	239	7	39.5	19.5	M10	8	89	110	22	*	30	26
125	35	M27x2	60	28	42	54	6	G1/2	90	185	6	275	8	44	23	M12	10.5	110	135	27	12	41	33

Series 63 cylinders - profile, through rod

Versions: 63MP6..., 63MP7...

For the single-acting cylinders, the dimensions L2 and ZM have to be increased with 25 mm.

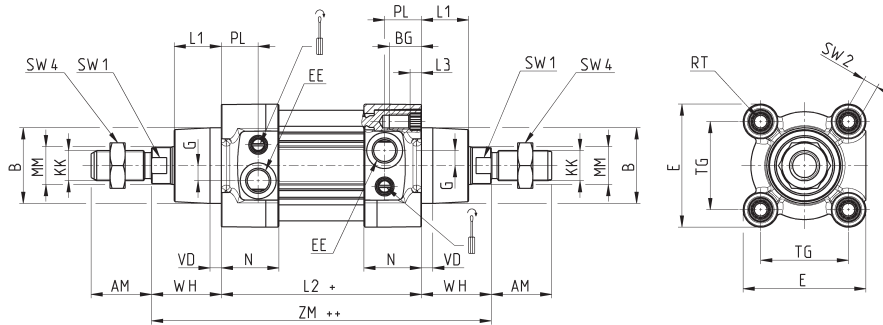

+ = add the stroke
++ = add the stroke twice

Ø	ØMM	KK	ØB	PL	L1	AM	EE	WH	L2+	L3	ZM++	VD	N	BG	RT	G	TG	E	ØF	SW1	SW2	SW4	Front/rear cushion stroke
32	12	M10x1.25	30	18.5	18	22	G1/8	26	94	5.5	146	5	27	16	M6	5	32.5	47	-	10	6	17	17
40	16	M12x1.25	35	19	21	24	G1/4	30	105	5.5	165	5	30	16	M6	5	38	55	-	13	6	19	18
50	20	M16x1.5	40	19.5	25	32	G1/4	37	106	6	180	6	30.5	16	M8	8	46.5	65	8	17	8	24	20
63	20	M16x1.5	45	24	26	32	G3/8	37	121	6	195	6	37.5	16	M8	8	56.5	75	8	17	8	24	22
80	25	M20x1.5	45	23.5	30	40	G3/8	46	128	7	220	7	37	19	M10	8	72	93	8	22	6	30	25
100	25	M20x1.5	55	24	35	40	G1/2	51	138	7	240	7	39.5	19.5	M10	8	89	110	8	22	6	30	26
125	32	M27x2	60	28	42	54	G1/2	65	160	8	290	8	44	23	M12	10.5	110	135	-	27	12	41	33

Series 63 cylinders - round tube, through rod

Versions: 63MT6..., 63MT7...

For the single-acting cylinders, the dimensions L2 and ZM have to be increased with 25 mm.

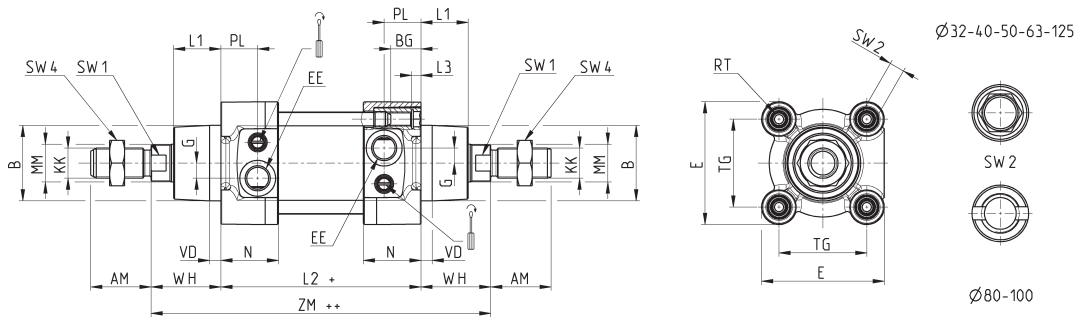

+ = add the stroke
++ = add the stroke twice

Table note:
* = special key 80-62/8C
(see accessories)

Ø	ØMM	KK	ØB	PL	L1	AM	EE	WH	L2+	L3	ZM++	VD	N	BG	RT	G	TG	E	ØF	SW1	SW2	SW4	Front/rear cushion stroke
32	12	M10x1.25	30	18.5	18	22	G1/8	26	94	5	146	5	27	16	M6	5	32.5	47	-	10	6	17	17
40	16	M10x1.25	35	19	21	24	G1/4	30	105	5	165	5	30	16	M6	5	38	55	-	13	6	19	18
50	20	M16x1.5	40	19.5	25	32	G1/4	37	106	5	180	6	30.5	16	M8	8	46.5	65	8	17	8	24	20
63	20	M16x1.5	45	24	26	32	G3/8	37	121	5	195	6	37.5	16	M8	8	56.5	75	8	17	8	24	22
80	25	M20x1.5	45	23.5	30	40	G3/8	46	128	0	220	7	37	19	M10	8	72	93	8	22	*	30	25
100	25	M20x1.5	55	24	35	40	G1/2	51	138	0	240	7	39.5	19.5	M10	8	89	110	8	22	*	30	26
125	32	M27x2	60	28	42	54	G1/2	65	160	6	290	8	44	23	M12	10.5	110	135	-	27	12	41	33

Series 63 cylinders with rod lock

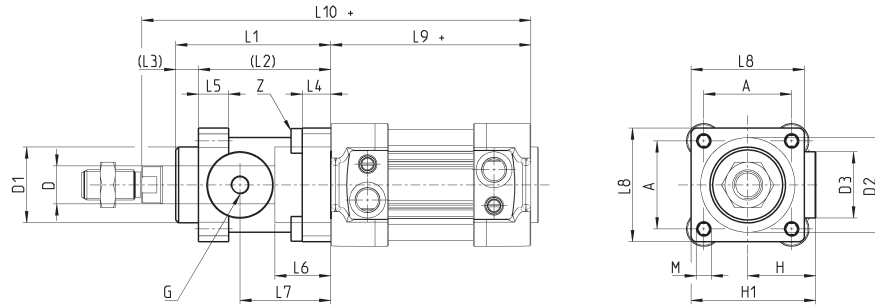

+ = add the stroke

SERIES 63 CYLINDERS

DIMENSIONS																				
Ø	øD	øD1	øD2	øD3	A	G	H	H1	L1	L2	L3	L4	L5	L6	L7	L8	L9+	L10+	M	Z
32	12	30.5	35	25	32.5	M5	25.5	46.5	58	48	10	8	13	20.5	34	45	94	160	M6	M6X20
40	16	35	40	28	38	G1/8	30	53	65	55	10	8	13	22.5	38	50	105	178	M6	M6X20
50	20	40	50	35	46.5	G1/8	36	64	82	70	12	15	16	29.5	48	60	106	200	M8	M6X20
63	20	45	60	38	56.5	G1/8	40	75	82	70	12	15	16	29.5	49.5	70	121	215	M8	M8X30
80	25	45	80	48	72	G1/8	50	95	110	90	20	18	20	35	61	90	128	254	M10	M10X35
100	25	55	100	58	89	G1/8	58	110.5	115	100	15	18	20	39	69	105	138	269	M10	M10X35
125	32	60	130	65	110	G1/8	80	150	167	122	45	22	30	51	86.5	140	160	350	M12	M12X40

Series 63 cylinders with female rod thread

New version

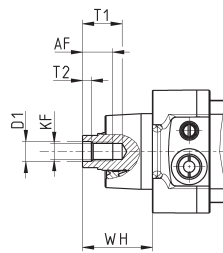

Ø	AF Min	KF	D1 Ø	T1 Max	T2	WH
32	12	M6X1	6.4	16	2.6	26
40	12	M8X1.25	8.4	16	3.3	30
50	16	M10X1.5	10.5	21	4.7	37
63	16	M10X1.5	10.5	21	4.7	37
80	20	M12X1.75	13	26.5	6.1	46
100	20	M12X1.75	13	26.5	6.1	54
125	32	M16X2	17	40	8	65

Series 63 cylinders - round tube, tandem version

New version

+ = add the stroke
++ = add the stroke twice

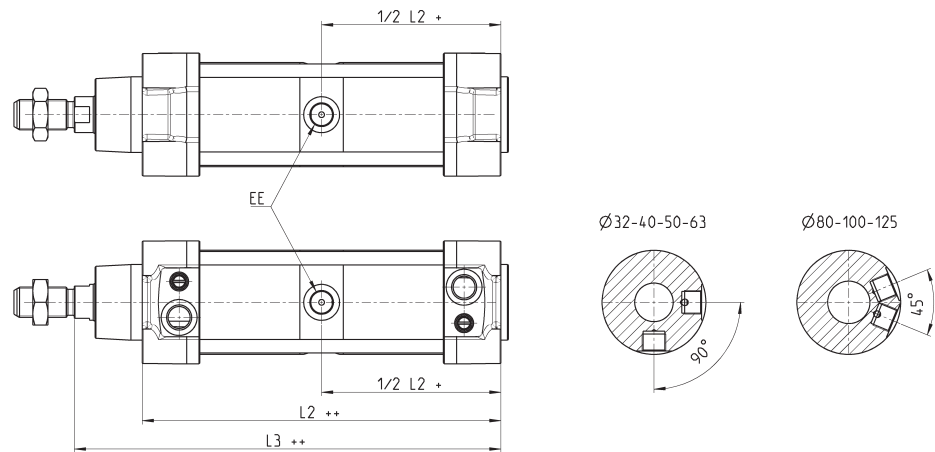

Ø	EE	L2 ++	L3 ++
32	G1/8	171.5	197.5
40	G1/4	191.5	221.5
50	G1/4	188	225
63	G3/8	204	241
80	G3/8	225.5	271.5
100	G1/2	231	282
125	G1/2	264	329

Series 63 cylinders - profile, tandem version

New version

+ = add the stroke
++ = add the stroke twice

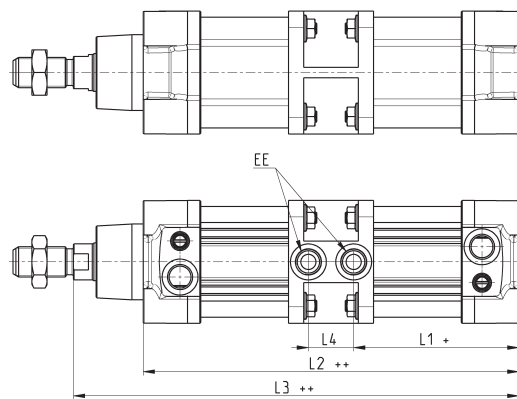

Ø	EE	L1+	L2++	L3++	L4
32	G1/8	76.5	171.5	197.5	18.5
40	G1/4	88.5	200	230	23
50	G1/4	87.5	199	236	24
63	G3/8	98	223	260	27
80	G3/8	104.5	236	282	27
100	G1/2	116	260	311	28
125	G1/2	132	264	329	0

Series 63 cylinders - round tube, multi-position version

New version

X1 = partial stroke
X2 = total stroke

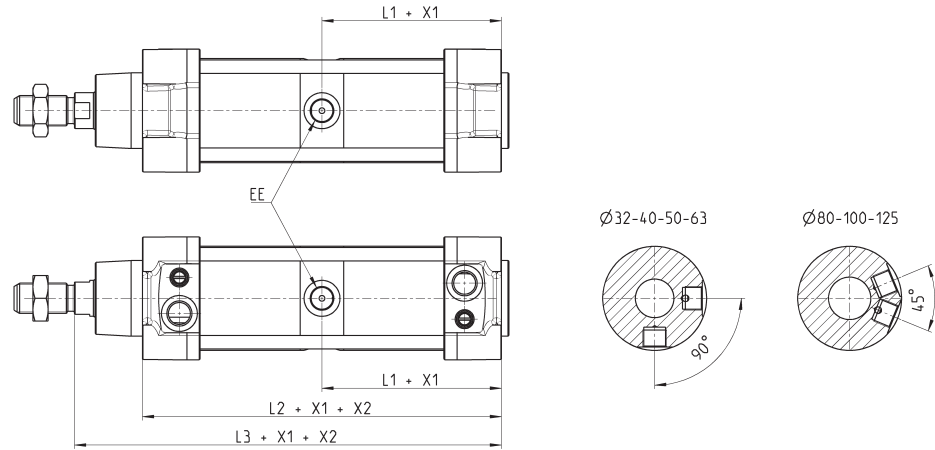

Ø	EE	L1	L2	L3
32	G1/8	86	171.5	197.5
40	G1/4	96	191.5	221.5
50	G1/4	94	188	225
63	G3/8	102	204	241
80	G3/8	113	225.5	271.5
100	G1/2	115.5	231	282
125	G1/2	132	264	329

Series 63 cylinders - profile, multi-position version

New version

X1 = partial stroke
X2 = total stroke

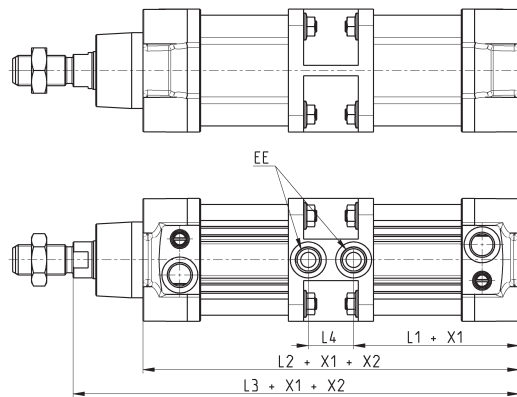

Ø	EE	L1+	L2++	L3++	L4
32	G1/8	76.5	171.5	197.5	18.5
40	G1/4	88.5	200	230	23
50	G1/4	87.5	199	236	24
63	G3/8	98	223	260	27
80	G3/8	104.5	236	282	27
100	G1/2	116	260	311	28
125	G1/2	132	264	329	0

Series 63 cylinders with protective bellow

New version

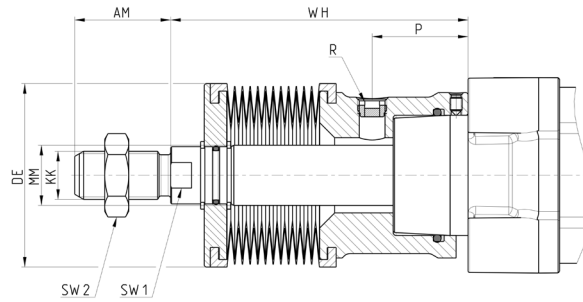

∅	Stroke	WH	AM	KK	MM	P	R	DE	SW1	SW2
32	0 ÷ 245	88	22	M10X1.25	12	25	G1/8	61	10	17
32	246 ÷ 490	132	22	M10X1.25	12	25	G1/8	61	10	17
40	0 ÷ 245	89	24	M12X1.25	16	26	G1/8	61	13	19
40	246 ÷ 490	133	24	M12X1.25	16	26	G1/8	61	13	19
50	0 ÷ 245	99	32	M16X1.5	20	30	G1/8	61	17	24
50	246 ÷ 490	143	32	M16X1.5	20	30	G1/8	61	17	24
63	0 ÷ 245	76	32	M16X1.5	20	16.5	G1/8	61	17	24
63	246 ÷ 490	120	32	M16X1.5	20	16.5	G1/8	61	17	24
80	0 ÷ 285	86	40	M20X1.5	25	11.5	G1/8	83	22	30
80	286 ÷ 570	139	40	M20X1.5	25	11.5	G1/8	83	22	30
100	0 ÷ 285	86	40	M20X1.5	25	12	G1/8	83	22	30
100	286 ÷ 570	139	40	M20X1.5	25	12	G1/8	83	22	30
125	0 ÷ 285	108	54	M27X2	32	30	G1/8	83	29	41
125	286 ÷ 570	161	54	M27X2	32	30	G1/8	83	29	41

Series 63 cylinders - round tube, back to back (TR)

New version

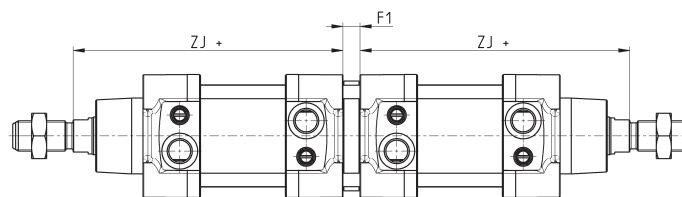

∅	F1	ZJ+	max overall stroke (mm)
32	9	120	500
40	9	135	800
50	9	143	800
63	9	158	700
80	9	174	1000
100	9	189	900
125	20	225	1000

Opposed cylinder coupler Mod. DC-63



Material: Aluminium

Supplied with:
1x flange
8x locking screws
8x nuts

+ = add the stroke

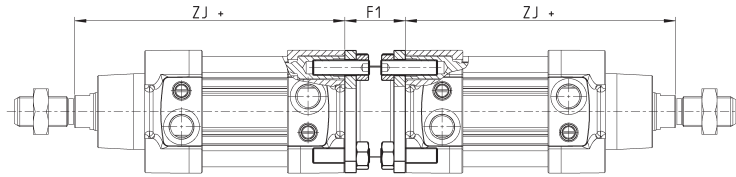

DIMENSIONS						
Mod.	∅	F1	ZJ+	weight (g)	max overall stroke (mm)	torque force
DC-63-32	32	27	120	130	500	5 Nm
DC-63-40	40	27	135	160	800	5 Nm
DC-63-50	50	32	143	285	800	10 Nm
DC-63-63	63	28	158	340	700	10 Nm
DC-63-80	80	38	174	670	1000	15 Nm
DC-63-100	100	38	189	820	900	15 Nm
DC-63-125	125	48	225	1300	1000	20 Nm

Foot mount Mod. B-41



Material: zinc-plated steel

Supplied with:
2x feet
4x screws

+ = add the stroke

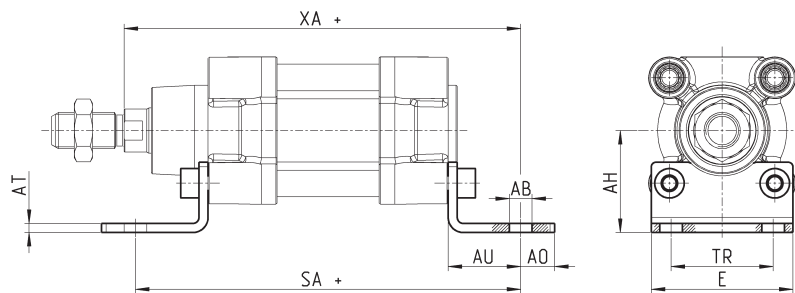

DIMENSIONS											
Mod.	∅	AT	SA+	XA+	TR	E	AB	AH	AO	AU	torque force
B-41-32	32	4	142	144	32	45	7	32	11	24	5 Nm
B-41-40	40	4	161	163	36	53,5	10	36	15	28	5 Nm
B-41-50	50	4	170	175	45	62,5	10	45	15	32	10 Nm
B-41-63	63	5	185	190	50	73	10	50	15	32	10 Nm
B-41-80	80	6	210	216	63	92	12	63	20	41	15 Nm
B-41-100	100	6	220	230	75	108,5	14,5	71	25	41	15 Nm
B-41-125	125	7	250	270	90	132	16,5	90	25	45	20 Nm

Front and rear flange Mod. D-E

Material: Aluminium



Supplied with:
1x flange
4x screws
+ = add the stroke

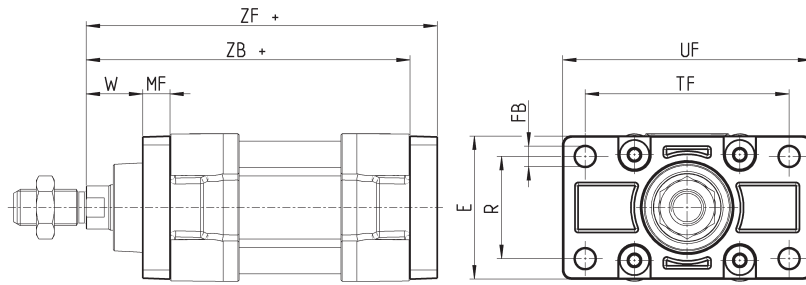

Mod.	∅	W	MF	ZB	TF	R	UF	E	FB	ZF	torque force
D-E-41-32	32	16	10	120	64	32	80	45	7	130	5 Nm
D-E-41-40	40	20	10	135	72	36	90	52	9	145	5 Nm
D-E-41-50	50	25	12	143	90	45	110	65	9	155	10 Nm
D-E-41-63	63	25	12	158	100	50	120	75	9	170	10 Nm
D-E-41-80	80	30	16	174	126	63	148	95	12	190	15 Nm
D-E-41-100	100	35	16	189	150	75	176	115	14	205	15 Nm
D-E-41-125	125	45	20	225	180	90	220	140	16	245	20 Nm

Rear female trunnion Mod. C and C-H

Material: Aluminium



Supplied with:
1x female trunnion
4x screws
+ = add the stroke

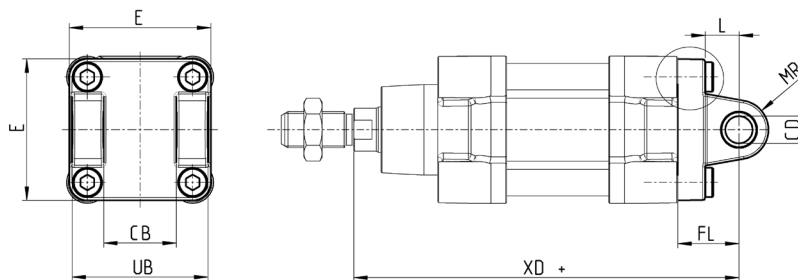

∅32



Mod.	∅	CD	L	FL	XD	MR	E	CB	UB	torque force
C-41-32	32	10	12.5	22	142	10	47	26	46.5	5 Nm
C-41-40	40	12	16	25	160	12	52	28	52	5 Nm
C-41-50	50	12	16	27	170	12	64	32	60	10 Nm
C-H-41-63	63	16	21	32	190	16	74	40	70	10 Nm
C-H-41-80	80	16	22	36	210	16	93	50	90	15 Nm
C-H-41-100	100	20	27	41	230	20	114	60	110	15 Nm
C-H-41-125	125	25	30	50	275	25	140	70	130	20 Nm

Front female trunnion Mod. H and C-H

Material: Aluminium

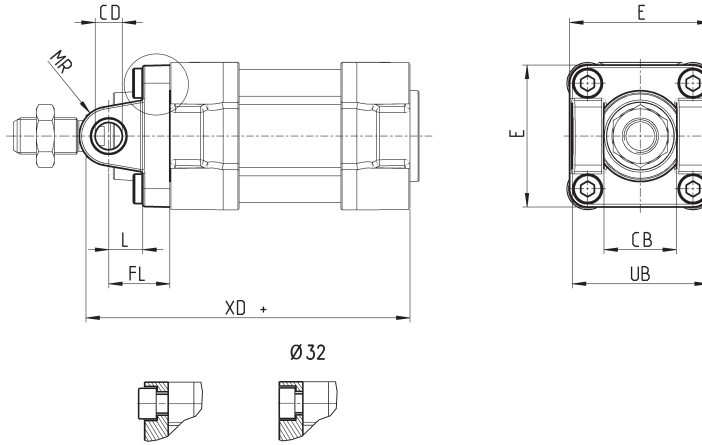

Supplied with:
1x female trunnion
4x screws

+ = add the stroke

SERIES 63 CYLINDERS

Mod.	Ø	CB	UB	E	XD+	FL	L	CD	MR	torque force
H-41-32	32	26	46.5	47	120	22	12.5	10	10	5 Nm
H-41-40	40	28	52	52	135	25	16	12	12	5 Nm
H-41-50	50	32	60	64	143	27	16	12	12	10 Nm
H-60-63	63	40	70	74	158	32	21	16	16	10 Nm
C-H-41-80	80	50	90	94	174	36	22	16	16	15 Nm
C-H-41-100	100	60	110	114	189	41	27	20	20	15 Nm
C-H-41-125	125	70	130	140	225	50	30	25	25	20 Nm

Rear male trunnion Mod. L

Material: Aluminium

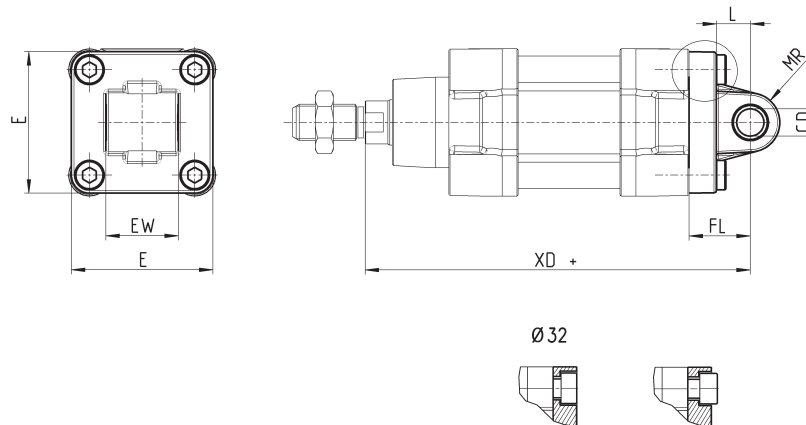

Supplied with:
1x male trunnion
4x screws

+ = add the stroke

DIMENSIONS										
Mod.	Ø	CD	L	FL	XD	MR	E	EW	torque force	
L-41-32	32	10	12.5	22	142	10	47	26	5 Nm	
L-41-40	40	12	16	25	160	12	52	28	5 Nm	
L-41-50	50	12	16	27	170	12	64	32	10 Nm	
L-41-63	63	16	21	32	190	15.5	74	40	10 Nm	
L-41-80	80	16	22	36	210	16	94	50	15 Nm	
L-41-100	100	20	27	41	230	20	114	60	15 Nm	
L-41-125	125	25	30	50	275	25	140	70	20 Nm	

Front/rear spot faced trunnion Mod. FN

Material: zinc-plated steel

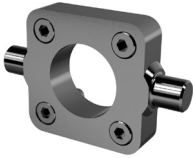

Supplied with:
1x centre spot faced trunnion
4x screws

+ = add the stroke

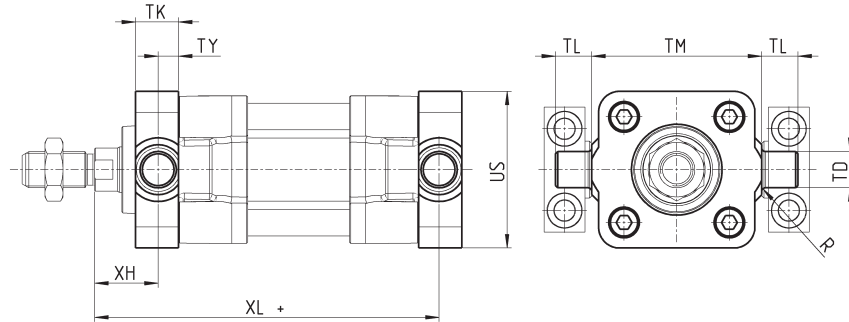

DIMENSIONS											
Mod.	∅	TK	TY	XH	XL+	US	TL	TM	TD	R	torque force
FN-32	32	14	6.5	19.5	126.5	46	12	50	12	1	5 Nm
FN-40	40	19	9	21	144	59	16	63	16	1.5	5 Nm
FN-50	50	19	9	28	152	69	16	75	16	1.6	10 Nm
FN-63	63	24	11.5	25.5	169.5	84	20	90	20	1.6	10 Nm
FN-80	80	24	11.5	34.5	185.5	102	20	110	20	1.6	15 Nm
FN-100	100	29	14	37	203	125	25	132	25	2	15 Nm
FN-125	125	30	15	50	240	150	25	160	25	2	20 Nm

Trunnion ball-joint Mod. R

* This trunnion doesn't comply with the ISO 15552 standard
Material: Aluminium



Supplied with:
1x trunnion ball joint
4x screws

+ = add the stroke

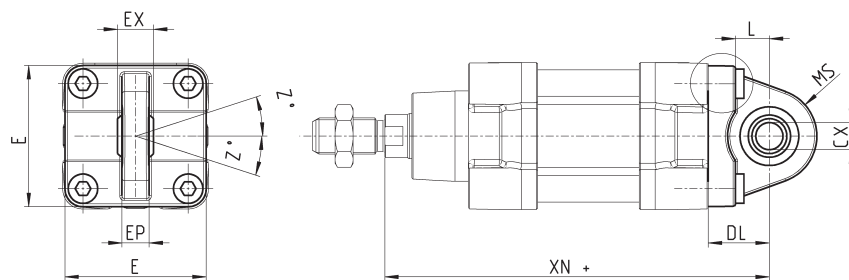

R-41-50/80/125

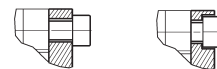

Mod.	∅	∅CX	L	DL+	XN+	MS	E	EX	EP	Z	torque force
R-41-32	32	10	13	22	142	16	45	14	10.5	4	5 Nm
R-41-40	40	12	16	25	160	19	52	16	12	4	5 Nm
R-41-50*	50	12	15	27	170	21	62.5	16	12	4	10 Nm
R-50	50	16	16	27	170	21,5	65	21	15	4	10 Nm
R-41-63	63	16	21	32	190	24	75	21	15	4	10 Nm
R-41-80*	80	16	24	36	210	28	92	21	15	4	15 Nm
R-80	80	20	22	36	210	28,5	95	25	18	4	15 Nm
R-41-100	100	20	27	41	230	30	115	25	18	4	15 Nm
R-41-125	125	30	30	50	275	40	140	37	25	4	20 Nm

Centre trunnion Mod. F for round tube cylinders



Material: zinc-plated steel

Supplied with:
1x intermediate trunnion
8x locking screws

+ = add the stroke

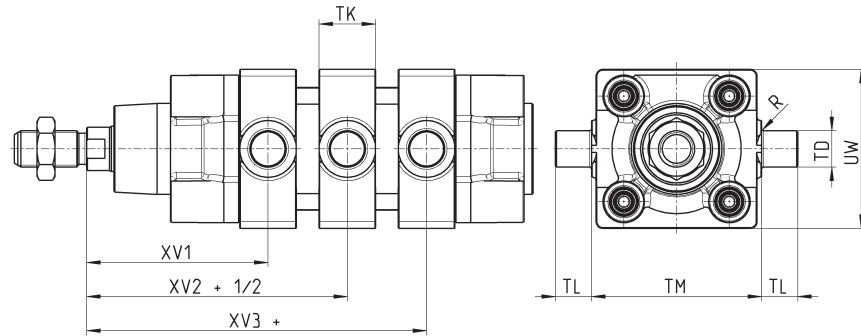

DIMENSIONS										
Mod.	∅	XV1	XV2+	XV3+	TM	TK	TD	TL	UW	R
F-32	32	63	73	83	50	20	12	12	62	0.5
F-40	40	70	82.5	95	61	20	16	16	70	1
F-50	50	80	90	100	71	25	16	16	91	1
F-63	63	87	97.5	108	84	25	20	20	90	1
F-80	80	98	110	122	106	30	20	20	115	1
F-100	100	105.5	120	134.5	128	30	25	25	135	1.5
F-125	125	124	145	166	156	30	25	25	162	1.5

Centre trunnion Mod. F for profile cylinders



Material: zinc-plated steel

Supplied with:
1x centre trunnion
8x locking screws
2x fixing screws

+ = add the stroke

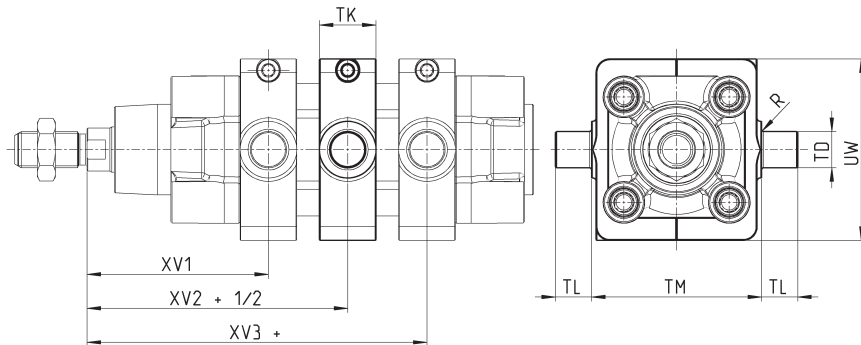

DIMENSIONS										
Mod.	∅	XV1	XV2+	XV3+	TM	TK	TD	TL	UW	R
F-63-32	32	63	73	83	50	20	12	12	62	0.5
F-63-40	40	70	82.5	95	61	20	16	16	70	1
F-63-50	50	80	90	100	71	25	16	16	91	1
F-63-63	63	87	97.5	108	84	25	20	20	90	1
F-63-80	80	98	110	122	106	30	20	20	115	1
F-63-100	100	105.5	120	134.5	128	30	25	25	135	1.5
F-63-125	125	124	145	166	156	30	25	25	162	1.5

Accessory combination Mod. C+L+S

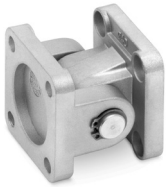

Material: Aluminium

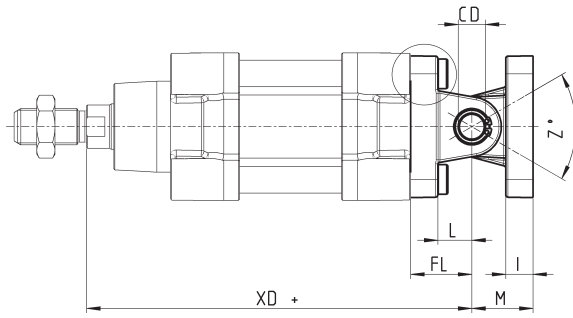
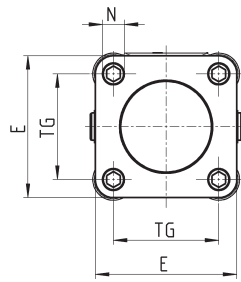

+ = add the stroke

Ø 32



DIMENSIONS												
Mod.	Ø	E	TG	_g N	XD+	_g CD	L	FL	I	M	Z° (max)	torque force
C+L+S	32	47	32.5	6.5	142	10	12.5	22	9.5	22	30	5 Nm
C+L+S	40	52	38	6.5	160	12	16	25	9	25	40	5 Nm
C+L+S	50	64	46.5	9	170	12	16	27	11	27	25	10 Nm
C+L+S	63	74	56.5	9	190	16	21	32	11	32	36	10 Nm
C+L+S	80	94	72	11	210	16	22	36	14	36	34	15 Nm
C+L+S	100	114	89	11	230	20	27	41	14	41	38	15 Nm
C+L+S	125	140	110	13	275	25	30	50	20	50	30	20 Nm

90° male trunnion Mod. ZC

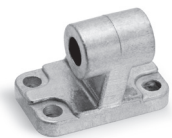

CETOP RP 107P
Material: Aluminium

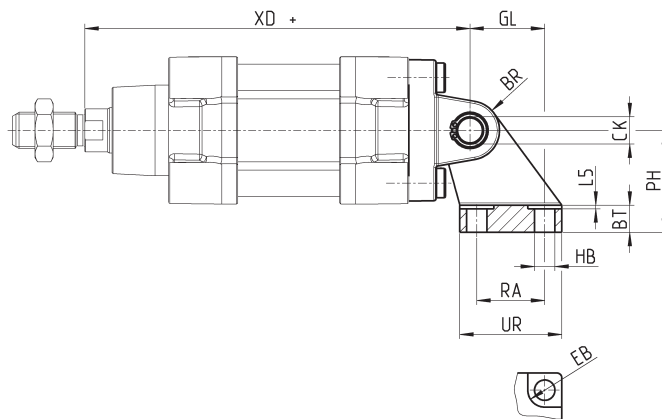
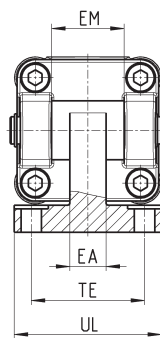

Supplied with:
1x male support

+ = add the stroke

DIMENSIONS																
Mod.	Ø	EB	CK	HB	XD+	TE	UL	EA	GL	L5	RA	EM	UR	PH	BT	BR
ZC-32	32	11	10	6,6	142	38	51	10	21	1,6	18	26	31	32	8	10
ZC-40	40	11	12	6,6	160	41	54	15	24	1,6	22	28	35	36	10	11
ZC-50	50	15	12	9	170	50	65	16	33	1,6	30	32	45	45	12	13
ZC-63	63	15	16	9	190	52	67	16	37	1,6	35	40	50	50	14	15
ZC-80	80	18	16	11	210	66	86	20	47	2,5	40	50	60	63	14	15
ZC-100	100	18	20	11	230	76	96	20	55	2,5	50	60	70	71	17	19
ZC-125	125	20	25	14	275	94	124	30	70	3,2	60	70	90	90	20	22,5

Counter bracket for centre trunnion Mod. BF

Material: Aluminium

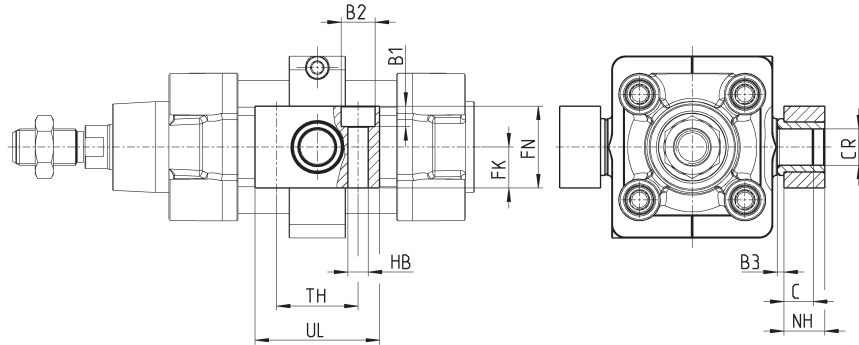
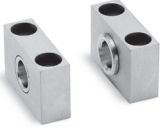

Supplied with:
2x supports

SERIES 63 CYLINDERS

Mod.	∅	∅CR	NH	C	B3	TH	UL	FK	FN	B1	B2	HB
BF-32	32	12	15	7,5	3	32	46	15	30	6,8	11	6,6
BF-40-50	40 - 50	16	18	9	3	36	55	18	36	9	15	9
BF-63-80	63 - 80	20	20	10	3	42	65	20	40	11	18	11
BF-100-125	100 - 125	25	25	12,5	3,5	50	75	25	50	13	20	14

Accessory to mount valves on the cylinder

The mounting sub-base Mod. PCV enables the valve or solenoid valve to be mounted directly on the cylinder, thus forming a compact unit to apply.

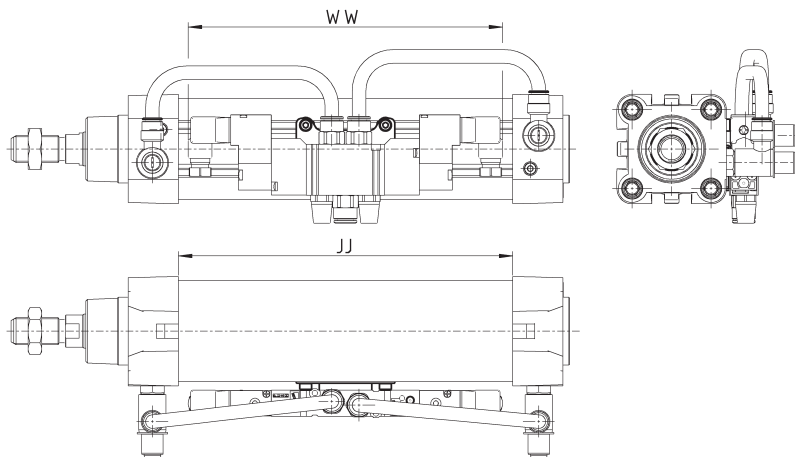
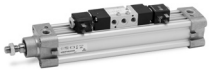

Make sure that the WW dimension of the valve to be mounted is smaller than the JJ cylinder dimension. Further information on <http://catalogue.camozzi.com/downloads>.

Mod.	
PCV-62-K3	to connect valves - solenoid valves Series 3
PCV-62-K4	to connect valves - solenoid valves Series 4 port G1/4
PCV-62-KEN	to connect valves - solenoid valves Series EN
PCV-62-K8	to connect valves - solenoid valves Series 4 port G1/8 and Series 3 port G1/4

Clevis pin Mod. S



Supplied with:
1x centering pin in stainless steel 303
2x seeger in steel

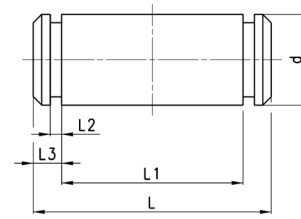

DIMENSIONS						
Mod.	∅	d	L	L1	L2	L3
S-32	32	10	52	46	1.1	3
S-40	40	12	59	53	1.1	3
S-50	50	12	67	61	1.1	3
S-63	63	16	77	71	1.1	3
S-80	80	16	97	91	1.1	3
S-100	100	20	121	111	1.3	5
S-125	125	25	140.5	132	1.3	4.25

Swivel ball joint Mod. GA



ISO 8139.
Material: zinc-plated steel.

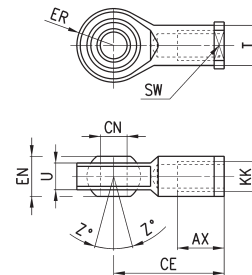

Mod.	∅ ⁽¹⁷⁾	U	EN	ER	AX	CE	KK	∅ ^T	Z	SW
GA-32	10	10,5	14	14	20	43	M10X1,25	15	6,5	17
GA-40	12	12	16	16	22	50	M12X1,25	17,5	6,5	19
GA-50-63	16	15	21	21	28	64	M16X1,5	22	7,5	22
GA-80-100	20	18	25	25	33	77	M20x1,5	27,5	7	30
GA-41-125	30	25	37	37	51	110	M27x2	40	7,5	41

Piston rod socket joint Mod. GY



Material: zama and zinc-plated steel.

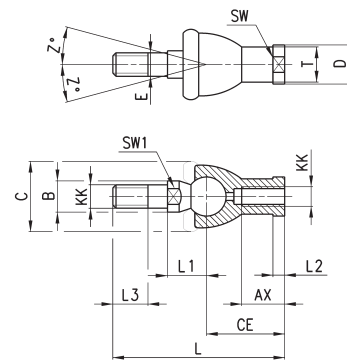

DIMENSIONS																
Mod.	∅	KK	L	CE	L2	AX	SW	SW1	L1	L3	∅ ^T	∅ ^D	E	∅ ^B	∅ ^C	Z
GY-32	32	M10X1,25	74	35	6,5	18	17	11	19,5	15	15	19	10	14	28	15
GY-40	40	M12X1,25	84	40	6,5	20	19	17	21	17	17,5	22	12	19	32	15
GY-50-63	50-63	M16X1,5	112	50	8	27	22	19	27,5	23	22	27	16	22	40	11
GY-80-100	80-100	M20x1,5	133	63	10	38	30	24	31,5	25	27,5	34	20	27	45	7,5

Rod fork end Mod. G

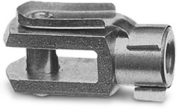

ISO 8140
Material: zinc-plated steel

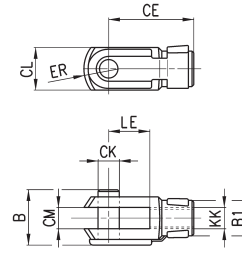

Mod.	øCK	LE	CM	CL	ER	CE	KK	B	øB1
G-25-32	10	20	10	20	12	40	M10 X 1,25	26	18
G-40	12	24	12	24	14	48	M12 X 1,25	32	20
G-50-63	16	32	16	32	19	64	M16 X 1,5	40	26
G-80-100	20	40	20	40	25	80	M20 X 1,5	48	34
G-41-125	30	54	30	55	38	110	M27 X 2	74	48

Piston rod lock nut Mod. U



ISO 4035
Material: zinc-plated steel.

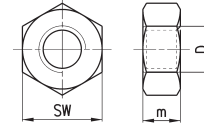

Mod.	D	m	SW
U-25-32	M10x1,25	6	17
U-40	M12x1,25	7	19
U-50-63	M16x1,5	8	24
U-80-100	M20x1,5	9	30
U-41-125	M27x2	12	41

Self aligning rod Mod. GK



Material: zinc-plated steel.

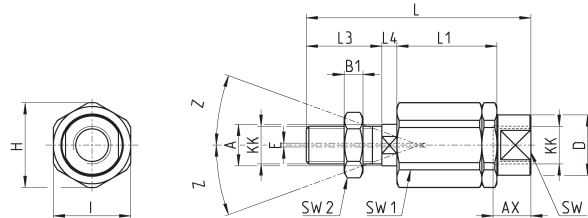

DIMENSIONS																	
Mod.	ø	KK	L	L1	L3	L4	øA	øD	H	I	SW	SW1	SW2	B1	AX	Z	E
GK-25-32	25-32	M10x1,25	71,5	35	20	7,5	14	22	32	30	19	12	17	5	22	4	2
GK-40	40	M12x1,25	75,5	35	24	7,5	14	22	32	30	19	12	19	6	22	4	2
GK-50-63	50-63	M16x1,5	104	53	32	10	22	32	45	41	27	20	24	8	30	3	2
GK-80-100	80-100	M20x1,5	119	53	40	10	22	32	45	41	27	20	30	10	37	3	2
GK-125	125	M27x2	147	60	54	10	32	57	70	65	54	24	41	12	48	4	2

Coupling piece Mod. GKF

Material: zinc-plated steel.

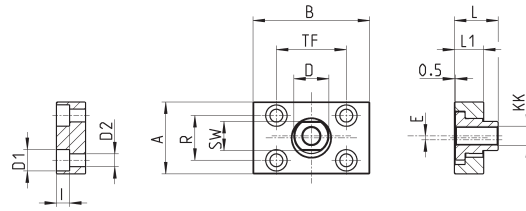

DIMENSIONS														
Mod.	∅	KK	A	B	R	TF	L	L1	I	∅ D	∅ D1	∅ D2	SW	E
GKF-25-32	32	M10x1,25	37	60	23	36	22,5	15	6,8	18	11	6,6	15	2
GKF-40	40	M12x1,25	56	60	38	42	22,5	15	9	20	15	9	15	2,5
GKF-50-63	50-63	M16x1,5	80	80	58	58	26,5	15	10,5	25	18	11	22	2,5
GKF-80-100	80-100	M20x1,5	90	90	65	65	32,5	20	13	30,5	20	14	27	2,5
GKF-125	125	M27x2	90	90	65	65	35,5	20	13	40	20	14	36	4

Special key to disassemble cylinders ∅ 80-100, round tube

Material: hardened steel

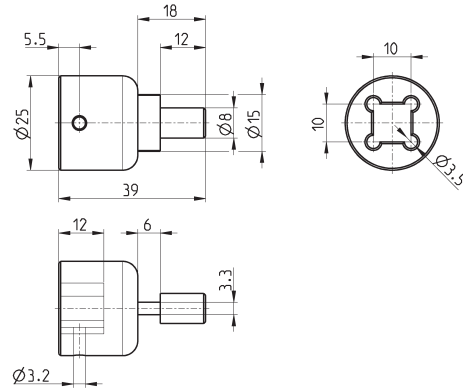

Mod.
80-62/8C