

Rodless cylinders Series 52

Double-acting, magnetic, cushioned
Ø 25, 32, 40, 50, 63 mm

SERIES 52 CYLINDERS

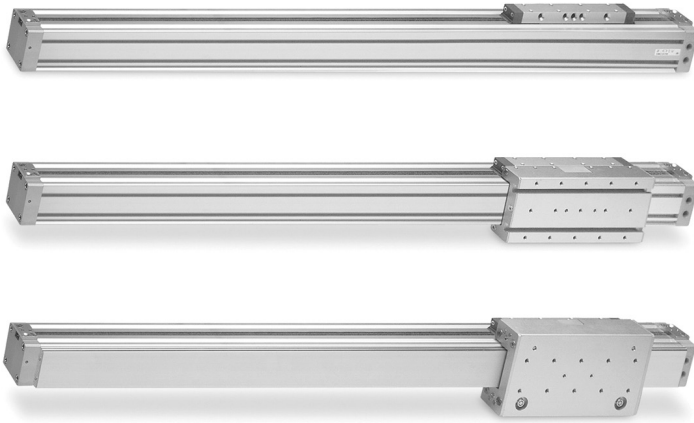

- » Three main versions, Basic, Slide bearing and Roller bearing
- » Extra short carriage as option for all versions
- » Possibility of feeding both chambers from one side only

Series 52 rodless cylinders are available in 5 diameters (25, 32, 40, 50 and 63 mm) and comes in three main versions: Basic (M), with Slide bearing (G) and with Roller bearings (R). Furthermore these three main versions are each available with either standard- or short carriage to cover a wider range of applications.

A permanent magnet is assembled on the piston allowing the position to be detected by means of proximity switches positioned in grooves located on 3 sides on the cylinder profile. The cylinder is equipped with an end stroke cushioning which can be regulated by means of a screw located on each end cover of the cylinder. These cylinders are also available in versions with air supply from one side (end cover) only if needed.

GENERAL DATA

Models	Standard, with slide bearings, with roller bearings, air supply from one or both sides, with standard or short carriage. For sizes 50 - 63 roller bearings version is not available.
Materials	AL (anodized), plastic, hardened steel, seals: NBR, PU
Operating temperature	-10°C ÷ +70°C
Operating pressure	1 ÷ 8 bar 1,5 ÷ 8 bar (Ø 25 for "R" version)
Speed	10 ÷ 1000 mm/sec (without load)
Fluid	filtered air, without lubrication. If lubricated air is used, it is recommended to use ISO VG32 oil. Once applied the lubrication should never be interrupted. If speeds exceed 1 m/s lubricated air is recommended.
Bore size	Ø 25 Ø 32 Ø 40 Ø 50 Ø 63
Cushioning length (mm)	14 mm - Ø 25 20 mm - Ø 32 25 mm - Ø 40 22 mm - Ø 50 32 mm - Ø 63
Strokes with standard carriage (version "P")	max 6000 mm - Ø25 max 5950 mm - Ø32 max 5900 mm - Ø40, Ø50 max 5880 mm - Ø63
Strokes with short carriage (version "C")	max 6000 mm
Stroke tolerance	strokes ≤ 1000 mm = 0 / +0,6 mm strokes > 1000 mm = 0 / +3 mm
Connection	G1/8 (Ø 25; 32) G1/4 (Ø 40) G3/8 (Ø 50; 63)

CODING EXAMPLE

52	M	2	P	40	A	0500
-----------	----------	----------	----------	-----------	----------	-------------

52	SERIES
M	VERSION M = standard G = with slide bearing R = with roller bearing (only Ø25 - 32 - 40)
2	OPERATION 2 = double-acting, cushioned, with air supply from both sides 8 = double-acting, cushioned, with air supply from one side only
P	MATERIALS P = anodized AL profile tube, NBR and PU seals, standard carriage C = anodized AL profile, NBR and PU seals, short carriage
40	BORE 25 = 25 mm 32 = 32 mm 40 = 40 mm 50 = 50 mm 63 = 63 mm
A	TYPE OF MOUNTING A = standard
0500	STROKE (see table)

LOADS AND TORQUE FORCES Ø 25 - 32

COMPLEX LOADS

If more than one force and torque is applied simultaneously, they have to be calculated according to the following formula: $L/L(\max) + Ls/Ls(\max) + M/M(\max) + Ms/Ms(\max) + Mv/Mv(\max) \leq 1$. For models 52M, the load and torque values refer to the center of the tube. For models 52G/52R the load and torque values refer to the center point of the external guide. It is also necessary for these models to guarantee on the fixing surface a max 0.1 flatness's value. The load and torque values refer to a velocity of: Models 52M/52G/52M/52G $\leq 0,2$ m/s, models 52R ≤ 2 m/s. Load adjustment coefficients can be found on the following page.

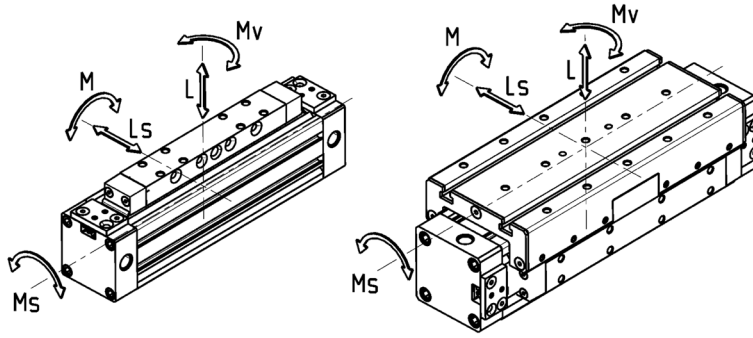

V	0.2 m/s	0.3 m/s	0.4 m/s	0.5 m/s	0.75 m/s	1 m/s
C	1	0.75	0.5	0.4	0.27	0.2

Table showing the maximum permitted loads and torque forces

Mod.	L Max (N)	Ls Max (N)	M Max (Nm)	Ms Max (Nm)	Mv Max (Nm)	Mass at 0 mm stroke (kg)	Additional mass per 100 mm (kg)
52M2P25A - 52M8P25A	270	-	13	2,5	11	0,88	0,30
52M2C25A - 52M8C25A	270	-	8	2	7	0,62	0,30
52G2P25A - 52G8P25A	580	580	23	10	23	1,31	0,30
52G2C25A - 52G8C25A	340	340	9	5	9	0,88	0,30
52R2P25A - 52R8P25A	850	1300	65	35	105	1,97	0,42
52R2C25A - 52R8C25A	850	1300	29	35	64	1,33	0,42
52M2P32A - 52M8P32A	300	-	30	3	24	1,40	0,39
52M2C32A - 52M8C32A	300	-	15	3	12	0,96	0,39
52G2P32A - 52G8P32A	850	850	33	15	33	2,09	0,39
52G2C32A - 52G8C32A	460	460	14	6,5	14	1,35	0,39
52R2P32A - 52R8P32A	900	1500	79	40	125	2,96	0,48
52R2C32A - 52R8C32A	900	1500	36	40	76	1,91	0,48

LOADS AND TORQUE FORCES Ø 40 - 50 - 63

COMPLEX LOADS

If more than one force and torque is applied simultaneously, they have to be calculated according to the following formula: $L/L(\max) + Ls/Ls(\max) + M/M(\max) + Ms/Ms(\max) + Mv/Mv(\max) \leq 1$. For models 52M, the load and torque values refer to the center of the tube. For models 52G/52R the load and torque values refer to the center point of the guide. The load and torque values refer to a velocity of: Models 52M/52G $\leq 0,2$ m/s Models 52R ≤ 2 m/s If the velocity exceeds 0.2m/s for the models 52M/52G, the load and torque values have to be multiplied by the coefficients according to the table. Load adjustment coefficients can be found on the following page.

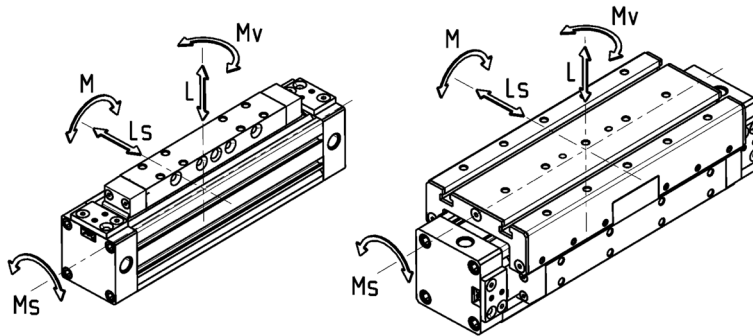

V	0.2 m/s	0.3 m/s	0.4 m/s	0.5 m/s	0.75 m/s	1 m/s
C	1	0.75	0.5	0.4	0.27	0.2

Table showing the maximum permitted loads and torque forces

Mod.	L Max (N)	Ls Max (N)	M Max (Nm)	Ms Max (Nm)	Mv Max (Nm)	Mass at 0 mm stroke (kg)	Additional mass per 100 mm (kg)
52M2P40A - 52M8P40A	650	-	60	4	54	2,41	0,52
52M2C40A - 52M8C40A	650	-	30	4	27	1,65	0,52
52G2P40A - 52G8P40A	1120	1120	60	25	60	3,58	0,52
52G2C40A - 52G8C40A	600	600	25	11	25	2,30	0,52
52R2P40A - 52R8P40A	1200	2000	190	67	118	5,89	0,74
52R2C40A - 52R8C40A	1200	2000	85	67	72	3,84	0,74
52M2P50A - 52M8P50A	800	-	80	17	74	5,30	0,96
52M2C50A - 52M8C50A	800	-	38	17	32	3,50	0,96
52G2P50A - 52G8P50A	1550	1500	200	70	200	7,28	0,96
52G2C50A - 52G8C50A	820	800	60	40	60	4,63	0,96
52M2P63A - 52M8P63A	1400	-	110	17	100	8,10	1,32
52M2C63A - 52M8C63A	1400	-	50	17	48	5,40	1,32
52G2P63A - 52G8P63A	2200	2000	300	102	300	11,02	1,32
52G2C63A - 52G8C63A	1100	1100	105	56	105	7,10	1,32

END CUSHION DIAGRAM AND LOAD ADJUSTMENT COEFFICIENTS

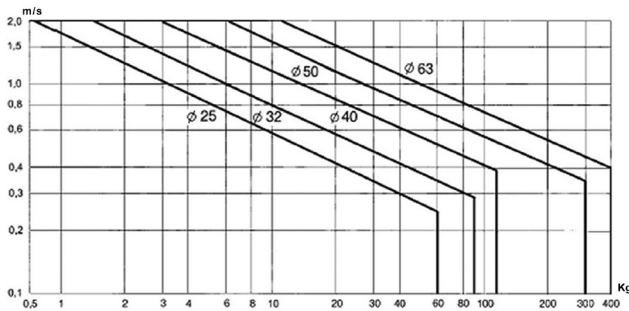

The end cushion regulating screw has to be regulated to obtain a smooth movement at the end of stroke. In those applications which have different values than the ones stated in the diagram, external shock-absorbers have to be used. The shock-absorber should be centrally located with respect to the center of the mass. The diagram applies for horizontal operations.

LOAD ADJUSTMENT COEFFICIENTS

Speed	Coefficient
0,2 m/s	1
0,3 m/s	0,75
0,4 m/s	0,5
0,5 m/s	0,4
0,75 m/s	0,27
1 m/s	0,2

LOADS ACCORDING TO SUPPORTS DISTANCE

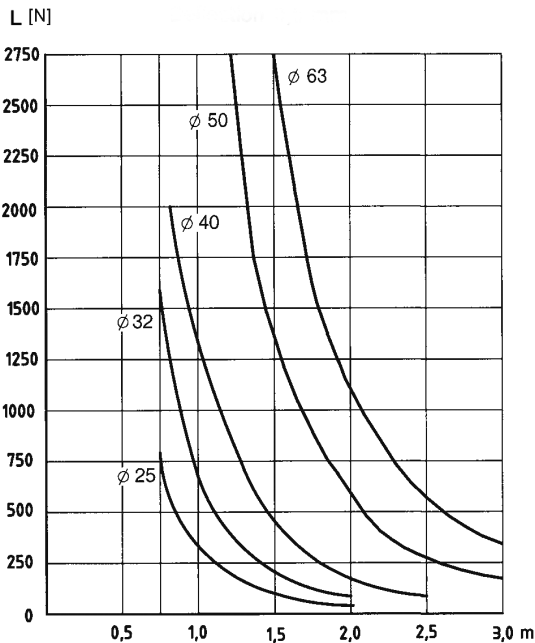

DEFLECTION 0.5 mm
The charts have been made according to a max. deflection of 0.5 mm and 1 mm when a load (N) is applied. The charts give the max distance between two supports in order to stay within the deflection range given.

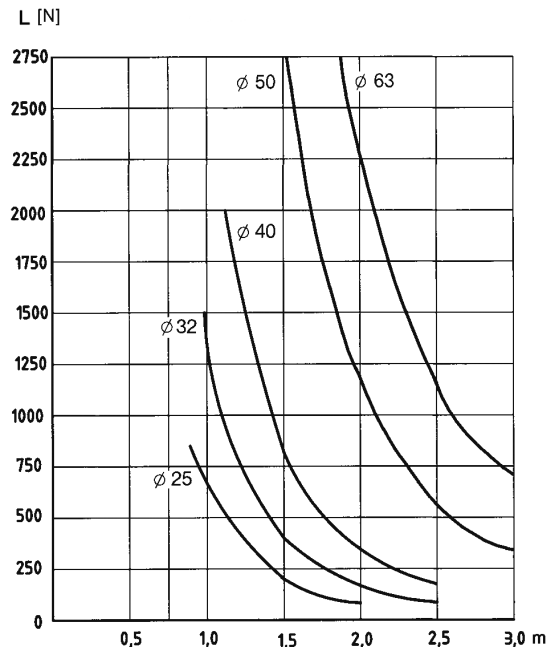

DEFLECTION 1 mm
The charts have been made according to a max. deflection of 0.5 mm and 1 mm when a load (N) is applied. The charts give the max distance between two supports in order to stay within the deflection range given.

Cylinders with standard carriage Mod. 52M2P

The cylinder has two supply ports "I" for both endcovers. The operator needs to choose which one of the two ports to use on each endcover. The remaining port has to be closed with the supplied tap.

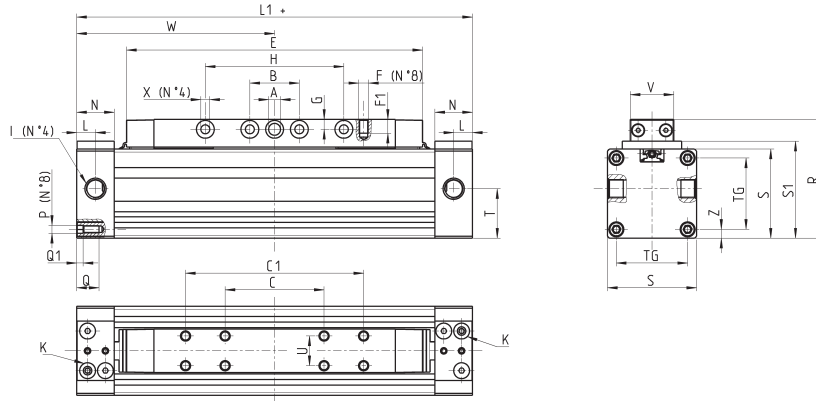

+ = add the stroke
K = cushion regulation screw



DIMENSIONS																											
Mod.	∅	W	E	L1	I	B	G	N	L	ρ_A	ρ_X	S1	T	Z	C1	C	U	F	F1	H	V	S	R	P	TG	Q	Q1
52M2P25A	25	100	149,5	200	G1/8	25	5	19	9,5	6	4,5	49	25	4,5	90	50	15	M5	7	70	22	45	60	M4	36	11	3
52M2P32A	32	120	184,5	240	G1/8	25	5,5	19	9,5	6	5,5	58	32	7,5	130	45	15	M5	7	100	22	54	69	M5	41	11	4
52M2P40A	40	150	222,5	300	G1/4	25	7	23	11,5	7	6,5	68	38	7,5	160	90	15	M5	9	130	22	64	82	M6	49	12	4
52M2P50A	50	175	262	350	G3/8	35	9	30	17	10	8,5	94	59	12,5	150	60	34	M8	16	180	46	90	115	M8	65	17	5
52M2P63A	63	200	300	400	G3/8	50	9,5	30	17	10	8,5	110	68,5	14,0	240	80	34	M8	16	180	46	106	131	M8	78	17	5

Cylinders with standard carriage Mod. 52M8P

The cylinder has six supply ports (I), three for one direction (x-h-w), and the other three (y-z-k) for the opposite direction. With supporting feet (Mod. B-52 / BA-52), ports "h" and "z" have to be closed.

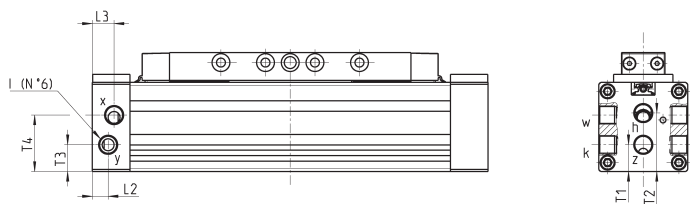

Where no dimensions are presented, refer to dimensions of cylinder model 52M2P.



DIMENSIONS								
Mod.	∅	T1	T2	T3	T4	L2	L3	I
52M8P25A	25	13,5	29,5	13,5	28,5	8	11	G1/8
52M8P32A	32	17,5	34,5	17,5	34,5	9,5	9,5	G1/8
52M8P40A	40	15,5	38	20,5	42,5	11,5	11,5	G1/4
52M8P50A	50	29,5	59	29	59	17	17	G3/8
52M8P63A	63	34	68,5	34	68,5	17	17	G3/8

Cylinders with short carriage Mod. 52M2C

The cylinder has two supply ports "I" for both endcovers. The operator needs to choose which one of the two ports to use on each end cover. The remaining port has to be closed with the supplied tap.

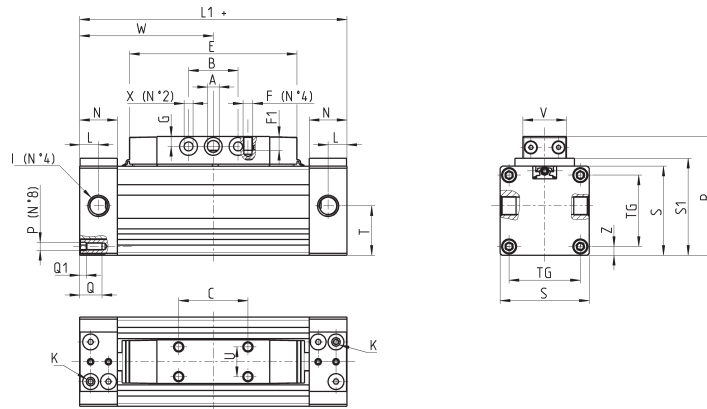

+ = add the stroke
K = cushion regulation screw



DIMENSIONS																									
Mod.	∅	W	L	L1	I	B	G	N	E	A	X	R	C	F	F1	U	T	V	S	S1	TG	P	Z	Q	Q1
52M2C25A	25	67,5	9,5	135	G1/8	25	5	19	84,5	6	4,5	60	35	M5	7	15	25	22	45	49	36	M4	4,5	11	3
52M2C32A	32	77,5	9,5	155	G1/8	25	5,5	19	99,5	6	5,5	69	45	M5	7	15	32,5	22	54	58	41	M5	7,5	11	4
52M2C40A	40	95	11,5	190	G1/4	25	7	23	112,5	7	6,5	82	50	M5	9	15	38,5	22	64	68	49	M6	7,5	12	4
52M2C50A	50	105	17	210	G3/8	35	9	30	122	10	8,5	115	64	M8	16	34	59	46	90	94	65	M8	12,5	17	5
52M2C63A	63	125	17	250	G3/8	50	9,5	30	150	10	8,5	131	80	M8	16	34	68,5	46	106	110	78	M8	14	17	5

Cylinders with short carriage Mod. 52M8C

The cylinder has six supply ports (I), three for one direction (x-h-w), and the other three (y-z-k) for the opposite direction. With supporting feet (Mod. B-52 / BA-52), ports "h" and "z" have to be closed.

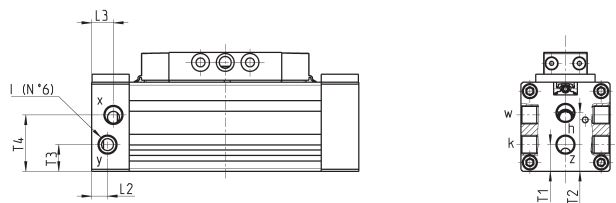

Where no dimensions are presented, refer to dimensions of cylinder model 52M2C.



DIMENSIONS								
Mod.	∅	T1	T2	T3	T4	L2	L3	I
52M8C25A	25	13,5	29,5	13,5	28,5	8	11	G1/8
52M8C32A	32	17,5	34,5	17,5	34,5	9,5	9,5	G1/8
52M8C40A	40	15,5	38	20,5	42,5	11,5	11,5	G1/4
52M8C50A	50	29,5	59	29	59	17	17	G3/8
52M8C63A	63	34	68,5	34	68,5	17	17	G3/8

Cylinders with slide bearing Mod. 52G2P

The cylinder has two supply ports "I" for both endcovers. The operator needs to choose which one of the two ports to use on each end cover. The remaining port has to be closed with the supplied tap.



jj = these holes are present in cylinder Ø32 only + add the stroke
K = cushion regulation screw

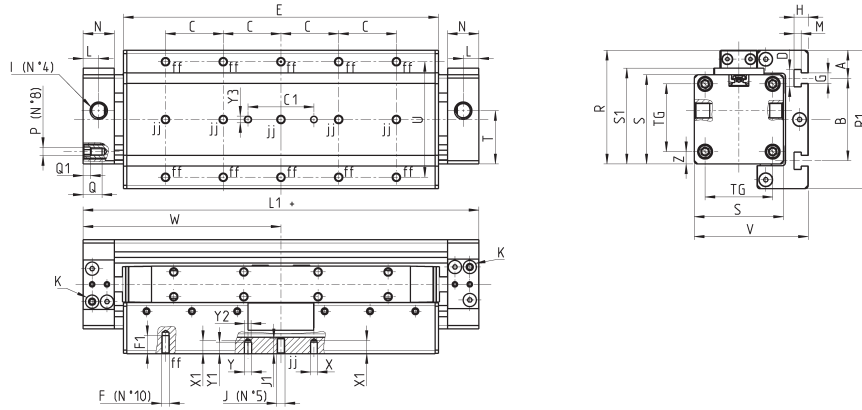

DIMENSIONS

Mod.	∅	W	E	L1	I	L	T	U	N	C	F	F1	D	B	A	H	G	M	J	J1	TG	Z	S	R1	P	V	Q	Q1	Y2	Y	X	Y1	X1	Y3	C1	S1	R
52G2P25A	25	100	159	200	G1/8	9,5	25	30	19	30	M5	8	10,5	50	12,5	8,5	6,5	4,5	-	-	36	4,5	45	75	M4	59	11	3	4	4,5	4	4,5	5,5	4	40	49	60
52G2P32A	32	120	191	240	G1/8	9,5	32,5	70	19	35	M5	11	10,5	50	17	8,5	6,5	4,5	M5	9	41	7,5	54	84	M5	69	11	4	4	4,5	4	7	8	4	40	58	69
52G2P40A	40	150	246	300	G1/4	11,5	38	55	23	55	M6	12	10,5	80	10	8,5	6,5	4,5	-	-	49	7,5	64	100	M6	79	12	4	6	6,5	6	7	8	6	40	68	82
52G2P50A	50	175	270	350	G3/8	17	59	42	30	50	M8	16	10,5	94	23	8,5	6,5	4,5	-	-	65	12,5	90	133	M8	112,5	17	5	-	6,5	6	3	3	6	40	94	115
52G2P63A	63	200	320	400	G3/8	17	68,5	60	30	60	M8	16	10,5	110	24	8,5	6,5	4,5	-	-	78	14	106	150	M8	134,5	17	5	-	6,5	6	6,5	6,5	6	40	110	132

Cylinders with slide bearing Mod. 52G8P

The cylinder has six supply ports (I), three for one direction (x-h-w), and the other three (y-z-k) for the opposite direction. With supporting feet (Mod. B-52 / BA-52), ports "h" and "z" have to be closed.



Where no dimensions are presented, refer to dimensions of cyl. mod. 52G2P. The guide can be applied on the right side, if requested.

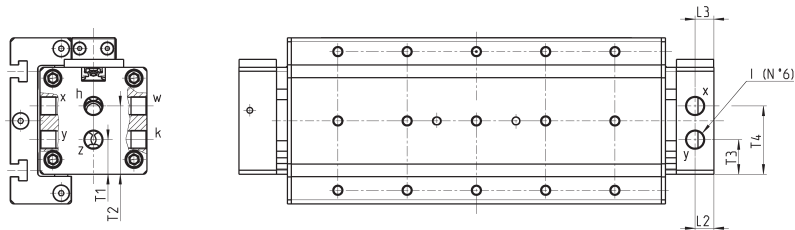

DIMENSIONS

Mod.	∅	T1	T2	T3	T4	L2	L3	I
52G8P25A	25	13,5	29,5	13,5	28,5	8	11	G1/8
52G8P32A	32	17,5	34,5	17,5	34,5	9,5	9,5	G1/8
52G8P40A	40	15,5	38	20,5	42,5	11,5	11,5	G1/4
52G8P50A	50	29,5	59	29	59	17	17	G3/8
52G8P63A	63	34	68,5	34	68,5	17	17	G3/8

Cylinders with slide bearing Mod. 52G2C

The cylinder has two supply ports "I" for both endcovers. The operator needs to choose which one of the two ports to use on each end cover. The remaining port has to be closed with the supplied tap.



jj = these holes are present in cylinder Ø32 only
 + add the stroke
 K = cushion regulation screw
 The drawing show Ø32

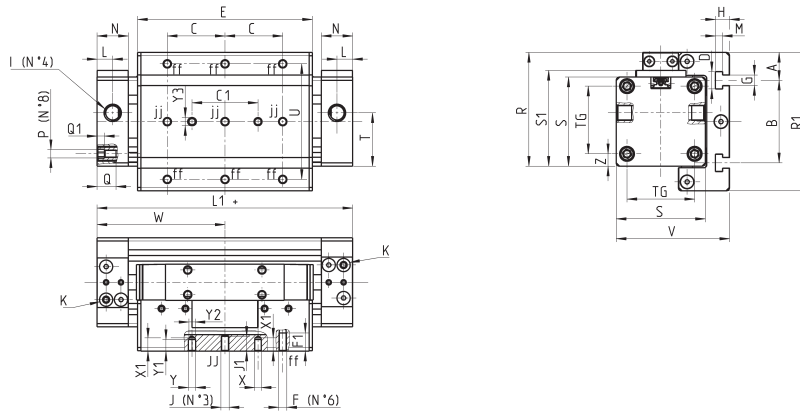

DIMENSIONS																																					
Mod.	Ø	W	E	L1	I	L	T	U	N	C	F	F1	D	B	A	H	G	M	J	J1	TG	Z	S	R1	P	V	Q	Q1	Y2	Y	X	Y1	X1	Y3	C1	S1	R
52G2C25A	25	67,5	94	135	G1/8	9,5	25	30	19	30	M5	8	10,5	50	12,5	8,5	6,5	4,5	-	-	36	4,5	45	75	M4	59	11	3	4	4,5	4	4,5	5,5	4	40	49	60
52G2C32A	32	77,5	106	155	G1/8	9,5	32,5	70	19	35	M5	11	10,5	50	17	8,5	6,5	4,5	M5	9	41	7,5	54	84	M5	69	11	4	4	4,5	4	7	8	4	40	58	69
52G2C40A	40	95	136	190	G1/4	11,5	38,5	55	23	55	M6	12	10,5	80	10	8,5	6,5	4,5	-	-	49	7,5	64	100	M6	79	12	4	6	6,5	6	7	8	6	40	68	82
52G2C50A	50	105	148	210	G3/8	17	59	42	30	50	M8	16	10,5	94	23	8,5	6,5	4,5	-	-	65	12,5	90	133	M8	113	17	5	-	6,5	6	3	3	6	40	94	115
52G2C63A	63	125	180	250	G3/8	17	68,5	60	30	60	M8	16	10,5	110	24	8,5	6,5	4,5	-	-	78	14	106	150	M8	134,5	17	5	-	6,5	6	6,5	6,5	6	40	110	132

Cylinders with slide bearing Mod. 52G8C

The cylinder has six supply ports (I), three for one direction (x-h-w), and the other three for the opposite direction (y-z-k). With supporting feet (mod. B-52 / BA-52), ports "h" and "z" have to be closed.



Where no dimensions are presented, refer to dimensions of cylinder model 52G2C. The guide can be applied on the right side, if requested.

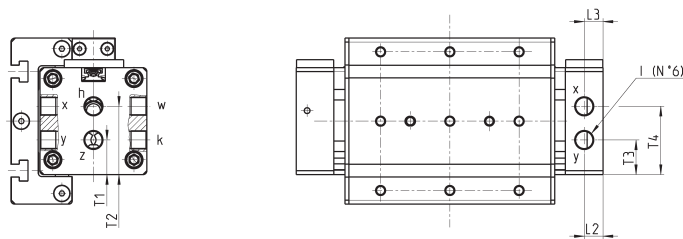

DIMENSIONS								
Mod.	Ø	T1	T2	T3	T4	L2	L3	I
52G8C25A	25	13,5	29,5	13,5	28,5	8	11	G1/8
52G8C32A	32	17,5	34,5	17,5	34,5	9,5	9,5	G1/8
52G8C40A	40	15,5	38	20,5	42,5	11,5	11,5	G1/4
52G8C50A	50	29,5	59	29	59	17	17	G3/8
52G8C63A	63	34	68,5	34	68,5	17	17	G3/8

Cylinders with roller bearings Mod. 52R2P

The cylinder has two supply ports "I" for both endcovers. The operator needs to choose which one of the two ports to use on each end cover. The remaining port has to be closed with the supplied tap.



ff = these holes are not present in cylinder Ø 25
+ add the stroke
K = cushion regulation screw

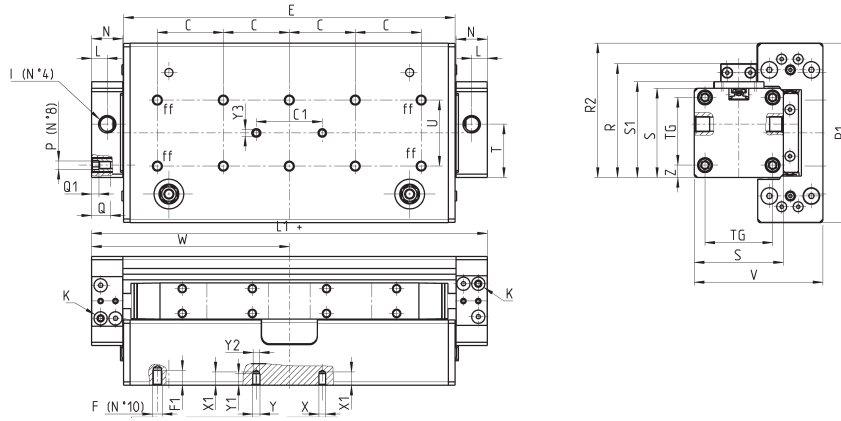

DIMENSIONS

Mod.	Ø	W	E	L1	I	L	T	U	N	C	F	F1	TG	Z	S	R1	P	V	Q	Q1	ØY2	Y	ØX	Y1	X1	Y3	C1	S1	R2	R
52R2P25A	25	100	160	200	G1/8	9.5	25	40	19	40	M5	7.5	36	4.5	45	97	M4	68	11	3	4	4.5	4	7	8	4	40	49	71	60
52R2P32A	32	120	201	240	G1/8	9.5	32.5	40	19	40	M6	9	41	7.5	54	109	M5	78	11	4	4	4.5	4	7	8	4	40	58	81.5	69
52R2P40A	40	150	252	300	G1/4	11.5	38	55	23	55	M6	12	49	7.5	64	145	M6	90.5	12	4	6	6.5	6	7	8	6	40	68	104.5	82

Cylinders with roller bearings Mod. 52R8P

The cylinder has six ports, three for one direction (x-h-w), and the other three (y-z-k) for the opposite direction. With supporting feet (Mod. B-52 / BA-52), ports "h" and "z" have to be closed.



Where no dimensions are presented, refer to dimensions of cylinder model 52R2P. The guide can be applied on the right side, if requested.

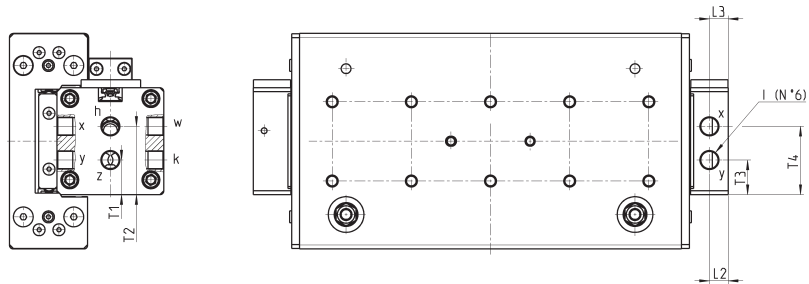

DIMENSIONS

Mod.	Ø	T1	T2	T3	T4	L2	L3	I
52R8P25A	25	13,5	29,5	13,5	28,5	8	11	G1/8
52R8P32A	32	17,5	34,5	17,5	34,5	9,5	9,5	G1/8
52R8P40A	40	15,5	38	20,5	42,5	11,5	11,5	G1/4

Cylinders with roller bearings Mod. 52R2C

The cylinder has two supply ports "I" for both endcovers. The operator needs to choose which one of the two ports to use on each end cover. The remaining port has to be closed with the supporting tap.



+ = add the stroke
K = cushion regulation screw

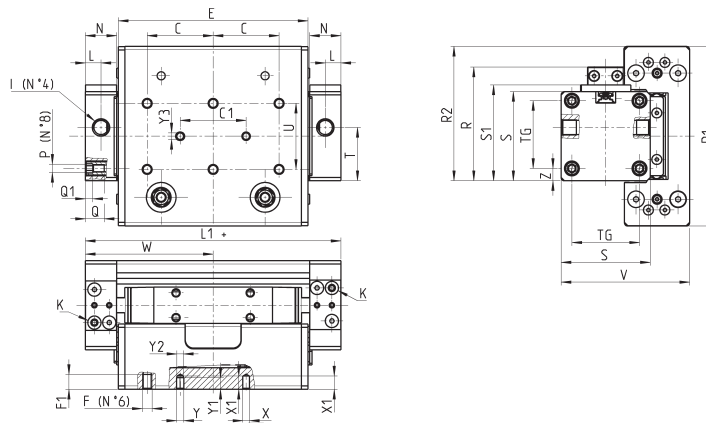

DIMENSIONS																														
Mod.	∅	W	E	L1	I	L	T	U	N	C	F	F1	TG	Z	S	R1	P	V	Q	Q1	Y2	Y	X	Y1	X1	Y3	C1	S1	R2	R
52R2C25A	25	67.5	95	135	G1/8	9.5	25	40	19	20	M5	7.5	36	4.5	45	97	M4	68	11	3	4	4.5	4	7	8	4	40	49	71	60
52R2C32A	32	77.5	115	155	G1/8	9.5	32.5	40	19	40	M6	9	41	7.5	54	109	M5	78	11	4	4	4.5	4	7	8	4	40	58	81.5	69
52R2C40A	40	95	143.5	190	G1/4	11.5	38	55	23	55	M6	12	49	7.5	64	145	M6	90.5	12	4	6	6.5	6	7	8	6	40	68	104.5	82

Cylinders with roller bearings Mod. 52R8C

The cylinder has six supply ports (I), three for one direction (x-h-w), and the other three (y-z-k) for the opposite direction. With supporting feet (Mod. B-52 / BA-52), ports "h" and "z" have to be closed.

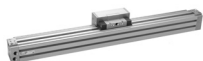

Where no dimensions are presented, refer to dimensions of cylinder model 52R2C. The guide can be applied on the right side, if requested.

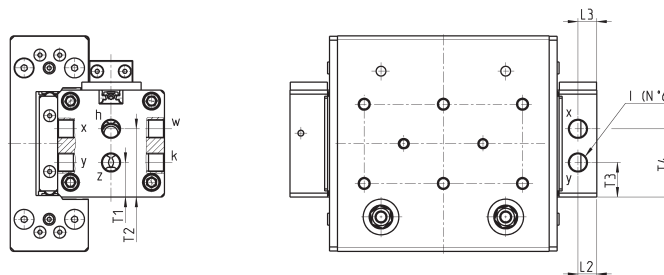

DIMENSIONS									
Mod.	∅	T1	T2	T3	T4	L2	L3	I	
52R8C25A	25	13,5	29,5	13,5	28,5	8	11	G1/8	
52R8C32A	32	17,5	34,5	17,5	34,5	9,5	9,5	G1/8	
52R8C40A	40	15,5	38	20,5	42,5	11,5	11,5	G1/4	

Foot mount Mod. B-52



The following is supplied:
2x feet
4x screws

+ = add the stroke

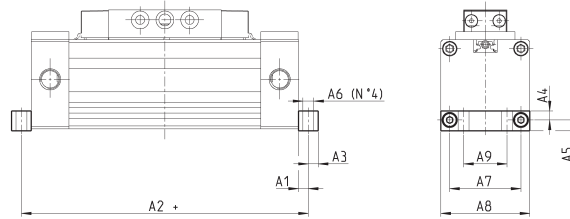

DIMENSIONS											
Mod.	∅	A1	A2 Series 52...P...	A2 Series 52...C...	A3	A4	A5	∅ A6	A7	A8	A9
B-52-25	25	5	210	145	5	4,5	5,5	5,5	36	45	22
B-52-32	32	7,5	255	170	7,5	7,5	8,5	7	41	51	25
B-52-40	40	7,5	315	205	7,5	7,5	8,5	9	49	64	25
B-52-50	50	7,5	365	225	7,5	12,5	13,5	8.5	65	89	40
B-52-63	63	7,5	415	265	7,5	14	15	8.5	78	105	50

Foot mount Mod. BA-52

These are to be used with intermediate bracket (Mod. BH-52... and BL-52...)



The following is supplied:
2x feet
4x screws

+ = add the stroke

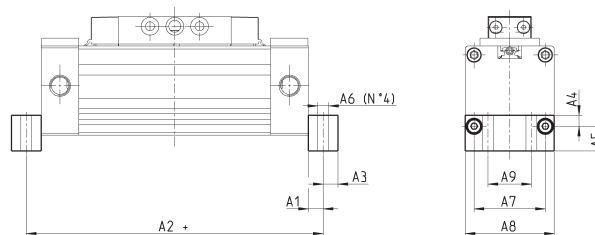

DIMENSIONS											
Mod.	∅	A1	A2 Series 52...P...	A2 Series 52...C...	A3	A4	A5	∅ A6	A7	A8	A9
BA-52-25	25	5	215	150	5	5,5	12,5	5,5	36	45	22
BA-52-32	32	7,5	255	170	7,5	16,5	17,5	7	41	51	25
BA-52-40	40	7,5	315	205	7,5	8,5	17,5	9	49	64	25
BA-52-50	50	7,5	365	225	7,5	12,5	27,5	8,5	65	89	40
BA-52-63	63	7,5	415	265	7,5	11	29	8,5	78	105	50

Intermediate brackets Mod. BH and BL 52-32

Assembling by using two intermediate brackets without using the feet bracket.



The following is supplied:
1x intermediate bracket
4x screws

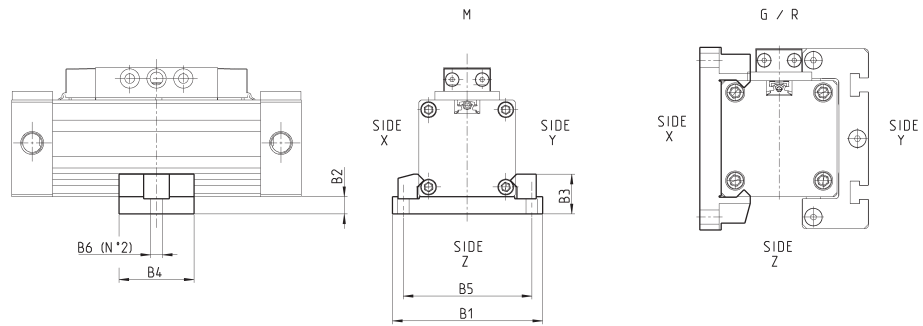

DIMENSIONS								
Mod.	∅	B1	B2	B3	B4	B5	∅ B6	
BH-52-25	25	70	8	18.5	35	60	5.5	for cylinders vers. M mounting on sides X, Y, Z - for cylinders vers. G or R mounting on sides X and Y
BH-52-32	32	85	10	23.5	40	73	6.5	for cylinders vers. M mounting on side Z
BL-52-32	32	85	10	23.5	40	73	6.5	for cylinders vers. M, G or R mounting on sides X and Y
BH-52-40	40	105	10	23.5	40	90.5	9	for cylinders vers. M mounting on sides X, Y, Z - for cylinders vers. G or R mounting on sides X and Y
BH-52-50	50	138	15	30	70	120	11	for cylinders vers. M mounting on sides X, Y, Z - for cylinders vers. G or R mounting on sides X and Y
BH-52-63	63	154	15	36	70	136	11	for cylinders vers. M mounting on sides X, Y, Z - for cylinders vers. G or R mounting on sides X and Y

Self-compensating adaptor Mod. CF-52

The self-compensating adaptor is used to compensate the difference between the rodless cylinder and the external guide system. Suitable for cylinders mod. 52M2P/52M2C/52M8P/52M8C.



The following is supplied:
1x adaptor
1x pin
2x feet
2x seeger

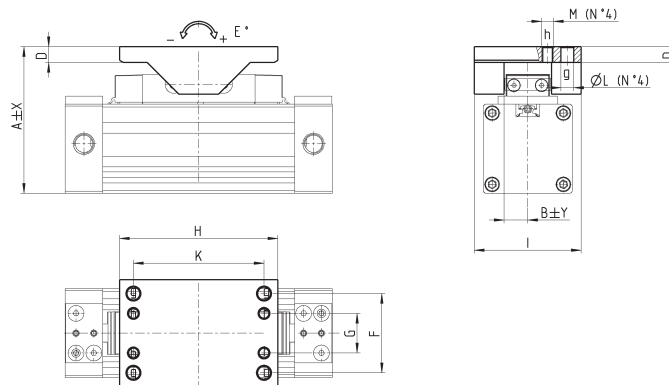

DIMENSIONS														
Mod.	∅	A	X	E°	B	Y	D	I	F	G	H	K	∅L	M
CF-52-25-32	25	74	1	±8	12	0,8	8	54	40	20	80	66	6,5	M6
CF-52-25-32	32	82	0,5	±6	12	0,8	8	54	40	20	80	66	6,5	M6
CF-52-40	40	94,5	0,5	±6	12	0,8	8	54	40	20	80	66	6,5	M6
CF-52-50-63	50	130,5	0,5	±5	24	0,8	11	80	51	23	122	102	9	M8
CF-52-50-63	63	146	0,5	±4,5	24	0,8	11	80	51	23	122	102	9	M8