

Series CGPS Parallel grippers with double ball bearing guide

Single and double acting, magnetic, self-centering
Bores: Ø 10, 16, 20, 25, 32 mm



Thanks to the use of a high performing and precise force transmission system and to the double ball bearing guide, the Series CGPS grippers are able to provide high gripping forces while guaranteeing a very high repeatability and robustness (resistance to external static and dynamic loads).

The wide range of sizes available allows you to find the best solution for any handling need. The grippers can be supplied with bushes and centering plugs (tolerance H8) which, once positioned on the body and/or on the jaws, are able to guarantee, during maintenance, a high interchangeability of the gripper and of the extensions.

- » Robust, compact and light design
- » High closing/opening forces
- » Fixing from below and from the side
- » Supply on the side
- » Self-centering jaws
- » High closing and opening repeatability
- » High interchangeability (bushes and centering plugs)
- » Position detection (front and side) thanks to the use of Series CSD magnetic proximity switches
- » Protection against dust (IP40)
- » Finger types available: long with through-holes and flat with threaded holes
- » High resistance to external loads thanks to the double ball bearing guide
- » Variants available: for use in ATEX zones and for high temperatures

GENERAL DATA

Type of construction	Self-centering parallel gripper with double ball bearing guide
Operation	Single acting (NO, NC), double acting
Bores	Ø 10, 16, 20, 25, 32 mm
Force transmission	Lever
Air connections	M3-M5 (M3 for size 10 only)
Working pressure	2 ÷ 8 bar (double acting), 4 ÷ 8 bar (single acting)
Working temperature	5°C ÷ 60°C (standard); 5°C ÷ 150°C (high temperature version)
Store temperature	-10°C ÷ 80°C
Maximum use frequency	3 Hz
Repeatability	0.02 mm
Interchangeability	0.1 mm
Medium	Filtered air in class 7.4.4 according to ISO 8573-1. In case lubricated air is used, we recommend ISOVG32 oil and to never interrupt lubrication.
Compatibility	ROHS Directive
Certifications	ATEX (II 2GD c IIC 120°C(T4)-20°C≤Ta≤80)
Materials	PTFE, Silicone and Copper free
Suitable magnetic proximity switches	Series CSD

NOTE: Pressurize the pneumatic system gradually in order to avoid uncontrolled movements

CODING EXAMPLE

CGPS	-	L	-	16	-	NO	-	W	EX
-------------	----------	----------	----------	-----------	----------	-----------	----------	----------	-----------

CGPS	SERIES								
L	DESIGN TYPE: L = Long finger F = Flat finger								
16	BORES: 10 = ø 10 mm 16 = ø 16 mm 20 = ø 20 mm 25 = ø 25 mm 32 = ø 32 mm								
NO	FUNCTIONING: = double acting NO = single acting, normally open NC = single acting, normally closed						PNEUMATIC SYMBOLS PNZ1 PNZ3 PNZ2		
W	VERSION: = standard W = high temperatures (150°C) non magnetic								
EX	Add EX to order the certified ATEX version								

SERIES CGPS PARALLEL GRIPPERS

PNEUMATIC SYMBOLS

The pneumatic symbols which have been indicated in the CODING EXAMPLE are shown below.

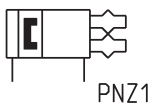

Series CGPS grippers - construction

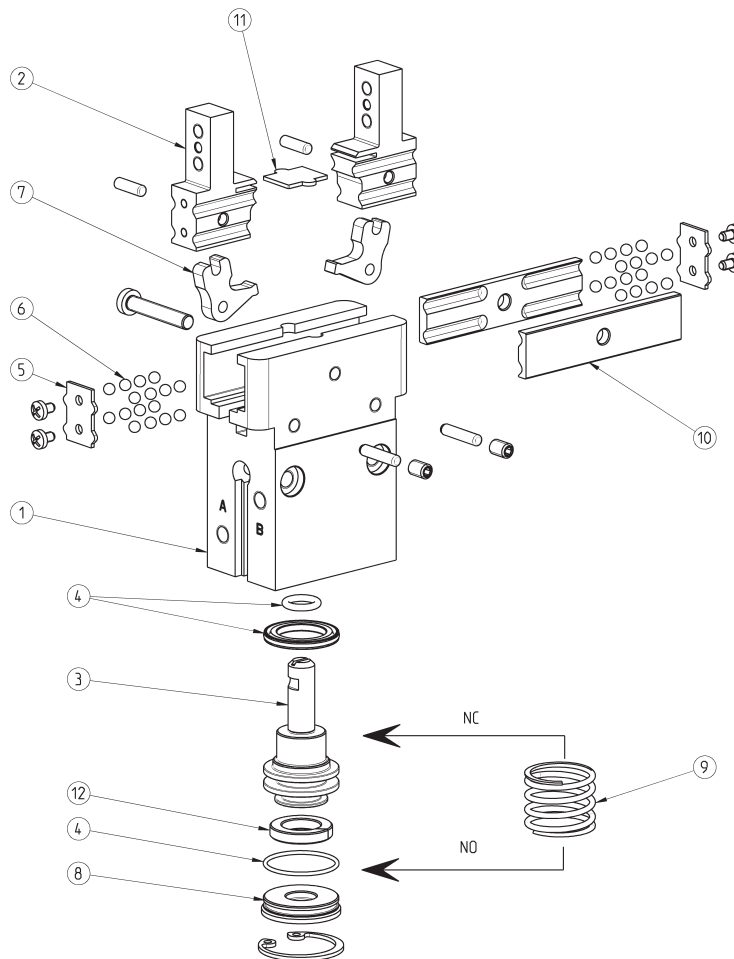

LIST OF COMPONENTS

PARTS	MATERIALS
1 - Body	Aluminium
2 - Jaw	Stainless steel
3 - Piston	Stainless steel
4 - Seals	HNBR / FKM
5 - Ball bearings end cap	Stainless steel
6 - Slide ball bearings	Steel
7 - Levers	Steel
8 - Rear end-stroke	Pom (Acetal)
9 - Spring	Stainless steel
10 - Ball bearings guide	Stainless steel
11 - Jaws end cap	Steel
12 - Magnet	Plastoferrite

CGPS gripper, size 10 mm - dimensions



DRAWING LEGEND:
A = Opening of air connection
B = Closing of air connection
C = Closed gripper
D = Open gripper

SERIES CGPS PARALLEL GRIPPERS

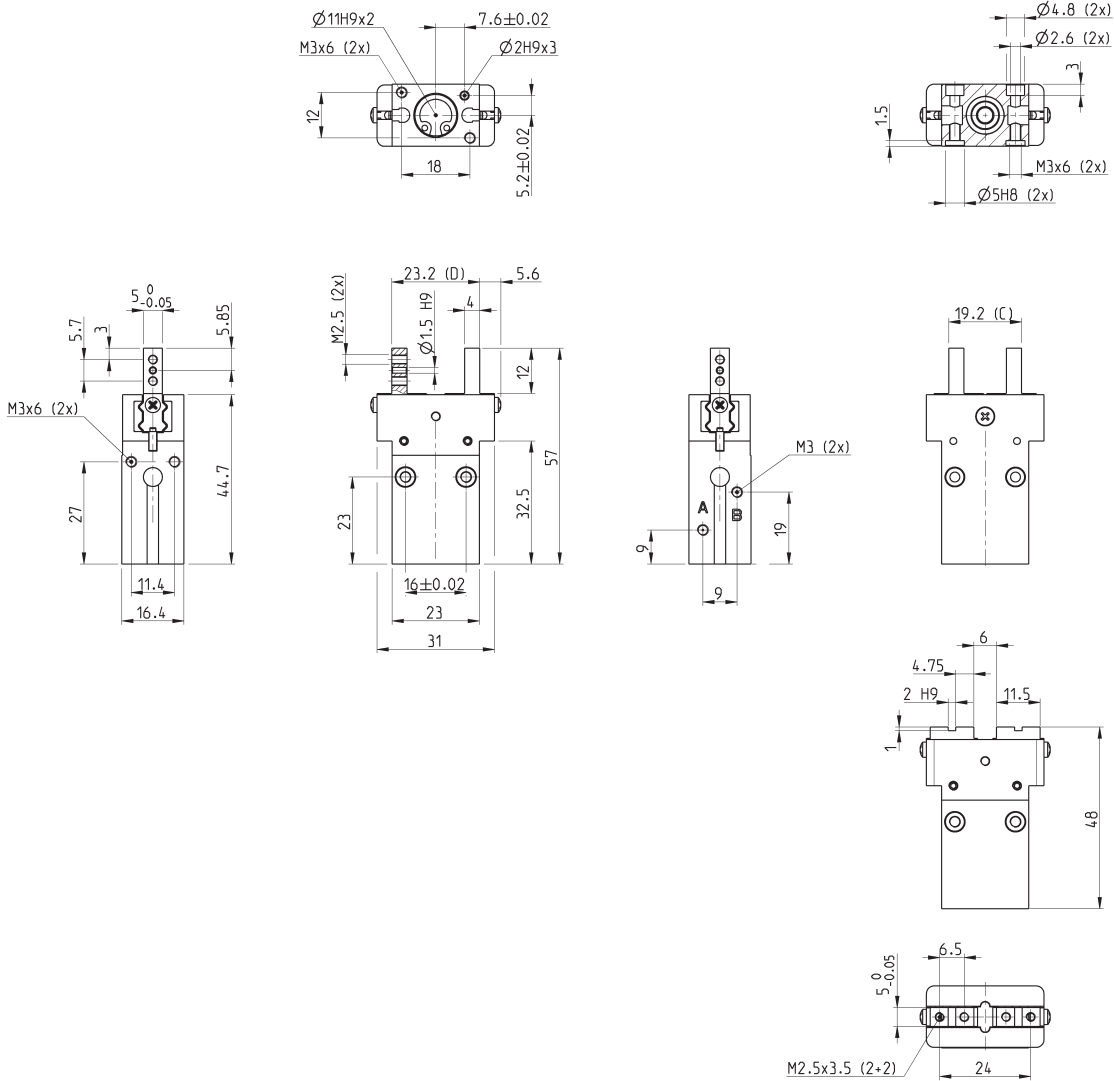

Mod.	Total closing gripping force at 6 bar (N)	Closing gripping force each jaw at 6 bar (N)	Total opening gripping force at 6 bar (N)	Opening gripping force each jaw at 6 bar (N)	Stroke per jaw (mm)	Working pressure (bar)	Working temperature (°C)	Repeatability (mm)	Max use frequency (Hz)	Weight (Kg)
CGPS-L-10	34	17	46	23	2	2 ÷ 8	5 ÷ 60	+/- 0.02	3	0.057
CGPS-F-10	34	17	46	23	2	2 ÷ 8	5 ÷ 60	+/- 0.02	3	0.058
CGPS-L-10-NC	42	21	32	16	2	4 ÷ 8	5 ÷ 60	+/- 0.02	3	0.058
CGPS-F-10-NC	42	21	32	16	2	4 ÷ 8	5 ÷ 60	+/- 0.02	3	0.059
CGPS-L-10-NO	20	10	55	27.5	2	4 ÷ 8	5 ÷ 60	+/- 0.02	3	0.058
CGPS-F-10-NO	20	10	55	27.5	2	4 ÷ 8	5 ÷ 60	+/- 0.02	3	0.059

CGPS gripper, size 16 mm - dimensions



DRAWING LEGEND:

- A = Opening of air connection
- B = Closing of air connection
- C = Closed gripper
- D = Open gripper

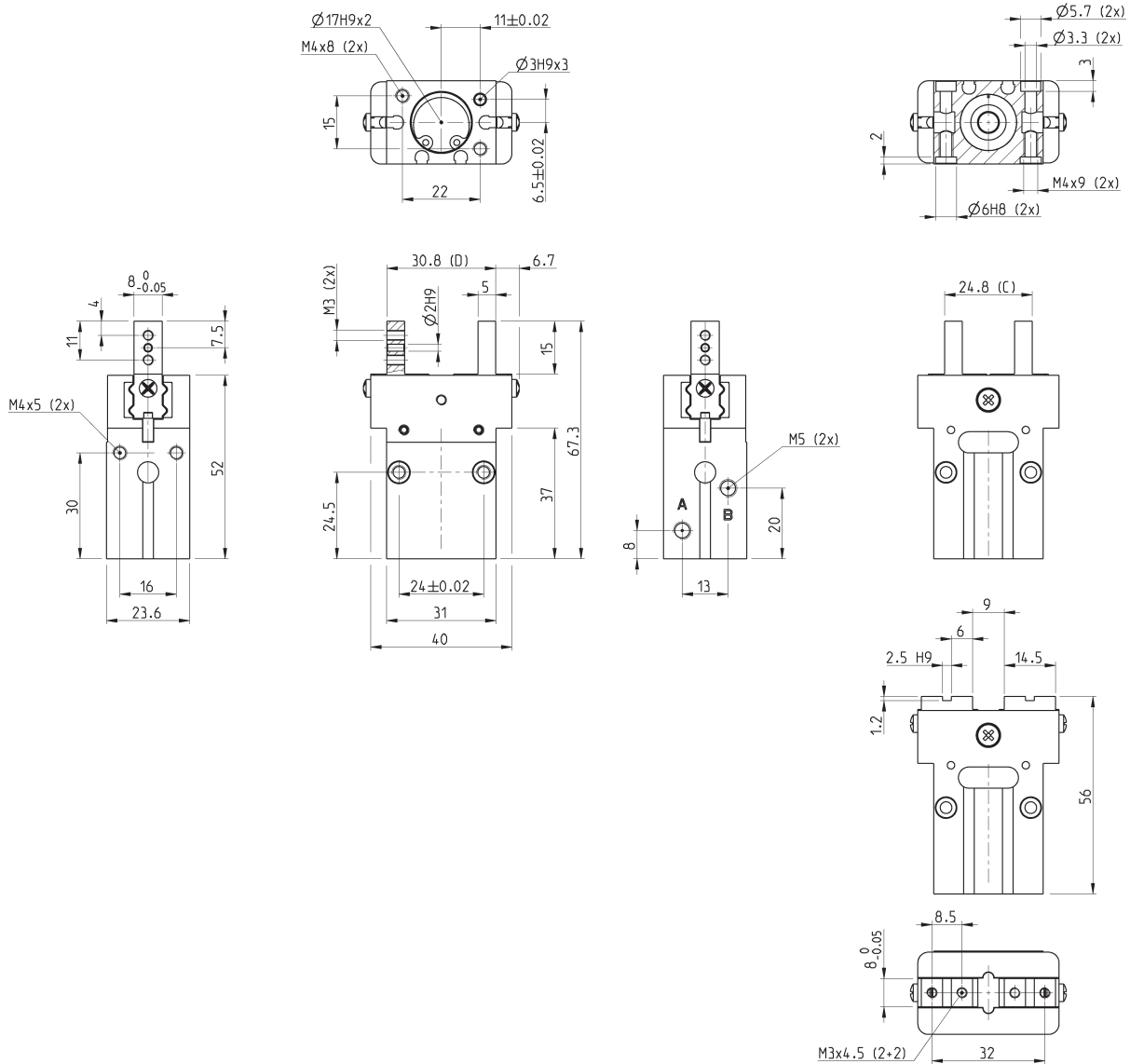

Mod.	Total closing gripping force at 6 bar (N)	Closing gripping force each jaw at 6 bar (N)	Total opening gripping force at 6 bar (N)	Opening gripping force each jaw at 6 bar (N)	Stroke per jaw (mm)	Working pressure (bar)	Working temperature (°C)	Repeatability (mm)	Max use frequency (Hz)	Weight (Kg)
CGPS-L-16	98	49	120	60	3	2 ÷ 8	5 ÷ 60	+/- 0.02	3	0.127
CGPS-F-16	98	49	120	60	3	2 ÷ 8	5 ÷ 60	+/- 0.02	3	0.130
CGPS-L-16-NC	115.4	57.7	95	47.5	3	4 ÷ 8	5 ÷ 60	+/- 0.02	3	0.129
CGPS-F-16-NC	115.4	57.7	95	47.5	3	4 ÷ 8	5 ÷ 60	+/- 0.02	3	0.133
CGPS-L-16-NO	71	35.5	133	68.5	3	4 ÷ 8	5 ÷ 60	+/- 0.02	3	0.129
CGPS-F-16-NO	71	35.5	133	68.5	3	4 ÷ 8	5 ÷ 60	+/- 0.02	3	0.133

Products designed for industrial applications.
General terms and conditions for sale are available on www.camozzi.com.

2.03.05

CGPS gripper, size 20 mm - dimensions



DRAWING LEGEND:
A = Opening of air connection
B = Closing of air connection
C = Closed gripper
D = Open gripper

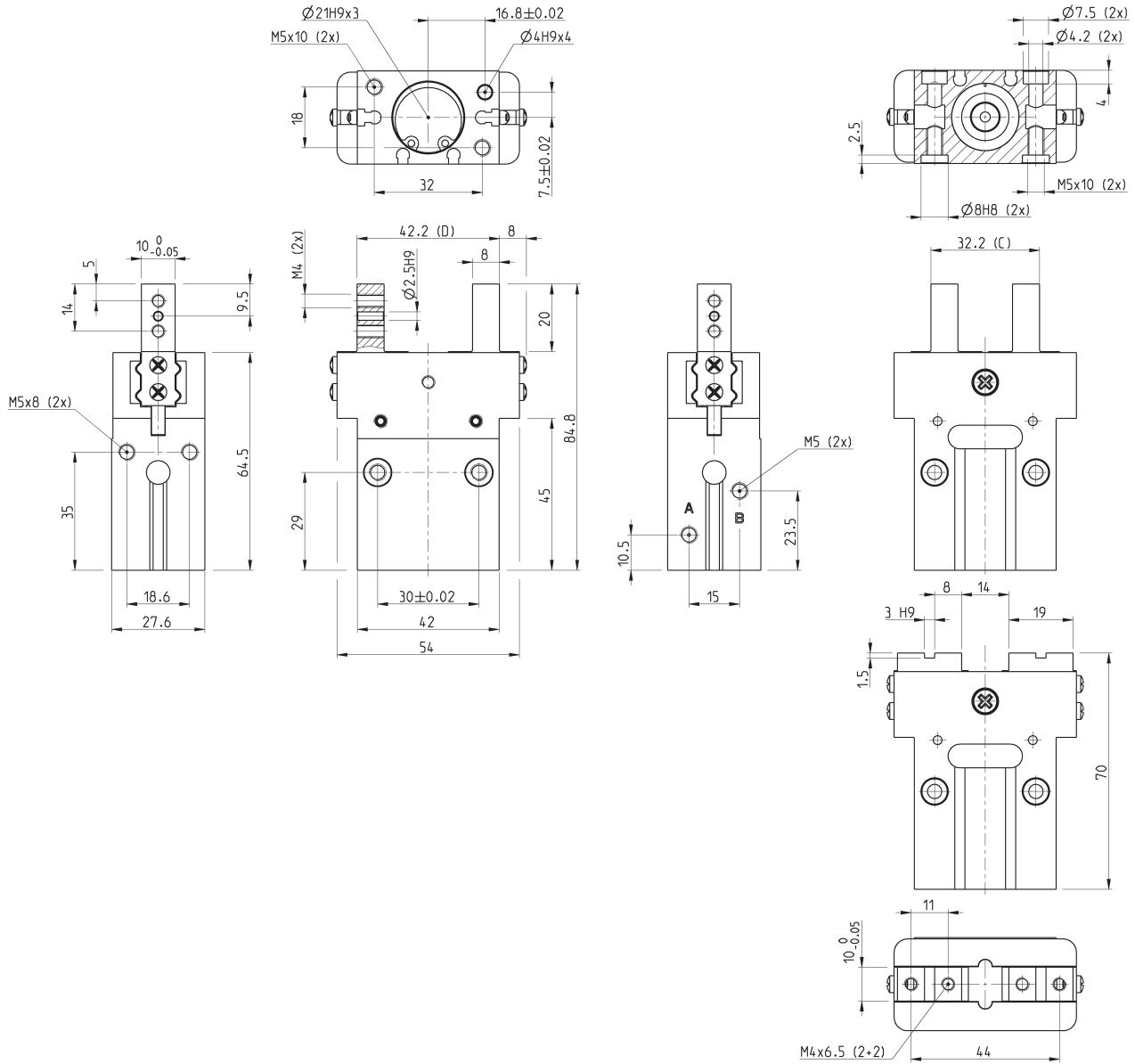

Mod.	Total closing gripping force at 6 bar (N)	Closing gripping force each jaw at 6 bar (N)	Total opening gripping force at 6 bar (N)	Opening gripping force each jaw at 6 bar (N)	Stroke per jaw (mm)	Working pressure (bar)	Working temperature (°C)	Repeatability (mm)	Max use frequency (Hz)	Weight (Kg)
CGPS-L-20	142	71	178	89	5	2 ÷ 8	5 ÷ 60	+/- 0.02	3	0.248
CGPS-F-20	142	71	178	89	5	2 ÷ 8	5 ÷ 60	+/- 0.02	3	0.258
CGPS-L-20-NC	169	84.5	141	70.5	5	4 ÷ 8	5 ÷ 60	+/- 0.02	3	0.252
CGPS-F-20-NC	169	84.5	141	70.5	5	4 ÷ 8	5 ÷ 60	+/- 0.02	3	0.262
CGPS-L-20-NO	103	51.5	205	102.5	5	4 ÷ 8	5 ÷ 60	+/- 0.02	3	0.252
CGPS-F-20-NO	103	51.5	205	102.5	5	4 ÷ 8	5 ÷ 60	+/- 0.02	3	0.262

CGPS gripper, size 25 mm - dimensions



DRAWING LEGEND:
 A = Opening of air connection
 B = Closing of air connection
 C = Closed gripper
 D = Open gripper

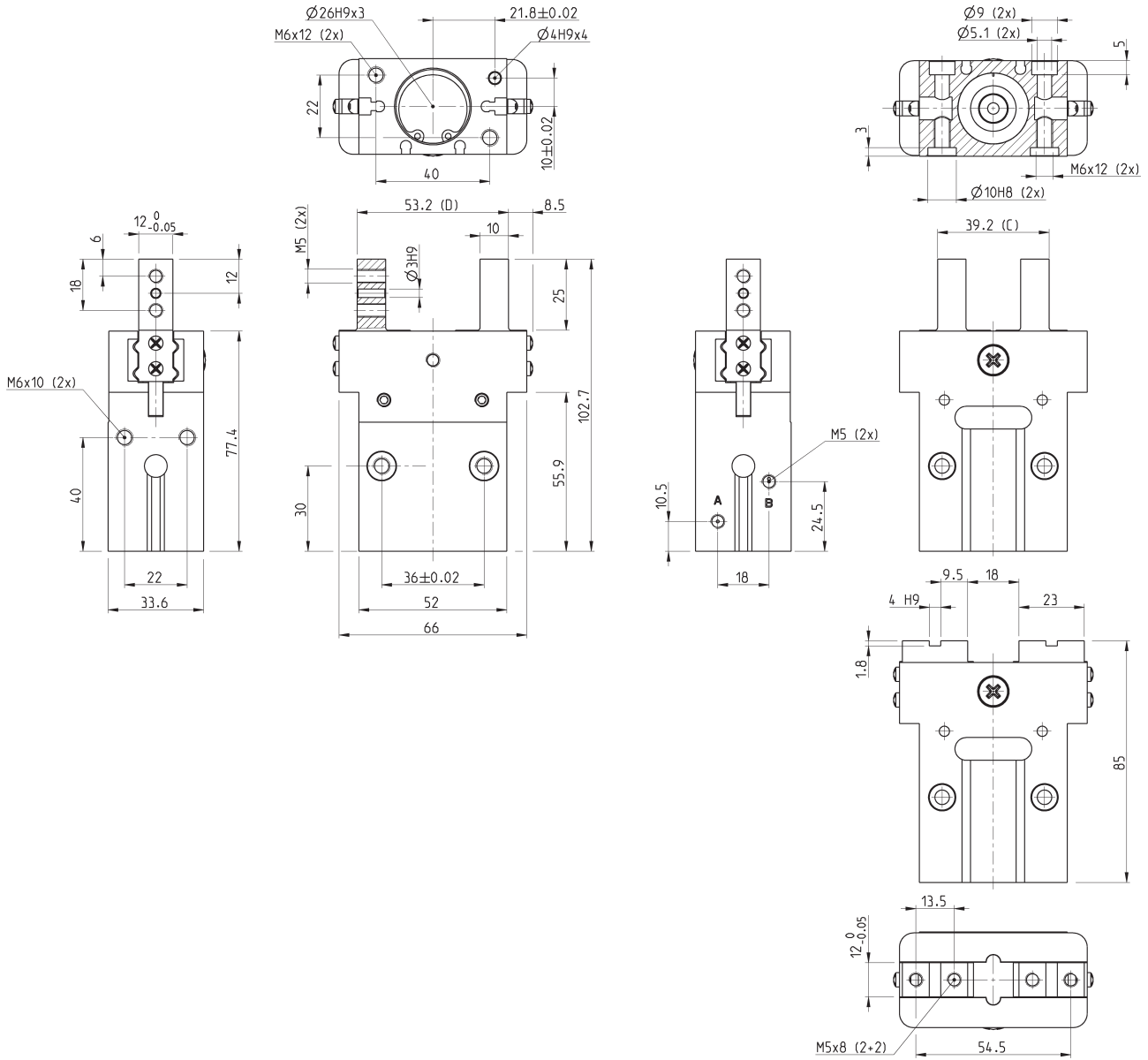

Mod.	Total closing gripping force at 6 bar (N)	Closing gripping force each jaw at 6 bar (N)	Total opening gripping force at 6 bar (N)	Opening gripping force each jaw at 6 bar (N)	Stroke per jaw (mm)	Working pressure (bar)	Working temperature (°C)	Repeatability (mm)	Max use frequency (Hz)	Weight (Kg)
CGPS-L-25	250	125	274	137	7	2 ÷ 8	5 ÷ 60	+/- 0.02	3	0.447
CGPS-F-25	250	125	274	137	7	2 ÷ 8	5 ÷ 60	+/- 0.02	3	0.464
CGPS-L-25-NC	286.4	143.2	222	111	7	4 ÷ 8	5 ÷ 60	+/- 0.02	3	0.456
CGPS-F-25-NC	286.4	143.2	222	111	7	4 ÷ 8	5 ÷ 60	+/- 0.02	3	0.471
CGPS-L-25-NO	200	100	304	152	7	4 ÷ 8	5 ÷ 60	+/- 0.02	3	0.456
CGPS-F-25-NO	200	100	304	152	7	4 ÷ 8	5 ÷ 60	+/- 0.02	3	0.471

CGPS gripper, size 32 mm - dimensions



DRAWING LEGEND:
A = Opening of air connection
B = Closing of air connection
C = Closed gripper
D = Open gripper

SERIES CGPS PARALLEL GRIPPERS

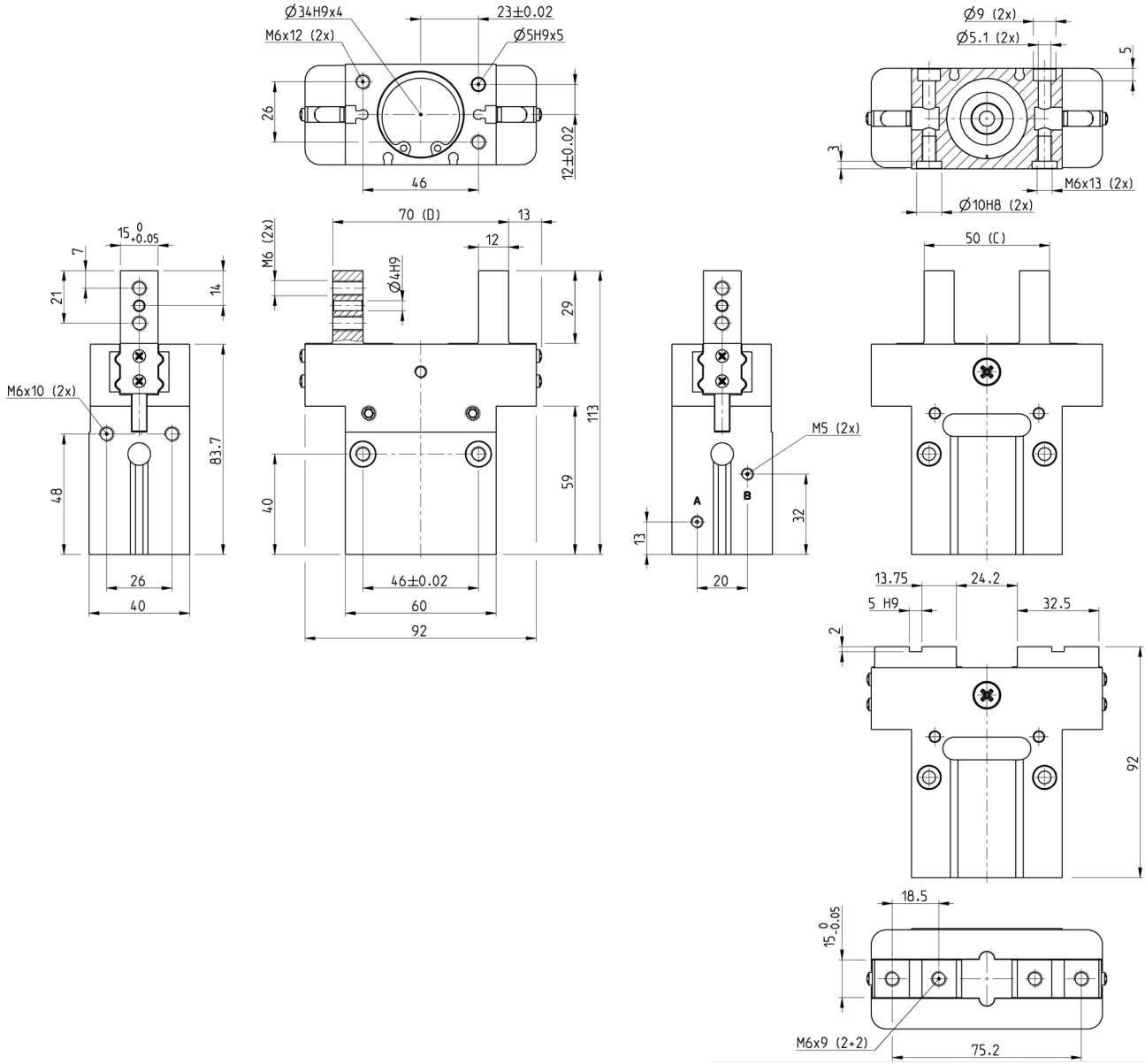

Mod.	Total closing gripping force at 6 bar (N)	Closing gripping force each jaw at 6 bar (N)	Total opening gripping force at 6 bar (N)	Opening gripping force each jaw at 6 bar (N)	Stroke per jaw (mm)	Working pressure (bar)	Working temperature (°C)	Repeatability (mm)	Max use frequency (Hz)	Weight (Kg)
CGPS-L-32	390	195	474	237	10	2 ÷ 8	5 ÷ 60	+/-0.02	2	0.729
CGPS-F-32	390	195	474	237	10	2 ÷ 8	5 ÷ 60	+/-0.02	2	0.753
CGPS-L-32-NC	424	212	420	210	10	4 ÷ 8	5 ÷ 60	+/-0.02	2	0.742
CGPS-F-32-NC	424	212	420	210	10	4 ÷ 8	5 ÷ 60	+/-0.02	2	0.768
CGPS-L-32-NO	334	167	512	256	10	4 ÷ 8	5 ÷ 60	+/-0.02	2	0.742
CGPS-F-32-NO	334	167	512	256	10	4 ÷ 8	5 ÷ 60	+/-0.02	2	0.768

Maximum admissible loads and torques on the gripper

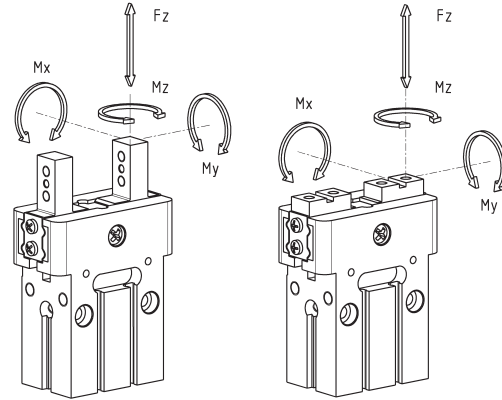

Maximum admissible loads and torques in static conditions

Mod.	Fz (N)	Mx (Nm)	My (Nm)	Mz (Nm)
CGPS-10	90	0.53	2	0.21
CGPS-16	160	1.2	3	0.6
CGPS-20	170	2.4	3.5	1.0
CGPS-25	190	3.5	4.5	1.4
CGPS-32	360	5.5	6	2.5

GRIPPING POINT POSITION

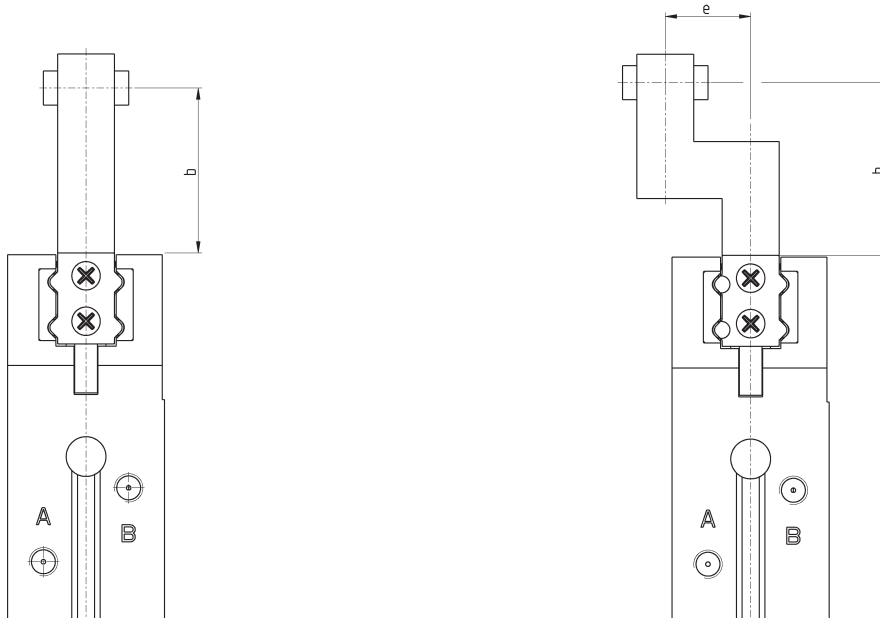

b = gripping point

b = gripping point
e = arm

GRIPPING FORCES Mod. CGPS-...-10

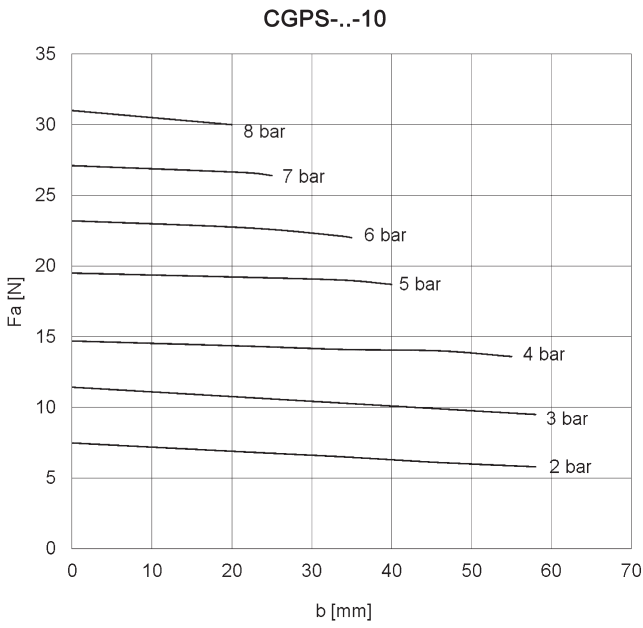

b = gripping point (mm)
Fa = opening gripping force (N)

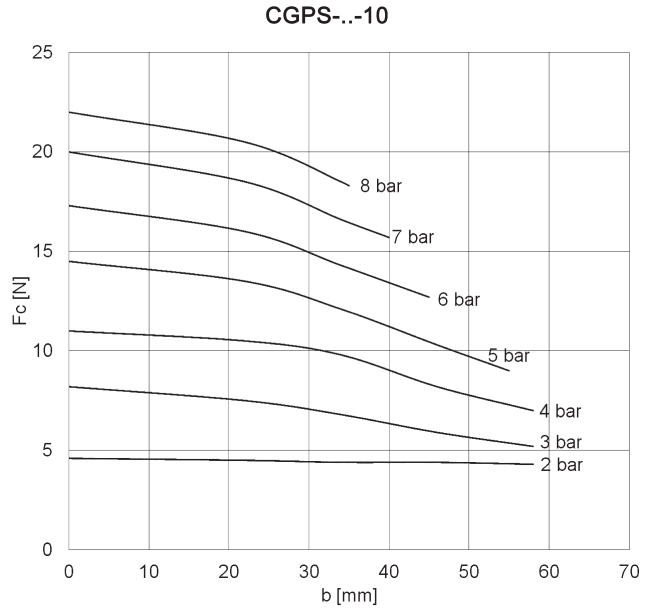

b = gripping point (mm)
Fc = Closing gripping force (N)

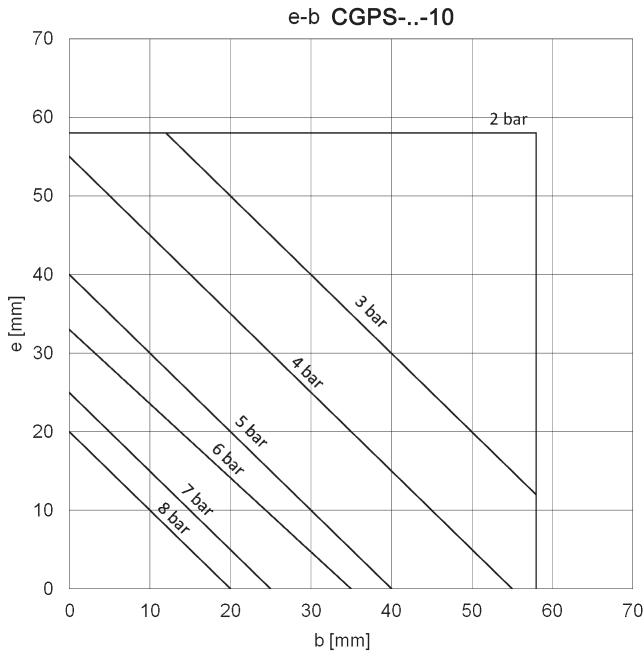

Opening gripping force

b = gripping point (mm)
e = arm (mm)

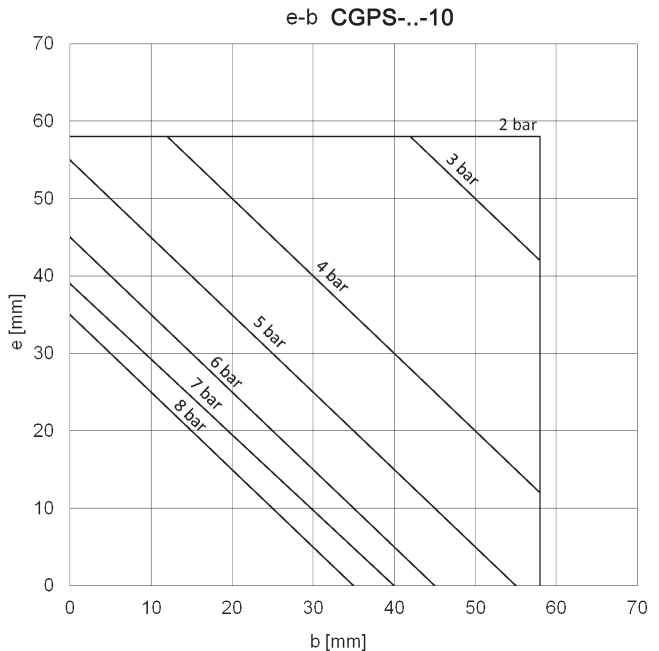

Closing gripping force

b = gripping point (mm)
e = arm (mm)

GRIPPING FORCES Mod. CGPS-...-16

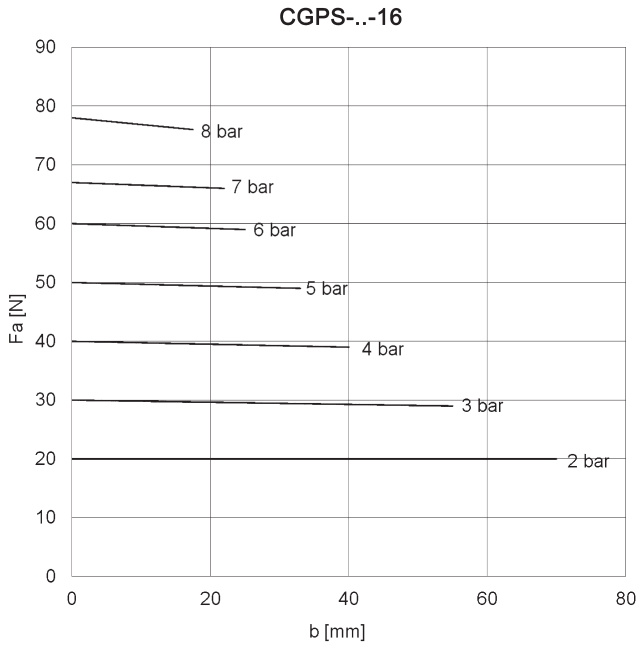

b = gripping point (mm)
Fa = opening gripping force (N)

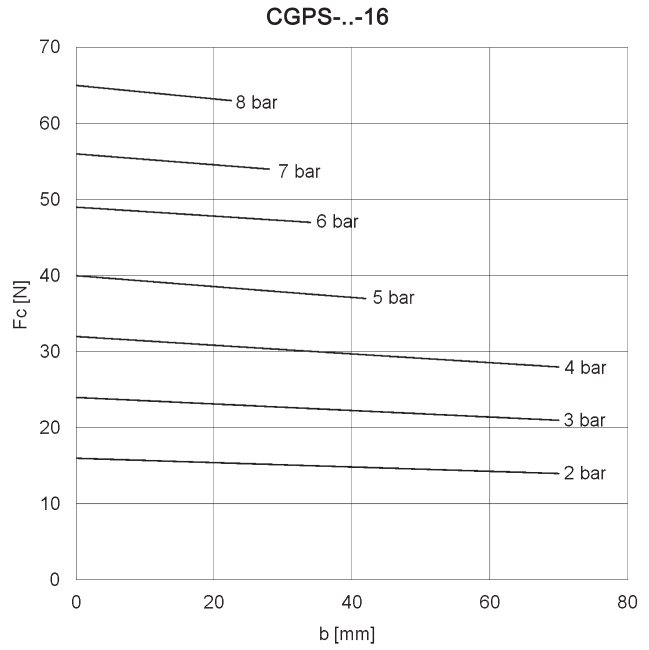

b = gripping point (mm)
Fc = closing gripping force (N)

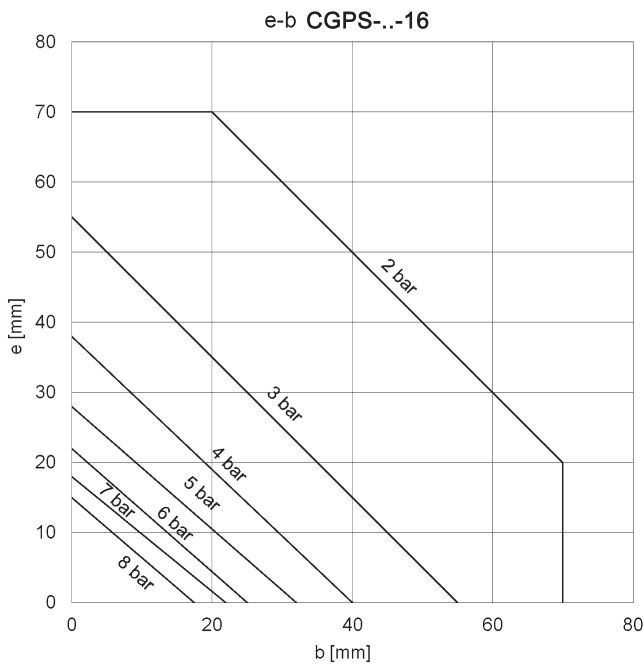

Opening gripping force

b = gripping point (mm)
e = arm (mm)

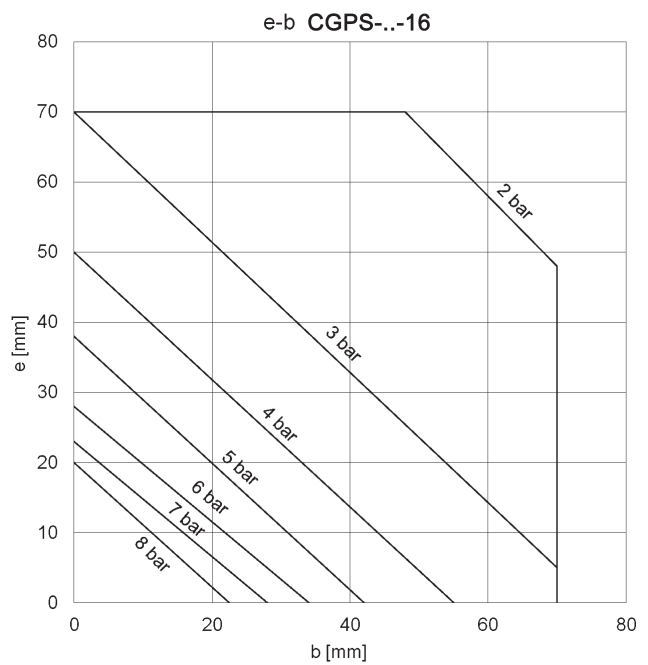

Closing gripping force

b = gripping point (mm)
e = arm (mm)

GRIPPING FORCES Mod. CGPS-...-20

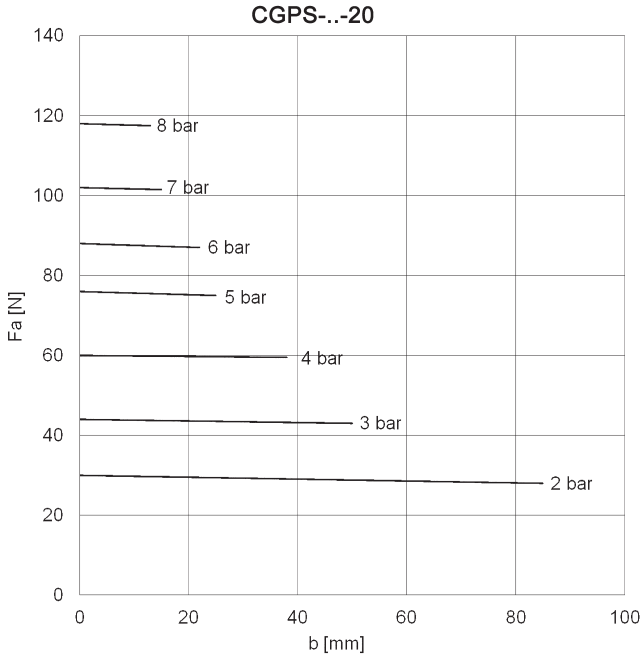

b = gripping point (mm)
Fa = opening gripping force (N)

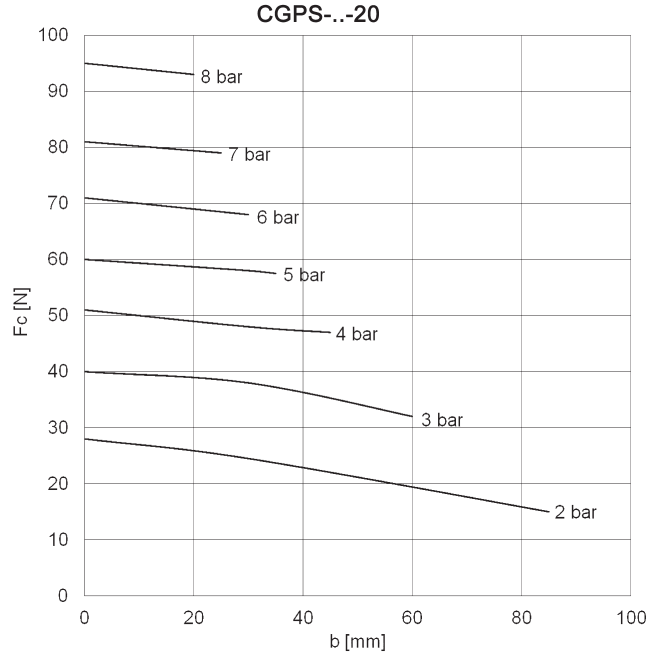

b = gripping point (mm)
Fc = closing gripping force (N)

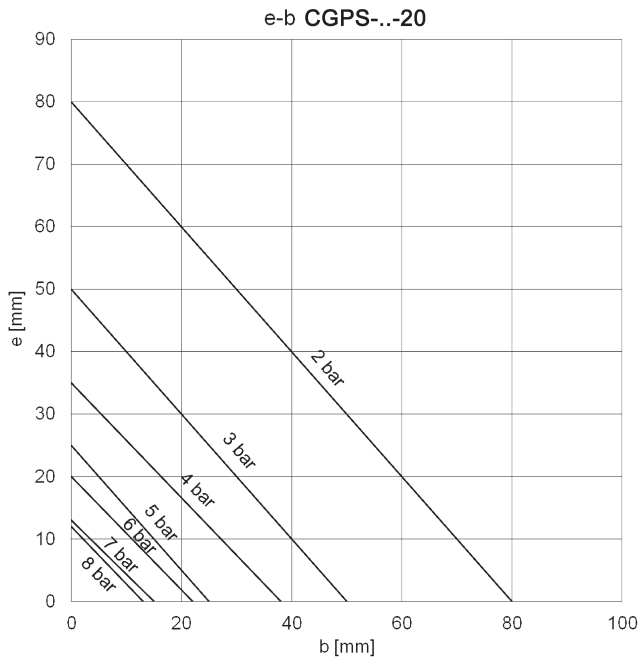

Opening gripping force

b = gripping point (mm)
e = arm (mm)

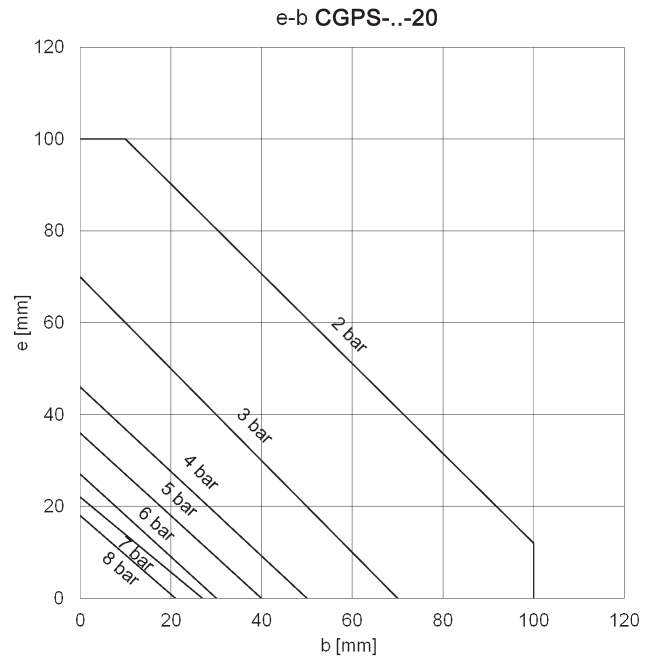

Closing gripping force

b = gripping point (mm)
e = arm (mm)

GRIPPING FORCES Mod. CGPS-...-25

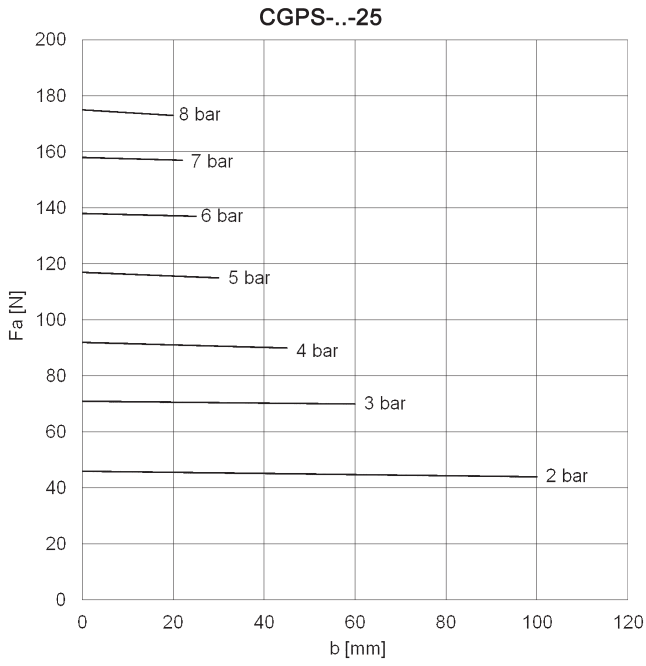

b = gripping point (mm)
Fa = opening gripping force (N)

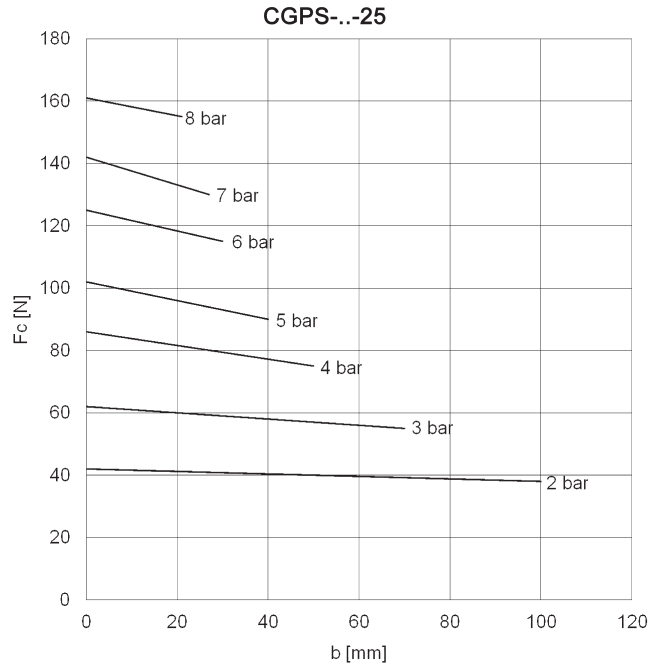

b = gripping point (mm)
Fc = closing gripping force (N)

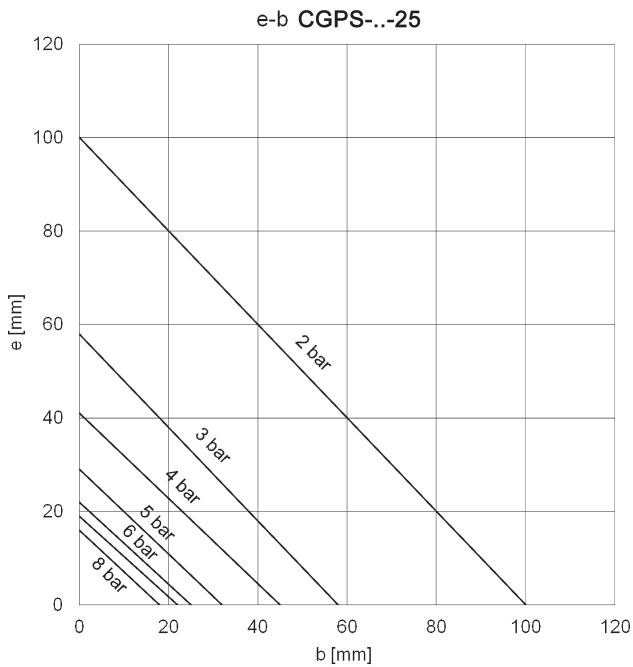

Opening gripping force

b = gripping point (mm)
e = arm (mm)

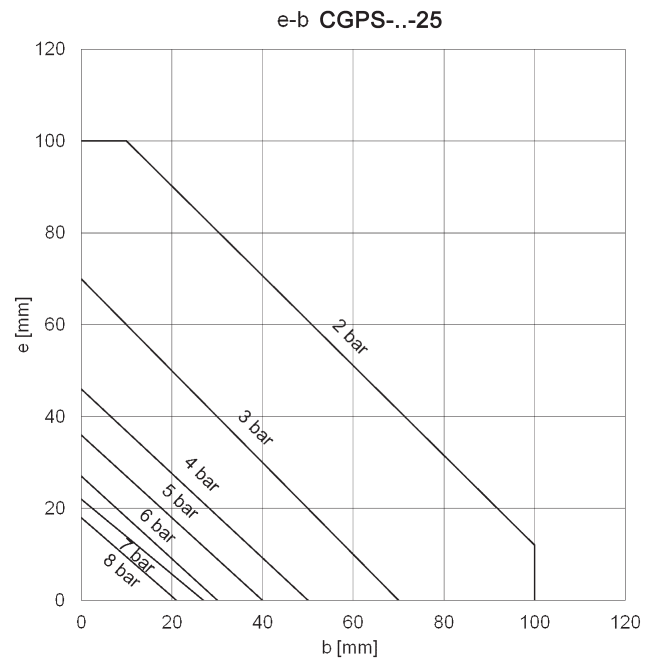

Closing gripping force

b = gripping point (mm)
e = arm (mm)

GRIPPING FORCES Mod. CGPS-...-32

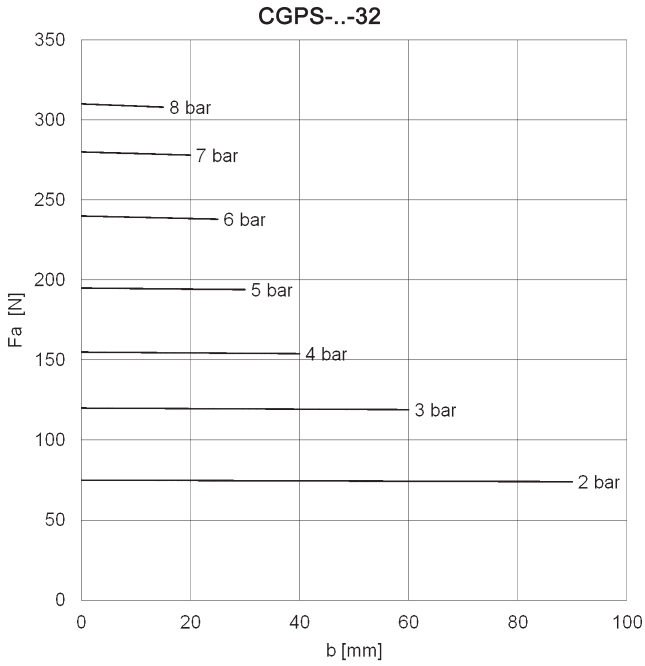

b = gripping point (mm)
Fa = opening gripping force (N)

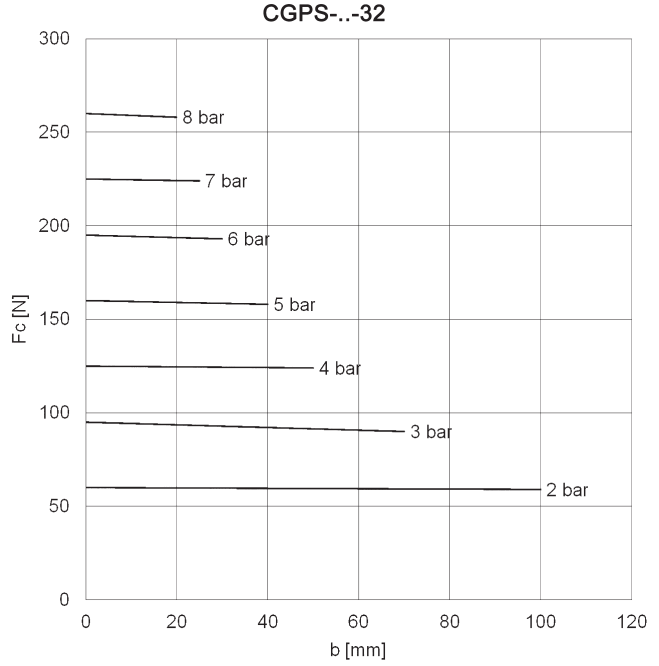

b = gripping point (mm)
Fc = closing gripping force (N)

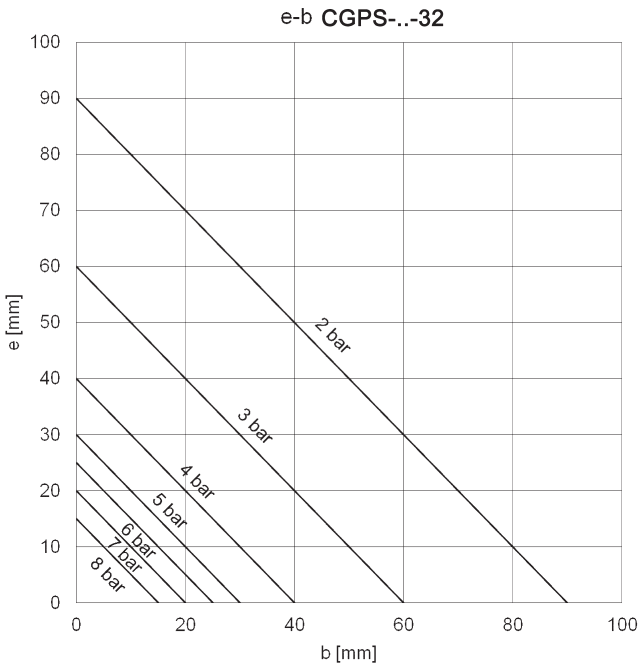

Opening gripping force

b = gripping point (mm)
e = arm (mm)

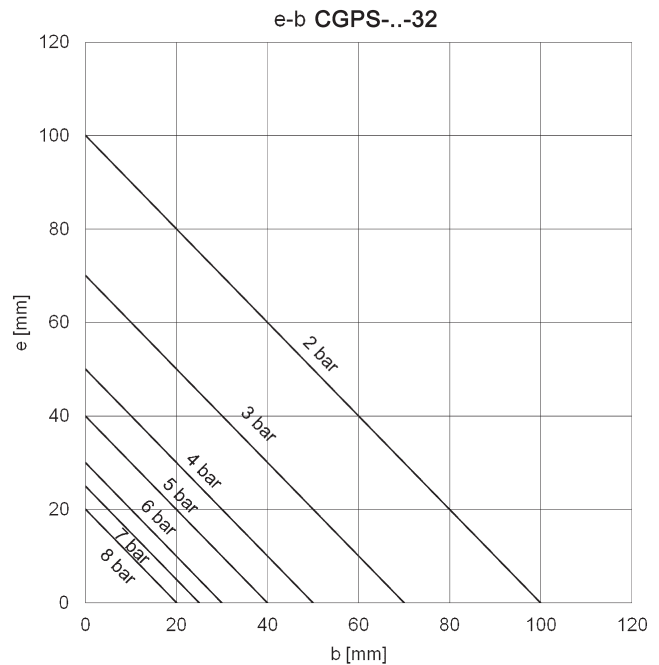

Closing gripping force

b = gripping point (mm)
e = arm (mm)

Examples of mounting

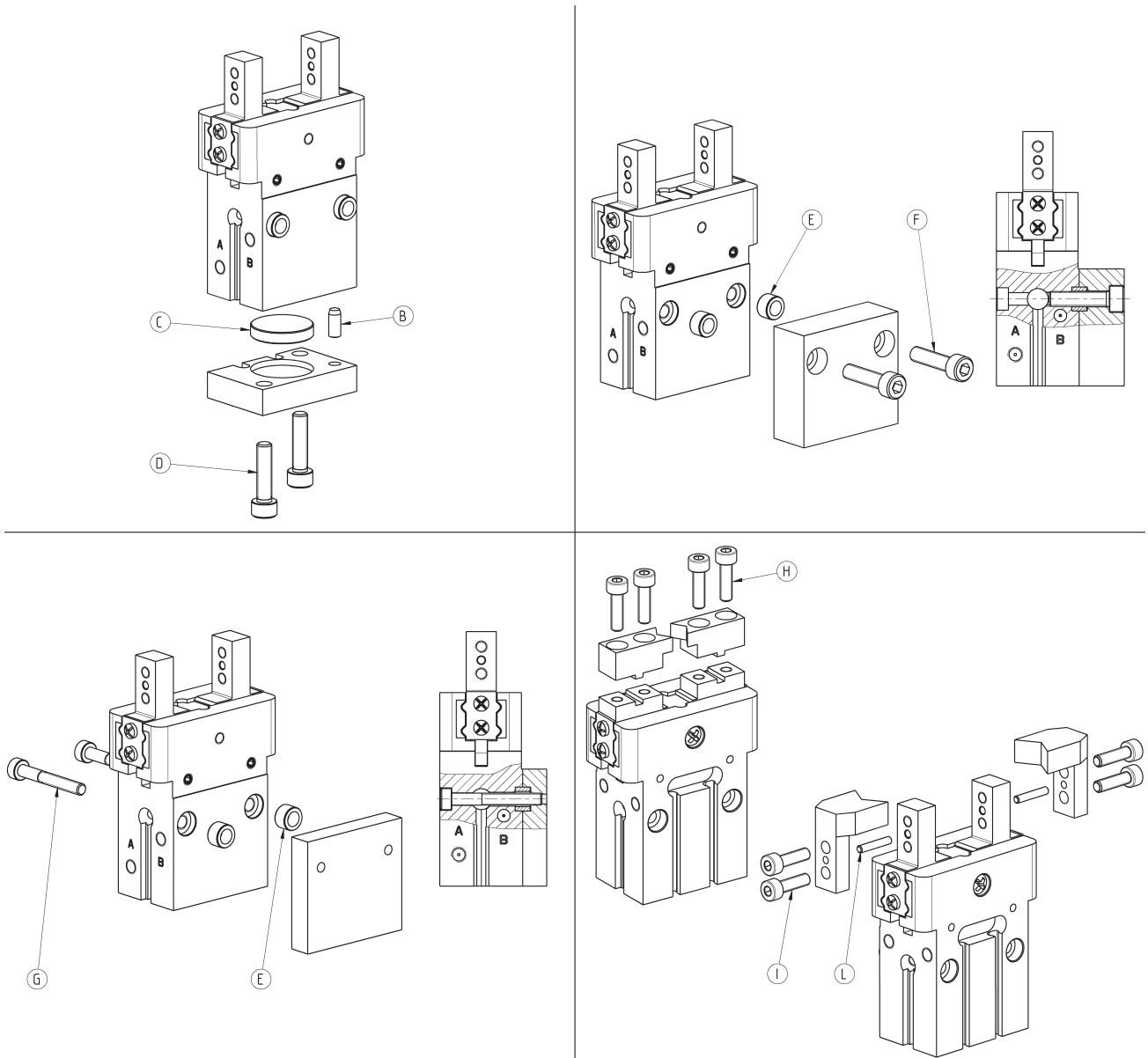

Mod.	B	C	D	E	Centering ring	F	G	H	I	L
CGPS-...-10	Ø2	Ø11	M3	Ø5	TR-CG-05	M3	M2.5	M2.5	M2.5	Ø1.5
CGPS-...-16	Ø3	Ø17	M4	Ø6	TR-CG-06	M4	M3	M3	M3	Ø2
CGPS-...-20	Ø4	Ø21	M5	Ø8	TR-CG-08	M5	M4	M4	M4	Ø2.5
CGPS-...-25	Ø4	Ø26	M6	Ø10	TR-CG-10	M6	M5	M5	M5	Ø3
CGPS-...-32	Ø5	Ø34	M6	Ø10	TR-CG-10	M6	M5	M6	M6	Ø4

Centering ring Mod. TR-CG



Supplied with:
2x centering rings in steel

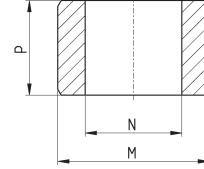
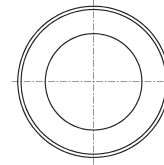

Mod.	M (h8)	N	P
TR-CG-04	Ø4	Ø2.6	2.5
TR-CG-05	Ø5	Ø3.1	3
TR-CG-06	Ø6	Ø4.1	4
TR-CG-08	Ø8	Ø5.1	5
TR-CG-10	Ø10	Ø6.1	6

Air supply ports

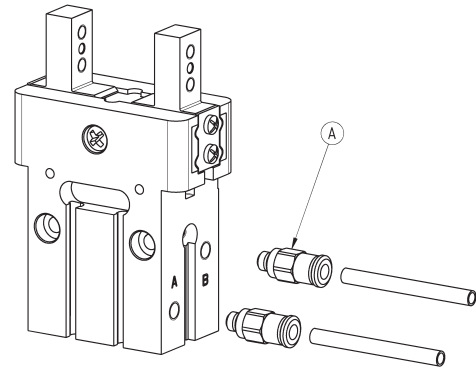

Mod.	A
CGPS--10	M3
CGPS--16	M5
CGPS--20	M5
CGPS--25	M5
CGPS--32	M5

Example of mounting: sensors

Z = sensor mod. CSD-D-334 or mod. CSD-D-364

In order to position the sensor correctly, a channel must be created in the base.

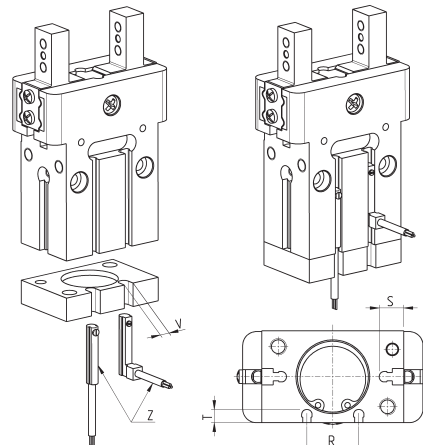

Mod.	R	S	T	V
CGPS--10	-	4.6	-	5
CGPS--16	11	4.8	3.8	5
CGPS--20	15	7	4.6	5
CGPS--25	19	9	4.8	5
CGPS--32	26	9	4.8	5

Mounting shaft Mod. C-CGPS

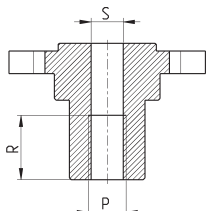
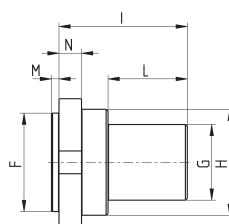
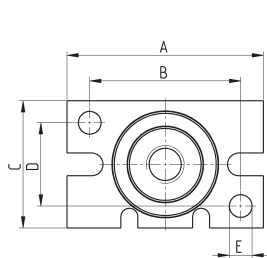

Supplied with:
1x aluminium shaft
2x steel fixing screws

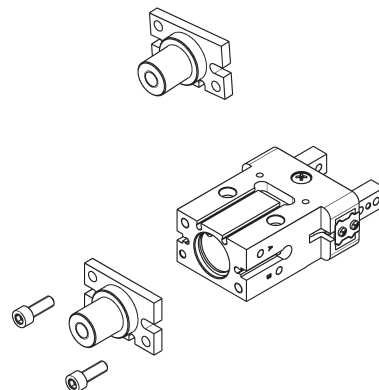

Mod.	A	B	C	D	E	F	G	H	I	L	M	N	P	R	S
C-CGPS-10	23	18	16.4	12	Ø3	Ø11	Ø10	Ø12.8	18.5	11	1.5	3.5	M6	10	Ø5
C-CGPS-16	31	22	23.6	15	Ø4	Ø17	Ø14	Ø17.8	25	16	1.5	4	M8	13	Ø6.8
C-CGPS-20	42	32	27.6	18	Ø5	Ø21	Ø20	Ø22	32	21	2	5	M10	17	Ø8.5
C-CGPS-25	52	40	33.6	22	Ø6	Ø26	Ø20	Ø28	34	21	2	6	M10	17	Ø8.5
C-CGPS-32	60	46	40	26	Ø6	Ø34	Ø30	Ø37	45	31	2	7	M16	25	Ø14

Extension for mounting shaft Mod. L-CGPS

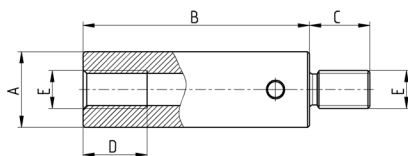

Supplied with:
1x aluminium extension

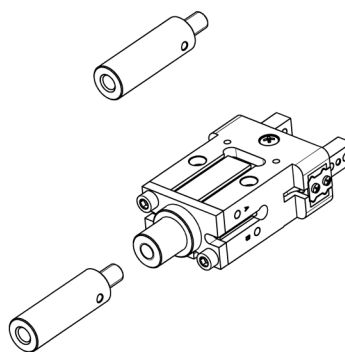

Mod.	A	B	C	D	E
L-CGPS-10	Ø10	40	9	10	M6
L-CGPS-16	Ø14	60	12	13	M8
L-CGPS-20/25	Ø20	60	16	17	M10
L-CGPS-32	Ø30	70	24	25	M16

Series CSD magnetic proximity switches, 3-wire cable, D-slot

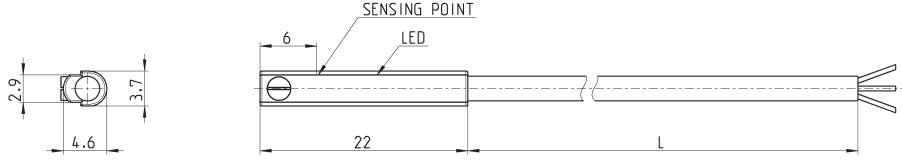
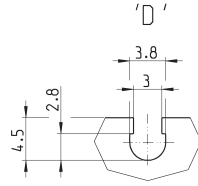

Mod.	Operation	Connections	Voltage	Output	Max. current	Max Load	Protection	L = length cable
CSD-D-334	Magnetoresistive	3 wires	10 ÷ 27 V DC	PNP	200 mA	6W	Against polarity reversing and overvoltage	2 m

Series CSD magnetic switches, male M8 3-pin conn., D-slot, right

Length of cable 0.3 metres

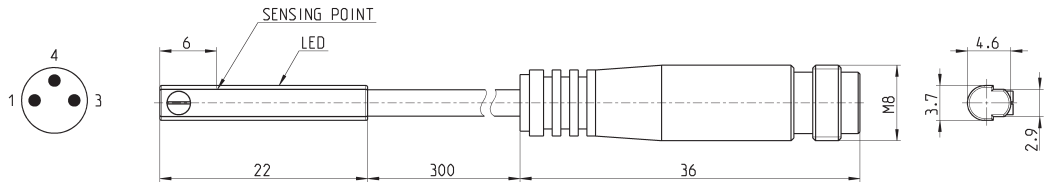
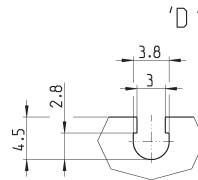

Mod.	Operation	Connection	Voltage	Output	Max. current	Max load	Protection
CSD-D-364	Magnetoresistive	3 wires with M8 connector	10 ÷ 27 V DC	PNP	200 mA	6W	Against polarity reversing and overvoltage