



Series KL - KLE directly operated solenoid valves

2/2-way - Normally Closed (NC)

3/2-way - Normally Closed (NC) and Normally Open (NO)

3/2-way - Universal (UNI)



The new Series KL and KLE 10 mm solenoid valves offer a range with improved models and performance compared to the previous generation.

The possibility to use a longer coil allowed to increase the pressure values to which the valves can be submitted.

- » Application sectors:
 - Life Science
 - Industrial Automation
- » Compact design
- » High flow in proportion to the size
- » Extended version for higher performance
- » M8 - 3 pin electric connection available
- » Monostable and bistable manual override

SERIES KL - KLE SOLENOID VALVE

GENERAL DATA

TECHNICAL FEATURES

Function	2/2 NC - 3/2 NC - 3/2 NO - 3/2 UNI
Operation	direct acting poppet type
Pneumatic connections	on subbase
Orifice diameter	0.6 ... 1.6 mm
Flow coefficient kv (l/min)	0.12 ... 0.50
Operating pressure	0 ÷ 3 ... 9 bar
Operating temperature	0 ÷ 50 °C
Media	filtered compressed air, unlubricated, according to ISO 8573-1 class 3.4.3, inert gas
Response time	ON <10 ms - OFF <10 ms
Manual override	monostable or bistable - only for 3/2 versions
Installation	in any position

MATERIALS IN CONTACT WITH THE MEDIUM

Body	PBT
Seals	FKM
Internal parts	stainless steel - brass

ELECTRICAL FEATURES

Voltage	6 ... 24 V DC - other voltages on demand
Voltage tolerance	±10%
Power consumption	1 W - 1.3/0.3 W - 4/1 W
Duty cycle	ED 100%
Electrical connection	connector mod. 121-8... - M8 connector mod. CS... (the M8 connection of the valve accepts polarity reversal)
Protection class	IP50 with connector 121-8... - IP65 with M8 connector

CODING EXAMPLE

KL	0	4	0	-	A6	3	A	Y	-	1	3	M
-----------	----------	----------	----------	----------	-----------	----------	----------	----------	----------	----------	----------	----------

KL	SERIES KL = standard KLE = extended
0	BODY DESIGN 0 = 3/2 body - ISO 15218 A = 3/2 body - ISO 15218 - coil rotated by 180° 2 = 2/2 body C = 2/2 body - coil rotated by 180°
4	NUMBER OF WAYS - FUNCTIONS 1 = 2/2-way NC 4 = 3/2-way NC 5 = 3/2-way NO 6 = 3/2-way UNI
0	PORTS 0 = on subbase or manifold
A6	ORIFICE DIAMETER A6 = Ø 0.60 mm A8 = Ø 0.80 mm B1 = Ø 1.10 mm B2 = Ø 1.20 mm B3 = Ø 1.30 mm B6 = Ø 1.60 mm
3	SEAL MATERIAL 3 = FKM
A	BODY MATERIAL A = PBT
Y	MANUAL OVERRIDE 0 = not requested or not foreseen Y = monostable B = bistable
1	ELECTRICAL CONNECTION 1 = 90° connection with protection and led B = in-line connection with protection and led M = M8 - 3 pin connection
3	VOLTAGE - POWER CONSUMPTION 1 = 6 V DC - 1 W 2 = 12 V DC - 1 W 3 = 24 V DC - 1 W A = 6 V DC - 1.3/0.3 W B = 12 V DC - 1.3/0.3 W C = 24 V DC - 1.3/0.3 W 5 = 5 V DC - 4/1 W 6 = 6 V DC - 4/1 W 7 = 12 V DC - 4/1 W 8 = 24 V DC - 4/1 W
M	FIXING M = fixing screws for metal P = fixing screws for plastic
	OPTIONS = standard OX1 = for use with oxygen (non volatile residual less than 550 mg/m ²)

SERIES KL - KLE SOLENOID VALVE

Series KL solenoid valve - 2/2-way NC - 90° connector



Supplied with:
1x interface seal
2x M2x16 screws for mounting on metal

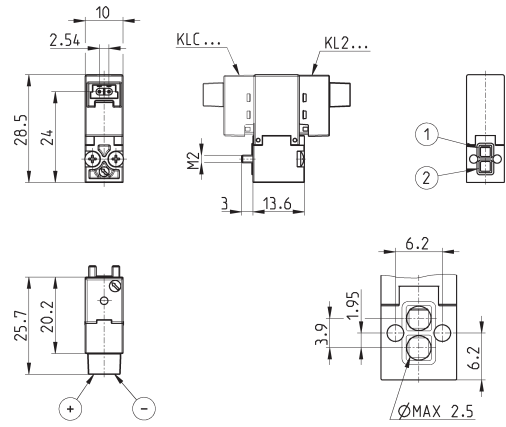

Mod.	Function	Orifice Ø (mm)	kv (l/min)	Pressure min ÷ max (bar)	Power (W)
KL210-A83A0-1°M	2/2 NC	0.8	0.25	0 ÷ 3	1.3 / 0.3
KL210-B23A0-1°M	2/2 NC	1.2	0.40	0 ÷ 6	4 / 1
KL210-B63A0-1°M	2/2 NC	1.6	0.50	0 ÷ 4	4 / 1
KLC10-A83A0-1°M	2/2 NC	0.8	0.25	0 ÷ 3	1.3 / 0.3
KLC10-B23A0-1°M	2/2 NC	1.2	0.40	0 ÷ 6	4 / 1
KLC10-B63A0-1°M	2/2 NC	1.6	0.50	0 ÷ 4	4 / 1

* add
- VOLTAGE
(see CODING EXAMPLE)



Series KL solenoid valve - 2/2-way NC - in-line connector



Supplied with:
1x interface seal
2x M2x16 screws for mounting on metal

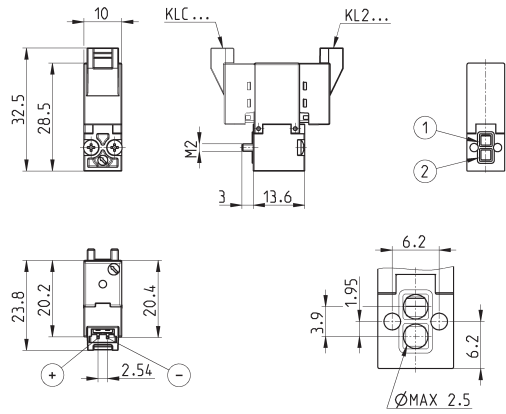

Mod.	Function	Orifice Ø (mm)	kv (l/min)	Pressure min ÷ max (bar)	Power (W)
KL210-A83A0-B°M	2/2 NC	0.8	0.25	0 ÷ 3	1.3 / 0.3
KL210-B23A0-B°M	2/2 NC	1.2	0.40	0 ÷ 6	4 / 1
KL210-B63A0-B°M	2/2 NC	1.6	0.50	0 ÷ 4	4 / 1
KLC10-A83A0-B°M	2/2 NC	0.8	0.25	0 ÷ 3	1.3 / 0.3
KLC10-B23A0-B°M	2/2 NC	1.2	0.40	0 ÷ 6	4 / 1
KLC10-B63A0-B°M	2/2 NC	1.6	0.50	0 ÷ 4	4 / 1

* add
- VOLTAGE
(see CODING EXAMPLE)



Series KLE solenoid valve - 2/2-way NC - 90° connector



Supplied with:
1x interface seal
2x M2x16 screws for mounting on metal

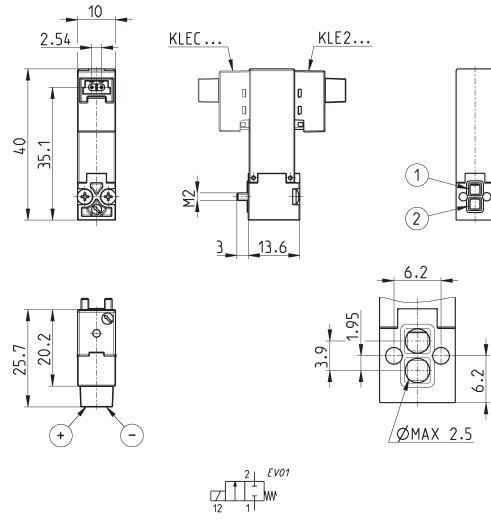

Mod.	Function	Orifice Ø (mm)	kv (l/min)	Pressure min ÷ max (bar)	Power (W)
KLE210-A83A0-1*M	2/2 NC	0.8	0.25	0 ÷ 5	1
KLE210-B23A0-1*M	2/2 NC	1.2	0.40	0 ÷ 8	4 / 1
KLE210-B63A0-1*M	2/2 NC	1.6	0.50	0 ÷ 6	4 / 1
KLEC10-A83A0-1*M	2/2 NC	0.8	0.25	0 ÷ 5	1
KLEC10-B23A0-1*M	2/2 NC	1.2	0.40	0 ÷ 8	4 / 1
KLEC10-B63A0-1*M	2/2 NC	1.6	0.50	0 ÷ 6	4 / 1

* add
- VOLTAGE
(see CODING EXAMPLE)

Series KLE solenoid valve - 2/2-way NC - in-line connector



Supplied with:
1x interface seal
2x M2x16 screws for mounting on metal

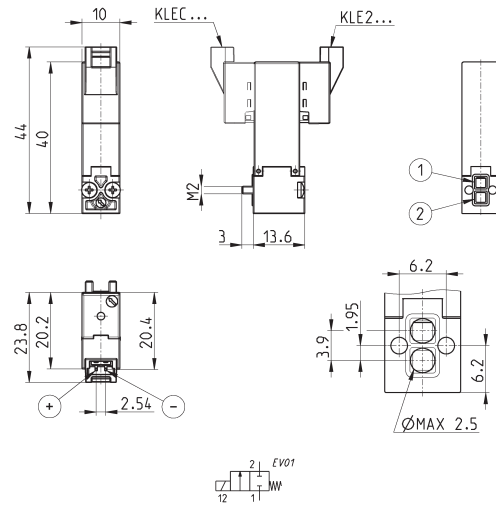

Mod.	Function	Orifice Ø (mm)	kv (l/min)	Pressure min ÷ max (bar)	Power (W)
KLE210-A83A0-B*M	2/2 NC	0.8	0.25	0 ÷ 5	1
KLE210-B23A0-B*M	2/2 NC	1.2	0.40	0 ÷ 8	4 / 1
KLE210-B63A0-B*M	2/2 NC	1.6	0.50	0 ÷ 6	4 / 1
KLEC10-A83A0-B*M	2/2 NC	0.8	0.25	0 ÷ 5	1
KLEC10-B23A0-B*M	2/2 NC	1.2	0.40	0 ÷ 8	4 / 1
KLEC10-B63A0-B*M	2/2 NC	1.6	0.50	0 ÷ 6	4 / 1

* add
- VOLTAGE
(see CODING EXAMPLE)

Series KLE solenoid valve - 2/2-way NC - M8 connector



Supplied with:
1x interface seal
2x M2x16 screws for mounting on metal

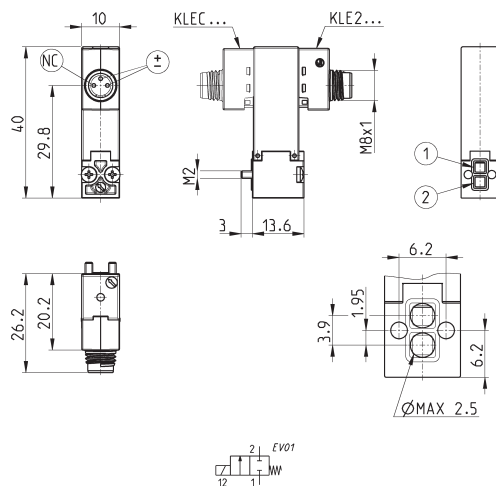

Mod.	Function	Orifice Ø (mm)	kv (l/min)	Pressure min ÷ max (bar)	Power (W)
KLE210-A83A0-M*M	2/2 NC	0.8	0.25	0 ÷ 5	1
KLEC10-A83A0-M*M	2/2 NC	0.8	0.25	0 ÷ 5	1

* add
- VOLTAGE
(see CODING EXAMPLE)

Series KL solenoid valve - 3/2-way - 90° connector



Supplied with:
 1x interface seal
 2x M1.6x14.7 screws for mounting on metal
 or
 2x Ø1.6x16 screws for mounting on plastic
 3/2 UNI models can work with vacuum. The maximum pressure will be reduced by 1 bar.

Mod.	Function	Orifice Ø (mm)	kv (l/min)	Pressure min ÷ max (bar)	Power (W)
KL ⁴⁰ -A63A [*] -1 ^{**}	3/2 NC	0.6	0.12	0 ÷ 7	1
KL ⁴⁰ -A83A [*] -1 ^{**}	3/2 NC	0.8	0.18	0 ÷ 5	1
KL ⁴⁰ -B13A [*] -1 ^{**}	3/2 NC	1.1	0.32	3 ÷ 7	4 / 1
KL ⁴⁰ -B33A [*] -1 ^{**}	3/2 NC	1.3	0.37	0 ÷ 3	4 / 1
KL ⁵⁰ -A63A [*] -1 ^{**}	3/2 NO	0.6	0.12	0 ÷ 7	1.3 / 0.3
KL ⁵⁰ -A83A [*] -1 ^{**}	3/2 NO	0.8	0.18	0 ÷ 5	1.3 / 0.3
KL ⁵⁰ -B13A [*] -1 ^{**}	3/2 NO	1.0	0.30	0 ÷ 5	4 / 1
KL ⁵⁰ -B33A [*] -1 ^{**}	3/2 NO	1.3	0.37	0 ÷ 3	4 / 1
KL ⁶⁰ -A63A [*] -1 ^{**}	3/2 UNI	0.6	0.12	0 ÷ 5 [-1 ÷ 4]	1.3 / 0.3
KL ⁶⁰ -A83A [*] -1 ^{**}	3/2 UNI	0.8	0.18	0 ÷ 2 [-1 ÷ 1]	1.3 / 0.3
KL ⁶⁰ -B13A [*] -1 ^{**}	3/2 UNI	1.1	0.30	0 ÷ 3 [-1 ÷ 2]	4 / 1
KL ⁶⁰ -B33A [*] -1 ^{**}	3/2 UNI	1.3	0.37	0 ÷ 2 [-1 ÷ 1]	4 / 1

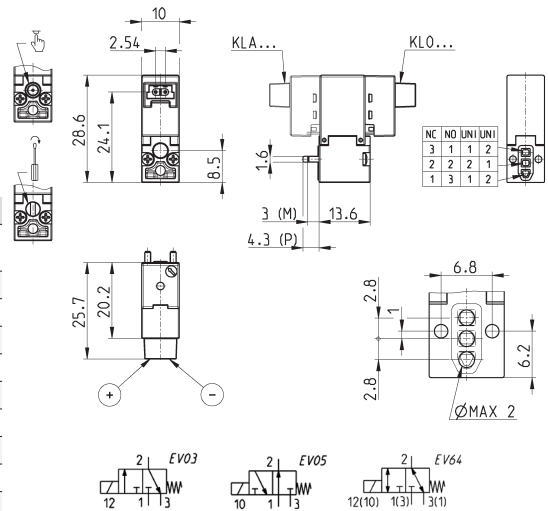

* add
 - BODY DESIGN
 - MANUAL OVERRIDE
 - VOLTAGE
 - FIXING
 (see CODING EXAMPLE)

Series KL solenoid valve - 3/2-way - in-line connector



Supplied with:
 1x interface seal
 2x M1.6x14.7 screws for mounting on metal
 or
 2x Ø1.6x16 screws for mounting on plastic
 3/2 UNI models can work with vacuum. The maximum pressure will be reduced by 1 bar.

Mod.	Function	Orifice Ø (mm)	kv (l/min)	Pressure min ÷ max (bar)	Power (W)
KL ⁴⁰ -A63A [*] -B ^{**}	3/2 NC	0.6	0.12	0 ÷ 7	1
KL ⁴⁰ -A83A [*] -B ^{**}	3/2 NC	0.8	0.18	0 ÷ 5	1
KL ⁴⁰ -B13A [*] -B ^{**}	3/2 NC	1.1	0.32	3 ÷ 7	4 / 1
KL ⁴⁰ -B33A [*] -B ^{**}	3/2 NC	1.3	0.37	0 ÷ 3	4 / 1
KL ⁵⁰ -A63A [*] -B ^{**}	3/2 NO	0.6	0.12	0 ÷ 7	1.3 / 0.3
KL ⁵⁰ -A83A [*] -B ^{**}	3/2 NO	0.8	0.18	0 ÷ 5	1.3 / 0.3
KL ⁵⁰ -B13A [*] -B ^{**}	3/2 NO	1.0	0.30	0 ÷ 5	4 / 1
KL ⁵⁰ -B33A [*] -B ^{**}	3/2 NO	1.3	0.37	0 ÷ 3	4 / 1
KL ⁶⁰ -A63A [*] -B ^{**}	3/2 UNI	0.6	0.12	0 ÷ 5 [-1 ÷ 4]	1.3 / 0.3
KL ⁶⁰ -A83A [*] -B ^{**}	3/2 UNI	0.8	0.18	0 ÷ 2 [-1 ÷ 1]	1.3 / 0.3
KL ⁶⁰ -B13A [*] -B ^{**}	3/2 UNI	1.1	0.30	0 ÷ 3 [-1 ÷ 2]	4 / 1
KL ⁶⁰ -B33A [*] -B ^{**}	3/2 UNI	1.3	0.37	0 ÷ 2 [-1 ÷ 1]	4 / 1

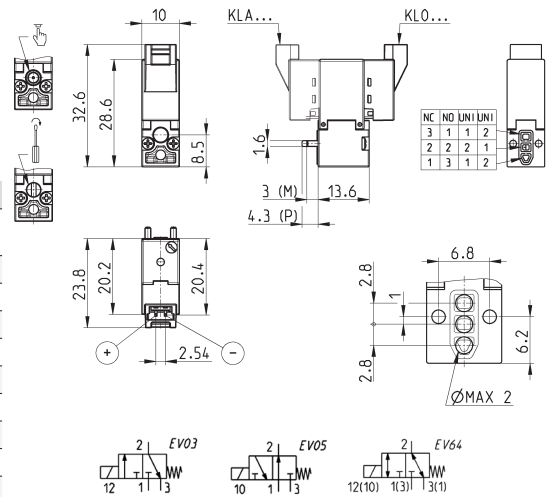

* add
 - BODY DESIGN
 - MANUAL OVERRIDE
 - VOLTAGE
 - FIXING
 (see CODING EXAMPLE)

Series KL solenoid valve - 3/2-way - M8 connector



Supplied with:
 1x interface seal
 2x M1.6x14.7 screws for mounting on metal
 or
 2x Ø1.6x16 screws for mounting on plastic

Mod.	Function	Orifice Ø (mm)	kv (l/min)	Pressure min ÷ max (bar)	Power (W)
KL ⁴⁰ -A63A [*] -M ^{**}	3/2 NC	0.6	0.12	0 ÷ 7	1
KL ⁴⁰ -A83A [*] -M ^{**}	3/2 NC	0.8	0.18	0 ÷ 5	1

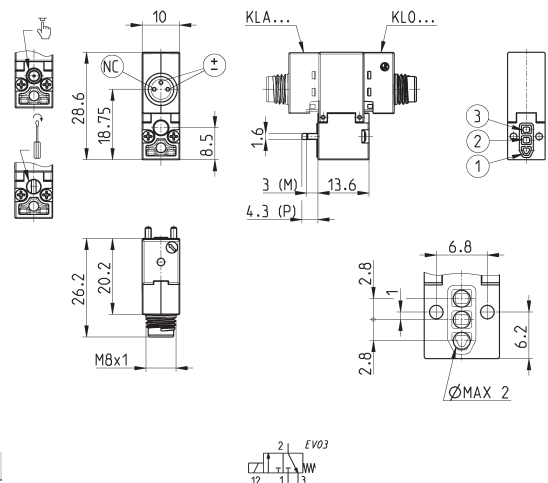

* add
 - BODY DESIGN
 - MANUAL OVERRIDE
 - VOLTAGE
 - FIXING
 (see CODING EXAMPLE)

Series KLE solenoid valve - 3/2-way - 90° connector



Supplied with:
1x interface seal
2x M1.6x14.7 screws for mounting on metal or
2x Ø1.6x16 screws for mounting on plastic
3/2 UNI models can work with vacuum. The maximum pressure will be reduced by 1 bar.

Mod.	Function	Orifice Ø (mm)	kv (l/min)	Pressure min ÷ max (bar)	Power (W)
KLE*40-A63A*-1**	3/2 NC	0.6	0.12	0 ÷ 9	1
KLE*40-A83A*-1**	3/2 NC	0.8	0.18	0 ÷ 7	1
KLE*40-B13A*-1**	3/2 NC	1.1	0.33	0 ÷ 7	4 / 1
KLE*40-B33A*-1**	3/2 NC	1.3	0.37	0 ÷ 4	4 / 1
KLE*50-A63A*-1**	3/2 NO	0.6	0.12	0 ÷ 9	1
KLE*50-A83A*-1**	3/2 NO	0.8	0.18	0 ÷ 7	1
KLE*50-B13A*-1**	3/2 NO	1.0	0.30	0 ÷ 7	4 / 1
KLE*50-B33A*-1**	3/2 NO	1.3	0.37	0 ÷ 4	4 / 1
KLE*60-A63A*-1**	3/2 UNI	0.6	0.12	0 ÷ 7 [-1 ÷ 6]	1
KLE*60-A83A*-1**	3/2 UNI	0.8	0.18	0 ÷ 4 [-1 ÷ 3]	1
KLE*60-B13A*-1**	3/2 UNI	1.1	0.30	0 ÷ 4 [-1 ÷ 3]	4 / 1
KLE*60-B33A*-1**	3/2 UNI	1.3	0.37	0 ÷ 3 [-1 ÷ 2]	4 / 1

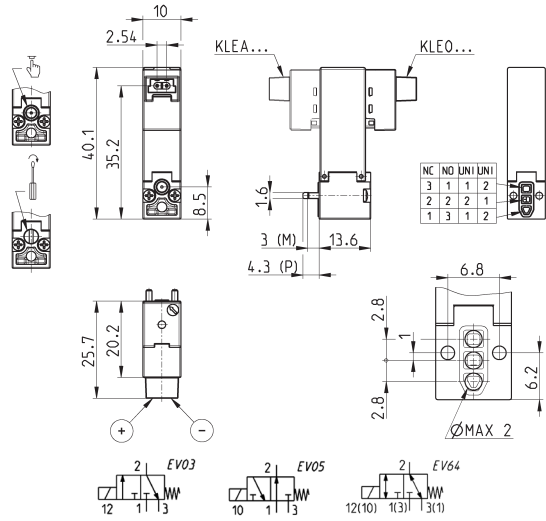

* add
- BODY DESIGN
- MANUAL OVERRIDE
- VOLTAGE
- FIXING
(see CODING EXAMPLE)

Series KLE solenoid valve - 3/2-way - in-line connector



Supplied with:
1x interface seal
2x M1.6x14.7 screws for mounting on metal or
2x Ø1.6x16 screws for mounting on plastic
3/2 UNI models can work with vacuum. The maximum pressure will be reduced by 1 bar.

Mod.	Function	Orifice Ø (mm)	kv (l/min)	Pressure min ÷ max (bar)	Power (W)
KLE*40-A63A*-B**	3/2 NC	0.6	0.12	0 ÷ 9	1
KLE*40-A83A*-B**	3/2 NC	0.8	0.18	0 ÷ 7	1
KLE*40-B13A*-B**	3/2 NC	1.1	0.33	0 ÷ 7	4 / 1
KLE*40-B33A*-B**	3/2 NC	1.3	0.37	0 ÷ 4	4 / 1
KLE*50-A63A*-B**	3/2 NO	0.6	0.12	0 ÷ 9	1
KLE*50-A83A*-B**	3/2 NO	0.8	0.18	0 ÷ 7	1
KLE*50-B13A*-B**	3/2 NO	1.0	0.30	0 ÷ 7	4 / 1
KLE*50-B33A*-B**	3/2 NO	1.3	0.37	0 ÷ 4	4 / 1
KLE*60-A63A*-B**	3/2 UNI	0.6	0.12	0 ÷ 7 [-1 ÷ 6]	1
KLE*60-A83A*-B**	3/2 UNI	0.8	0.18	0 ÷ 4 [-1 ÷ 3]	1
KLE*60-B13A*-B**	3/2 UNI	1.1	0.30	0 ÷ 4 [-1 ÷ 3]	4 / 1
KLE*60-B33A*-B**	3/2 UNI	1.3	0.37	0 ÷ 3 [-1 ÷ 2]	4 / 1

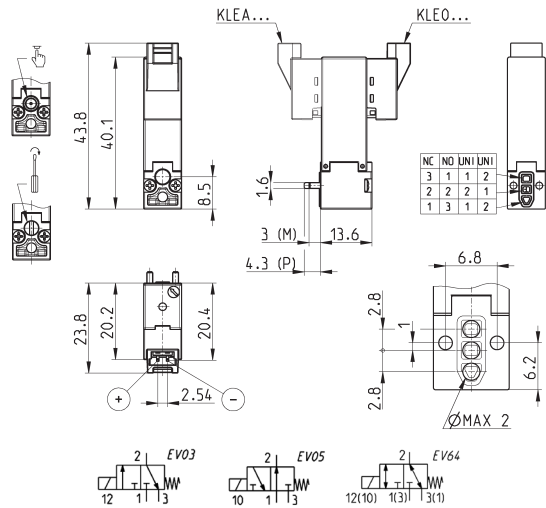

* add
- BODY DESIGN
- MANUAL OVERRIDE
- VOLTAGE
- FIXING
(see CODING EXAMPLE)

Series KLE solenoid valve - 3/2-way - M8 connector



Supplied with:
1x interface seal
2x M1.6x14.7 screws for mounting on metal or
2x Ø1.6x16 screws for mounting on plastic
3/2 UNI models can work with vacuum. The maximum pressure will be reduced by 1 bar.

Mod.	Function	Orifice Ø (mm)	kv (l/min)	Pressure min ÷ max (bar)	Power (W)
KLE*40-A63A*-M**	3/2 NC	0.6	0.12	0 ÷ 9	1
KLE*40-A83A*-M**	3/2 NC	0.8	0.18	0 ÷ 7	1
KLE*50-A63A*-M**	3/2 NO	0.6	0.12	0 ÷ 9	1
KLE*50-A83A*-M**	3/2 NO	0.8	0.18	0 ÷ 7	1
KLE*60-A63A*-M**	3/2 UNI	0.6	0.12	0 ÷ 7 [-1 ÷ 6]	1
KLE*60-A83A*-M**	3/2 UNI	0.8	0.18	0 ÷ 4 [-1 ÷ 3]	1

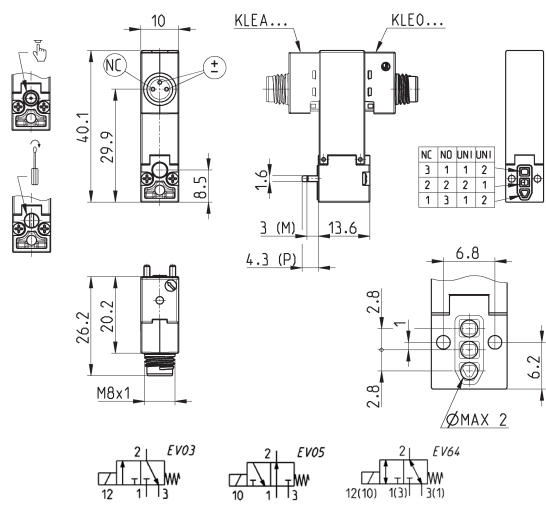

* add
- BODY DESIGN
- MANUAL OVERRIDE
- VOLTAGE
- FIXING
(see CODING EXAMPLE)

Single sub-base for 2-way solenoid valve size 10 mm

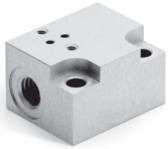

Single sub-base suitable for Series KL 2-way solenoid valve
Use solenoid valves with screws for mounting on metal (see coding)

Material: anodized aluminium
Connections: M5 threads

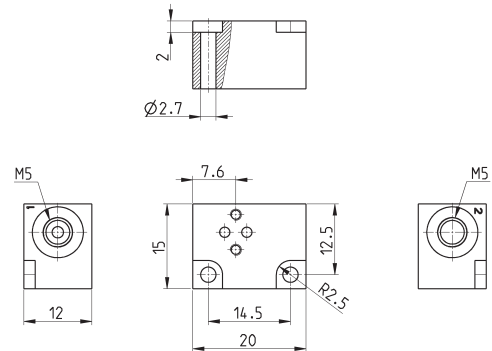

Mod.

KL01-02

Single sub-base for 3-way solenoid valve size 10 mm

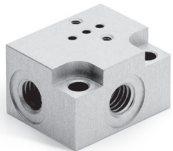

Single sub-base suitable for Series KN - KL - KLE 3-way solenoid valve
Use solenoid valves with screws for mounting on metal (see coding)

Material: anodized aluminium
Connections: M5 threads

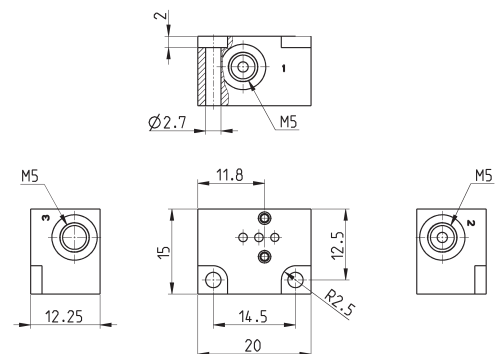

Mod.

KN01-02

Connector with flying leads Mod. 121-8..

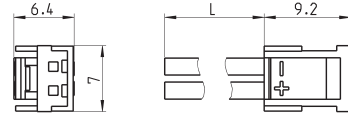

Mod.	description	colour	L = cable length (mm)	cable holding
121-803	crimped cable	black	300	crimping
121-806	crimped cable	black	600	crimping
121-810	crimped cable	black	1000	crimping
121-830	crimped cable	black	3000	crimping

3-wire extension with M8 3-pin female connector



With PU sheathing, non shielded cable.
Protection class: IP65

- 1 BN = Brown
- 4 BK = Black
- 3 BU = Blue

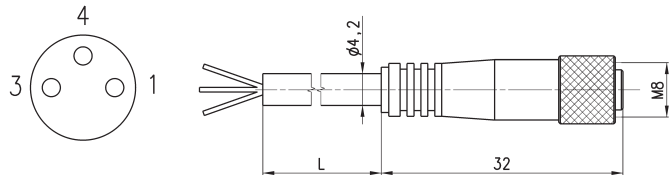

Mod.	L = cable length (m)
CS-2	2
CS-5	5
CS-10	10