

# Series ASP angle seat valves



2/2-way - Normally Closed (NC) and Normally Open (NO)  
2/2-way - Double Acting (DA)



The Series ASP angle seat valves are an efficient and cost-effective solution for fluid control. Their robustness is suitable for the most varied applications with inert gases and liquids, with steam or with fluids having solid particulates in suspension. Available with 3/8" to 2-1/2" threaded connections.

- » Differential pressure up to 20 bar
- » High flow
- » Low resistance of the flow
- » Anti-water hammer design
- » Compliant with Directive PED 2014/68/UE

The operation is determined by the pneumatic drive of a single acting, guided piston actuator with spring return. There are also models available with double acting actuators, without spring. For liquid media we recommend the models with flow direction under the seat. For gas or steam we recommend the models with flow direction above the seat.

## GENERAL DATA

### TECHNICAL FEATURES

Function	2/2 NC - 2/2 NO - 2/2 Double Acting
Operation	pneumatic, poppet type
Pneumatic connections	3/8 ... 2-1/2" with BSP thread (NPT on demand)
Nominal diameter	DN10 ... DN65
Flow coefficient Kv (m <sup>3</sup> /h)	2.6 ... 65
Operating pressure	0 ÷ 6 ... 20 bar
Operating temperature	-20 ÷ 130 °C
Media	water, air, steam, inert liquids and gases (compatible with the materials in contact)
Viscosity	600 cSt. max
Installation	in any position

### MATERIALS IN CONTACT WITH THE MEDIUM

Body	brass
Seals	EPDM
Internal parts	304 stainless steel

### SPECIFICATIONS PNEUMATIC ACTUATOR

Actuator dimensions	Ø50 - Ø63 - Ø80 - Ø100 mm
Actuator material	PA66 polyamide 30% GF
Piston material	aluminium
Piston seal material	PUR
Piloting fluid	air or inert gases
Piloting pressure	10 bar max.
Actuator position	360° rotatable

**CODING EXAMPLE**

<b>AS</b>	<b>P</b>	<b>A</b>	<b>1</b>	<b>-</b>	<b>W</b>	<b>015</b>	<b>G1</b>	<b>-</b>	<b>050</b>	<b>P</b>	<b>2</b>
-----------	----------	----------	----------	----------	----------	------------	-----------	----------	------------	----------	----------

<b>AS</b>	SERIES
<b>P</b>	TYPE OF ACTUATOR P = technopolymer actuator
<b>A</b>	BODY MATERIAL A = brass
<b>1</b>	NUMBER OF WAYS - FUNCTIONS 0 = 2/2-way NO 1 = 2/2-way NC 3 = 2/2-way DA (Double Acting)
<b>W</b>	FLOW DIRECTION W = under the seat (liquids and gases, anti-water hammer) Y = above the seat (gases)
<b>015</b>	NOMINAL DIAMETER 010 = DN 10 015 = DN 15 020 = DN 20 025 = DN 25 032 = DN 32 040 = DN 40 050 = DN 50 065 = DN 65
<b>G1</b>	BODY CONNECTION G1 = BSP thread DIN 228-1 N1 = NPT thread ASME B1.20.1 (on demand)
<b>050</b>	ACTUATOR DIMENSION 050 = Ø50 mm 063 = Ø63 mm 080 = Ø80 mm 100 = Ø100 mm
<b>P</b>	ACTUATOR MATERIAL P = PA66 polyamide 30% GF
<b>2</b>	SEALS 2 = for standard temperatures -20 ÷ 130 °C

SERIES ASP ANGLE SEAT VALVES

**Series ASP angle seat valve - 2/2-way NC - pressure under the seat**



The valves with flow direction under the seat are suitable for incompressible fluids. This function prevents the hydraulic water hammer effect.

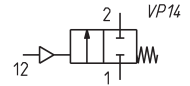

**DRAWING LEGEND:**  
 C = valve in closed position  
 O = valve in open position

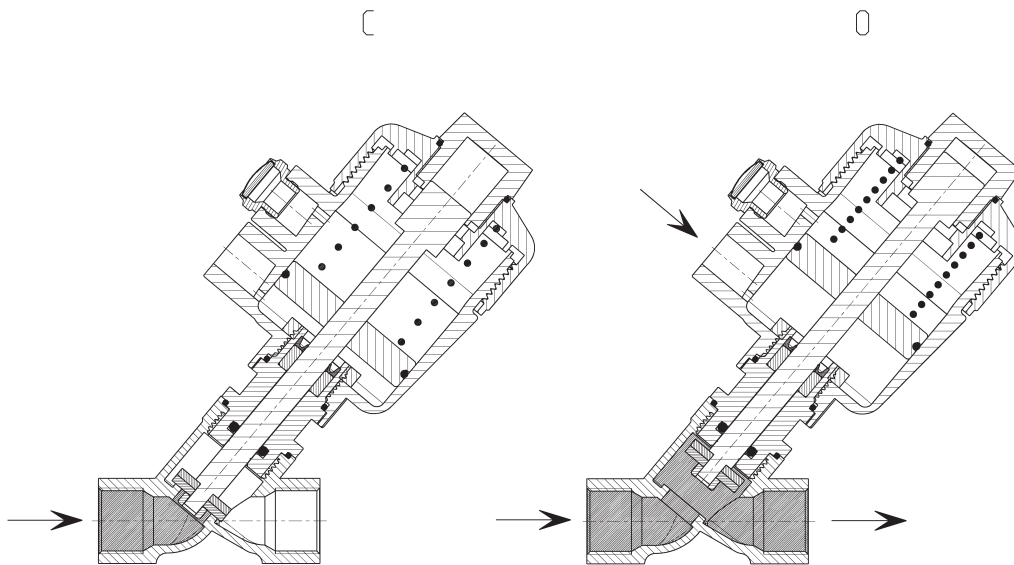

Mod.	Function	DN	Ports	Orifice Ø (mm)	Kv (m³/h)	Differential pressure min + max (bar)	Minimum piloting pressure (bar)	Actuator Ø (mm)	Actuator material
ASPA1-W010G1-050P2	2/2 NC	10	G3/8"	12	2.6	0 ÷ 20	≥ 6	50	PA66
ASPA1-W015G1-050P2	2/2 NC	15	G1/2"	12	3.5	0 ÷ 18	≥ 6	50	PA66
ASPA1-W015G1-063P2	2/2 NC	15	G1/2"	12	3.5	0 ÷ 20	≥ 6	63	PA66
ASPA1-W020G1-050P2	2/2 NC	20	G3/4"	17	8.6	0 ÷ 14	≥ 6	50	PA66
ASPA1-W020G1-063P2	2/2 NC	20	G3/4"	17	8.6	0 ÷ 18	≥ 6	63	PA66
ASPA1-W025G1-050P2	2/2 NC	25	G1"	21	9.7	0 ÷ 9	≥ 6	50	PA66
ASPA1-W025G1-063P2	2/2 NC	25	G1"	21	9.7	0 ÷ 14	≥ 6	63	PA66
ASPA1-W032G1-063P2	2/2 NC	32	G1 1/4"	30	26.7	0 ÷ 10	≥ 6	63	PA66
ASPA1-W032G1-080P2	2/2 NC	32	G1 1/4"	30	26.7	0 ÷ 16	≥ 6	80	PA66
ASPA1-W040G1-080P2	2/2 NC	40	G1 1/2"	37	40.4	0 ÷ 11	≥ 6	80	PA66
ASPA1-W040G1-100P2	2/2 NC	40	G1 1/2"	37	40.4	0 ÷ 20	≥ 6	100	PA66
ASPA1-W050G1-080P2	2/2 NC	50	G2"	46	55	0 ÷ 6	≥ 6	80	PA66
ASPA1-W050G1-100P2	2/2 NC	50	G2"	46	55	0 ÷ 12	≥ 6	100	PA66
ASPA1-W065G1-100P2	2/2 NC	65	2 1/2"	59	65	0 ÷ 6	≥ 6	100	PA66

**Series ASP angle seat valve - 2/2-way NC - pressure above the seat**



The valves with flow direction above the seat are suitable for compressible fluids.

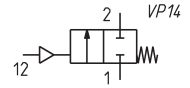

**DRAWING LEGEND:**  
C = valve in closed position  
O = valve in open position

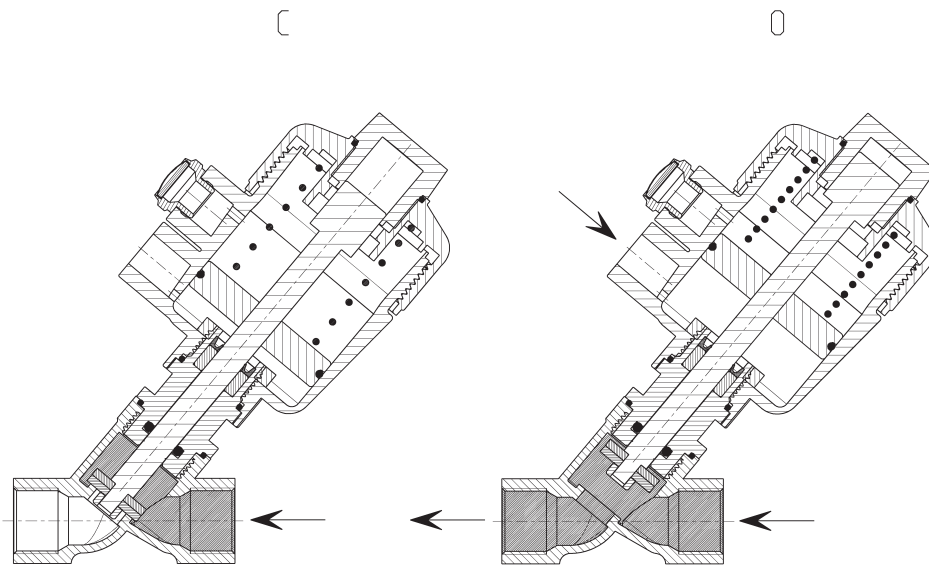

Mod.	Function	DN	Ports	Orifice Ø (mm)	Kv (m <sup>3</sup> /h)	Differential pressure min ÷ max (bar)	Minimum piloting pressure (bar)	Actuator Ø(mm)	Actuator material
ASPA1-Y010G1-050P2	2/2 NC	10	G3/8"	12	2.6	0 ÷ 20	≥ 6	50	PA66
ASPA1-Y015G1-050P2	2/2 NC	15	G1/2"	12	3.5	0 ÷ 20	≥ 6	50	PA66
ASPA1-Y015G1-063P2	2/2 NC	15	G1/2"	12	3.5	0 ÷ 20	≥ 6	63	PA66
ASPA1-Y020G1-050P2	2/2 NC	20	G3/4"	17	8.6	0 ÷ 20	≥ 6	50	PA66
ASPA1-Y020G1-063P2	2/2 NC	20	G3/4"	17	8.6	0 ÷ 20	≥ 6	63	PA66
ASPA1-Y025G1-050P2	2/2 NC	25	G1"	21	9.7	0 ÷ 20	6 ÷ 8.8	50	PA66
ASPA1-Y025G1-063P2	2/2 NC	25	G1"	21	9.7	0 ÷ 20	≥ 6	63	PA66
ASPA1-Y032G1-063P2	2/2 NC	32	G1 1/4"	30	26.7	0 ÷ 20	6 ÷ 8	63	PA66
ASPA1-Y032G1-080P2	2/2 NC	32	G1 1/4"	30	26.7	0 ÷ 20	6 ÷ 7.5	80	PA66
ASPA1-Y040G1-080P2	2/2 NC	40	G1 1/2"	37	40.4	0 ÷ 20	6 ÷ 9	80	PA66
ASPA1-Y040G1-100P2	2/2 NC	40	G1 1/2"	37	40.4	0 ÷ 20	6 ÷ 6.7	100	PA66
ASPA1-Y050G1-080P2	2/2 NC	50	G2"	46	55	0 ÷ 14	6 ÷ 10	80	PA66
ASPA1-Y050G1-100P2	2/2 NC	50	G2"	46	55	0 ÷ 20	6 ÷ 7.8	100	PA66
ASPA1-Y065G1-100P2	2/2 NC	65	2 1/2"	59	65	0 ÷ 16	6 ÷ 8.2	100	PA66

**Series ASP angle seat valve - 2/2-way NO - pressure under the seat**



The valves with flow direction under the seat are suitable for incompressible fluids. This function prevents the hydraulic water hammer effect.

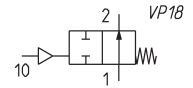

**DRAWING LEGEND:**  
 C = valve in closed position  
 O = valve in open position

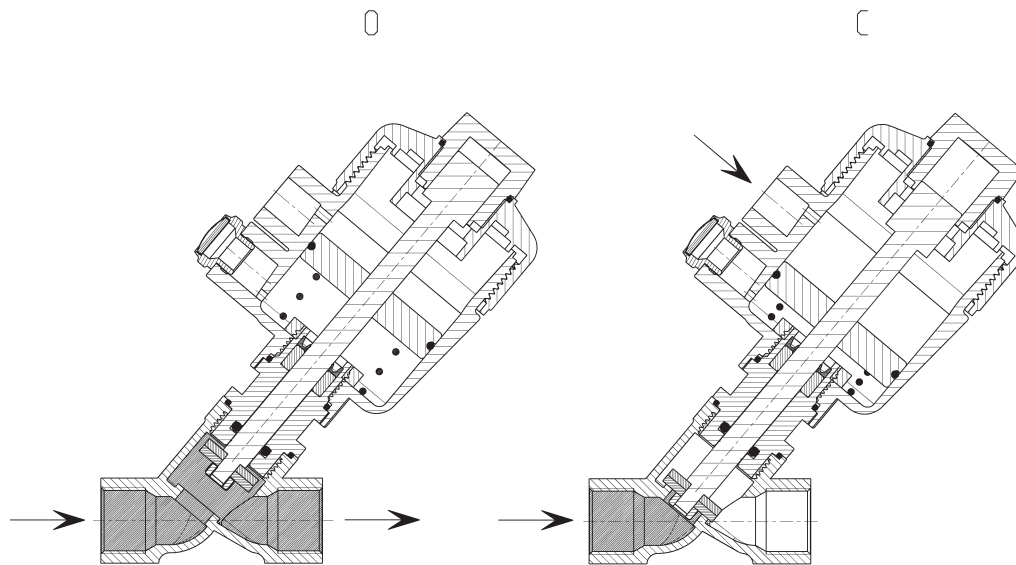

Mod.	Function	DN	Ports	Orifice Ø (mm)	Kv (m³/h)	Differential pressure min ÷ max (bar)	Minimum piloting pressure (bar)	Actuator Ø (mm)	Actuator material
ASPA0-W010G1-050P2	2/2 NO	10	G3/8"	12	2.6	0 ÷ 20	≥ 6	50	PA66
ASPA0-W015G1-050P2	2/2 NO	15	G1/2"	12	3.5	0 ÷ 20	≥ 6	50	PA66
ASPA0-W015G1-063P2	2/2 NO	15	G1/2"	12	3.5	0 ÷ 20	≥ 6	63	PA66
ASPA0-W020G1-050P2	2/2 NO	20	G3/4"	17	8.6	0 ÷ 20	6 ÷ 6.3	50	PA66
ASPA0-W020G1-063P2	2/2 NO	20	G3/4"	17	8.6	0 ÷ 20	≥ 6	63	PA66
ASPA0-W025G1-050P2	2/2 NO	25	G1"	21	9.7	0 ÷ 20	6 ÷ 8.7	50	PA66
ASPA0-W025G1-063P2	2/2 NO	25	G1"	21	9.7	0 ÷ 20	6 ÷ 6.3	63	PA66
ASPA0-W032G1-063P2	2/2 NO	32	G1 1/4"	30	26.7	0 ÷ 20	6 ÷ 9.3	63	PA66
ASPA0-W032G1-080P2	2/2 NO	32	G1 1/4"	30	26.7	0 ÷ 20	≥ 6	80	PA66
ASPA0-W040G1-080P2	2/2 NO	40	G1 1/2"	37	40.4	0 ÷ 20	6 ÷ 8.5	80	PA66
ASPA0-W040G1-100P2	2/2 NO	40	G1 1/2"	37	40.4	0 ÷ 20	≥ 6	100	PA66
ASPA0-W050G1-080P2	2/2 NO	50	G2"	46	55	0 ÷ 16	6 ÷ 10	80	PA66
ASPA0-W050G1-100P2	2/2 NO	50	G2"	46	55	0 ÷ 20	6 ÷ 7.4	100	PA66
ASPA0-W065G1-100P2	2/2 NO	65	2 1/2"	59	65	0 ÷ 14	6 ÷ 10	100	PA66

**Series ASP angle seat valve - 2/2-way DA - pressure under the seat**



The valves with flow direction under the seat are suitable for incompressible fluids. This function prevents the hydraulic water hammer effect.

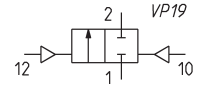

**DRAWING LEGEND:**  
C = valve in closed position  
O = valve in open position

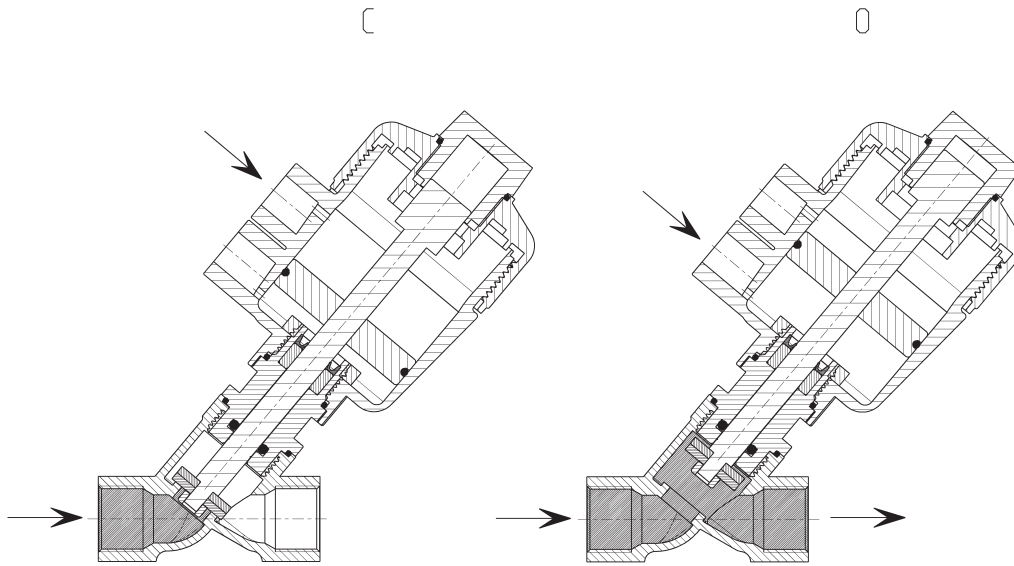

Mod.	Function	DN	Ports	Orifice Ø (mm)	Kv (m³/h)	Differential pressure min + max (bar)	Minimum piloting pressure (bar)	Actuator Ø (mm)	Actuator material
ASPA3-W010G1-050P2	2/2 DE	10	G3/8"	12	2.6	0 ÷ 20	≥ 6	50	PA66
ASPA3-W015G1-050P2	2/2 DE	15	G1/2"	12	3.5	0 ÷ 20	≥ 6	50	PA66
ASPA3-W015G1-063P2	2/2 DE	15	G1/2"	12	3.5	0 ÷ 20	≥ 6	63	PA66
ASPA3-W020G1-050P2	2/2 DE	20	G3/4"	17	8.6	0 ÷ 20	≥ 6	50	PA66
ASPA3-W020G1-063P2	2/2 DE	20	G3/4"	17	8.6	0 ÷ 20	≥ 6	63	PA66
ASPA3-W025G1-050P2	2/2 DE	25	G1"	21	9.7	0 ÷ 20	6 ÷ 8.3	50	PA66
ASPA3-W025G1-063P2	2/2 DE	25	G1"	21	9.7	0 ÷ 20	≥ 6	63	PA66
ASPA3-W032G1-063P2	2/2 DE	32	G1 1/4"	30	26.7	0 ÷ 20	6 ÷ 8	63	PA66
ASPA3-W032G1-080P2	2/2 DE	32	G1 1/4"	30	26.7	0 ÷ 20	≥ 6	80	PA66
ASPA3-W040G1-080P2	2/2 DE	40	G1 1/2"	37	40.4	0 ÷ 20	6 ÷ 7.7	80	PA66
ASPA3-W040G1-100P2	2/2 DE	40	G1 1/2"	37	40.4	0 ÷ 20	≥ 6	100	PA66
ASPA3-W050G1-080P2	2/2 DE	50	G2"	46	55	0 ÷ 16	6 ÷ 10	80	PA66
ASPA3-W050G1-100P2	2/2 DE	50	G2"	46	55	0 ÷ 20	6 ÷ 6.7	100	PA66
ASPA3-W065G1-100P2	2/2 DE	65	2 1/2"	59	65	0 ÷ 14.5	6 ÷ 10	100	PA66

**Series ASP angle seat valve - 2/2-way DA - pressure above the seat**



The valves with flow direction above the seat are suitable for compressible fluids.

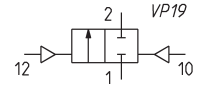

**DRAWING LEGEND:**  
C = valve in closed position  
O = valve in open position

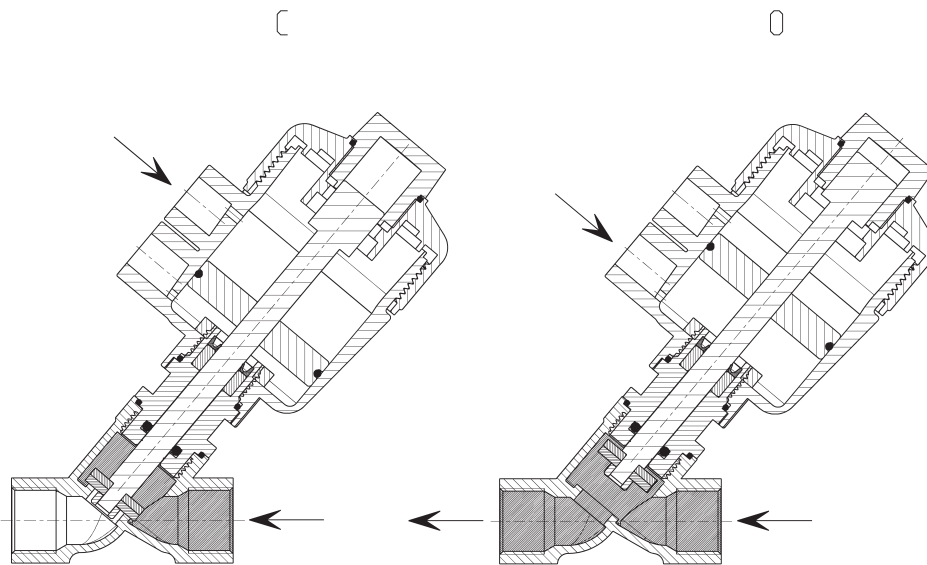

Mod.	Function	DN	Ports	Orifice Ø (mm)	Kv (m <sup>3</sup> /h)	Differential pressure min ÷ max (bar)	Minimum piloting pressure (bar)	Actuator Ø(mm)	Actuator material
ASPA3-Y010G1-050P2	2/2 DE	10	G3/8"	12	2.6	0 ÷ 20	≥ 6	50	PA66
ASPA3-Y015G1-050P2	2/2 DE	15	G1/2"	12	3.5	0 ÷ 20	≥ 6	50	PA66
ASPA3-Y015G1-063P2	2/2 DE	15	G1/2"	12	3.5	0 ÷ 20	≥ 6	63	PA66
ASPA3-Y020G1-050P2	2/2 DE	20	G3/4"	17	8.6	0 ÷ 20	≥ 6	50	PA66
ASPA3-Y020G1-063P2	2/2 DE	20	G3/4"	17	8.6	0 ÷ 20	≥ 6	63	PA66
ASPA3-Y025G1-050P2	2/2 DE	25	G1"	21	9.7	0 ÷ 20	6 ÷ 8.3	50	PA66
ASPA3-Y025G1-063P2	2/2 DE	25	G1"	21	9.7	0 ÷ 20	≥ 6	63	PA66
ASPA3-Y032G1-063P2	2/2 DE	32	G1 1/4"	30	26.7	0 ÷ 20	6 ÷ 8	63	PA66
ASPA3-Y032G1-080P2	2/2 DE	32	G1 1/4"	30	26.7	0 ÷ 20	≥ 6	80	PA66
ASPA3-Y040G1-080P2	2/2 DE	40	G1 1/2"	37	40.4	0 ÷ 20	6 ÷ 7.7	80	PA66
ASPA3-Y040G1-100P2	2/2 DE	40	G1 1/2"	37	40.4	0 ÷ 20	≥ 6	100	PA66
ASPA3-Y050G1-080P2	2/2 DE	50	G2"	46	55	0 ÷ 16	6 ÷ 10	80	PA66
ASPA3-Y050G1-100P2	2/2 DE	50	G2"	46	55	0 ÷ 20	6 ÷ 6.7	100	PA66
ASPA3-Y065G1-100P2	2/2 DE	65	2 1/2"	59	65	0 ÷ 14.5	6 ÷ 10	100	PA66

**Series ASP angle seat valve - dimensions and weight**

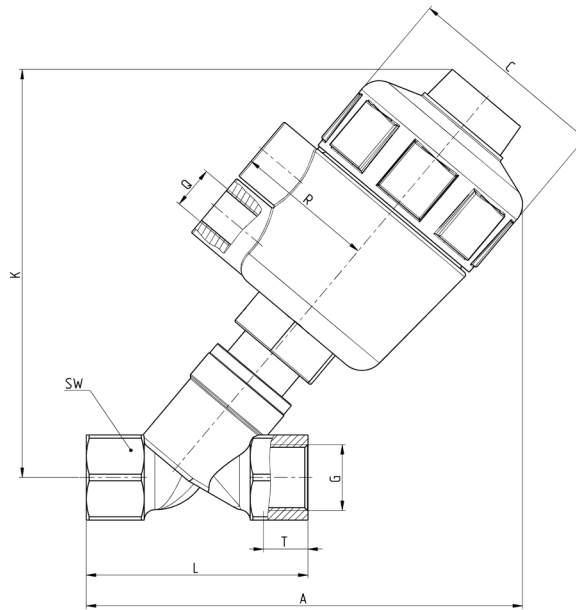

DIMENSIONS											WEIGHT
DN	Actuator Ø (mm)	G	T	A	L	SW	C	R	K	Q	Kg
10	50	3/8"	12	125	49	21	66	45	115	G1/4"	0.8
15	50	1/2"	13	130	55	26	66	45	115	G1/4"	0.9
15	63	1/2"	13	160	55	26	83	52	150	G1/4"	1.2
20	50	3/4"	13.5	135	65.5	31	66	45	115	G1/4"	1.0
20	63	3/4"	13.5	165	65.5	31	83	52	150	G1/4"	1.3
25	50	1"	16	140	76	38	66	45	115	G1/4"	1.3
25	63	1"	16	170	76	38	83	52	150	G1/4"	1.6
32	63	1 1/4"	18	180	96	48	83	52	180	G1/4"	2.1
32	80	1 1/4"	18	210	96	48	103	60	210	G1/4"	1.6
40	80	1 1/2"	18.5	220	101	54	103	60	220	G1/4"	2.6
40	100	1 1/2"	18.5	230	101	54	130	73	230	G1/4"	4.5
50	80	2"	19	230	120	67	103	60	230	G1/4"	2.9
50	100	2"	19	240	120	67	130	73	240	G1/4"	5.3
65	100	2 1/2"	23	250	149	85	130	73	240	G1/4"	6.5