



Series D valves and solenoid valves

3/2; 2x3/2; 5/2; 5/3-way

With outlets on the body - For individual or manifold assembly

Size 10,5 - 25 mm

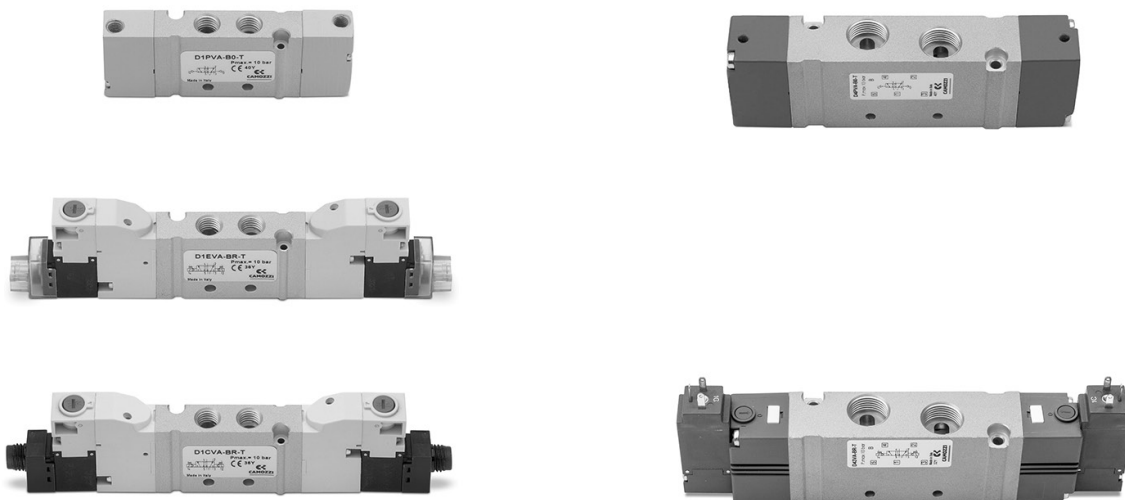

Camozzi has developed a new series of valves for applications with limited installation space where it is necessary to have the control elements as close to the actuator as possible.

Valves with threads on the body can be used individually or assembled on manifold. The sub-base version allows a better cleaning of the application.

Thanks to the extreme robust aluminium body, the Series D valves guarantee maximum reliability even under difficult operating conditions.

- » Can be used individually or in parallel groups
- » Pneumatic and electric version
- » Flow up to 2000 Nl/min
- » Aluminium body and technopolymer end caps
- » Installation in narrow spaces
- » Electric connection also with M8 connector

GENERAL DATA

Valve construction	spool- type
Valve functions	3/2 NC/NO; 2x3/2 NC/NO/NC+NO; 5/2; 5/3 CC/CO/CP
Materials	body, spool, bases = AL; end caps = technopolymer; seals = HNBR
Ports	M7 - 3/8
Ambient temperature	0°C min. + 50° C max
Medium	compressed, filtered and non-lubricated air in class 7.4.4 according to ISO 8573-1:2010. In case lubrication should be necessary, only use oils with a maximum viscosity of 32 Cst and the version with external servo pilot. The air quality for the servo pilot should be of class 7.4.4 according to ISO 8573-1:2010
Voltage	24V DC
Voltage tolerance	± 10%
Power consumption	1W
Class of insulation	class F
Protection class	IP65 with EN 175301 C connector ("3" actuation. Ex DIN 43650)* IP65 with M8 connector ("C" actuation)* IP40 with micro connector ("E" actuation)* *See coding example

CODING EXAMPLE

D	1	E	VA	-	B	P	-	BS
----------	----------	----------	-----------	----------	----------	----------	----------	-----------

D	SERIES	
1	SIZE: 1 = 10,5 mm 4 = 25 mm	
E	ACTUATION: E = electric (only for D1) 3 = electric 15 mm (only for D4) C = electric with M8 connections (only for D1) P = pneumatic	
VA	COMPONENT: VA = Valve with threaded body	
B	TYPE OF SOLENOID VALVE: M (MZ) = 5/2 Monostable B (BZ) = 5/2 Bistable P (PZ) = 3/2 NC Q (QZ) = 3/2 NO C (CZ) = 2 x 3/2 NC A (AZ) = 2 x 3/2 NO G (GZ) = 2 x 3/2 (NC+NO) N (NZ) = 5/3 CP V (VZ) = 5/3 CC K (KZ) = 5/3 CO	(.Z) = version with external servo pilot, not for pneumatic version External servo fittings: Ø4 (D1) 6512 4 - M5 Ø6 (D4) 6512 6 - M5
P	TYPE OF MANUAL OVERRIDE: P = push button (not for D4) R = with push and turn device 0 = without manual override (for version P)	
BS	CONNECTIONS: T = Thread A (AS) = Ø4 (D1) fittings 6512 4-M7-M (silencer 2931 M7) B (BS) = Ø6 (D1) fittings 6512 6-M7-M (silencer 2931 M7) D (DS) = Ø10 (D4) fittings 6512 10-3/8 (silencer 2931 3/8) E (ES) = Ø12 (D4) fittings 6512 12-3/8 (silencer 2931 3/8) F (FS) = Ø14 (D4) fittings 6512 14-3/8 (silencer 2931 3/8)	(.S) version with silencer

3/2-way pneumatically actuated valve, monostable - size 10,5

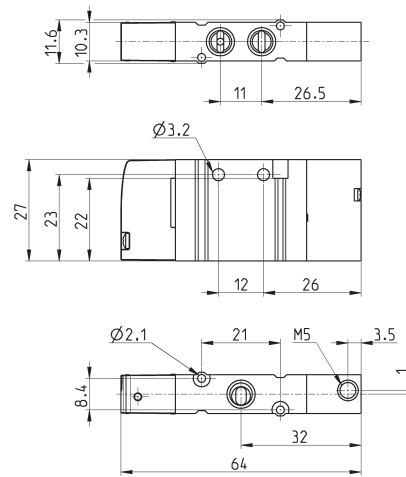
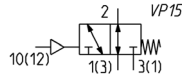
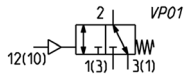

Mod.	Function	Ports	Pilot supply	Pilot supply pressure (bar)	Operating pressure (bar)	Flow (NL/min)	Symbol
D1PVA-P0-T	NC	M7	M5	2.5 ÷ 10	-0.9 ÷ 10	200	VP01
D1PVA-Q0-T	NO	M7	M5	2.5 ÷ 10	-0.9 ÷ 10	200	VP15

5/2-way pneumatically actuated valve, monostable - size 10,5

N.B. the pilot pressure should never be lower than the operating pressure.

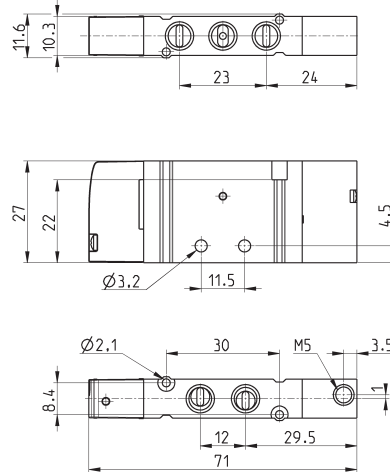
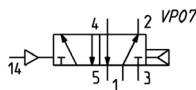

Mod.	Ports	Pilot supply	Pilot supply pressure (bar)	Operating pressure (bar)	Flow (NL/min)
D1PVA-M0-T	M7	M5	2.5 ÷ 10	2.5 ÷ 10	270

5/2-way pneumatically actuated valve, bistable - size 10,5

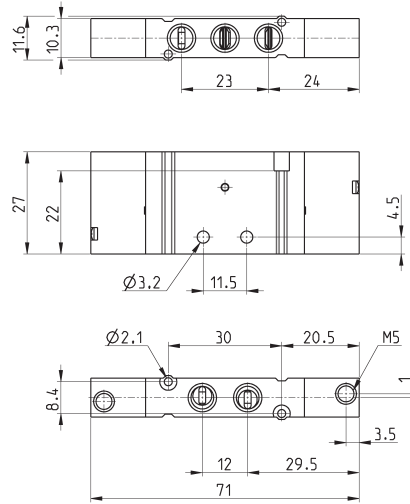
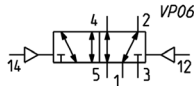

Mod.	Ports	Pilot supply	Pilot supply pressure (bar)	Operating pressure (bar)	Flow (NL/min)
D1PVA-B0-T	M7	M5	1.5 ÷ 10	-0.9 ÷ 10	270

5/3-way pneumatically actuated valve - size 10,5

CC = Centres Closed
CO = Centres Open
CP = Centres Pressurized

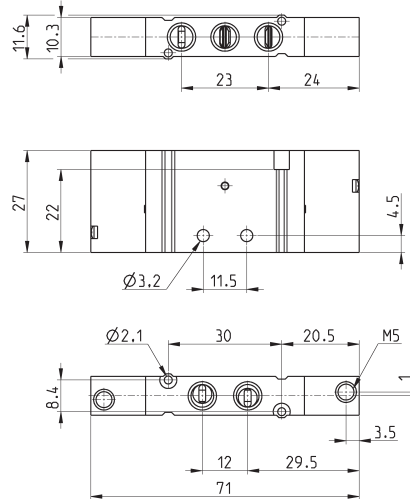
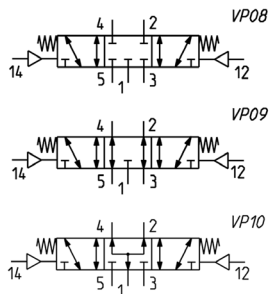

Mod.	Function	Ports	Pilot supply	Pilot supply pressure (bar)	Operating pressure (bar)	Flow (NL/min)	Symbol
D1PVA-V0-T	CC	M7	M5	2.5 ÷ 10	-0.9 ÷ 10	250	VP08
D1PVA-K0-T	CO	M7	M5	2.5 ÷ 10	-0.9 ÷ 10	220	VP09
D1PVA-N0-T	CP	M7	M5	2.5 ÷ 10	-0.9 ÷ 10	220	VP10

2X3/2 -way pneumatically actuated valve - size 10,5

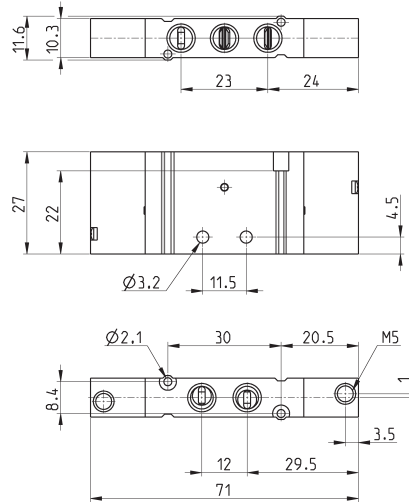
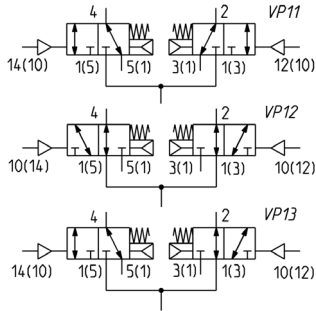

Mod.	Function	Ports	Pilot supply	Pilot supply pressure (bar)	Operating pressure (bar)	Flow (NL/min)	Symbol
D1PVA-C0-T	NC	M7	M5	2.5 ÷ 10	-0.9 ÷ 10	250	VP11
D1PVA-A0-T	NO	M7	M5	2.5 ÷ 10	-0.9 ÷ 10	220	VP12
D1PVA-G0-T	NC+NO	M7	M5	2.5 ÷ 10	-0.9 ÷ 10	220	VP13

3/2-way pneumatically actuated valve, monostable - size 25

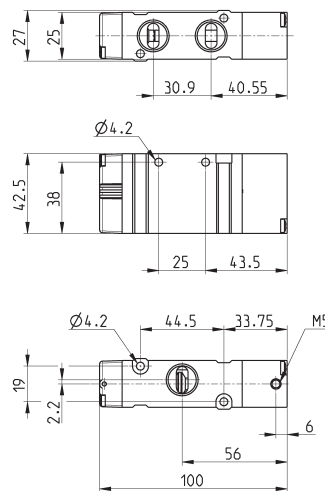
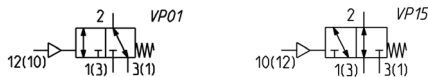

Mod.	Function	Ports	Pilot supply	Pilot supply pressure (bar)	Operating pressure (bar)	Flow (NL/min)	Symbol
D4PVA-P0-T	NC	G3/8	M5	2.5 ÷ 10	-0.7 ÷ 10	1800	VP01
D4PVA-Q0-T	NO	G3/8	M5	2.5 ÷ 10	-0.7 ÷ 10	1800	VP15

5/2-way pneumatically actuated valve, monostable - size 25



Note: the pilot pressure should never be lower than the operating pressure.

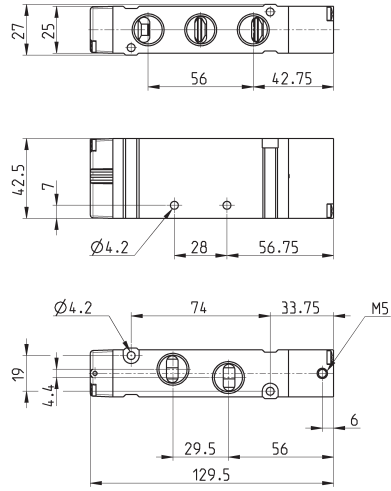
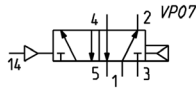

Mod.	Ports	Pilot supply	Pilot supply pressure (bar)	Operating pressure (bar)	Flow (NI/min)
D4PVA-M0-T	G3/8	M5	2.5 ÷ 10	2.5 ÷ 10	2000

5/2-way pneumatically actuated valve, bistable - size 25

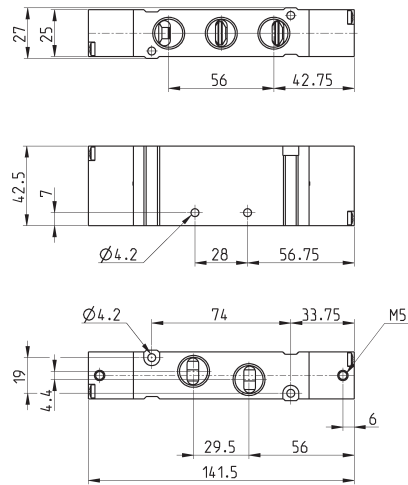
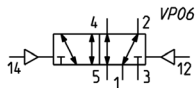

Mod.	Ports	Pilot supply	Pilot supply pressure (bar)	Operating pressure (bar)	Flow (NI/min)
D4PVA-B0-T	G3/8	M5	1.5 ÷ 10	-0.9 ÷ 10	2000

5/3-way pneumatically actuated valve - size 25



CC = Centres Closed
 CO = Centres Open
 CP = Centres Pressurized

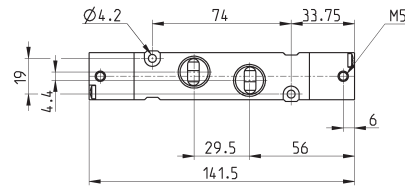
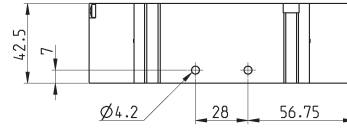
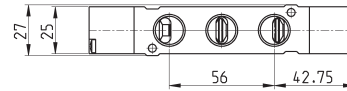
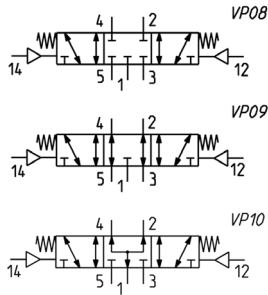

Mod.	Function	Ports	Pilot supply	Pilot supply pressure (bar)	Operating pressure (bar)	Flow (NL/min)	Symbol
D4PVA-V0-T	CC	G3/8	M5	2.5 ÷ 10	-0.9 ÷ 10	1800	VP08
D4PVA-K0-T	CO	G3/8	M5	2.5 ÷ 10	-0.9 ÷ 10	1800	VP09
D4PVA-N0-T	CP	G3/8	M5	2.5 ÷ 10	-0.9 ÷ 10	1800	VP10

2X3/2-way pneumatically actuated valve - size 25

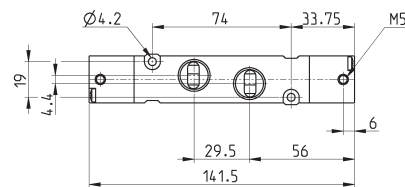
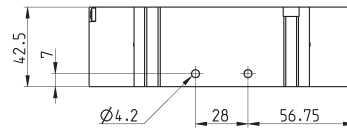
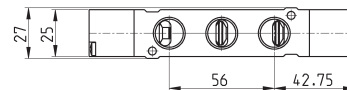
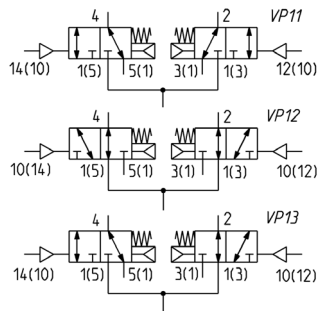

Mod.	Function	Ports	Pilot supply	Pilot supply pressure (bar)	Operating pressure (bar)	Flow (NL/min)	Symbol
D4PVA-C0-T	NC	G3/8	M5	3 ÷ 10	-0.7 ÷ 10	1800	VP11
D4PVA-A0-T	NO	G3/8	M5	3 ÷ 10	-0.7 ÷ 10	1800	VP12
D4PVA-G0-T	NO+NC	G3/8	M5	3 ÷ 10	-0.7 ÷ 10	1800	VP13

3/2-way solenoid valve, monostable - size 10,5



The indications given are valid for the versions D1EVA and D1CVA.
The symbols of the versions with manual override type P are shown in the Appendix.

Connectors at the end of this section

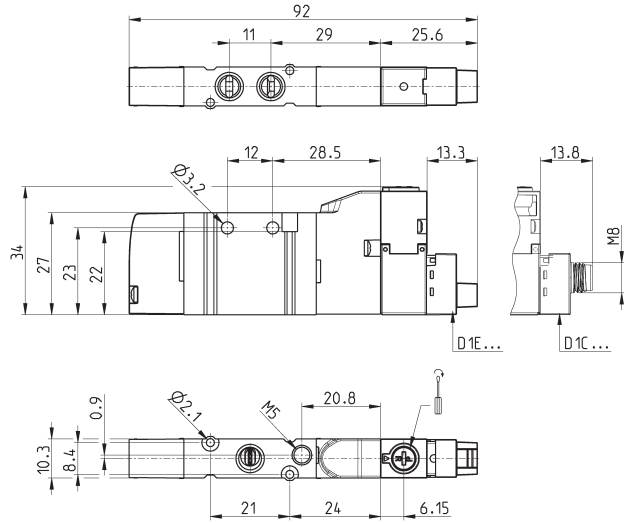
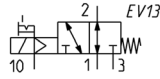
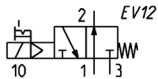
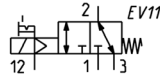
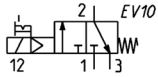

Mod.	Function	Ports	Pilot supply	Pilot supply pressure (bar)	Operating pressure (bar)	Flow (NL/min)	Symbol
D1EVA-PR-T / D1CVA-PR-T	NC	M7	-	-	2.5 ÷ 7	200	EV10
D1EVA-PZR-T / D1CVA-PZR-T	NC	M7	M5	2.5 ÷ 7	-0.9 ÷ 10	200	EV11
D1EVA-QR-T / D1CVA-QR-T	NO	M7	-	-	2.5 ÷ 7	200	EV12
D1EVA-QZR-T - D1CVA-QZR-T	NO	M7	M5	2.5 ÷ 7	-0.9 ÷ 10	200	EV13

5/2-way solenoid valve, monostable - size 10,5



The indications given are valid for the versions D1EVA and D1CVA.
The symbols of the versions with manual override type P are shown in the Appendix.

Connectors at the end of this section

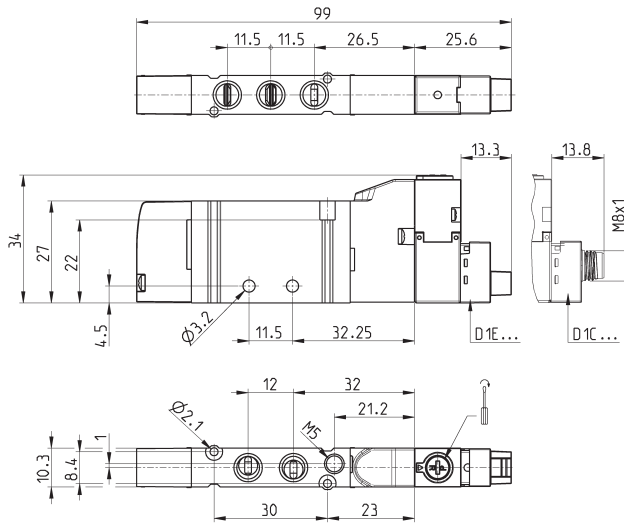
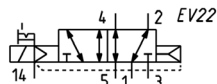
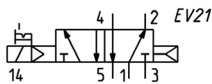

Mod.	Ports	Pilot supply	Pilot supply pressure (bar)	Operating pressure (bar)	Flow (NL/min)	Symbol
D1EVA-MR-T / D1CVA-MR-T	M7	-	-	2.5 ÷ 7	270	EV21
D1EVA-MZR-T / D1CVA-MZR-T	M7	M5	2.5 ÷ 7	-0.9 ÷ 10	270	EV22

5/2-way solenoid valve, bistable - size 10,5



The indications given are valid for the versions D1EVA and D1CVA.
The symbols of the versions with manual override type P are shown in the Appendix.

Connectors at the end of this section

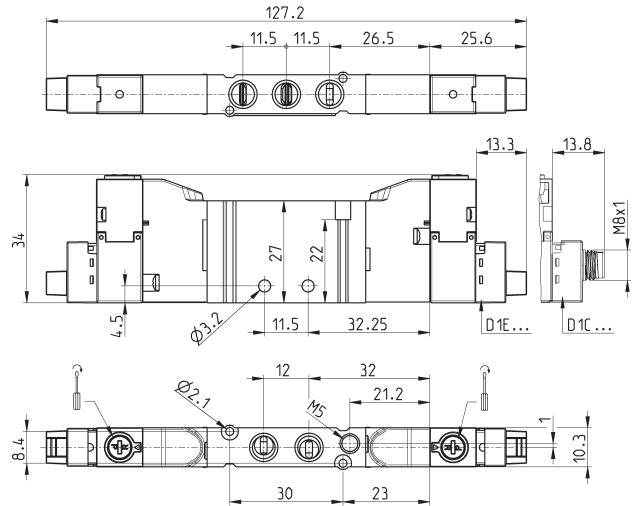
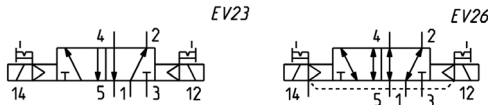

Mod.	Ports	Pilot supply	Pilot supply pressure (bar)	Operating pressure (bar)	Flow (NL/min)	Symbol
D1EVA-BR-T / D1CVA-BR-T	M7	-	-	1.5 ÷ 7	270	EV23
D1EVA-BZR-T / D1CVA-BZR-T	M7	M5	1.5 ÷ 7	-0.9 ÷ 10	270	EV26

5/3 - way solenoid valve - size 10,5



CC = Centres Closed
CO = Centres Open
CP = Centres Pressurized
The indications given are valid for the versions D1EVA and D1CVA.
The symbols of the versions with manual override type P are shown in the Appendix.

Connectors at the end of this section

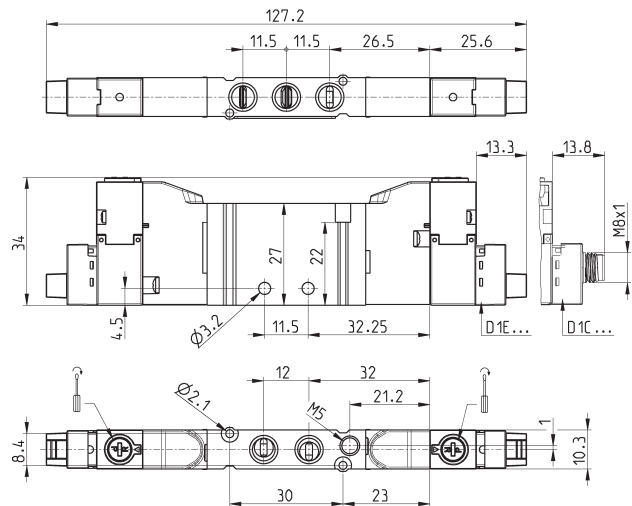
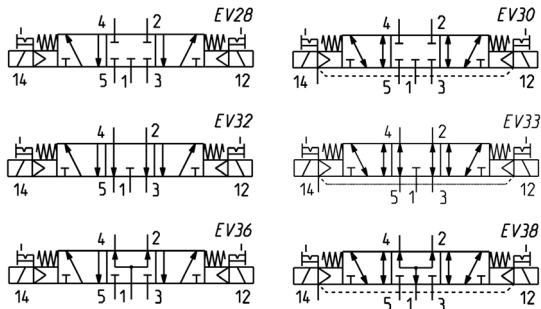

Mod.	Function	Ports	Pilot supply	Pilot supply pressure (bar)	Operating pressure (bar)	Flow (NL/min)	Symbol
D1EVA-VR-T / D1CVA-VR-T	CC	M7	-	-	2.5 ÷ 7	250	EV28
D1EVA-VZR-T / D1CVA-VZR-T	CC	M7	M5	2.5 ÷ 7	-0.9 ÷ 10	250	EV30
D1EVA-KR-T / D1CVA-KR-T	CO	M7	-	-	2.5 ÷ 7	220	EV32
D1EVA-KZR-T / D1CVA-KZR-T	CO	M7	M5	2.5 ÷ 7	-0.9 ÷ 10	220	EV33
D1EVA-NR-T / D1CVA-NR-T	CP	M7	-	-	2.5 ÷ 7	220	EV36
D1EVA-NZR-T / D1CVA-NZR-T	CP	M7	M5	2.5 ÷ 7	-0.9 ÷ 10	220	EV38

2x3/2-way solenoid valve - size 10,5



These solenoid valves integrate two independent 3/2-way functions in the same body.
The indications given are valid for the versions D1EVA and D1CVA.
The symbols of the versions with manual override type P are shown in the Appendix.

Connectors at the end of this section

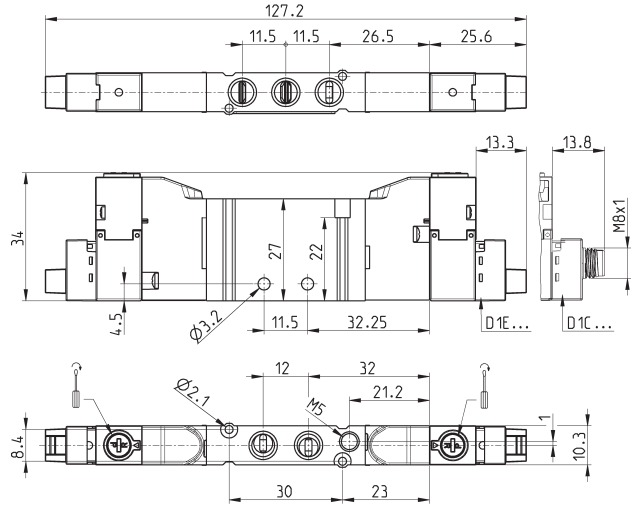
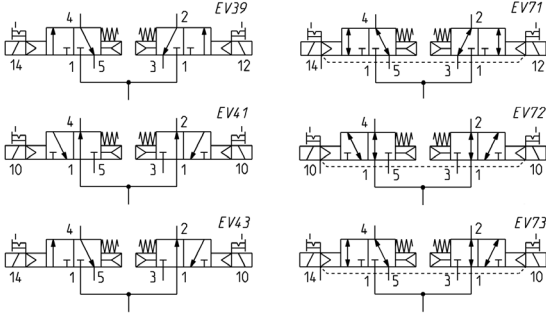

Mod.	Function	Ports	Pilot supply	Pilot supply pressure (bar)	Operating pressure (bar)	Flow (Nl/min)	Symbol
D1EVA-CR-T / D1CVA-CR-T	2 x 3/2 NC	M7	-	-	2.5 - 7	250	EV39
D1EVA-CZR-T / D1CVA-CZR-T	2 x 3/2 NC	M7	M5	2.5 - 7	-0.9 ÷ 10	250	EV71
D1EVA-AR-T / D1CVA-AR-T	2 x 3/2 NO	M7	-	-	2.5 - 7	220	EV41
D1EVA-AZR-T / D1CVA-AZR-T	2 x 3/2 NO	M7	M5	2.5 - 7	-0.9 ÷ 10	220	EV72
D1EVA-GR-T / D1CVA-GR-T	1 x 3/2 NC + 1 x 3/2 NO	M7	-	-	2.5 - 7	220	EV43
D1EVA-GZR-T / D1CVA-GZR-T	1 x 3/2 NC + 1 x 3/2 NO	M7	M5	2.5 - 7	-0.9 ÷ 10	220	EV73

Dimensions of the different versions with fittings / fitt. + silencer - size 10,5

See coding at the beginning of this section

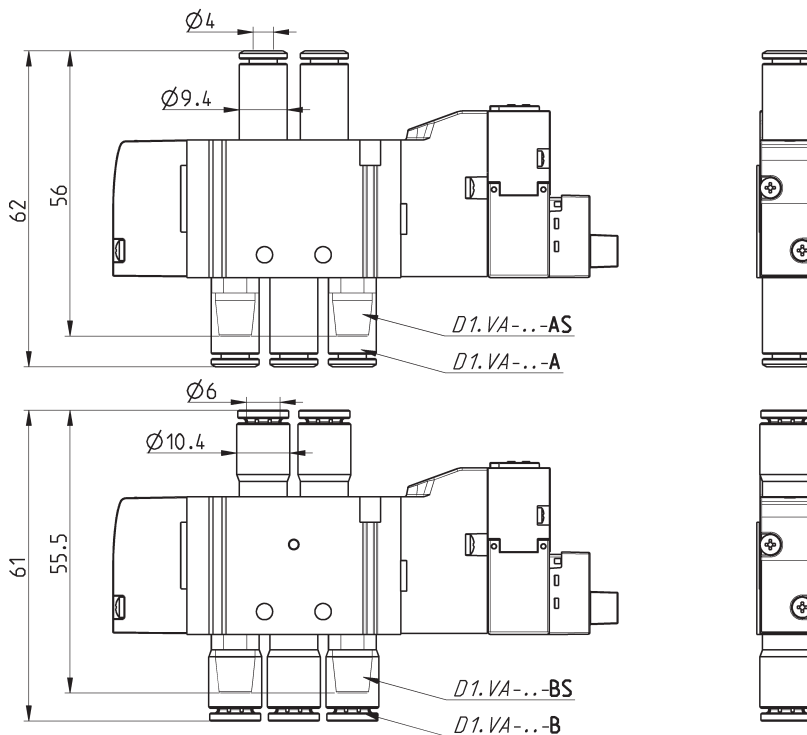

3/2-way solenoid valve, monostable - size 25



Connectors at the end of this section

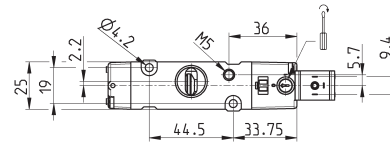
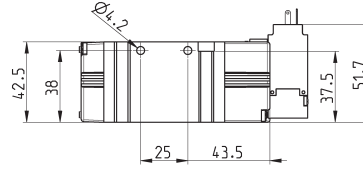
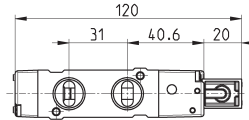
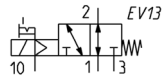
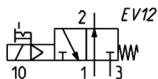
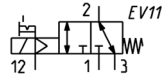
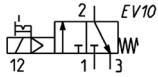

Mod.	Function	Ports	Pilot supply	Pilot supply pressure (bar)	Operating pressure (bar)	Flow (NL/min)	Symbol
D43VA-PR-T	NC	G3/8	-	-	2.5 ÷ 10	1800	EV10
D43VA-PZR-T	NC	G3/8	M5	2.5 ÷ 10	-0.9 ÷ 10	1800	EV11
D43VA-QR-T	NO	G3/8	-	-	2.5 ÷ 10	1800	EV12
D43VA-QZR-T	NO	G3/8	M5	2.5 ÷ 10	-0.9 ÷ 10	1800	EV13

5/2-way solenoid valve, monostable - size 25



Connectors at the end of this section

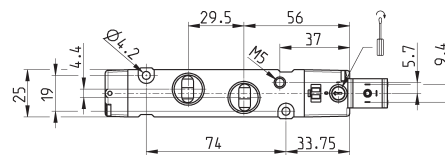
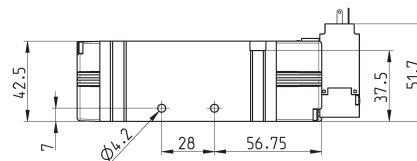
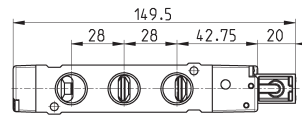
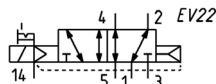
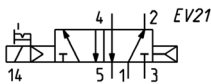

Mod.	Ports	Pilot supply	Pilot supply pressure (bar)	Operating pressure (bar)	Flow (NL/min)	Symbol
D43VA-MR-T	G3/8	-	-	2.5 ÷ 10	2000	EV21
D43VA-MZR-T	G3/8	M5	2.5 ÷ 10	-0.9 ÷ 10	2000	EV22

5/2-way solenoid valve, bistable - size 25



Connectors at the end of this section

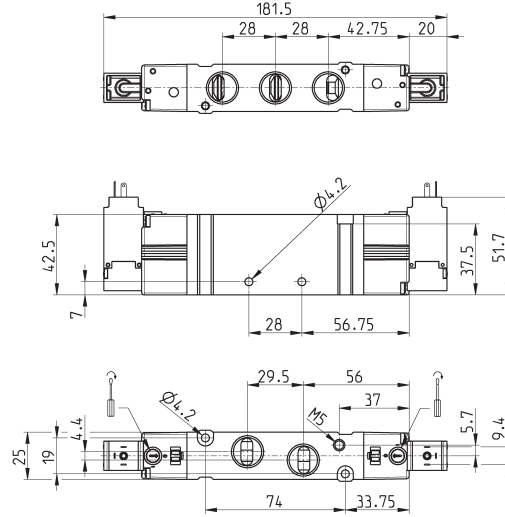
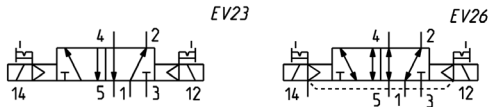

Mod.	Ports	Pilot supply	Pilot supply pressure (bar)	Operating pressure (bar)	Flow (NL/min)	Symbol
D43VA-BR-T	G3/8	-	-	1.5 ÷ 10	2000	EV23
D43VA-BZR-T	G3/8	M5	1.5 ÷ 10	-0.9 ÷ 10	2000	EV26

5/3-way solenoid valve - size 25

CC = Centres Closed
CO = Centres Open
CP = Centres Pressurized



Connectors at the end of this section

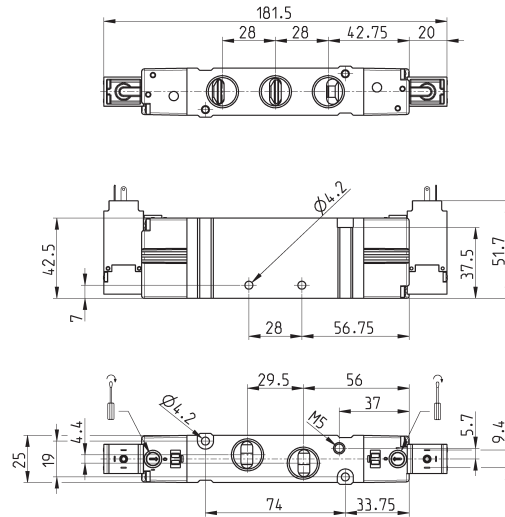
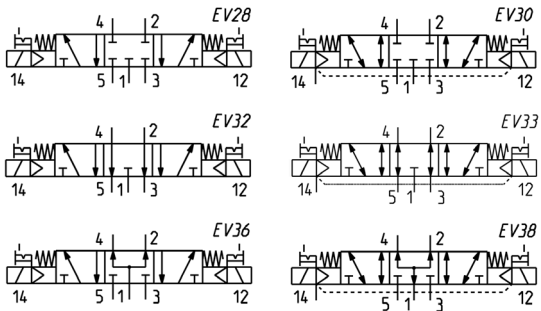

Mod.	Function	Ports	Pilot supply	Pilot supply pressure (bar)	Operating pressure (bar)	Flow (NL/min)	Symbol
D43VA-VR-T	CC	G3/8	-	-	2.5 ÷ 10	1800	EV28
D43VA-VZR-T	CC	G3/8	M5	2.5 ÷ 10	-0.9 ÷ 10	1800	EV30
D43VA-KR-T	CO	G3/8	-	-	2.5 ÷ 10	1800	EV32
D43VA-KZR-T	CO	G3/8	M5	2.5 ÷ 10	-0.9 ÷ 10	1800	EV33
D43VA-NR-T	CP	G3/8	-	-	2.5 ÷ 10	1800	EV36
D43VA-NZR-T	CP	G3/8	M5	2.5 ÷ 10	-0.9 ÷ 10	1800	EV38

2x3/2-way solenoid valve - size 25

Solenoid valves available in versions with 2x3/2-way valves on the same valve body

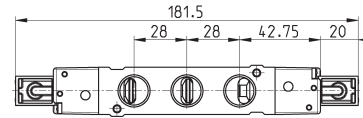

Connectors at the end of this section

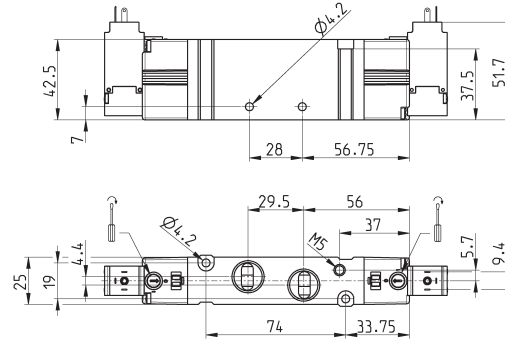
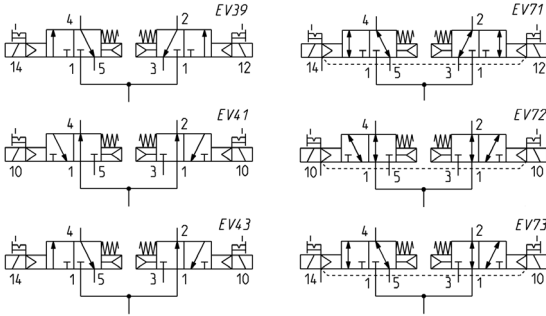

Mod.	Function	Ports	Pilot supply	Pilot supply pressure (bar)	Operating pressure (bar)	Flow (NI/min)	Symbol
D43VA-CR-T	2 x 3/2 NC	G3/8	-	-	3.5 ÷ 10	1800	EV39
D43VA-CZR-T	2 x 3/2 NC	G3/8	M5	3.5 ÷ 10	-0.7 ÷ 10	1800	EV71
D43VA-AR-T	2 x 3/2 NO	G3/8	-	-	3.5 ÷ 10	1800	EV41
D43VA-AZR-T	2 x 3/2 NO	G3/8	M5	3.5 ÷ 10	-0.7 ÷ 10	1800	EV72
D43VA-GR-T	1 x 3/2 NC + 1 x 3/2 NO	G3/8	-	-	3.5 ÷ 10	1800	EV43
D43VA-GZR-T	1 x 3/2 NC + 1 x 3/2 NO	G3/8	M5	3.5 ÷ 10	-0.7 ÷ 10	1800	EV73

Dimensions of the different versions with fittings / fitt. + silencer - size 25

See coding at the beginning of this section

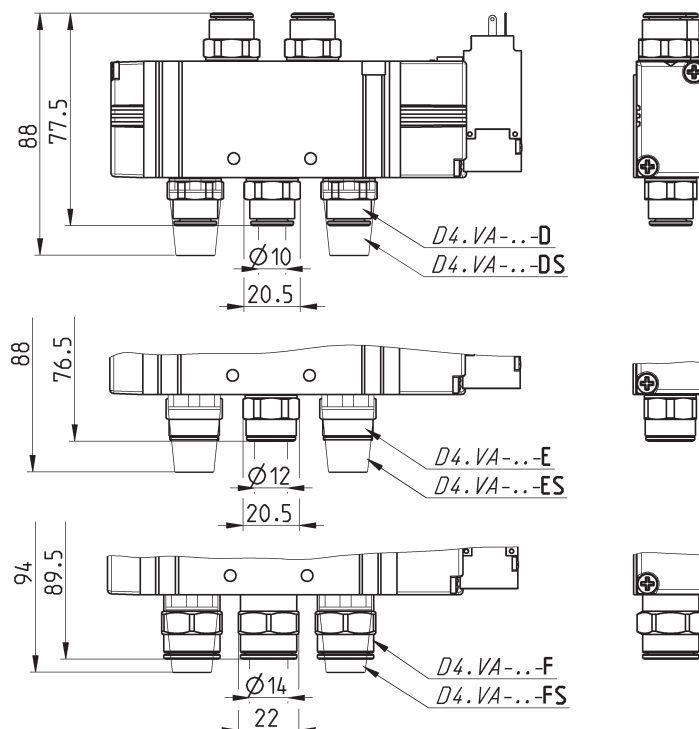

CODING EXAMPLE

DC	A	1	0	-	12
-----------	----------	----------	----------	----------	-----------

DC	SERIES
A	MANIFOLD: A = For type VA valves
1	SIZE 1 = SIZE 10.5 4 = SIZE 25
0	BODYTYPE 0 = body for sub-base assembly
12	N° OF POSITIONS: 2 3 4 ... 19

SERIES D VALVES AND SOLENOID VALVES

Manifolds for valves with outlets on the body Size 10,5

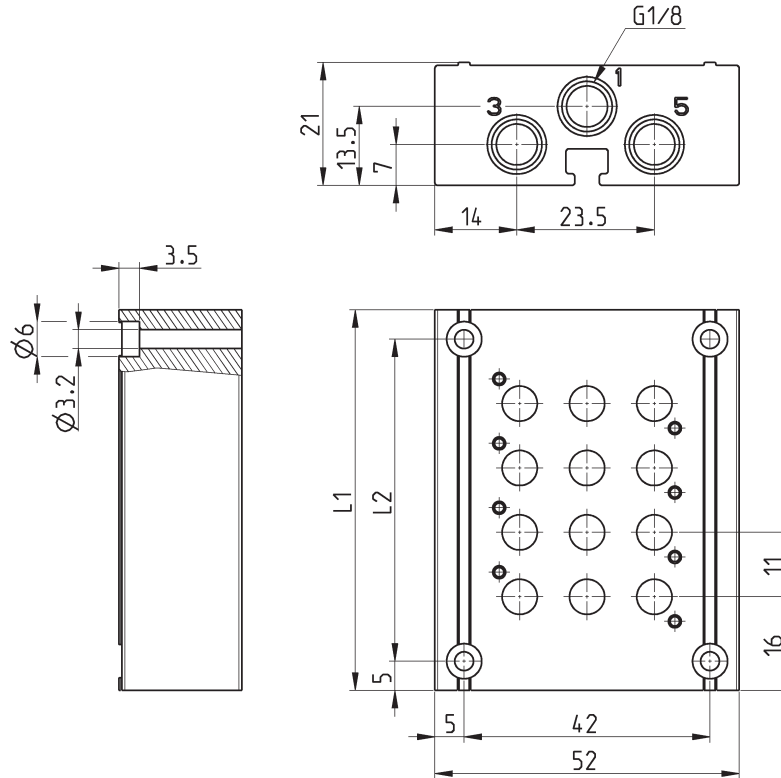

Note: the manifolds are supplied with seals and valves fixing screws.

DIMENSIONS

Mod.	Nr positions	L1	L2
DCA10-2	2	43	33
DCA10-3	3	54	44
DCA10-4	4	65	55
DCA10-5	5	76	66
DCA10-6	6	87	77
DCA10-7	7	98	88
DCA10-8	8	109	99
DCA10-9	9	120	110
DCA10-10	10	131	121
DCA10-11	11	142	132
DCA10-12	12	153	143
DCA10-13	13	164	154
DCA10-14	14	175	165
DCA10-15	15	186	176
DCA10-16	16	197	187
DCA10-17	17	208	198
DCA10-18	18	219	209
DCA10-19	19	230	220

Manifolds for valves with outlets on the body Size 25

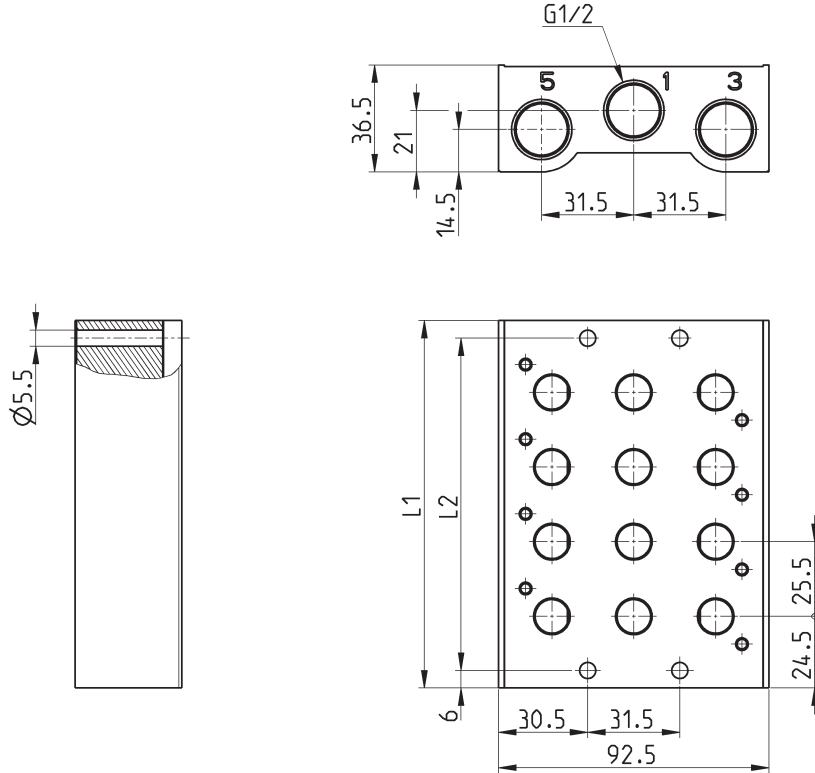

Note: the manifolds are supplied with seals and valves fixing screws.

DIMENSIONS			
Mod.	Nr positions	L1	L2
DCA40-2	2	74.5	49
DCA40-3	3	100	74.5
DCA40-4	4	125.5	100
DCA40-5	5	151	125.5
DCA40-6	6	176.5	151
DCA40-7	7	202	176.5
DCA40-8	8	227.5	202
DCA40-9	9	253	227.5
DCA40-10	10	278	253
DCA40-11	11	304	278
DCA40-12	12	329.5	304
DCA40-13	13	355	329.5
DCA40-14	14	380.5	355
DCA40-15	15	406	380.5
DCA40-16	16	431.5	406

CODING EXAMPLE MANIFOLD WITH VALVES AND FITTINGS

DC	A	1	E	P	-	MBMXCVB	-	3BX2AB	-	CSL	-	R
-----------	----------	----------	----------	----------	----------	----------------	----------	---------------	----------	------------	----------	----------

DC	SERIES
A	MANIFOLD WITH VALVES A = For type VA valve
1	SIZE 1 = SIZE 10,5 4 = SIZE 25
E	ACTUATION E = Electric (only for D1) 3 = Electric with solenoid 15 mm (only for D4) C = Electric with M8 connector (only for D1) P = Pneumatic
P	TYPE OF MANUAL OVERRIDE P = push button (not for D4) R = with push and turn device 0 = without manual override (for version P)
MBMXCVB	TYPE OF VALVE / SOLENOID VALVE M (MZ) = 5/2 Monostable B (BZ) = 5/2 Bistable C (CZ) = 2 x 3/2 NC A (AZ) = 2 x 3/2 NO G (GZ) = 2 x 3/2 (NC + NO) V (VZ) = 5/3 CC K (KZ) = 5/3 CO N (NZ) = 5/3 CP L = Free position X = Additional supply and exhaust Y = Additional supply and exhaust with silencer (.Z) = Version with external servo pilot, not for pneumatic version External servo fittings: Ø4 (D1) 6512 4-M5 Ø6 (D4) 6512 6-M5
3BX2AB	CONNECTIONS ON VALVE POSITIONS T = Thread A = Fittings Ø4 (D1) B = Fittings Ø6 (D1) C = Fittings Ø8 (D4) D = Fittings Ø10 (D4) E = Fittings Ø12 (D4) F = Fittings Ø14 (D4) L = Free position (code D1AVA-L) X = Additional supply and exhaust (code D1AVA-X) Y = Additional supply and exhaust with silencer (code D1AVA-Y)
CSL	MANIFOLD CONNECTIONS T = Thread C (CS) = Fittings Ø 8 (D1), 6512 8-1/8-M (Silnecer 2931 1/8) D (DS) = Fittings Ø 10 (D4), 6512 10-1/8-M (Silnecer 2931 1/8) E (ES) = Fittings Ø 12 (D4), S6510 12-1/2 (Silnecer 2931 1/2) F (FS) = Fittings Ø 14 (D4), S6510 14-1/2 (Silnecer 2931 1/2) CONNECTION SIDE = both L = left (right closed) R = right (left closed) (.S) Version with silencer
R	FIXING: = DIRECT R = PORT FOR DIN RAIL

Manifold with valves, outlets on the body - size 10,5

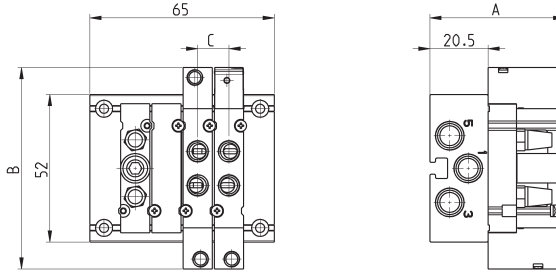

DIMENSIONS			
Mod.	A	B	C
DCA1P0-	47.5	71	10.5

Manifold with solenoid valves, outlets on the body - size 10,5

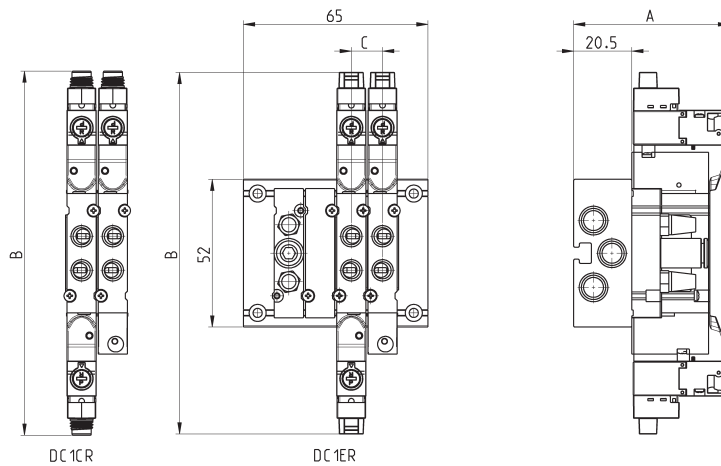

DIMENSIONS			
Mod.	A	B	C
DCA1ER-	55	127.2	10.5
DCA1CR-	55	128.2	10.5

Manifold with valves, outlets on the body - size 25

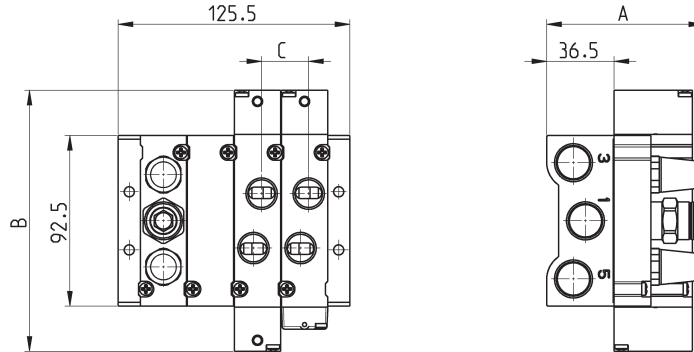

DIMENSIONS			
Mod.	A	B	C
DCA4P0-	85	141.5	25

Manifold with solenoid valves, outlets on the body - size 25

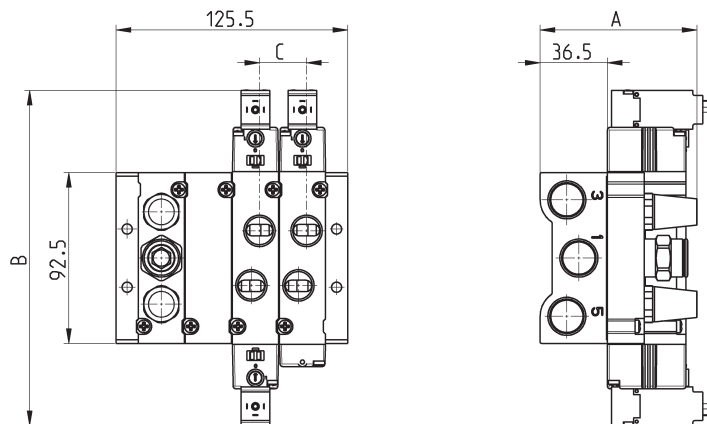

DIMENSIONS			
Mod.	A	B	C
DCA43R-	85	181.5	25

Mounting brackets for DIN rail



DIN EN 50022 (7,5mm x 35mm - width 1)
Suitable for all manifolds.

Supplied with:
2x plates
2x screws M4x6 UNI 5931

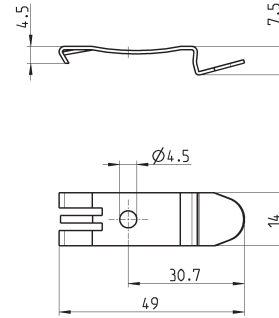

Mod.
PCF-E520

Blanking plate for manifolds - free position L

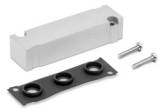

The following is supplied:
1x plate
2x screws
1x seal.

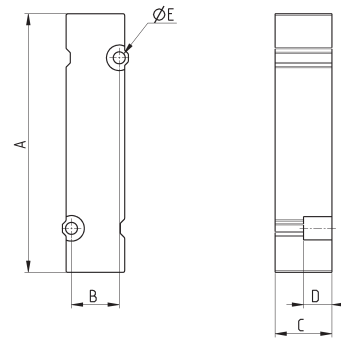

DIMENSIONS						
Mod.	Size	A	B	C	D	ØE
D1AVA-L	10,5	45.5	8.4	10	5	2.1
D4AVA-L	25	92.5	19	20	5	4.2

Module X for additional supply and exhaust for size 10,5



The following is supplied:
1x plate
2x screws
1x seal.
1x fitting 6512 6-M7
2x fittings 6512 4-M5

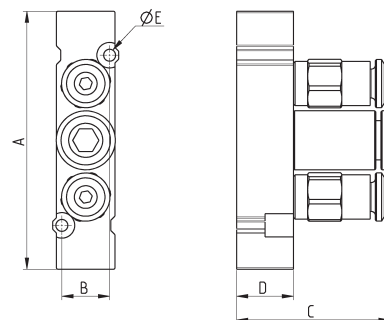

DIMENSIONS						
Mod.	Size	A	B	C	D	ØE
D1AVA-X	10.5	45.5	8.4	27	10	2.1

Module X for additional supply and exhaust for size 25



The following is supplied:
 1x plate
 2x screws
 1x seal.
 3x fittings 6512 12-3/8

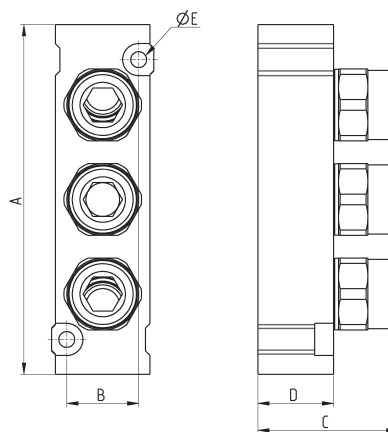

DIMENSIONS						
Mod.	Size	A	B	C	D	ØE
D4AVA-X	25.5	92.5	19	37	20	4.2

Module Y for additional supply and exhaust with silencer for size 10,5



The following is supplied:
 1x plate
 2x screws
 1x seal.
 2x silencers 2931 M5
 1x fitting 6512 6-M7

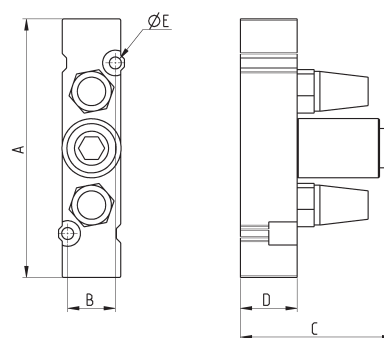

DIMENSIONS						
Mod.	Size	A	B	C	D	ØE
D1AVA-Y	11	45.5	8.4	27	10	2,1

Module Y for additional supply and exhaust with silencer for size 25



The following is supplied:
 1x plate
 2x screws
 1x seal.
 2x silencers 2931 3/8
 1x fitting 6512 12-3/8

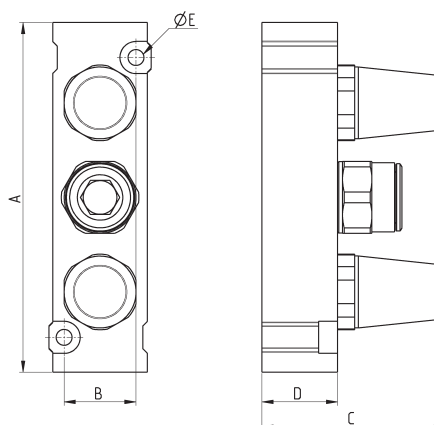

DIMENSIONS						
Mod.	Size	A	B	C	D	ØE
D4AVA-Y	25	92.5	19	48.5	20	4.2

Connector Mod. 121-8..

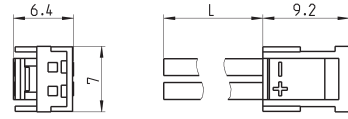

Mod.	description	colour	L = cable length (mm)	cable holding
121-803	crimped cable	black	300	crimping
121-806	crimped cable	black	600	crimping
121-810	crimped cable	black	1000	crimping
121-830	crimped cable	black	3000	crimping

3-wire extension with M8 3-pin female connector for "C" actuation



With PU sheathing, non shielded cable.
Protection class: IP65

- 1 BN = Brown
- 4 BK = Black
- 3 BU = Blue

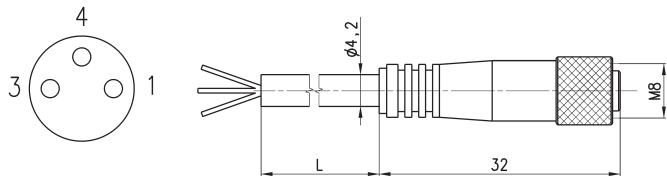

Mod.	L = cable length (m)
CS-2	2
CS-5	5
CS-10	10

3-wire extension with M8 3-pin male / female connector for "C" actuation

Non shielded

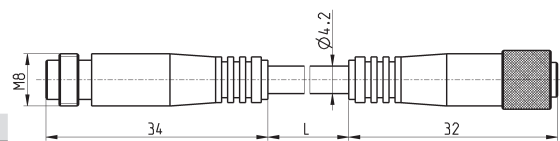

Mod.	cable length "L" (m)
CS-DW03HB-C250	2,5
CS-DW03HB-C500	5

Connector Mod. 125-... pitch 9.4 mm for "3" actuation

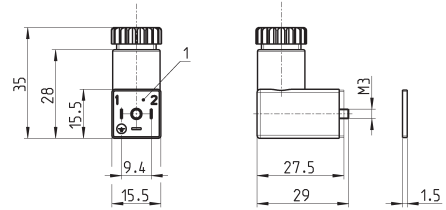

Mod.	description	colour	working voltage	cable holding	tightening torque
125-601	connector, diode + Led	transparent	10/50 V DC	PG7	0.3 Nm
125-701	connector, varistor + Led	transparent	24 V AC/DC	PG7	0.3 Nm
125-800	connector, without electronics	black	-	PG7	0.3 Nm

1 = 90° adjustable connector

Connector Mod. 125-... pitch 9.4 mm with cable for "C" actuation

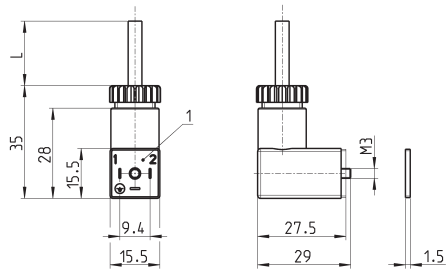

Mod.	description	colour	working voltage	cable length [L]	cable gland	tightening torque
125-501-2	moulded cable with diode + Led	black	10/50 V DC	2000 mm	-	0.3 Nm
125-550-1	moulded cable, without electronics	black	-	1000 mm	-	0.3 Nm

1 = 90° adjustable connector

In-line connectors with cable for "E" actuation

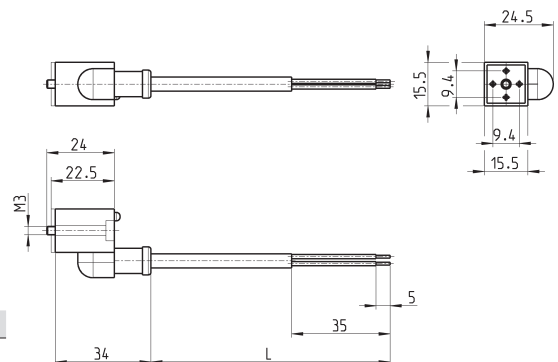

Mod.	description	colour	working voltage	cable length [L]	cable gland	tightening torque
125-503-2	in-line moulded cable, with diode + Led	black	24 V DC	2000 mm	-	0.3 Nm
125-503-5	in-line moulded cable, with diode + Led	black	24 V DC	5000 mm	-	0.3 Nm
125-553-2	in-line moulded cable, without electronics	black	-	2000 mm	-	0.3 Nm
125-553-5	in-line moulded cable, without electronics	black	-	5000 mm	-	0.3 Nm

CODING EXAMPLE

D	1	E	VB	-	B	P
----------	----------	----------	-----------	----------	----------	----------

D	SERIES
1	SIZE: 1 = 10.5 mm 4 = 25 mm
E	ACTUATION: E = electric (only for D1) 3 = electric 15 mm (only for D4) C = electric with connection M8 (only for D1)
VB	COMPONENT: VB = Valve with subbase body
B	TYPE OF SOLENOID VALVE: M = 5/2 Monostable B = 5/2 Bistable C = 2 x 3/2 NC A = 2 x 3/2 NO G = 2 x 3/2 (NC+NO) N = 5/3 CP V = 5/3 CC K = 5/3 CO
P	TYPE OF MANUAL OVERRIDE: P = push button (not for D4) R = with push and turn device
In case of applications with alternate current, use a bridge rectifier connector, only for D4. (see the connectors at the end of the section)	

5/2-way solenoid valve, monostable, outlets on subbase - size 10.5



The indications given are valid for the versions D1EVA and D1CVA. The symbols of the versions with manual override type P are shown in the Appendix.

Connectors at the end of this section

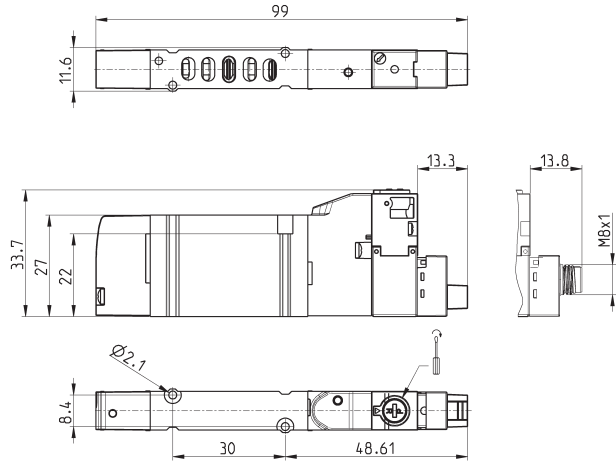
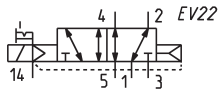

Mod.	Pilot supply pressure (bar)	Operating pressure (bar)	Flow (NL/min)	Symbol
D1EVB-MR / D1CVB-MR	2.5 ÷ 7	-0.9 ÷ 10	300	EV22

5/2-way solenoid valve, bistable, outlets on subbase - size 10.5



The indications given are valid for the versions D1EVA and D1CVA. The symbols of the versions with manual override type P are shown in the Appendix.

Connectors at the end of this section

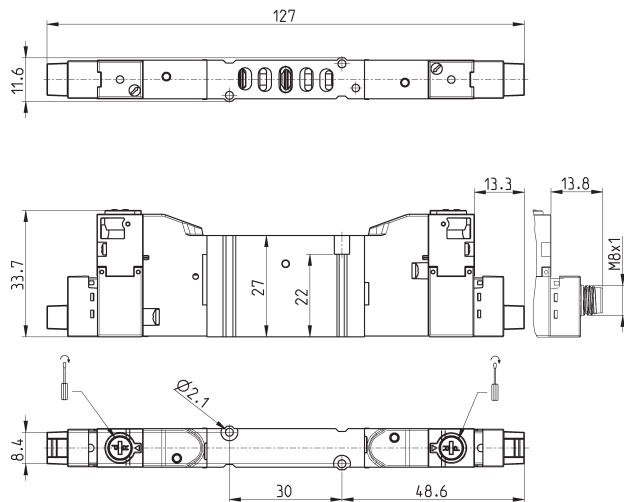
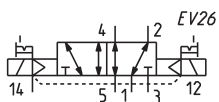

Mod.	Pilot supply pressure (bar)	Operating pressure (bar)	Flow (NL/min)	Symbol
D1EVB-BR / D1CVB-BR	2.5 ÷ 7	-0.9 ÷ 10	300	EV26

5/3-way solenoid valve, outlets on subbase - size 10.5



CC = Centres Closed
 CO = Centres Open
 CP = Centres Pressurized
 The indications given are valid for the versions D1EVB and D1CVB.
 The symbols of the versions with manual override type P are shown in the Appendix.

Connectors at the end of this section

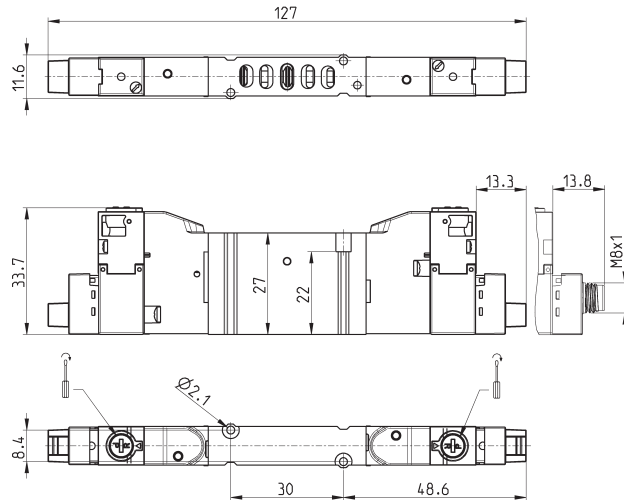
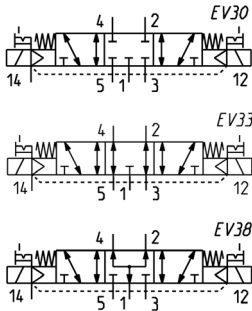

Mod.	Function	Pilot supply pressure (bar)	Operating pressure (bar)	Flow (NI/min)	Symbol
D1EVB-VR / D1CVB-VR	CC	2.5 ÷ 7	-0.9 ÷ 10	260	EV30
D1EVB-KR / D1CVB-KR	CO	2.5 ÷ 7	-0.9 ÷ 10	260	EV33
D1EVB-NR / D1CVB-NR	CP	2.5 ÷ 7	-0.9 ÷ 10	260	EV38

2x3/2-way solenoid valve, outlets on subbase - size 10.5



These solenoid valves integrate two 3/2-way functions - size 10.5.
 The indications given are valid for the versions D1EVA and D1CVA.
 The symbols of the versions with manual override type P are shown in the Appendix.

Connectors at the end of this section

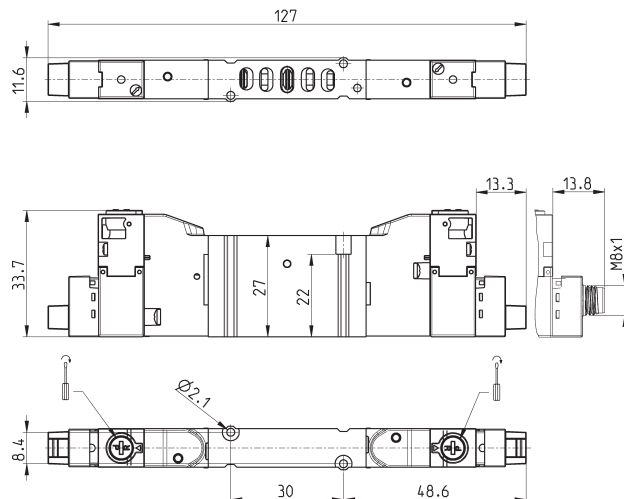
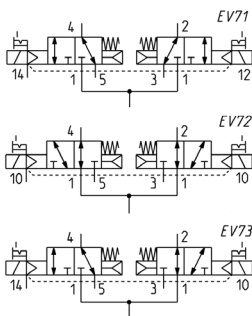

Mod.	Function	Pilot supply pressure (bar)	Operating pressure (bar)	Flow (NI/min)	Symbol
D1EVB-CR / D1CVB-CR	2 x 3/2 NC	2.5 ÷ 7	-0.9 ÷ 10	280	EV71
D1EVB-AR / D1CVB-AR	2 x 3/2 NO	2.5 ÷ 7	-0.9 ÷ 10	280	EV72
D1EVB-GR / D1CVB-GR	1 x 3/2 NC + 1 x 3/2 NO	2.5 ÷ 7	-0.9 ÷ 10	280	EV73

5/2-way solenoid valve, monostable, outlets on subbase - size 25



Connectors at the end of this section

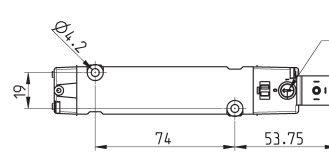
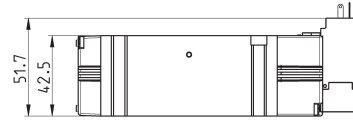
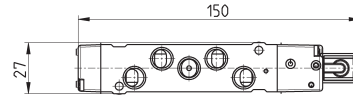
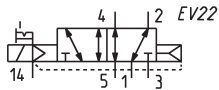

Mod.	Pilot supply pressure (bar)	Operating pressure (bar)	Flow (NL/min)	Symbol
D43VB-MR	2.5 ÷ 7	-0.9 ÷ 10	2000	EV22

5/2-way solenoid valve, bistable, outlets on subbase - size 25



Connectors at the end of this section

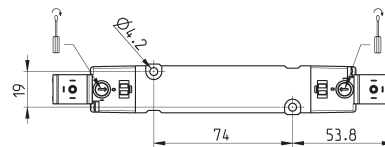
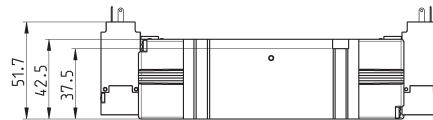
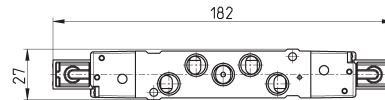
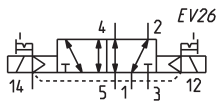

Mod.	Pilot supply pressure (bar)	Operating pressure (bar)	Flow (NL/min)	Symbol
D43VB-BR	2.5 ÷ 7	-0.9 ÷ 10	2000	EV26

5/3-way solenoid valve, outlets on subbase - size 25

CC = Centres Closed
CO = Centres Open
CP = Centres Pressurized

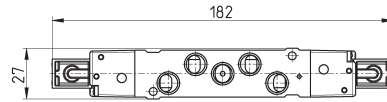

Connectors at the end of this section

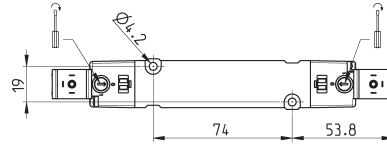
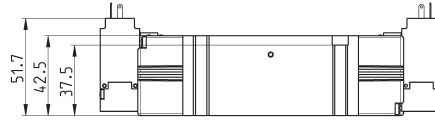
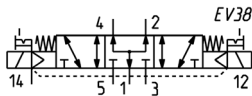
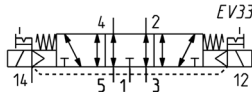
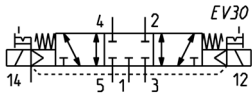

Mod.	Function	Pilot supply pressure (bar)	Operating pressure (bar)	Flow (NL/min)	Symbol
D43VB-VR	CC	2.5 ÷ 7	-0.9 ÷ 10	1800	EV30
D43VB-KR	CO	2.5 ÷ 7	-0.9 ÷ 10	1800	EV33
D43VB-NR	CP	2.5 ÷ 7	-0.9 ÷ 10	1800	EV38

2x3/2-way solenoid valve, outlets on subbase - size 25

Solenoid valves available in versions with 2x3/2-way valves on the same valve body

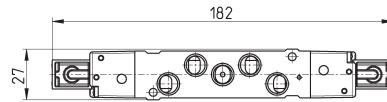

Connectors at the end of this section

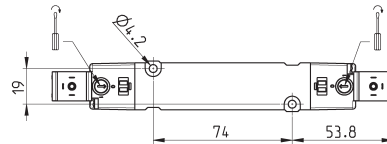
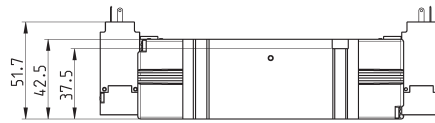
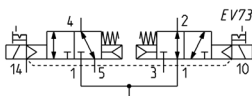
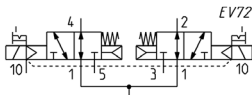
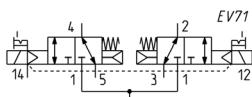

Mod.	Function	Pilot supply pressure (bar)	Operating pressure (bar)	Flow (NL/min)	Symbol
D43VB-CR	2x3/2NC	2.5 ÷ 7	-0.7 ÷ 10	1800	EV71
D43VB-AR	2x3/2NO	2.5 ÷ 7	-0.7 ÷ 10	1800	EV72
D43VB-GR	1 x 3/2 NC + 1 x 3/2 NO	2.5 ÷ 7	-0.7 ÷ 10	1800	EV73

CODING EXAMPLE

DC	B	1	0	-	12
-----------	----------	----------	----------	----------	-----------

DC	SERIES
B	MANIFOLD: B = For type VB valves
1	SIZE 1 = SIZE 10.5 4 = SIZE 25
0	SERVOPILOT: 0 = Kit included for internal/external servopilot
12	N° OF POSITIONS: 2 3 4 ... 19

Manifolds for valves model VB, Size 10,5

SERIES D VALVES AND SOLENOID VALVES

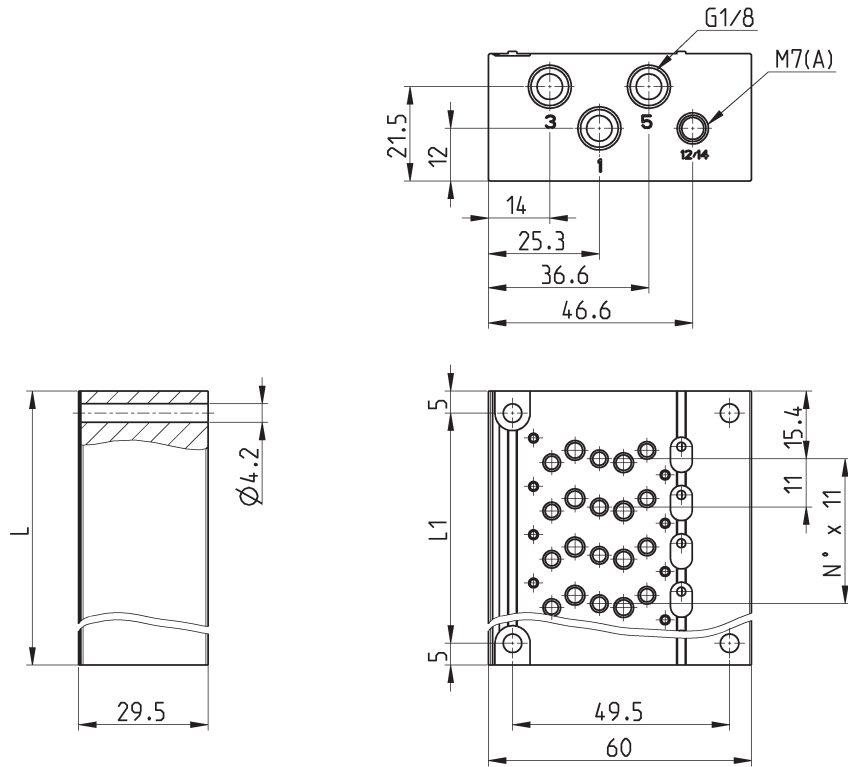

DIMENSIONS			
Mod.	Nr positions	L	L1
DCB10-2	2	11	21
DCB10-3	3	22	32
DCB10-4	4	33	43
DCB10-5	5	44	54
DCB10-6	6	55	65
DCB10-7	7	66	76
DCB10-8	8	77	87
DCB10-9	9	88	98
DCB10-10	10	99	109
DCB10-11	11	110	120
DCB10-12	12	121	131
DCB10-13	13	132	142
DCB10-14	14	143	153
DCB10-15	15	154	164
DCB10-16	16	165	175
DCB10-17	17	176	186
DCB10-18	18	187	197
DCB10-19	19	198	208

Manifold per valvole VB - passo 25

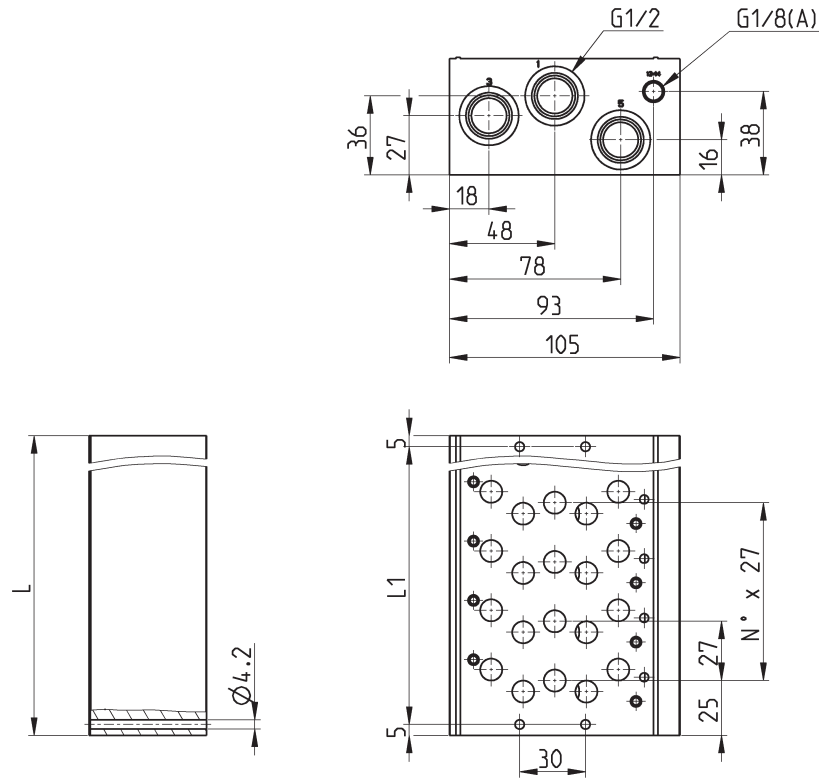

DIMENSIONS			
Mod.	Nr positions	L	L1
DCB40-2	2	89	27
DCB40-3	3	116	54
DCB40-4	4	143	81
DCB40-5	5	170	108
DCB40-6	6	197	135
DCB40-7	7	224	162
DCB40-8	8	251	89
DCB40-9	9	278	216
DCB40-10	10	305	243
DCB40-11	11	332	270
DCB40-12	12	359	297
DCB40-13	13	386	324
DCB40-14	14	413	351
DCB40-15	15	440	378
DCB40-16	16	467	405

CODING EXAMPLE MANIFOLD WITH VALVES AND FITTINGS

DC	B	1	E	R	A	-	MBMXCVB	-	3BX2AB	-	CSL	-	R
-----------	----------	----------	----------	----------	----------	---	----------------	---	---------------	---	------------	---	----------

DC	SERIES	
B	MANIFOLD WITH VALVES B = For type VB valve	
1	SIZE 1 = SIZE 10,5 4 = SIZE 25	
E	ACTUATION E = Electric C = Electric with M8 connector (D1) 3 = Electric with solenoid 15 mm (D4)	
R	TYPE OF MANUAL OVERRIDE: P = push button (not for D4) R = with push and turn device	
A	SERVOPILOT A = internal B = external	
MBMXCVB	TYPE OF VALVE / SOLENOID VALVE M = 5/2 Monostable B = 5/2 Bistable C = 2 x 3/2 NC A = 2 x 3/2 NO G = 2 x 3/2 (NC + NO) V = 5/3 CC K = 5/3 CO N = 5/3 CP L = Free position X = Additional supply and exhaust Y = Additional supply and exhaust with silencer	
3BX2AB	CONNECTIONS ON VALVE POSITIONS T = Thread A = Fittings Ø4 (D1) B = Fittings Ø6 (D1) C = Fittings Ø8 (D4) D = Fittings Ø10 (D4) E = Fittings Ø12 (D4) F = Fittings Ø14 (D4) L = Free position (code D1AVA-L) X = Additional supply and exhaust (code D1AVA-X) Y = Additional supply and exhaust with silencer (code D1AVA-Y)	
CSL	MANIFOLD CONNECTIONS T = Thread C (CS) = Fittings Ø 8 (D1), 6512 8-1/8-M (Silnecer 2931 1/8) D (DS) = Fittings Ø 10 (D1), 6512 10-1/8-M (Silnecer 2931 1/8) E (ES) = Fittings Ø 12 (D4), S6510 12-1/2 (Silnecer 2931 1/2) F (FS) = Fittings Ø 14 (D4), S6510 14-1/2 (Silnecer 2931 1/2) G (GS) = Fittings Ø 16 (D4), S6510 16-1/2 (Silnecer 2931 1/2) CONNECTION SIDE = both L = left (right closed) R = right (left closed)	(.S) Version with silencer External servo fittings: Ø6 (D1) 6512 6 - M7 - M Ø8 (D4) S6510 8 -1/8
R	FIXING: = DIRECT R = PORT FOR DIN RAIL	

Manifold with solenoid valves, outlets on subbase - size 10,5

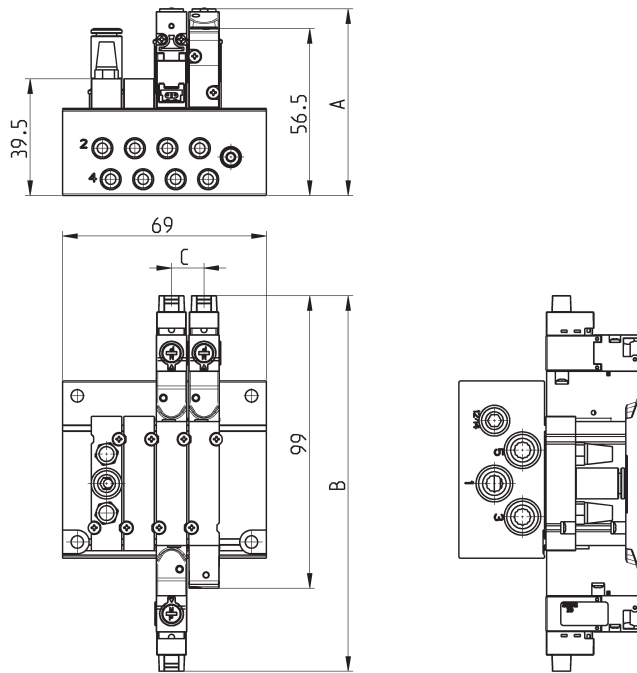

DIMENSIONS			
Mod.	A	B	C
DCA1ERA-	63	127.2	11
DCA1CRA-	63	128.2	11

Manifold with solenoid valves, outlets on base - size 25

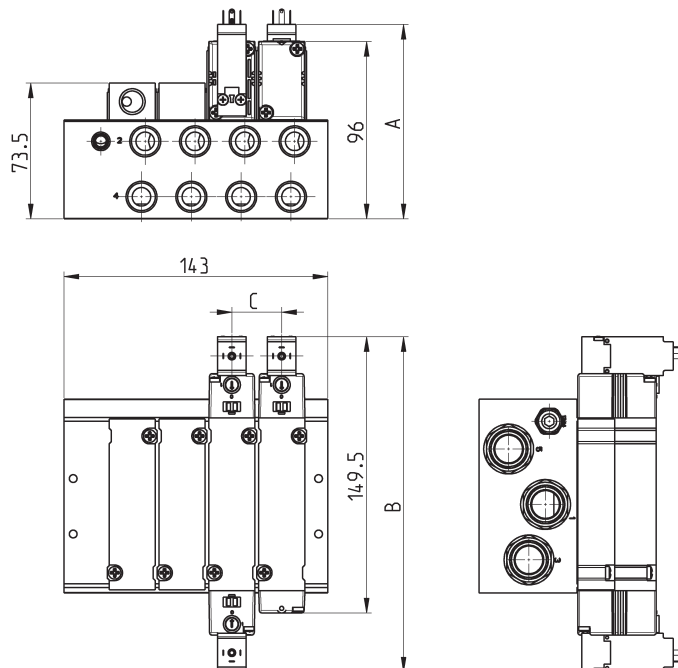

DIMENSIONS			
Mod.	A	B	C
DCA43RA-	105	181.5	27

Mounting brackets for DIN rail



DIN EN 50022 (7,5mm x 35mm - width 1)
Suitable for all manifolds.

Supplied with:
2x plates
2x screws M4x6 UNI 5931

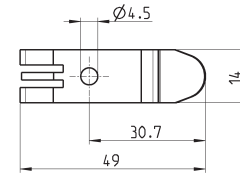

Mod.
PCF-E520

Blanking plate for manifolds - free position L

The following is supplied:
1x plate
2x screws
1x seal.

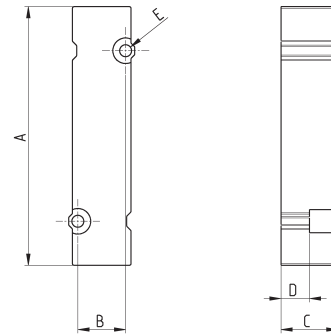

DIMENSIONS						
Mod.	Size	A	B	C	D	$\varnothing E$
D1AVB-L	10.5	45.5	8.4	10	5	2.1
D4AVB-L	25	92.5	19	20	5	4.2

Module X for additional supply and exhaust for size 10,5

The following is supplied:
1x plate
2x screws
1x seal.
1x fitting 6512 6-M7

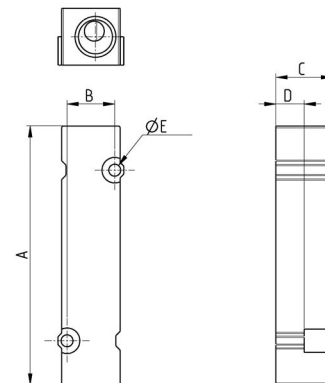
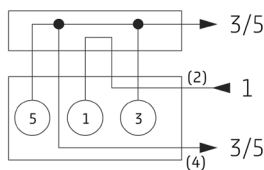

DIMENSIONS						
Mod.	Size	A	B	C	D	$\varnothing E$
D1AVB-X	10.5	45	8.4	10	5	2.1

Module X for additional supply and exhaust for size 25

The following is supplied:
 1x plate
 2x screws
 1x seal.
 1x fittings 6512 12-G1/4

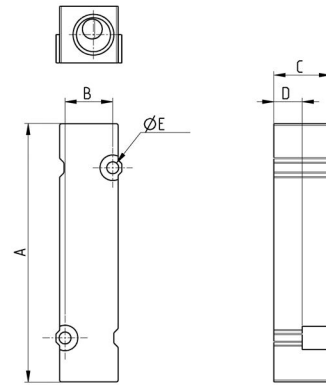
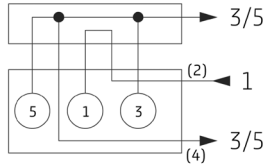

DIMENSIONS

Mod.	Size	A	B	C	D	ØE
D4AVB-X	25	65	19	20	20	4.2

Module Y for additional supply and exhaust with silencer for size 10,5

The following is supplied:
 1x plate
 2x screws
 1x seal.
 1x silencers 2931 M7

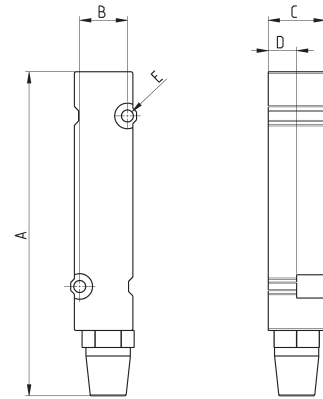
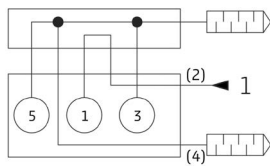

DIMENSIONS

Mod.	Size	A	B	C	D	ØE
D1AVB-Y	10.5	57	8.4	5	10	2.1

Module Y for additional supply and exhaust with silencer for size 25

The following is supplied:
 1x plate
 2x screws
 1x seal.
 2x silencers 2931 G1/4

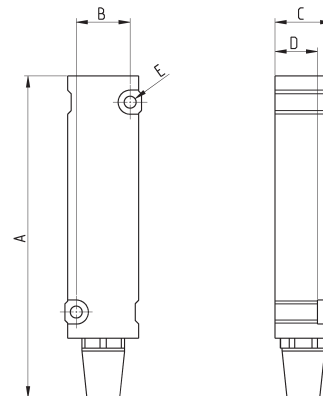
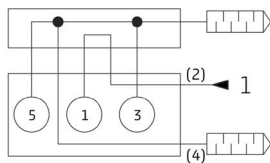

DIMENSIONS

Mod.	Size	A	B	C	D	ØE
D4AVB-Y	25	113.5	19	20	15	4.2

Connector Mod. 121-8..

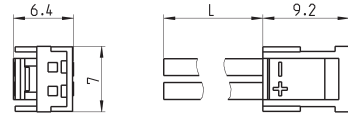

Mod.	description	colour	L = cable length (mm)	cable holding
121-803	crimped cable	black	300	crimping
121-806	crimped cable	black	600	crimping
121-810	crimped cable	black	1000	crimping
121-830	crimped cable	black	3000	crimping

3-wire extension with M8 3-pin female connector for "C" actuation



With PU sheathing, non shielded cable.
Protection class: IP65

- 1 BN = Brown
- 4 BK = Black
- 3 BU = Blue

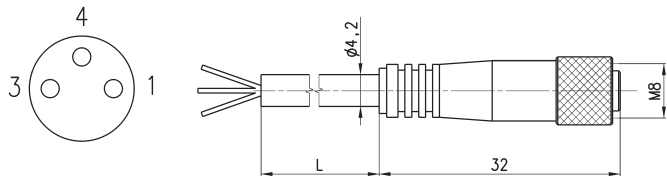

Mod.	L = cable length (m)
CS-2	2
CS-5	5
CS-10	10

3-wire extension with M8 3-pin male / female connector for "C" actuation

Non shielded

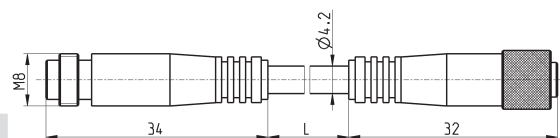
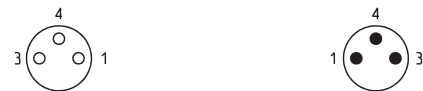

Mod.	cable length "L" (m)
CS-DW03HB-C250	2,5
CS-DW03HB-C500	5

Connector Mod. 125-... pitch 9.4 mm for "3" actuation

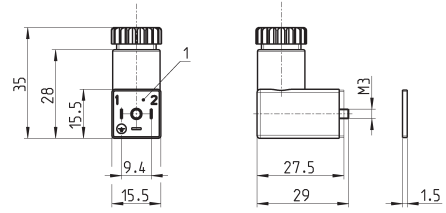

Mod.	description	colour	working voltage	cable holding	tightening torque
125-601	connector, diode + Led	transparent	10/50 V DC	PG7	0.3 Nm
125-701	connector, varistor + Led	transparent	24 V AC/DC	PG7	0.3 Nm
125-800	connector, without electronics	black	-	PG7	0.3 Nm

1 = 90° adjustable connector

Connector Mod. 125-... pitch 9.4 mm with cable for "C" actuation

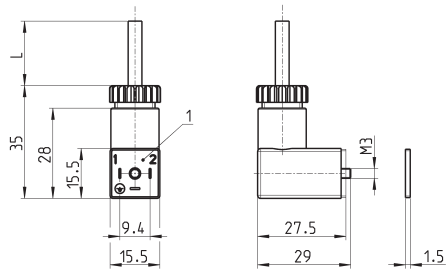

Mod.	description	colour	working voltage	cable length [L]	cable gland	tightening torque
125-501-2	moulded cable with diode + Led	black	10/50 V DC	2000 mm	-	0.3 Nm
125-550-1	moulded cable, without electronics	black	-	1000 mm	-	0.3 Nm

1 = 90° adjustable connector

In-line connectors with cable for "E" actuation

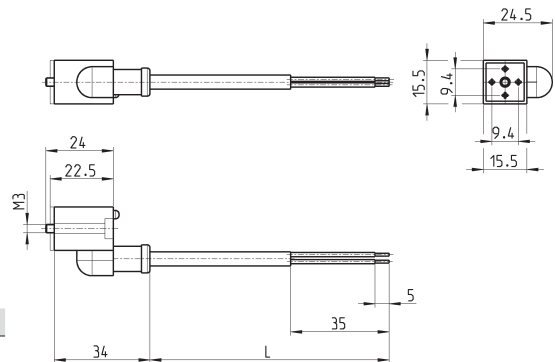

Mod.	description	colour	working voltage	cable length [L]	cable gland	tightening torque
125-503-2	in-line moulded cable, with diode + Led	black	24 V DC	2000 mm	-	0.3 Nm
125-503-5	in-line moulded cable, with diode + Led	black	24 V DC	5000 mm	-	0.3 Nm
125-553-2	in-line moulded cable, without electronics	black	-	2000 mm	-	0.3 Nm
125-553-5	in-line moulded cable, without electronics	black	-	5000 mm	-	0.3 Nm