

New

Proportional pressure regulator and proportional flow valve Series MX-PRO

Regulator and valve ports (Single and Manifold): G1/2
Regulator: with built-in pressure gauge or G1/8 threaded ports
Valve: without pressure gauge

SERIES MX-PRO PROPORTIONAL REGULATOR AND VALVE



Series MX-PRO electronic proportional pressure regulator is the result of combining advanced technology of Series K8P electronic proportional micro regulator, with reliability and high performance of Series MX2 modular regulators. This new regulator ensures high precision in pressure regulation, high flow rate and low consumption. Moreover, it can take the most of Series MX ease of assembly to provide particularly compact Manifolds.

- » High precision
- » Low electric consumption
- » High exhaust flow
- » Modular with Series MX
- » MANIFOLD and external servo pilot supply versions available
- » Compatible with oxygen

GENERAL DATA

	PROPORTIONAL PRESSURE REGULATOR	PROPORTIONAL FLOW VALVE
Construction	modular, compact, diaphragm type	modular, piston type
Materials	see material tables on the following pages	see material tables on the following pages
Ports	G1/2	G1/2
Mounting	vertical in-line, wall-mounting (by means of clamps)	vertical in-line, wall-mounting (by means of clamps)
Working pressure	0°C ÷ 50°C	0°C ÷ 50°C
Max inlet pressure	11 bar (10 bar), 4 bar (3 bar), 1.5 bar (1 bar), 8 bar (7 bar)	6 bar
Regulated pressure	0.5 ÷ 10 bar, 0.15 ÷ 3 bar, 0.05 ÷ 1 bar, 0.35 ÷ 7	-
Max servo-pilot pressure	4 bar (3 bar), 11 bar (10 bar), 1.5 bar (1 bar), 8 bar (7 bar)	4 bar (essential for the proper functioning)
Overpressure exhaust	with Relieving (standard) or without Relieving	NO
Nominal flow	see flow diagrams on the following pages	see flow diagrams on the following pages
Fluid	filtered compressed air, non lubricated, class 7.4.4 according to ISO 8573.1 standard. If lubrication is necessary, please use only oils with maximum viscosity of 32 Cst and the version with external servo-pilot supply. The servo-pilot supply air quality class must be 7.4.4 according to ISO 8573.1 standard.	filtered compressed air, non lubricated, class 7.4.4 according to ISO 8573.1 standard. If lubrication is necessary, please use only oils with maximum viscosity of 32 Cst and the version with external servo-pilot supply. The servo-pilot supply air quality class must be 7.4.4 according to ISO 8573.1 standard. Compatible to work with Oxygen.
Pressure gauge	with built-in pressure gauge (standard) with G1/8 port	without pressure gauge
Analogical input	0-10 V DC Ripple ≤ 0.2%; 4 – 20 mA	0-10 V DC Ripple ≤ 0.2%; 4 – 20 mA
Analogical output	0.5 - 9.5 V DC [Feedback]	not relevant
Electrical supply	24 V DC ±10%	24 V DC ±10%
Electrical connection	M8 4 Pin (Male)	M8 4 Pin (Male)
Linearity	≤ ± 1% FS	±5% FS
Hysteresis	0.5% FS	8% FS
Repeatability	±0.5% FS	±0.5% FS
Sensibility	0.3% FS	0.5% FS

CODING EXAMPLE

MX	2	-	1/2	-	R	CV	2	0	4	-	LH
-----------	----------	----------	------------	----------	----------	-----------	----------	----------	----------	----------	-----------

MX	SERIES
2	SIZE: 2 = G1/2
1/2	PORTS: 1/2 = G1/2
R	FUNCTIONING: R = pressure regulator M = Manifold pressure regulator V = flow valve W = Manifold flow valve
CV	COMMAND: CV = electrical command 0-10 V DC (regulator only) CA = electrical command 4-20 mA (regulator only) EV = electrical command 0-10 V DC with external servo pilot supply EA = electrical command 4-20 mA with external servo pilot supply
2	REGULATOR SETTING RANGE: 1 = working pressure 0.15 ÷ 3 bar 2 = working pressure 0.5 ÷ 10 bar 3 = working pressure 0.05 ÷ 1 bar 4 = working pressure 0.35 ÷ 7 bar VALVE SETTING RANGE: 7 = flow valve
0	DESIGN TYPE: 0 = relieving (regulator only) 1 = without relieving
4	PRESSURE GAUGE: 0 = without pressure gauge, with threaded port for gauges 2 = with built-in pressure gauge 0-6 bar (regulator only) 3 = with built-in pressure gauge 0-10 bar (regulator only) 4 = with built-in pressure gauge 0-12 bar (regulator only)
LH	FLOW DIRECTION: = from left to right (standard) LH = from right to left
OX1	= suitable for use with oxygen (V and W flow valve only)

Further details about the assembly of a single component with fixing flanges or wall-mounting can be found in the AIR TREATMENT catalogue, section SERIES MX ASSEMBLED FRL.

Series MX-PRO proportional pressure regulator - materials

R = proportional pressure regulator
M = Manifold proportional pressure regulator

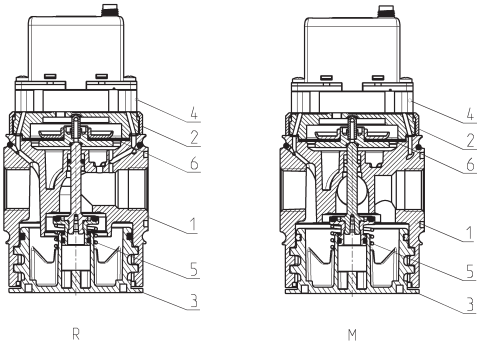

PARTS	MATERIALS, Single and manifold version
1 = Body	Aluminium
2 = Covering	Polyacetal
3 = Valve holder plug	Polyacetal
4 = Upper base	Polyamide
5 = Lower spring	Stainless steel
6 = Diaphragm	NBR
Seals	NBR

Series MX-PRO proportional flow valve - materials

V = proportional flow valve
W = Manifold proportional flow valve

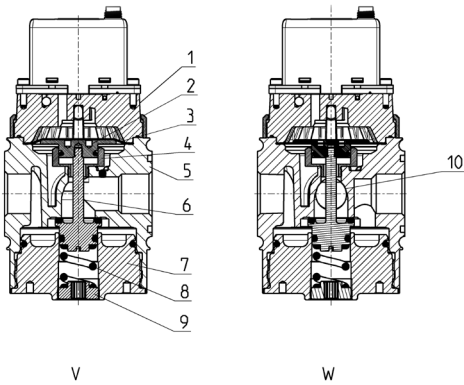

PARTS	MATERIALS, Single and Manifold version
1 = Upper base	Polyamide
2 = Piston	Brass
3 = Diaphragm	NBR
4 = Valve guide	Brass
5 = Body	Aluminium
6 = Poppet	Brass
7 = plug	Anodised aluminium
8 = spring	Steel
9 = spring guide	Brass
10 = Manifold output connection	nickel-plated brass
Seals	FKM/NBR

Series MX-PRO proportional pressure regulator - Single version



Male connector M8 4 poles
 Pin 1: +24 V DC (Power supply)
 Pin 2: Command analogical signal
 0-10 V DC or 4-20 mA
 Pin 3: 0 V (Ground) common also for
 the command signal
 Pin 4: Output analogical signal
 (according to the regulated
 pressure)

5 red LED
 6 green LED

DRAWING NOTE:
 ** = in the versions with external servo pilot
 supply only (MX2-1/2-REV... and MX2-1/2-REA...)

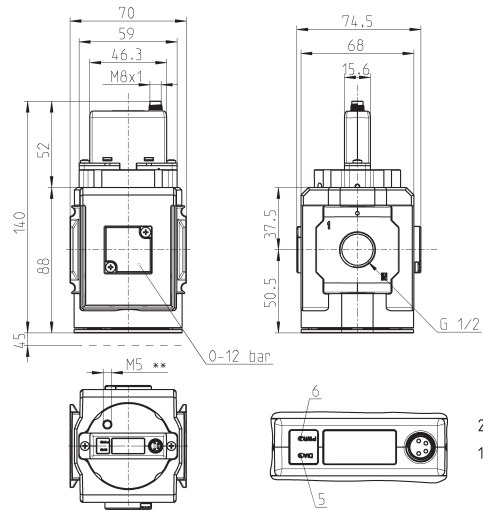

Mod.	Electrical command	Setting range	Pressure gauge
MX2-1/2-R*V1#0	0-10 V DC	0.15 ÷ 3 bar	without pressure gauge
MX2-1/2-R*V1#2	0-10 V DC	0.15 ÷ 3 bar	with built-in pressure gauge 0-6
MX2-1/2-R*V2#0	0-10 V DC	0.5 ÷ 10 bar	without pressure gauge
MX2-1/2-R*V2#4	0-10 V DC	0.5 ÷ 10 bar	with built-in pressure gauge 0-12
MX2-1/2-R*V3#0	0-10 V DC	0.05 ÷ 1 bar	without pressure gauge
MX2-1/2-R*V4#0	0-10 V DC	0.35 ÷ 7 bar	without pressure gauge
MX2-1/2-R*V4#3	0-10 V DC	0.35 ÷ 7 bar	with built-in pressure gauge 0-10
MX2-1/2-R*A1#0	4-20 mA	0.15 ÷ 3 bar	without pressure gauge
MX2-1/2-R*A1#2	4-20 mA	0.15 ÷ 3 bar	with built-in pressure gauge 0-6
MX2-1/2-R*A2#0	4-20 mA	0.5 ÷ 10 bar	without pressure gauge
MX2-1/2-R*A2#4	4-20 mA	0.5 ÷ 10 bar	with built-in pressure gauge 0-12
MX2-1/2-R*A3#0	4-20 mA	0.05 ÷ 1 bar	without pressure gauge
MX2-1/2-R*A4#0	4-20 mA	0.35 ÷ 7 bar	without pressure gauge
MX2-1/2-R*A4#3	4-20 mA	0.35 ÷ 7 bar	with built-in pressure gauge 0-10

TABLE NOTES:

* = versions with or without external pilot supply

= versions with or without relieving

LH = add LH at the end of the code for air inlet from the right to the left

PRESSURE REGULATOR FLOW DIAGRAMS - SINGLE VERSION

SERIES MX-PRO PROPORTIONAL REGULATOR AND VALVE

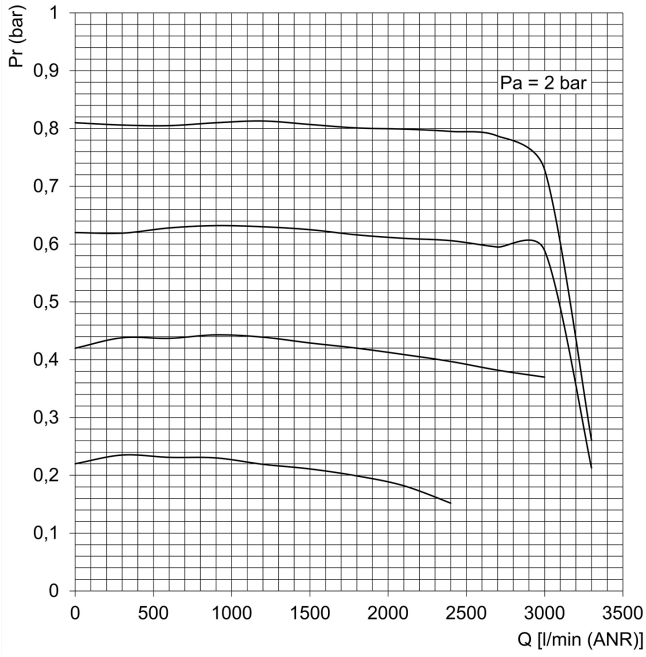

Pr = Regulated pressure
Q = Flow
Pa = Inlet pressure

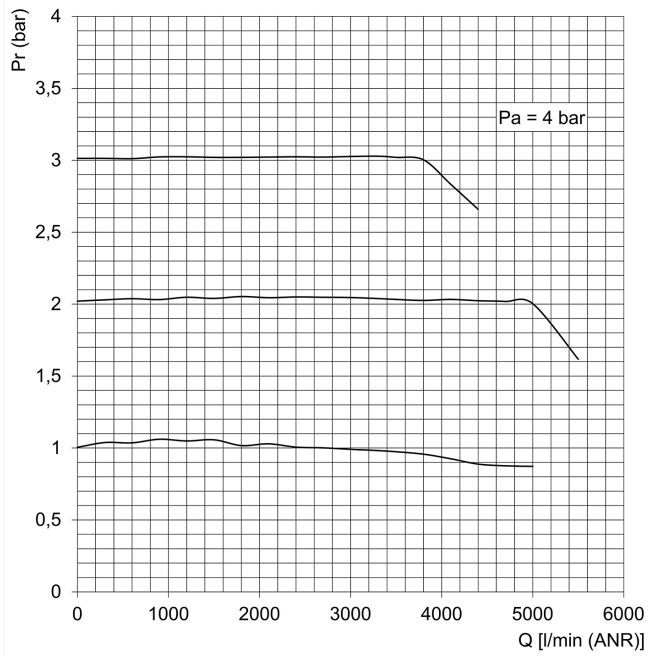

Pr = Regulated pressure
Q = Flow
Pa = Inlet pressure

PRESSURE REGULATOR FLOW DIAGRAMS - SINGLE VERSION

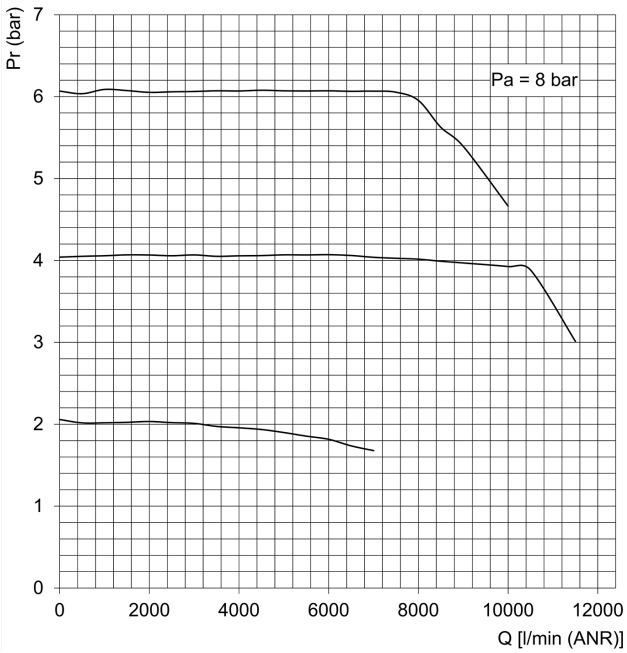

Pr = Regulated pressure
Q = Flow
Pa = Inlet pressure

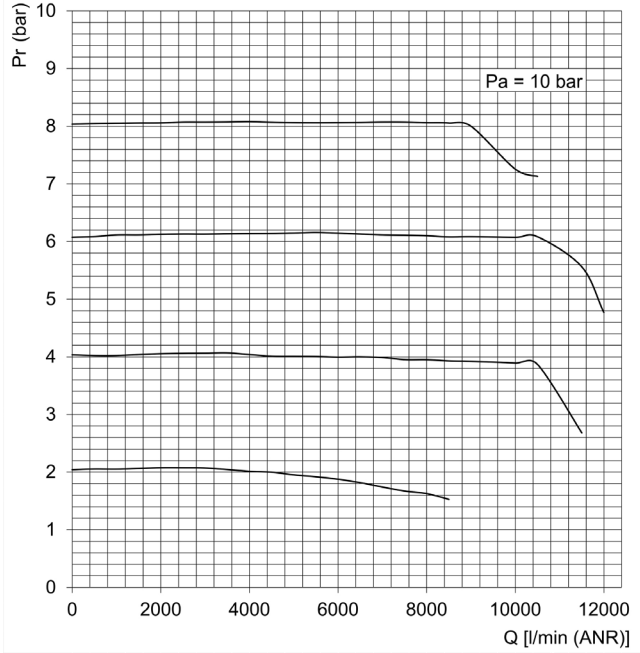

Pr = Regulated pressure
Q = Flow
Pa = Inlet pressure

EXHAUST FLOW DIAGRAM AND PNEUMATIC SYMBOLS - SINGLE VERSION

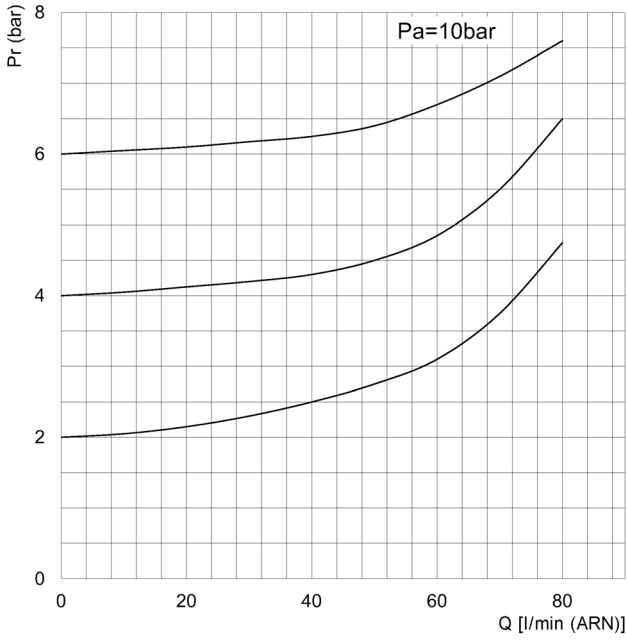

Pr = Regulated pressure
 Q = Flow
 Pa = Inlet pressure

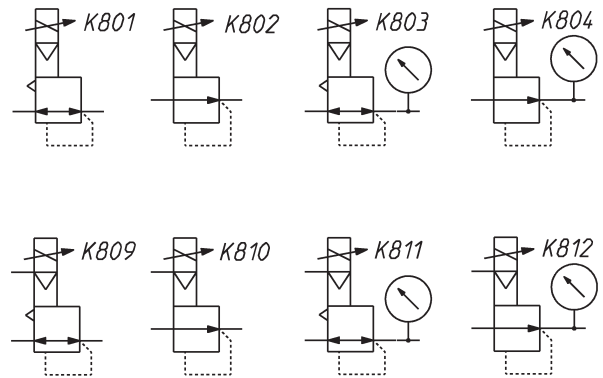

- K801 = relieving, electrical command
- K802 = NO relieving, electrical command
- K803 = relieving, electrical command, built-in pressure gauge
- K804 = NO relieving, electrical command, built-in pressure gauge
- K809 = relieving, electrical command, ext. servo pilot supply
- K810 = NO reliev., electrical command, ext. servo pilot supply
- K811 = reliev., el. com., built-in pr. gauge, ext. servo pilot supply
- K812 = NO reliev., el. com., built-in pr. gauge, ext. servo pilot sup.

Series MX-PRO proportional pressure regulator - Manifold version



Male connector M8 4 poles
 Pin 1: +24 V DC (Power supply)
 Pin 2: Command analogical signal
 0-10 V DC or 4-20 mA
 Pin 3: 0 V (Ground) common also for
 the command signal
 Pin 4: Output analogical signal
 (according to the regulated
 pressure)

5 red LED
 6 green LED

DRAWING NOTE:
 ** = in the versions with external servo pilot
 supply only (MX2-1/2-REV... and MX2-1/2-REA...)

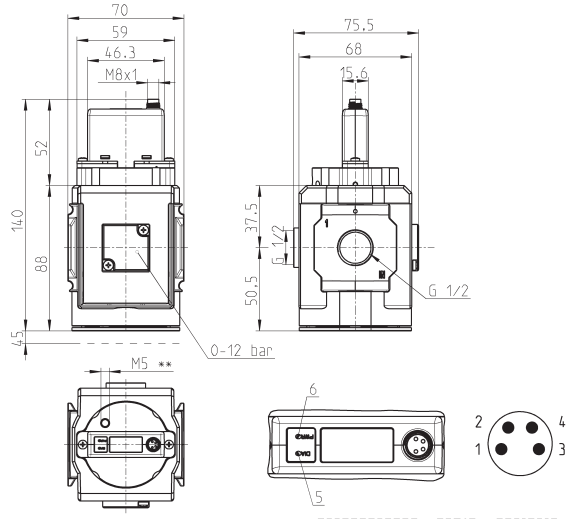

Mod.	Electrical command	Setting range	Pressure gauge
MX2-1/2-M*V1#0	0-10 V DC	0.15 ÷ 3 bar	without pressure gauge
MX2-1/2-M*V1#2	0-10 V DC	0.15 ÷ 3 bar	with built-in pressure gauge 0-6
MX2-1/2-M*V2#0	0-10 V DC	0.5 ÷ 10 bar	without pressure gauge
MX2-1/2-M*V2#4	0-10 V DC	0.5 ÷ 10 bar	with built-in pressure gauge 0-12
MX2-1/2-M*V3#0	0-10 V DC	0.05 ÷ 1 bar	without pressure gauge
MX2-1/2-M*V4#0	0-10 V DC	0.35 ÷ 7 bar	without pressure gauge
MX2-1/2-M*A1#0	4-20 mA	0.15 ÷ 3 bar	without pressure gauge
MX2-1/2-M*A1#2	4-20 mA	0.15 ÷ 3 bar	with built-in pressure gauge 0-6
MX2-1/2-M*A2#0	4-20 mA	0.5 ÷ 10 bar	without pressure gauge
MX2-1/2-M*A2#4	4-20 mA	0.5 ÷ 10 bar	with built-in pressure gauge 0-12
MX2-1/2-M*A3#0	4-20 mA	0.05 ÷ 1 bar	without pressure gauge
MX2-1/2-M*A4#0	4-20 mA	0.35 ÷ 7 bar	without pressure gauge
MX2-1/2-M*A4#3	4-20 mA	0.35 ÷ 7 bar	with built-in pressure gauge 0-10

TABLE NOTES:

* = versions with or without external pilot supply

= versions with or without relieving

LH = add LH at the end of the code for air inlet from the right to the left

PRESSURE REGULATOR FLOW DIAGRAMS - MANIFOLD VERSION

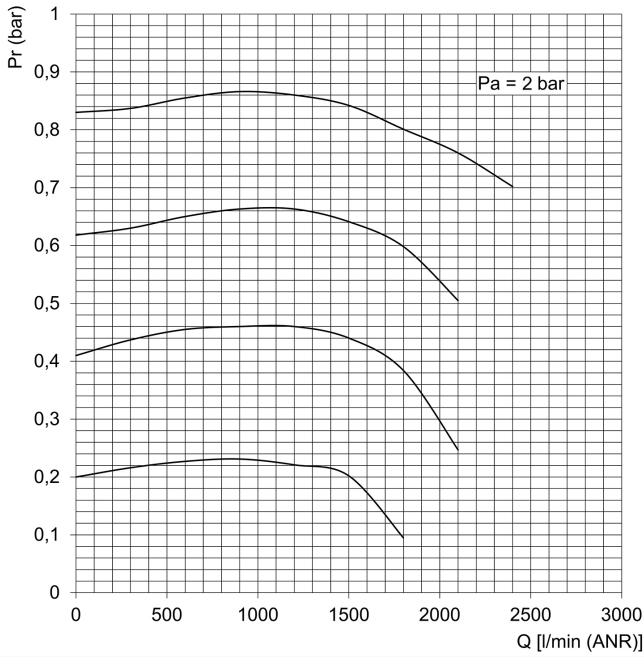

Pr = Regulated pressure
 Q = Flow
 Pa = Inlet pressure

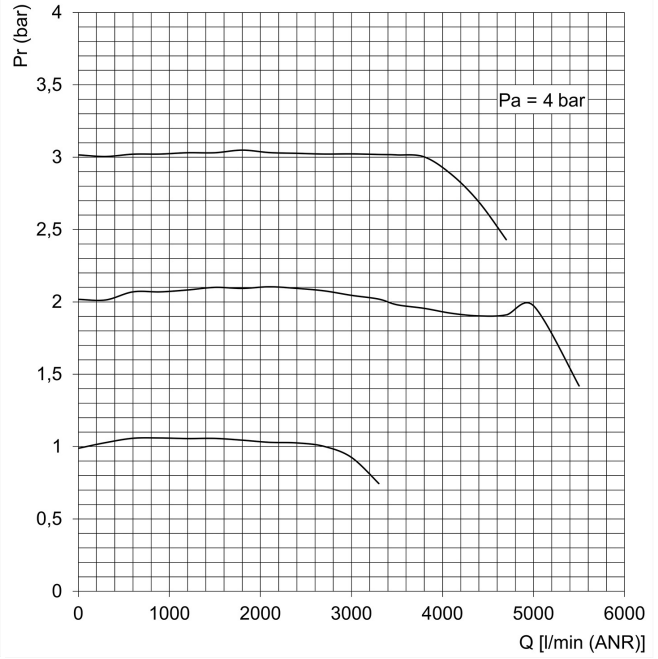

Pr = Regulated pressure
 Q = Flow
 Pa = Inlet pressure

SERIES MX-PRO PROPORTIONAL REGULATOR AND VALVE

PRESSURE REGULATOR FLOW DIAGRAMS - MANIFOLD VERSION

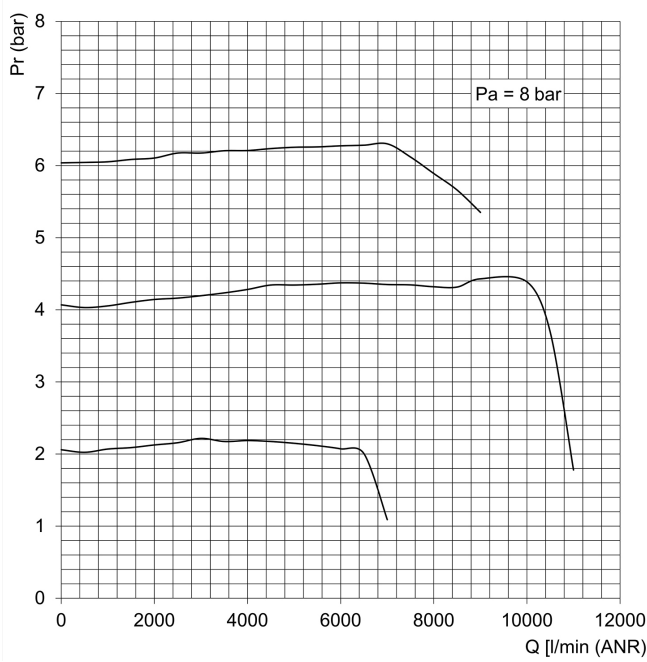

Pr = Regulated pressure
 Q = Flow
 Pa = Inlet pressure

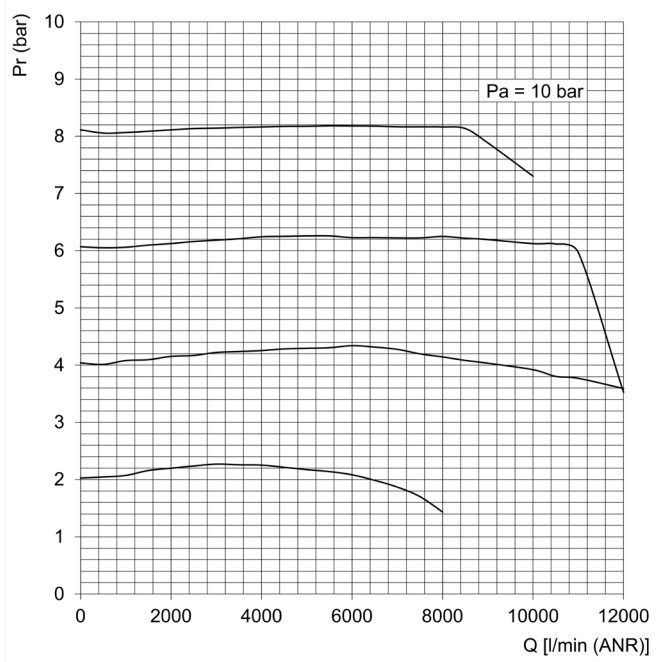

Pr = Regulated pressure
 Q = Flow
 Pa = Inlet pressure

EXHAUST FLOW DIAGRAM - MANIFOLD VERSION

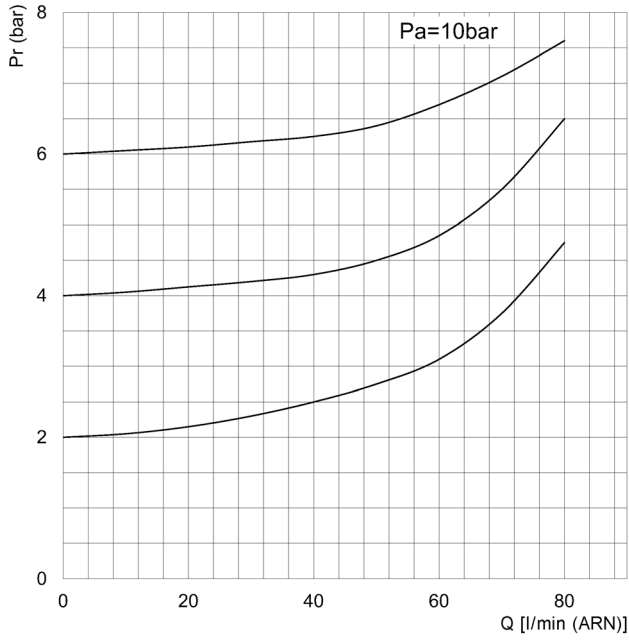

Pr = Regulated pressure
Q = Flow
Pa = Inlet pressure

PNEUMATIC SYMBOLS - MANIFOLD VERSION

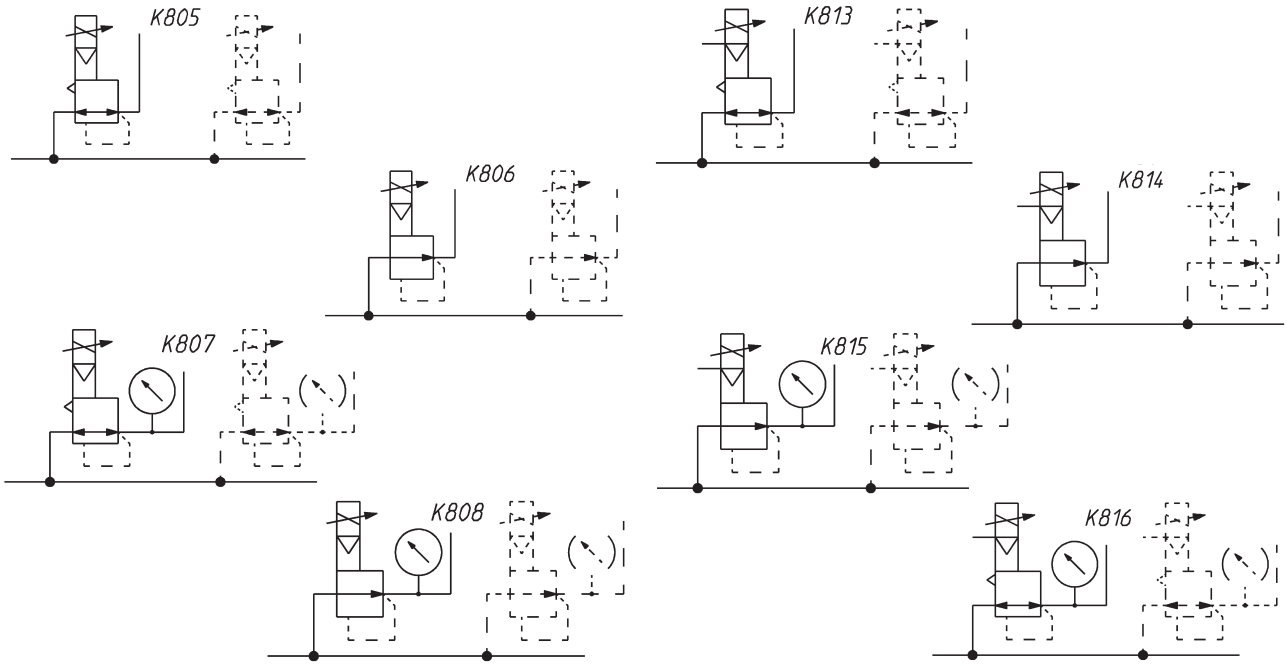

K805 = MANIFOLD reg., relieving, electrical command
K806 = MANIFOLD reg., NO relieving, electrical command
K807 = MANIFOLD reg., relieving, electrical command and built-in pressure gauge
K808 = MANIFOLD reg., NO relieving, electrical command and built-in pressure gauge

K813 = MANIFOLD reg., relieving, electrical command, and external servo pilot supply
K814 = MANIFOLD reg., NO relieving, electrical command, and external servo pilot supply
K815 = MANIFOLD reg., relieving, electrical command, built-in pressure gauge and external servo pilot supply
K816 = MANIFOLD reg., NO relieving, electrical command, built-in pressure gauge and external servo pilot supply

Series MX-PRO proportional flow valve - Single version



- Male connector M8 4 poles
- Pin 1: +24 V DC (Power supply)
- Pin 2: Command analogical signal
0-10 V DC or 4-20 mA
- Pin 3: 0 V (Ground) common also
for the command signal
- Pin 4: Output analogical signal
(according to the
regulated pressure)
- 5 red LED
- 6 green LED

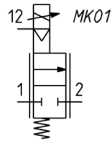
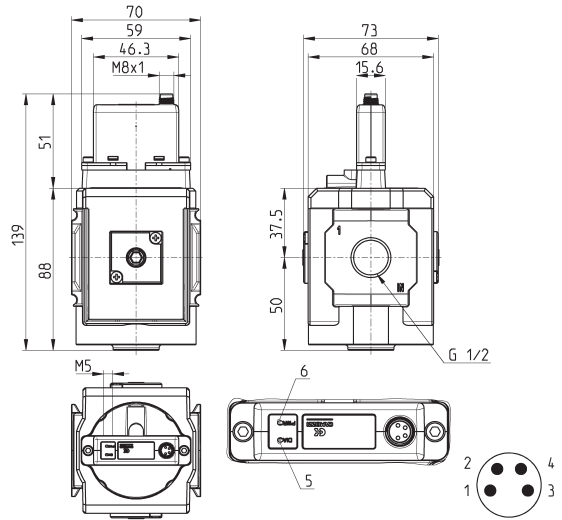

Mod.	Electrical command	Setting range
MX2-1/2-VEV710	0-10 V DC	0-6500 l/min (ARN)
MX2-1/2-VEA710	4-20 mA	0-6500 l/min (ARN)
MX2-1/2-VEV710-LH	0-10 V DC	0-6500 l/min (ARN)
MX2-1/2-VEA710-LH	4-20 mA	0-6500 l/min (ARN)
MX2-1/2-VEV7100X1	0-10 V DC	0-6500 l/min (ARN)
MX2-1/2-VEA7100X1	4-20 mA	0-6500 l/min (ARN)
MX2-1/2-VEV710-LHOX1	0-10 V DC	0-6500 l/min (ARN)
MX2-1/2-VEA710-LHOX1	4-20 mA	0-6500 l/min (ARN)

VALVE FLOW DIAGRAMS - SINGLE VERSION

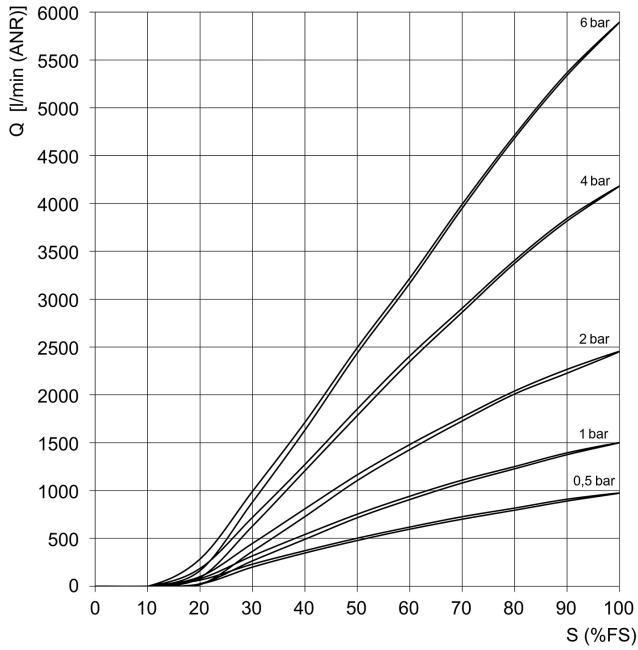

Q = flow
S = full scale command signal

SERIES MX-PRO PROPORTIONAL REGULATOR AND VALVE

Valve maximum flow and response times - Single version

Maximum flow according to the inlet pressure

DIAGRAM LEGEND:

Q = flow
P = inlet pressure

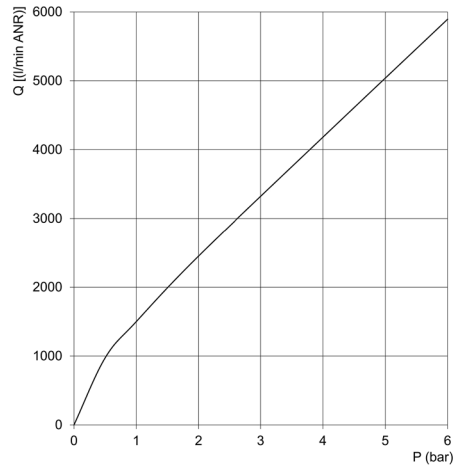

RESPONSE TIME measured with the maximum flow at the operating pressure [Elettromechanical response time: 90 ms]

Pin (bar)	Opening response time [ms]		Closing response time [ms]	
	0%-10%	10%-90%	100%-90%	100%-10%
6	117	266	106	553

Series MX-PRO Manifold proportional flow valve - Manifold version



- Male connector M8 4 poles
- Pin 1: +24 V DC (Power supply)
- Pin 2: Command analogical signal
0-10 V DC or 4-20 mA
- Pin 3: 0 V (Ground) common also
for the command signal
- Pin 4: Output analogical signal
(according to the
regulated pressure)
- 5 red LED
- 6 green LED

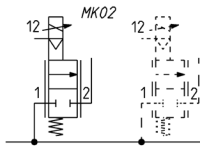
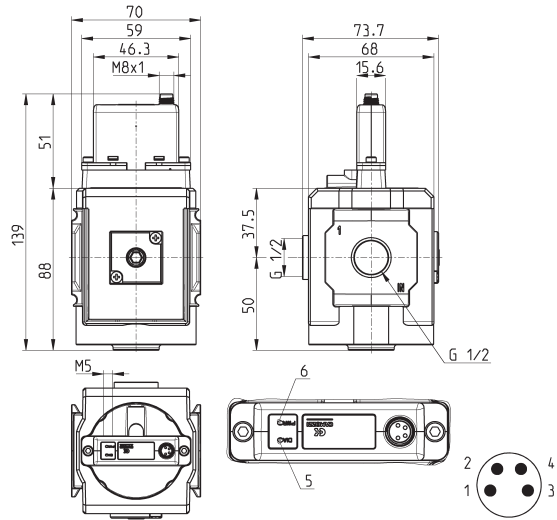

Mod.	Electrical command	Setting range
MX2-1/2-WEV710	0-10 V DC	0-6100 l/min (ANR)
MX2-1/2-WEA710	4-20 mA	0-6100 l/min (ANR)
MX2-1/2-WEV710-LH	0-10 V DC	0-6100 l/min (ANR)
MX2-1/2-WEA710-LH	4-20 mA	0-6100 l/min (ANR)
MX2-1/2-WEV710OX1	0-10 V DC	0-6100 l/min (ARN)
MX2-1/2-WEA710OX1	4-20 mA	0-6100 l/min (ARN)
MX2-1/2-WEV710-LHOX1	0-10 V DC	0-6100 l/min (ARN)
MX2-1/2-WEA710-LHOX1	4-20 mA	0-6100 l/min (ARN)

VALVE FLOW DIAGRAMS - MANIFOLD VERSION

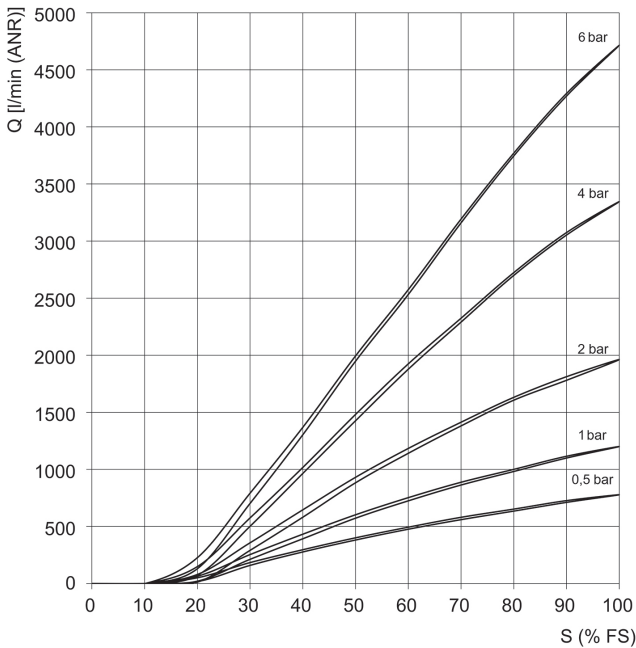

Low flow version

Q = flow
S = full scale command signal

DECAY FACTOR - MANIFOLD VERSION

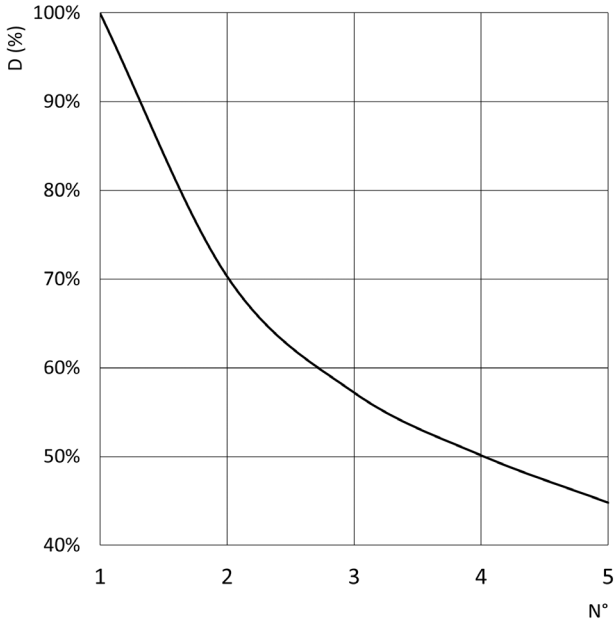

N° = number of valves in manifold configuration
 D(%) = relative percentage decay of the maximum flow rate
 Note: the air inlet is only from one side, in case it should be on the right and on the left, only consider the positions as from 1 ÷ 3.

Valve maximum flow and response times - Manifold version

Maximum flow according to the inlet pressure

DIAGRAM LEGEND:

Q = flow
 P = inlet pressure

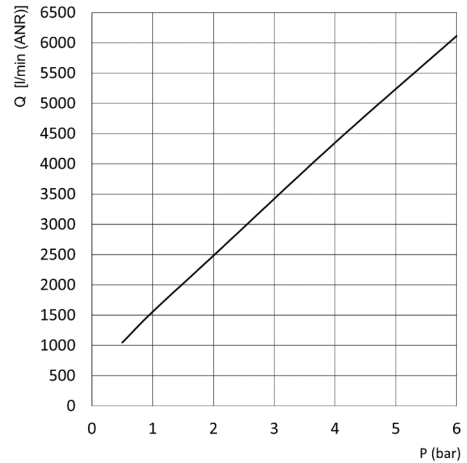

RESPONSE TIME measured with the maximum flow at the operating pressure [Electromechanical response time: 90 ms]

Pin (bar)	Opening response time [ms]		Closing response time [ms]	
	0%-10%	10%-90%	100%-90%	100%-10%
6	130	296	116	605

Rapid clamp kit



The kit MX2-X is supplied with:
 1 rapid clamp, 1 O-ring OR 3125 *,
 2 exagonal nuts M5, 2 screws M5x69.

The kit MX2-Z is supplied with:
 1 rapid clamp, 1 O-ring OR 3125 *,
 1 exagonal nut M5, 1 screw M5x69,
 1 screw M5x85 for wall fixing.

* it can be ordered separately (cod. 160-39-11/19)

Materials: technopolymer clamp, NBR O-ring,
 zinc-plated steel nuts and screws.

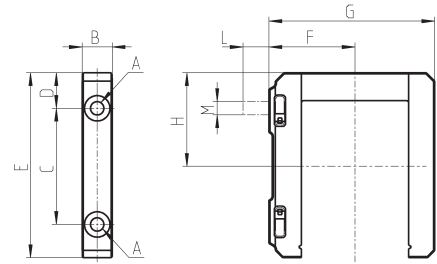

DIMENSIONS											
Mod.	A	B	C	D	E	F	G	H	L	M	Notes
MX2-X	5.2	12	46	14	73.5	37.5	70.5	37	-	-	
MX2-Z	5.2	12	46	14	73.5	37.5	70.5	37	14	M5	kit with wall fixing screw

Rapid clamp kit with wall fixing brackets



The kit MX2-Y is supplied with:
 1 wall rapid clamp, 1 O-ring OR 3125 **, 2 exagonal nuts, 2 screws M5x69.

** it can be separately ordered (cod. 160-39-11/19)

Materials: technopolymer clamp, NBR O-ring,
 zinc-plated steel nuts and screws.

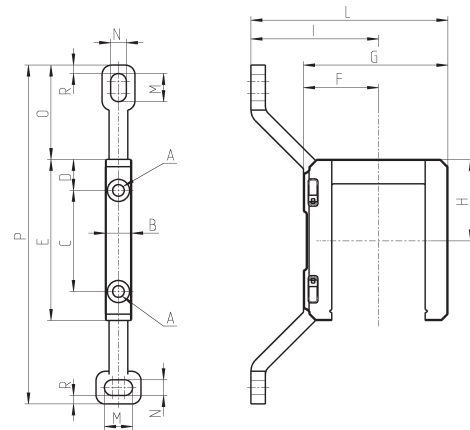

Mod.	A	B	C	D	E	F	G	H	I	L	M	N	O	P	R
MX2-Y	5,2	12	46	14	73,5	32,5	70,5	37	70,5	103	12	6,5	42	152	4

Terminal flanges (IN/OUT)

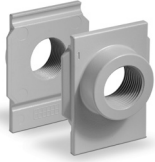

The kit is supplied with:
- 1 flange INLET side
- 1 flange OUTLET side

Materials: painted aluminium flanges.

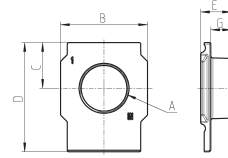

Mod.	A	B	C	D	E	G
MX2-1/2-FL	G1/2	50	26,5	63,5	17	11

Rapid clamps kit + flanges



Mod.	The kit is supplied with:
MX2-1/2-HH	1x MX2-1/2-FL + 2x MX2-X
MX2-1/2-JJ	1x MX2-1/2-FL + 2x MX2-Z

Rapid clamps kit with wall fixing brackets + flanges

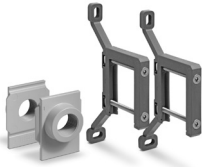

Mod.	The kit is supplied with:
MX2-1/2-KK	1x MX2-1/2-FL + 2x MX2-Y

Block for pressure gauge fixing



The kit is supplied with:
1 block
1 grain
2 screws
1 seal

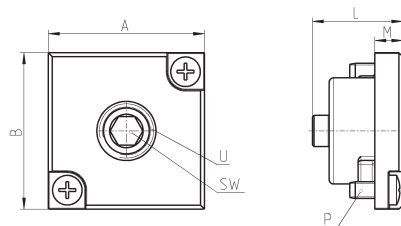

DIMENSIONS							
Mod.	A	B	L	M	P	U	SW
MX2-R26/1-P	28	28	16.5	5	M3X7	1/8	5

O-ring for assembling

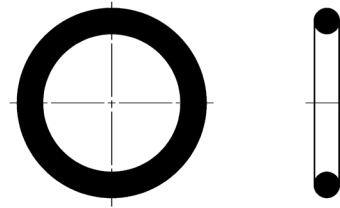

Mod.	O-ring	For assembly
160-39-11/19	OR 3125	MX2

Circular M8 4-pole connectors, Female

With PU sheathing, non shielded cable.
Protection class: IP65

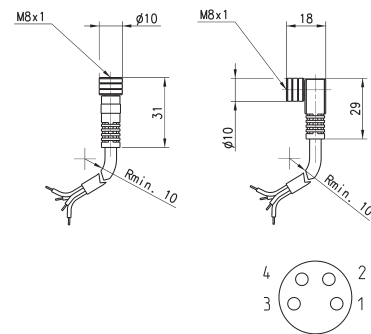

Mod.	Type of connector	Cable length (m)
CS-DF04EG-E200	straight	2
CS-DF04EG-E500	straight	5
CS-DR04EG-E200	right angle (90 degrees)	2
CS-DR04EG-E500	right angle (90 degrees)	5

Pressure gauges with rear connection

Precision class CL1,6

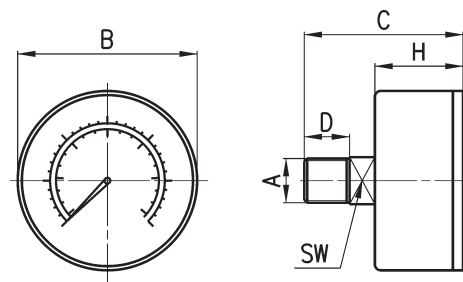

DIMENSIONS							
Mod.	A	B	C	D	H	SW	Range
M043-P02,5	R1/8	$\phi 38.8$	41	10	25	14	0 ÷ 2.5 bar
M043-P04	R1/8	$\phi 38.8$	41	10	25	14	0 ÷ 4 bar
M043-P06	R1/8	$\phi 38.8$	41	10	25	14	0 ÷ 6 bar
M043-P10	R1/8	$\phi 38.8$	41	10	25	14	0 ÷ 10 bar
M043-P12	R1/8	$\phi 38.8$	41	10	25	14	0 ÷ 12 bar
M053-P04	R1/8	$\phi 50$	41.5	10	25	14	0 ÷ 4 bar
M053-P06	R1/8	$\phi 50$	41.5	10	25	14	0 ÷ 6 bar
M053-P10	R1/8	$\phi 50$	41.5	10	25	14	0 ÷ 10 bar
M053-P12	R1/8	$\phi 50$	41.5	10	25	14	0 ÷ 12 bar