

Series MC pressure regulators

Ports G1/4, G3/8 and G1/2
Modular



- » Minimal pressure decreases
- » Lockable knob with closure
- » Integral return exhaust (relieving)
- » Versions available: with by-pass valve or Manifold

Series MC pressure regulators are available with ports G1/4, G3/8 and G1/2. Versions with secondary pressure relieving are usually available and all regulators can be panel mounted.

GENERAL DATA

Construction	modular, compact, diaphragm type		
Materials	zama, brass, NBR, technopolymer		
Ports	G1/4	G3/8	G1/2
Weight	kg	0,323	0,644 0,624
Mounting	in-line, wall or panel mounting (in any position)		
Operating temperature	-5°C ÷ 50°C (with the dew point of the fluid lower than 2°C at the min. working temperature)		
Finishing	enamelled		
Inlet pressure	0 ÷ 16 bar		
Outlet pressure	0.5 ÷ 10 bar (standard) or 0 ÷ 2 bar; 0 ÷ 4 bar and 0.5 ÷ 7 bar		
Nominal flow	see FLOW DIAGRAMS on the following pages		
Secondary pressure (relieving)	with relieving (standard) without relieving		
Fluid	compressed air		

CODING EXAMPLE

MC	2	02	-	R	T	0	2	-	VS	-	■	-	●
----	---	----	---	---	---	---	---	---	----	---	---	---	---

MC	SERIES
2	SIZE: 1 = G1/4 2 = G3/8 - G1/2
02	PORTS: 04 = G1/4 38 = G3/8 02 = G1/2
R	REGULATOR
T	WORKING PRESSURE 0 = 0.5 ÷ 10 bar (standard) 1 = 0 ÷ 4 bar 2 = 0 ÷ 2 bar (only G1/4) 7 = 0.5 ÷ 7 bar (only G1/4) T = calibrated* B = locked*
0	CONSTRUCTION: 0 = self-relieving (standard) 1 = non-relieving 5 = precise relieving
2	PRESSURE GAUGE: ** = without pressure gauge (standard) 1 = with pressure gauge 0-2.5, with working pressure 0 ÷ 2 bar 2 = with pressure gauge 0-6, with working pressure 0 ÷ 4 bar 3 = with pressure gauge 0-10, with working pressure 0.5 ÷ 7 bar 4 = with pressure gauge 0-12, with working pressure 0.5 ÷ 10 bar
VS	TIPO DI REGOLAZIONE: = without by-pass valve (standard) VS = with by-pass valve (solo G1/4)
<p>** NOTE: IF THE REGULATOR IS CALIBRATED OR LOCKED, AFTER THE PORTS ADD THE INLET PRESSURE "■" AND THE OUTLET PRESSURE "●"</p> <p>INLET PRESSURE: ■ = enter the SUPPLY pressure value</p> <p>OUTLET PRESSURE: ● = enter the OUTLET pressure value for the LOCKED regulator or the maximum value of the ADJUSTABLE pressure for the CALIBRATED regulator</p> <p>Example of a calibrated regulator with Inlet Pressure = 6.3 bar and Outlet Pressure = 4.5 bar Complete part number: MC104-MT03-6.3-4.5</p> <p>** the pressure gauges are supplied disassembly for size 1 pressure gauge mod. M043-P. for size 2 pressure gauge mod. M053-P..</p>	

Pressure regulators Series MC

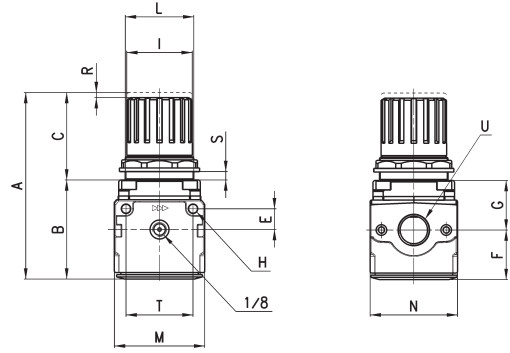

DIMENSIONS																
Mod.	A	B	C	E	F	G	H	I	L	M	N	R	S	T	U	
MC104-R00	94	56	38	11	28,5	27,5	4,5	28	30X1,5	45	45	3	0÷6	35	G1/4	
MC238-R00	127	67	60	14	34	35	5,5	45	47X1,5	62	60	3,5	0÷9	46	G3/8	
MC202-R00	127	67	60	14	34	35	5,5	45	47X1,5	62	60	3,5	0÷9	46	G1/2	

Pneumatic symbols

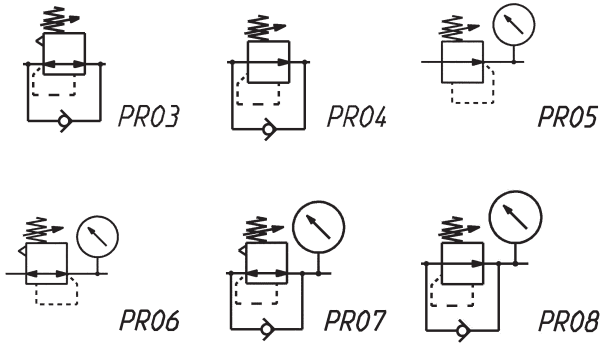

- PR03 = Regulator with relieving and by-pass valve
- PR04 = Regulator without relieving and with by-pass valve
- PR05 = Regulator without relieving and with pressure gauge
- PR06 = Regulator with relieving and pressure gauge
- PR07 = Regulator with relieving, by-pass valve and pressure gauge
- PR08 = Regulator without relieving with by-pass valve and pressure gauge

FLOW DIAGRAMS

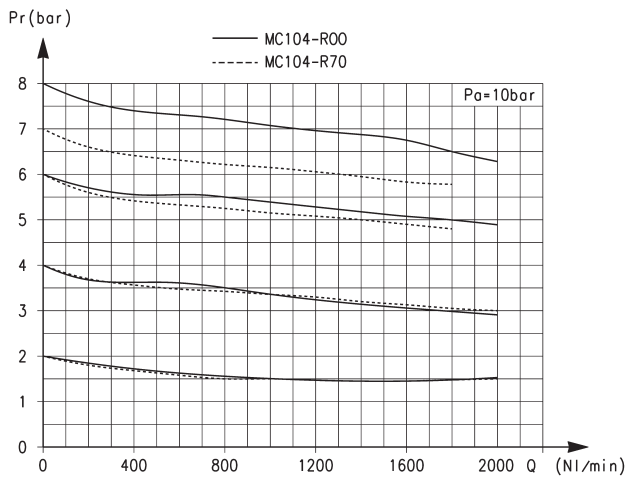

Flow diagrams for models: MC104-R00 and MC104-R70

Pa = Inlet pressure (bar)
Pr = Regulated pressure (bar)
Q = Flow (NI/min)

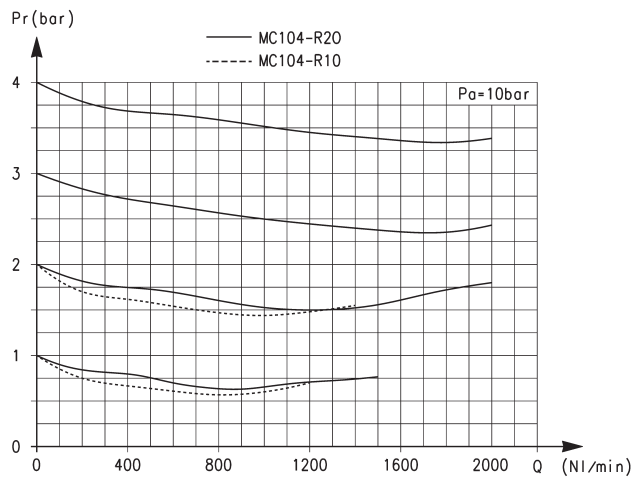

Flow diagrams for models: MC104-R10 and MC104-R20

Pa = Inlet pressure (bar)
Pr = Regulated pressure (bar)
Q = Flow (NI/min)

FLOW DIAGRAMS

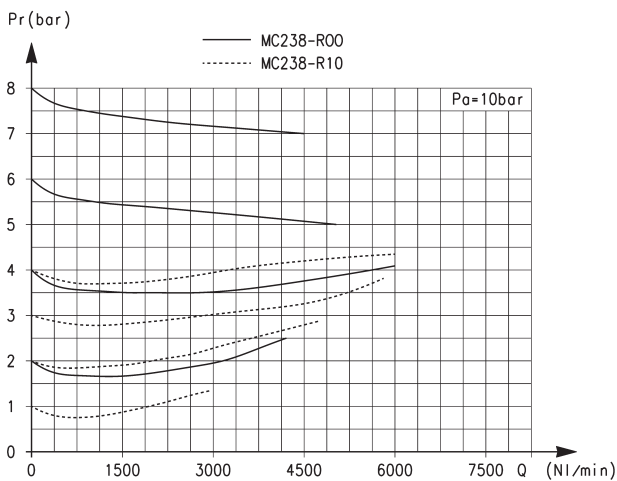

Flow diagrams for models: MC238-R00 and MC238-R10

Pa = Inlet pressure (bar)
Pr = Regulated pressure (bar)
Q = Flow (NI/min)

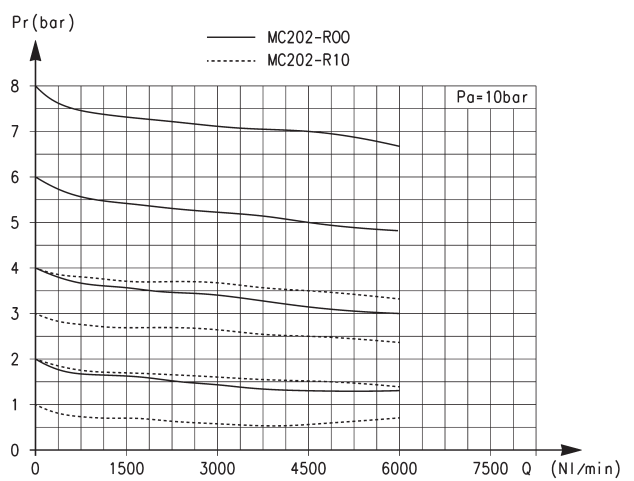

Flow diagrams for models: MC202-R00 and MC202-R10

Pa = Inlet pressure (bar)
Pr = Regulated pressure (bar)
Q = Flow (NI/min)