

CATALOGUE



FLUID CONTROL
SOLUTIONS FOR INDUSTRIAL
AND LIFE SCIENCE APPLICATIONS





WELCOME TO THE WORLD OF CAMOZZI

For more than 50 years Camozzi Automation is leader in the design and production of motion and fluid control components, systems and technologies for Industrial Automation, Transportation and Life Science industries.

Introduction

Camozzi solutions for fluid control	1
-------------------------------------	---

1 Solenoid valves and valves for fluids

Series K8-K8X directly operated solenoid valves - 8mm	9
Series K8B pilot operated solenoid valves - 8mm	14
Series K8DV directly operated solenoid valves with fluid separation membrane - 8mm	20
Series K directly operated solenoid valves - 10mm	25
Series KL - KLE directly operated solenoid valves	32
Series KN and KN High flow directly operated solenoid valves - 10mm	40
Series W directly operated solenoid valves - 15mm	44
Series P directly operated solenoid valves - 15mm	50
Series PL directly operated solenoid valves - 15mm	58
Series PN directly operated solenoid valves - 15mm	67
Series PD directly operated solenoid valves - 15mm	73
Series PDV directly operated solenoid valves with fluid separation membrane	80
Series A directly operated solenoid valves - 22mm	87
Series 6 directly operated solenoid valves - 30mm	96
Series CFB solenoid valves	100
Series CFB stainless steel solenoid valves	108
Series 8 pneumatic operated cartridge valves	111
Series 8 pneumatically and electropneumatically operated valves	114
Series TC shut-off micro-valves	119
Series ASX angle seat valves	123
Series ASP angle seat valves	136
Solenoids	144
Series VNR unidirectional valves	151
Series VSO, VSC quick exhaust valves	154
Adjustable overpressure exhaust valve Mod. VMR 1/8-B10	157
Series VBO - VBU blocking valves	159
Flow control valves	164

Coming soon

2 Proportional technology

Series AP directly operated proportional valves - 16mm and 22mm	168
Series CP directly operated proportional solenoid valves - 16mm and 20mm	179
Series 130 electronic control device for proportional valves	188
Series LR digital proportional servo valves	191
Open Frame Controller Modular proportional regulator	200
Series K8P electronic proportional micro regulator	207
Series MX-PRO electronic proportional regulator	213
Series PRE proportional pressure regulator with CoilVision technology	230

3 Treatment and fluid control

Series N filter-regulators	246
Series TC pressure microregulators	249
Series PR precision regulators with manual override	254
Series CLR micro pressure regulators	261
Series M pressure microregulators	265
Series T pressure microregulators	267
Series PG digital pressure gauges	269

4 Fittings, connectors, tubing and accessories

OX1 fittings and accessories for applications of medical gases	273
----------------------------------------------------------------	-----

Appendix

Valve islands	a.01
Vacuum and pressure switches	a.02
Series MD modular FRL units	a.03
Fittings	a.04
Chemical compatibility of materials	a.05
Conversion tables	a.07
Flow measuring	a.09
Fluid viscosity	a.09
Solenoid valves dimensioning	a.10
Specifications of Camozzi Clean room	a.10
ATEX Directive 2014/34/EU	a.11
ATEX certified Camozzi products	a.12
IP protection class	a.12
Fluid Control range of products	a.13
BQF (Business Qualification Form)	a.17

CAMOZZI, ABOUT US



Camozzi Automation is one of the world's leading suppliers of advanced **pneumatic components** and systems for industrial automation with a network of subsidiaries and distributors serving more than 70 countries spanning the world. Our offering includes motion and fluid (both liquids and gases) control components, systems and technologies for any application sector.

Our mission is to accompany you in the development of innovative, efficient and **high added value** solutions that can positively impact the future of the environment and people. We do this through our components, designed to allow you to better face future technological challenges. In a highly competitive context like today's,

it is of essential importance to be able to distinguish yourself from others by also offering **processes, skills, technologies and services** to support the product. Our goal is to work closely with our customers, establishing a **long-term relationship** to accompany them towards the future.

SOLUTIONS FOR INDUSTRIAL AND LIFE SCIENCE APPLICATIONS

The science of **fluid control** encompasses various technologies, application sectors and industries. Regardless of the sector involved, it is essential to understand the physical properties of the liquid or gas in order to correctly control its **flow and pressure**.

Our engineers dealing with fluid control applications are able to **offer highly engineered**

and specialised components and solutions for the main industrial sectors as well as for more delicate applications in the medical and analytical fields.

Our **range of Camozzi products** includes both single components, such as valves and solenoid valves, proportional valves, servo-valves, pressure and flow regulators, fittings and components for air treatment, as well as complete **customised systems**.

FLUID CONTROL

Industrial Automation



Life Science

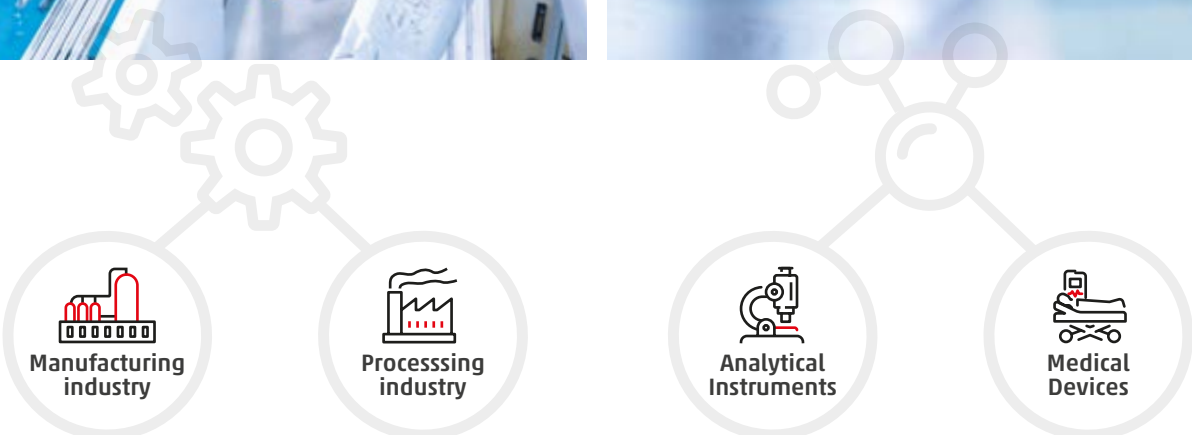

Manufacturing industry

Processing industry

Analytical Instruments

Medical Devices



INDUSTRIAL AUTOMATION

In industrial systems and machines, solutions for **motion and fluid control** often coexist. Industrial manufacturing sectors such as food & beverage, textile and printing or process industries such as the oil & gas, energy or chemical industry require components that **reliably and safely** control gases and liquids of different kinds, from air or water, to substances that can be flammable, oxidizing or harmful to human health.

Our solutions, in particular solenoid valves, fittings, flow and pressure regulators, **meet the main needs of all industrial sectors** in terms of reliability, flow rate and compatibility with liquids and gases.



Applications:

- Cleaning machines and equipment
- Sterilisation
- Textile
- Packaging and printing
- Injection and plastics
- Food & Beverage
- Renewable energy and machinery
- Machine tools
- Waste treatment and paint disposal
- Air-conditioning, heating and cooling
- Humidification
- Water treatment and control
- Peripheral processes for food and pharmaceutical industries
- Sanitary appliances
- Biogas and fuel cells
- Chemical and petrochemical equipment
- Water purification and osmosis
- Filling and PET processes





LIFE SCIENCE

The **life science sector** includes technologies and devices useful to diagnose, monitor, evaluate and cure patients with a wide variety of **symptoms and diseases**.

Life Science application areas are **extremely broad** and with very different peculiarities according to the application. In medical devices it is essential to guarantee **quality, reliability** and **safety** for the person, while in analytical devices it is essential to guarantee **high performance**, such as: precision and accuracy of controlled flows.

Our components **meet the main industry requirements** in terms of compatibility with fluids, energy efficiency, miniaturisation and standards for **total safety to guarantee people's health**.

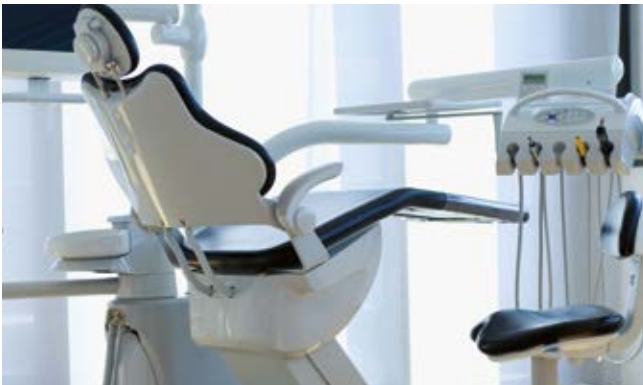

Medical devices:

- Dental equipment
- Anaesthesia
- Ventilators
- Incubators
- Dialysis equipment
- Hospital sterilizers
- Vacuumtherapy
- Pressotherapy
- Ophthalmology
- Oxygentherapy
- Oxygen concentrators
- Pressure measurement
- Surgery equipment
- Dosing and dispensing
- Drug infusion equipment
- Emergency ventilators
- Oxy & medical gas control

Analytical instruments:

- Mass Spectrometry
- Gas Chromatography and Liquid Chromatography
- Biomedical Analysis
- Environmental Analysis
- Molecular Analysis
- Genomics



STANDARD COMPONENTS

The solutions for the control of fluids (both liquids and gases) are characterised by a **modern and functional design** that allows to guarantee **high and constant performance** in any application field.

From packaging machinery to machine tools, from food & beverage machinery to those for waste treatment and paint disposal up to medical and analytical devices of the Life Science sector.

The large range of products embraces components to control pressure, flow and position and covers the **main application needs**.

These might be compactness and energy efficiency, as well as quick response times up to high flows and pressures.

- Valves and solenoid valves
- Proportional valves (flow and pressure)
- Air treatment and regulators
- Fittings



CUSTOMISED SOLUTIONS

Camozzi Automation proposes a broad range of **customised solutions** for the control of fluids (both liquids and gases) with the aim to help its partners to **improve the time to market** as well as the efficiency and reliability of their machines.

The components and special solutions may include the **engineering** of new products or the design of **customised manifolds** in which all necessary components are assembled in a

single block to create the desired fluid solution. This enables to reduce overall dimensions, dead volumes, losses and assembly and test times.

The experience gained over the years allows us to accompany our partners **from the idea to the implementation of the solution**, respecting constraints, standards, technical requirements and project times.



CAMOZZI: TOTAL QUALITY OF PRODUCTS AND PROCESSES

In order to guarantee the **best quality** in all production phases, Camozzi Automation has created controlled atmosphere environments and an **ISO 7 cleanroom** for the assembly of products and solutions that require extreme cleanliness (elimination of all organic and/or inorganic contaminants).

Ultrasonic cleaning and inspection equipment that makes use of UV blacklight enables us to **supply components** that can be used with **aggressive liquids** and **oxidizing gases** like oxygen.

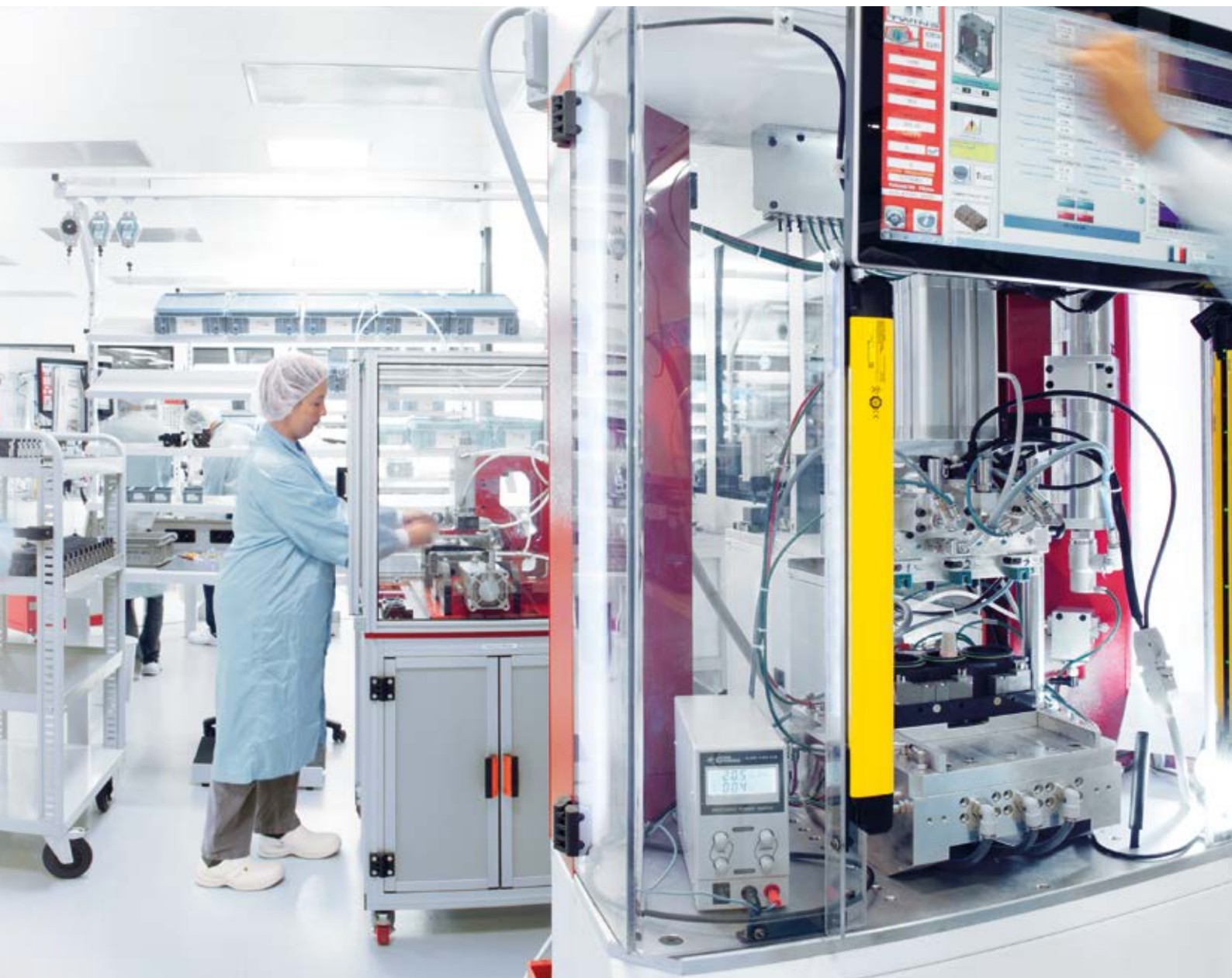

THE CAMOZZI CLEAN ROOM

In Camozzi all materials chosen for oxygen-enriched environments are carefully selected. Gaskets and non-metallic materials used for oxygen applications are designed to be compatible with oxygen.

No organic sealants, adhesives or lubricants are used in the manufacturing process.

An accurate level of cleanliness is guaranteed by qualified personnel and by rigorous cleaning procedures. Both organic and inorganic contaminants such as particulate matter and Hydrocarbon oils are removed by careful ultrasonic cleaning.

The process is periodically monitored through ASTM G93.



Valves, fittings, pressure regulators, manifolds and sub-bases can be supplied with two levels of cleanliness:

OX 1

Non-volatile residue equal to or less than 550 mg/m²
 Level OX1: ultrasonic cleaning of components, inspection with UV black light, lubrication (only if necessary for the product's operation) with a specific grease suitable to be used with oxygen. Assembly, testing and packaging outside the clean room.

OX 2

Non-volatile residue equal to or less than 33 mg/m²
 Level OX2: ultrasonic cleaning of components, inspection with UV black light, lubrication (only if necessary for the product's operation) with a specific grease suitable to be used with oxygen. Assembly, testing and packaging inside a clean room with ISO 7 classification according to ISO 14644-1.

Class	Maximum number of particles/m ³			FED STD 209E
	≥ 0.5 μm	≥ 1 μm	≥ 5 μm	
ISO 7	352,000	83,200	2,930	Class 10,000

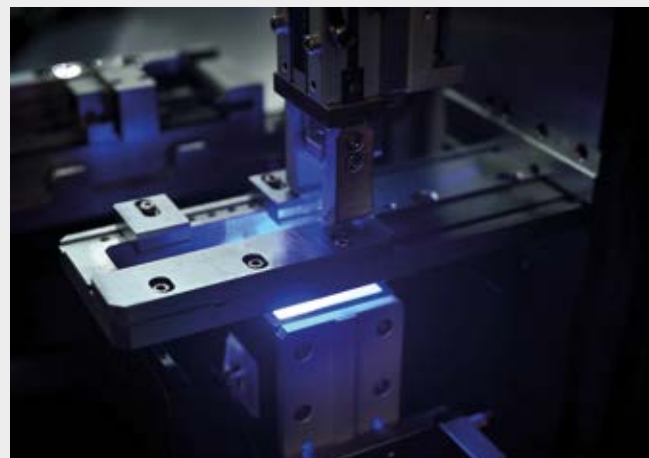

UV Black light provides evidence of eventual traces of hydrocarbons, grease or particulate.

Series K8 - K8X directly operated solenoid valves

2/2-way - Normally Closed (NC) and Normally Open (NO)
3/2-way - Normally Closed (NC) and Normally Open (NO)
3/2-way - Universal (UNI)

SERIES - K8-K8X SOLENOID VALVES

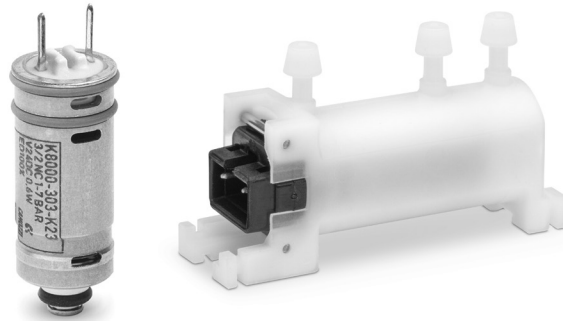

- » Compact design
- » High performances
- » Manifold mounting
- » Long life
- » Version for use with oxygen available

The universal (UNI) version enables to mix two different gaseous fluids or to select the path of the gaseous fluid in the pneumatic circuit.

Thanks to their particular design these valves can be used in applications where very compact solutions are required as well as high performances. Series K8 is used to control actuators or very small devices and it is suitable for portable equipments thanks to low power consumption, reduced weight and dimensions.

GENERAL DATA

TECHNICAL FEATURES

Function	2/2 NC - 3/2 NC - 2/2 NO - 3/2 NO - 3/2 UNI
Operation	direct acting poppet type
Pneumatic connections	cartridge seat in manifold / barb fittings for tube 4/2 - 4/2.5 - 5/3 mm
Orifice diameter	0.5 ... 0.7 mm
Flow efficient kv (l/min)	0.08 ... 0.15
Operating pressure	-1 ÷ 3 ... 7 bar
Operating temperature	0 ÷ 50 °C
Media	filtered compressed air, unlubricated, according to ISO 8573-1 class 3.4.3, inert gas
Response time (ISO 12238)	ON <10 ms - OFF <10 ms
Installation	in any position

MATERIALS IN CONTACT WITH THE MEDIUM

Body	brass - stainless steel - PBT
Seals	FKM
Internal parts	stainless steel - enamelled copper

ELECTRICAL FEATURES

Voltage	3 ... 24 V DC - other voltages on demand
Voltage tolerance	±10%
Power consumption	0.6 W
Duty cycle	ED 100%
Electrical connection	2 pins 0.5 x 0.5 pitch 4 mm - JST connector with 300 mm flying leads
Protection class	IP00

Special versions available on demand

CODING EXAMPLE

K8	0	00	-	3	0	3	-	K	2	3
-----------	----------	-----------	----------	----------	----------	----------	----------	----------	----------	----------

K8	SERIES
0	VALVE VERSION 0 = cartridge valve X = cartridge valve with PBT body
00	BODY DESIGN 00 = cartridge valve without body 1A = valve with PBT body and barb fittings for tube Ø 4/2 mm 1B = valve with PBT body and barb fittings for tube Ø 4/2.5 mm 1C = valve with PBT body and barb fittings for tube Ø 5/3 mm
3	NUMBER OF WAYS - FUNCTIONS 3 = 3/2-way - NC 4 = 3/2-way - NO 5 = 2/2-way - NC 6 = 2/2-way - NO 7 = 3/2-way - UNI
0	SEALS MATERIAL 0 = FKM
3	ORIFICE DIAMETER 3 = Ø 0.5 mm (max pressure 7 bar) 5 = Ø 0.7 mm 6 = Ø 0.5 mm (max pressure 4 bar)
K	MATERIALS K = brass orifice
2	ELECTRICAL CONNECTION 2 = pins - pitch 4 mm 3 = JST connector with 300 mm flying leads
3	VOLTAGE - POWER CONSUMPTION: 1 = 6 V DC - 0.6 W 2 = 12 V DC - 0.6 W 3 = 24 V DC - 0.6 W 5 = 5 V DC - 0.6 W 6 = 3 V DC - 0.6 W
	OPTIONS = standard OX1 = for use with oxygen (non volatile residual less than 550 mg/m ²)

SERIES - K8-K8X SOLENOID VALVES

AVAILABLE FUNCTIONS

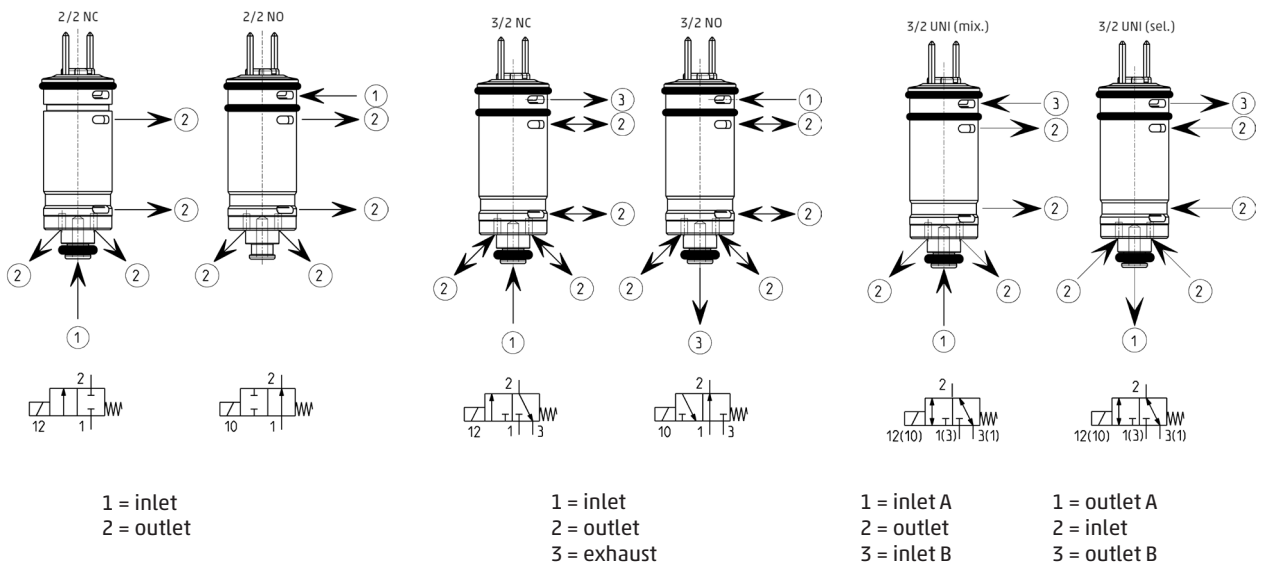

Series K8 solenoid valve - cartridge version



* add
- VOLTAGE
(see CODING EXAMPLE)

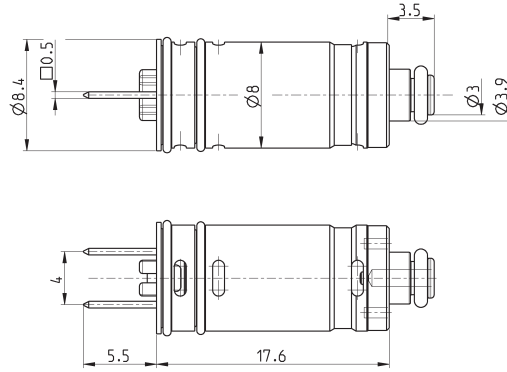
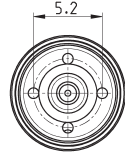

SERIES - K8-K8X SOLENOID VALVES

Mod.	Function	Orifice Ø (mm)	kv (l/min)	Min+max pressure (bar)
K8000-503-K2 ^{2*}	2/2 NC	0.5	0.08	1 ÷ 7
K8000-506-K2 ^{2*}	2/2 NC	0.5	0.08	-1 ÷ 4
K8000-505-K2 ^{2*}	2/2 NC	0.7	0.15	-1 ÷ 3
K8000-603-K2 ^{2*}	2/2 NO	0.6	0.10	1 ÷ 7
K8000-606-K2 ^{2*}	2/2 NO	0.6	0.10	-1 ÷ 4
K8000-303-K2 ^{2*}	3/2 NC	0.5	0.08	1 ÷ 7
K8000-306-K2 ^{2*}	3/2 NO	0.5	0.08	-1 ÷ 4
K8000-305-K2 ^{2*}	3/2 NC	0.7	0.15	-1 ÷ 3
K8000-403-K2 ^{2*}	3/2 NO	0.6	0.10	1 ÷ 7
K8000-406-K2 ^{2*}	3/2 NO	0.6	0.10	-1 ÷ 4
K8000-405-K2 ^{2*}	3/2 NO	0.6	0.10	1 ÷ 7
K8000-703-K2 ^{2*}	3/2 UNI	0.5	0.08	0 ÷ 3
K8000-705-K2 ^{2*}	3/2 UNI	0.7	0.15	-1 ÷ 2

Series K8 solenoid valve - valve seat dimensions for manifolds

LEGEND:
1 = Port 1
2 = Port 2
3 = Port 3
4 = Free from burrs
5 = Surface to be aligned with the upper surface of the valve reinforcement

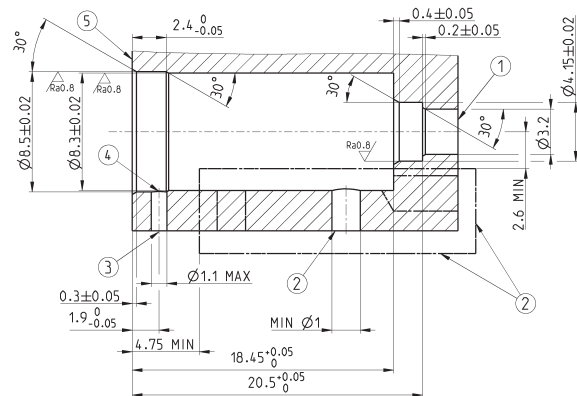

FUNCTION	2/2 NC	2/2 NO	3/2 NC	3/2 NO	3/2 UNI (mix.)	3/2 UNI (sel.)
PORT 1	inlet	-	inlet	exhaust	inlet A	outlet A
PORT 2	outlet	outlet	outlet	outlet	outlet	inlet
PORT 3	-	inlet	exhaust	inlet	inlet B	outlet B

New

Series K8X solenoid valve - PBT version body



* add
- BODY DESIGN
- VOLTAGE
(see CODING EXAMPLE)

Mod.	Function	Orifice Ø (mm)	kv (l/min)	Min+max pressure (bar)
K8X1*-503-K3*	2/2 NC	0.5	0.08	1 ÷ 7
K8X1*-506-K3*	2/2 NC	0.5	0.08	-1 ÷ 4
K8X1*-505-K3*	2/2 NC	0.7	0.15	-1 ÷ 3
K8X1*-603-K3*	2/2 NO	0.6	0.10	1 ÷ 7
K8X1*-606-K3*	2/2 NO	0.6	0.10	-1 ÷ 4
K8X1*-303-K3*	3/2 NC	0.5	0.08	1 ÷ 7
K8X1*-306-K3*	3/2 NC	0.5	0.08	-1 ÷ 4
K8X1*-305-K3*	3/2 NC	0.7	0.15	-1 ÷ 3
K8X1*-403-K3*	3/2 NO	0.6	0.10	1 ÷ 7
K8X1*-406-K3*	3/2 NO	0.6	0.10	-1 ÷ 4
K8X1*-405-K3*	3/2 NO	0.6	0.10	1 ÷ 7
K8X1*-703-K3*	3/2 UNI	0.5	0.08	0 ÷ 3
K8X1*-705-K3*	3/2 UNI	0.7	0.15	-1 ÷ 2

Series K8X solenoid valve - dimensions

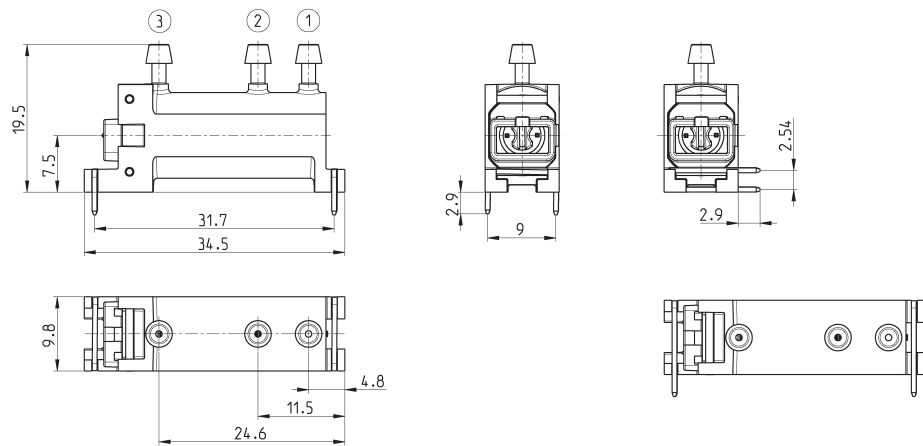

FUNCTION	2/2 NC	2/2 NO	3/2 NC	3/2 NO	3/2 UNI (mix.)	3/2 UNI (sel.)
PORT 1	inlet	-	inlet	exhaust	inlet A	outlet A
PORT 2	outlet	outlet	outlet	outlet	outlet	inlet
PORT 3	-	inlet	exhaust	inlet	inlet B	outlet B

Single body for Series K8 solenoid valve



Material: anodized aluminium
Connections: M5 threads

Valve restraint system to be used only with connector Mod. 120-J...

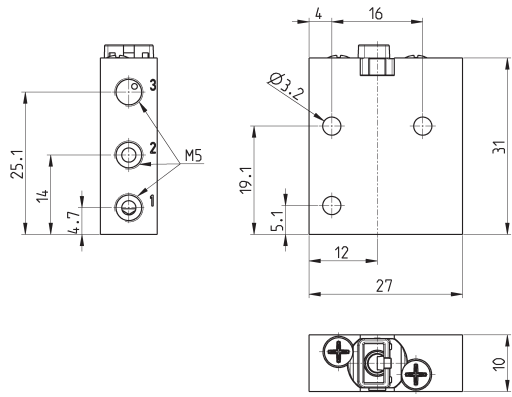

Mod.	
K8303/14C	

Connector with flying leads Mod. 120-J...



Flying leads section: 0.22 mm²
Flying lead external diameter: 1.1 mm
Material for the flying leads insulation: PVC

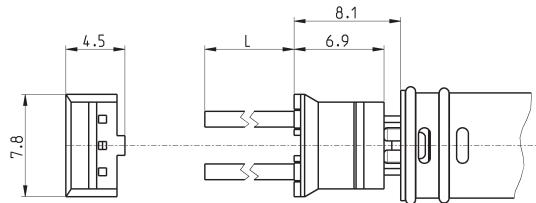

Mod.	description	colour	L = cable length (mm)	cable holding
120-J803	crimped cable connector J	white	300	crimping
120-J806	crimped cable connector J	white	600	crimping

Connector with flying leads Mod. 120-..



Cable section: 0.25 mm²
Cable external diameter: 1.2 mm
Material for the cable insulation: PVC

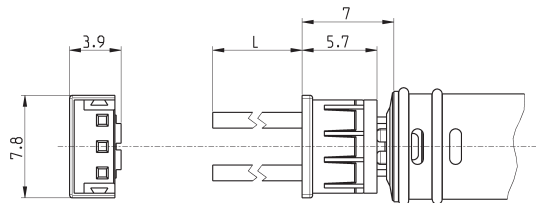

Mod.	description	colour	L = cable length (mm)	cable holding
120-803	crimped cable	white	300	crimping
120-806	crimped cable	white	600	crimping

Series K8B pilot operated solenoid valves

2/2-way - Normally Closed (NC) and Normally Open (NO)
3/2-way - Normally Closed (NC) and Normally Open (NO)



- » Compact design
- » High flow
- » Manifold mounting
- » Long life

Thanks to their low power consumption and light weight Series K8B solenoid valves are particularly suitable for use with portable equipment too.

Series K8B pilot operated solenoid valves represent the evolution of Series K8 which has been equipped with a flow amplifier. Their particular design makes these valves ideal for use in applications requiring very compact solutions and high flow.

GENERAL DATA

TECHNICAL FEATURES

Function	2/2 NC - 2/2 NO - 3/2 NC - 3/2 NO
Operation	pilot operated poppet type
Pneumatic connections	cartridge seat in manifold - M7 threads - on subbase
Orifice diameter	3.6 mm
Flow coefficient kv (l/min)	2.8
Operating pressure	1 ÷ 7 bar
Operating temperature	0 ÷ 50 °C
Media	filtered compressed air, unlubricated, according to ISO 8573-1 class 2.4.2, inert gas
Response time (ISO 12238)	ON <15 ms - OFF <15 ms
Installation	in any position

MATERIALS IN CONTACT WITH THE MEDIUM

Body	brass - stainless steel - PBT - aluminium
Seals	FKM
Internal parts	stainless steel - enamelled copper

ELECTRICAL FEATURES

Voltage	3 ... 24 V DC - other voltages on demand
Voltage tolerance	±10%
Power consumption	0.6 W
Duty cycle	ED 100%
Electrical connection	2 pins 0.5 x 0.5 pitch 4 mm - JST connector with 300 mm flying leads
Protection class	IP00

Special versions available on demand

CODING EXAMPLE

K8B	C5	4	00	-	D4	3	2	N	-	N	00	1A	C003
------------	-----------	----------	-----------	----------	-----------	----------	----------	----------	----------	----------	-----------	-----------	-------------

K8B	SERIES
C5	BODY DESIGN C0 = valve with aluminium body flanged connections C3 = valve with aluminium body threaded connections C5 = cartridge valve without body
4	NUMBER OF WAYS - FUNCTIONS 1 = 2/2-way - NC 2 = 2/2-way - NO 4 = 3/2-way - NC 5 = 3/2-way - NO
00	PNEUMATIC CONNECTIONS 00 = cartridge seat in manifold 03 = M7 thread 18 = 2/2-way K8B-type interface 19 = 3/2-way K8B-type interface
D4	ORIFICE DIAMETER D4 = Ø 3.6mm
3	SEALS MATERIALS 3 = FKM
2	MATERIALS 1 = stainless steel - brass - aluminium (valve with body version) 2 = stainless steel - brass (cartridge version)
N	MANUAL OVERRIDE N = not foreseen
N	FIXING N = not foreseen P = screws for plastics M = screws for metal
00	OPTION 00 = no option
1A	ELECTRICAL CONNECTION 2 = pins - pitch 4 mm 3 = JST connector with 300 mm flying leads
C003	VOLTAGE - POWER CONSUMPTION C001 = 6 V DC (0.6 W) C002 = 12 V DC (0.6 W) C003 = 24 V DC (0.6 W)
	OPTIONS: = standard OX1 = for use with oxygen (non volatile residual less than 550 mg/m ³)

AVAILABLE FUNCTIONS

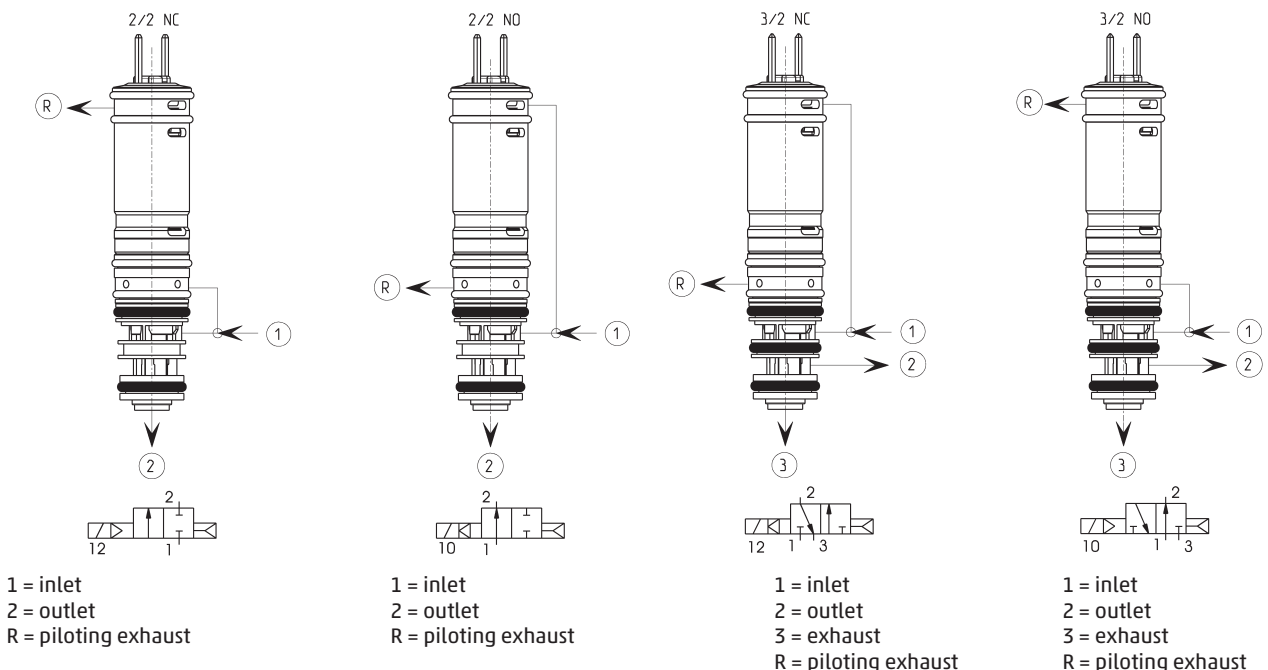

Solenoid valve Series K8B - cartridge version



* add
- VOLTAGE
(see CODING EXAMPLE)

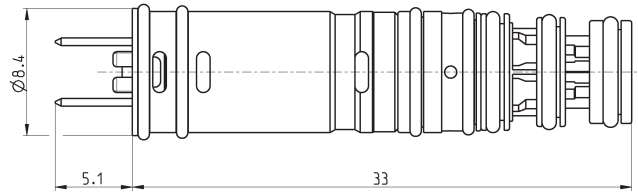

	Function	Orifice Ø (mm)	kv (l/min)	Min÷max pressure (bar)
K8BC5100-D432N-N001A*	2/2 NC	3.6	2.8	1÷7
K8BC5200-D432N-N001A*	2/2 NO	3.6	2.8	1÷7
K8BC5400-D432N-N001A*	3/2 NC	3.6	2.8	1÷7
K8BC5500-D432N-N001A*	3/2 NO	3.6	2.8	1÷7

Series K8B - seat dimensions cartridge version

To achieve the declared flow rate it is necessary to realize the ports with a section of 12.5 mm² (equal to a diameter of 4 mm)

* for the 2/2 version this operation has not to be performed

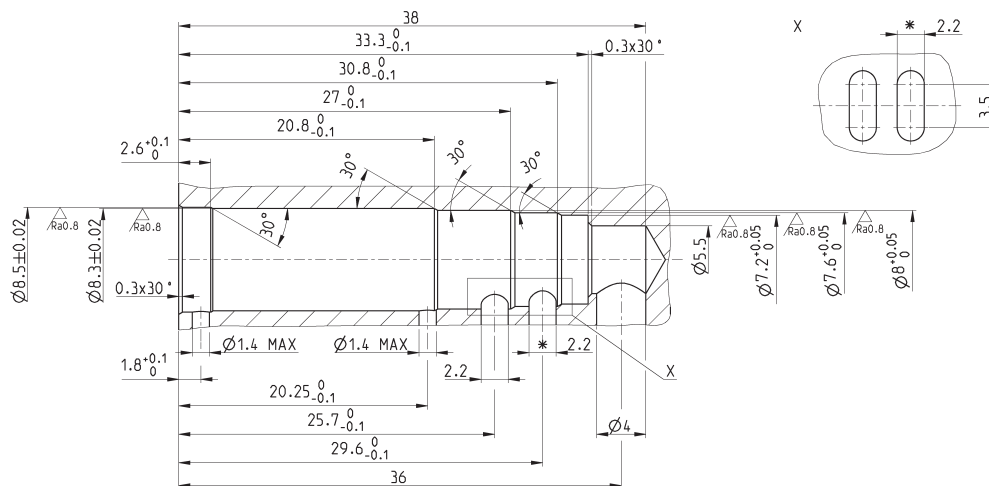

Series K8B solenoid valve - 2/2-way - threaded ports body version



Supplied with:
1x connector with flying leads
Mod. 120-J803 (300mm)

* add
- VOLTAGE
(see CODING EXAMPLE)

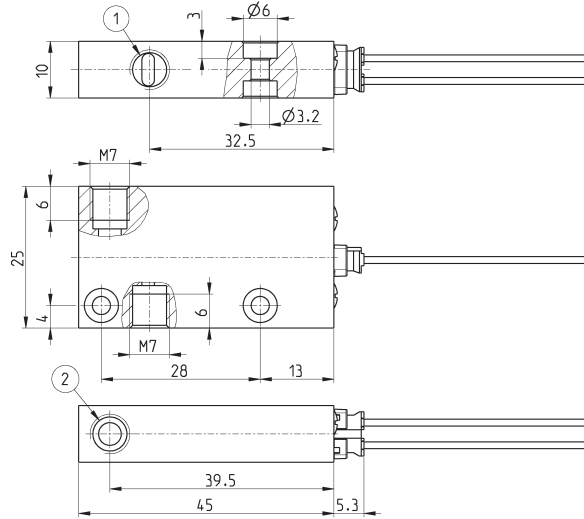
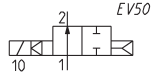
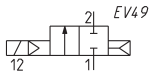

Mod.	Function	Orifice Ø (mm)	kv (l/min)	Min= max pressure (bar)
K8BC3103-D431N-N001B*	2/2 NC	3.6	2.8	1=7
K8BC3203-D431N-N001B*	2/2 NO	3.6	2.8	1=7

Series K8B solenoid valve - 3/2-way - threaded ports body version



Supplied with:
1x connector with flying leads
Mod. 120-J803 (300mm)

* add
- VOLTAGE
(see CODING EXAMPLE)

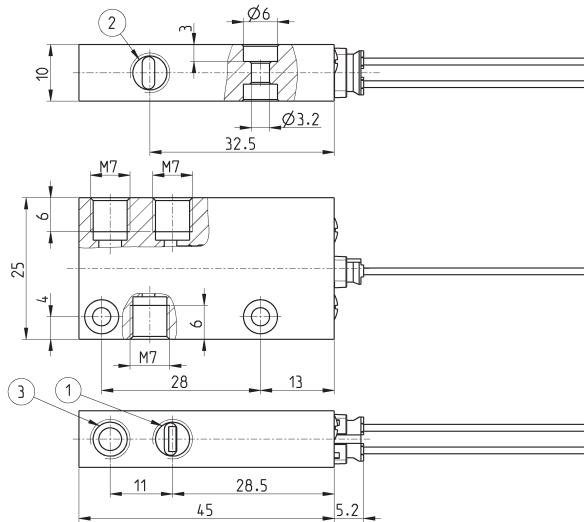
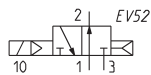
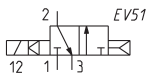

Mod.	Function	Orifice Ø (mm)	kv (l/min)	Min= max pressure (bar)
K8BC3403-D431N-N001B*	3/2 NC	3.6	2.8	1=7
K8BC3503-D431N-N001B*	3/2 NO	3.6	2.8	1=7

Series K8B solenoid valve - 2/2-way - flanged body version



Supplied with:
 1x connector with flying leads
 Mod. 120-J803 (300mm)
 2x interface seals
 2x M3x6 screws for mounting on metal
 or
 2x Ø3x6 screws for mounting on plastic

* add
 - FIXING
 - VOLTAGE
 (see CODING EXAMPLE)

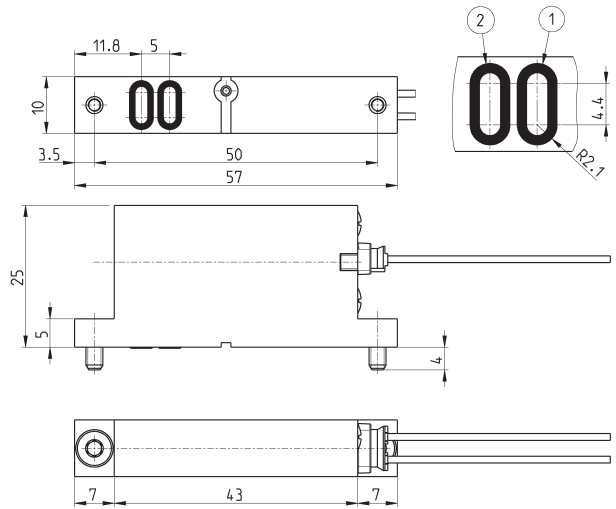
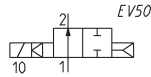
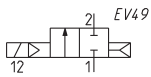

Mod.	Function	Orifice Ø (mm)	kv (l/min)	Min= max pressure (bar)
K8BC0118-D431N-*001B*	2/2 NC	3.6	2.8	1÷7
K8BC0218-D431N-*001B*	2/2 NO	3.6	2.8	1÷7

Series K8B solenoid valve - 3/2-way - flanged body version



Supplied with:
 1x connector with flying leads
 Mod. 120-J803 (300mm)
 3x interface seals
 2x M3x6 screws for mounting on metal
 or
 2x Ø3x6 screws for mounting on plastic

* add
 - FIXING
 - VOLTAGE
 (see CODING EXAMPLE)

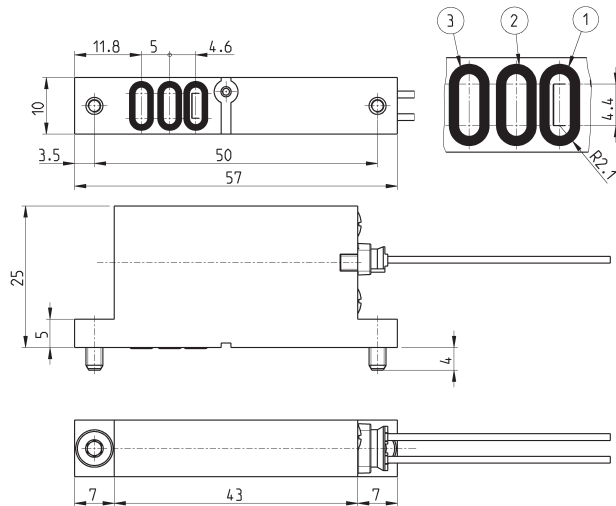
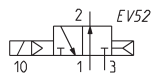
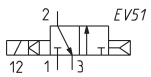

Mod.	Function	Orifice Ø (mm)	kv (l/min)	Min= max pressure (bar)
KBC0419-D431N-*001B*	3/2 NC	3.6	2.8	1÷7
KBC0519-D431N-*001B*	3/2 NO	3.6	2.8	1÷7

Connector with flying leads Mod. 120-J...



Flying leads section: 0.22 mm²
 Flying lead external diameter: 1.1 mm
 Material for the flying leads insulation: PVC

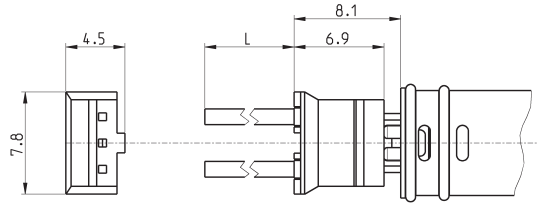

SERIES K8B SOLENOID VALVES

Mod.	description	colour	L = cable length (mm)	cable holding
120-J803	crimped cable connector J	white	300	crimping
120-J806	crimped cable connector J	white	600	crimping

Series K8DV diaphragm isolation valves directly operated

2/2-way - Normally Closed (NC)



- » Very compact design and reduced weight
- » High flow performances
- » Very low internal volume
- » Suitable to be applied in medical equipment and analytical instruments

To choose the most suitable model for a specific application, check the chemical compatibility of the medium to control with the available materials of body and seals.

The K8DV solenoid valve was born to meet all the demands to shut off aggressive or heat sensitive fluids. Thanks to a fluid separation membrane, the fluid is isolated from all internal metal parts of the solenoid valve and avoids heating, even if minimum, generated by the solenoid positioned above.

GENERAL DATA

TECHNICAL FEATURES

Function	2/2 NC
Operation	directly operated with fluid separation membrane
Pneumatic connections	cartridge seat in manifold - on subbase
Orifice diameter	0.7 mm
Flow efficient kv (l/min)	0.1
Operating pressure	0 ÷ 2.1 bar (FKM/EPDM) / 0 ÷ 1.5 bar (FFKM)
Operating temperature	5 ÷ 50 °C (FKM/EPDM) / 20 ÷ 50 °C (FFKM)
Media	inert or corrosive liquids and gases compatible with the materials in contact
Response time	ON ≤ 10 ms - OFF ≤ 15 ms
Installation	in any position

MATERIALS IN CONTACT WITH THE MEDIUM

Body	PEEK
Seals	FKM - EPDM - FFKM

ELECTRICAL FEATURES

Voltage	3 ... 24 V DC - other voltages on demand
Voltage tolerance	±10%
Power consumption	0.6 W
Duty cycle	ED 100%
Electrical connection	2 pins 0.5 x 0.5 pitch 4 mm
Protection class	IP00

CODING EXAMPLE

K8DV	C	00	-	5	0	5	-	G	2	3
-------------	----------	-----------	----------	----------	----------	----------	----------	----------	----------	----------

K8DV	SERIES
C	TYPE OF BODY C = cartridge version 0 = flanged version
00	NUMBER OF POSITIONS 00 = valve without housing
5	NUMBER OF WAYS - FUNCTIONS 5 = 2/2-way - NC
0	SEAL MATERIAL 0 = FKM 4 = EPDM 5 = FFKM
5	ORIFICE DIAMETER 5 = Ø 0.7 mm
G	BODY MATERIAL G = PEEK
2	ELECTRICAL CONNECTION 2 = pins - pitch 4 mm
3	VOLTAGE - POWER CONSUMPTION 1 = 6V DC - 0.6 W 2 = 12V DC - 0.6 W 3 = 24V DC - 0.6 W 4 = 3V DC - 0.6 W 5 = 5V DC - 0.6 W
	OPTIONS: = standard OX1 = for use with oxygen (non volatile residual less than 550 mg/m ²)

SERIES K8DV SOLENOID VALVES

Series K8DV solenoid valve - cartridge version

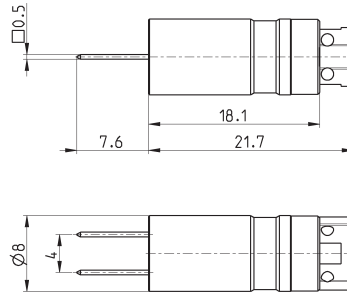
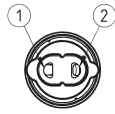

DRAWING LEGEND:

1 = inlet
2 = outlet

* add
- VOLTAGE
(see CODING EXAMPLE)

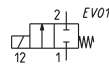

Mod.	Orifice Ø (mm)	kv (l/min)	Min+max pressure (bar)	Body material	Seal material
K8DVC00-505-G2*	0.7	0.1	0 ÷ 2.1	PEEK	FKM
K8DVC00-545-G2*	0.7	0.1	0 ÷ 2.1	PEEK	EPDM
K8DVC00-555-G2*	0.7	0.1	0 ÷ 1.5	PEEK	FFKM

Series K8DV - seat dimensions cartridge version

DRAWING LEGEND:

1 = inlet
2 = outlet

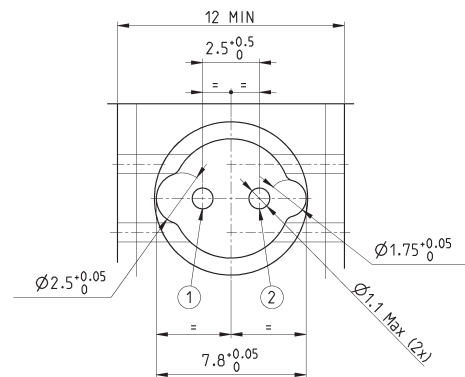
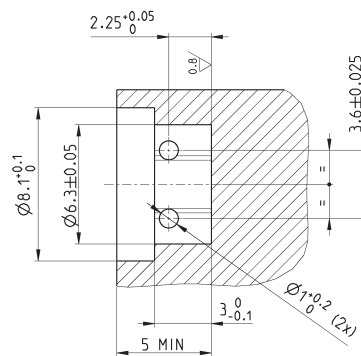

Serie K8DV solenoid valve - flanged version

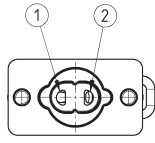

DRAWING LEGEND:
1 = inlet
2 = outlet

* add
- VOLTAGE
(see CODING EXAMPLE)

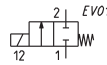
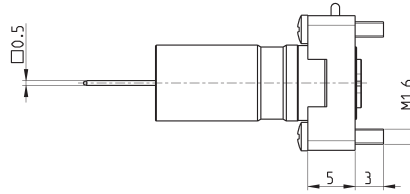
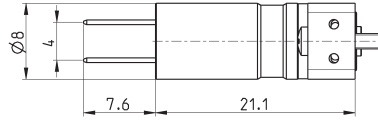

Mod.	Orifice Ø (mm)	kv (l/min)	Min+max pressure (bar)	Body material	Seal material
K8DV000-505-G2*	0.7	0.1	0 ÷ 2.1	PEEK	FKM
K8DV000-545-G2*	0.7	0.1	0 ÷ 2.1	PEEK	EPDM
K8DV000-555-G2*	0.7	0.1	0 ÷ 1.5	PEEK	FFKM

Series K8DV - seat dimensions flanged version

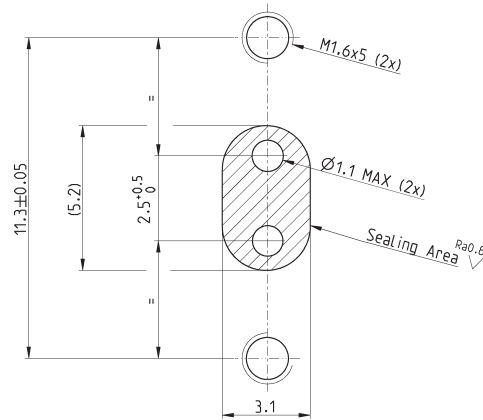

Single sub base for flanged version



Material: PEEK
Pneumatic connections: M5 or 1/4-28 UNF threads

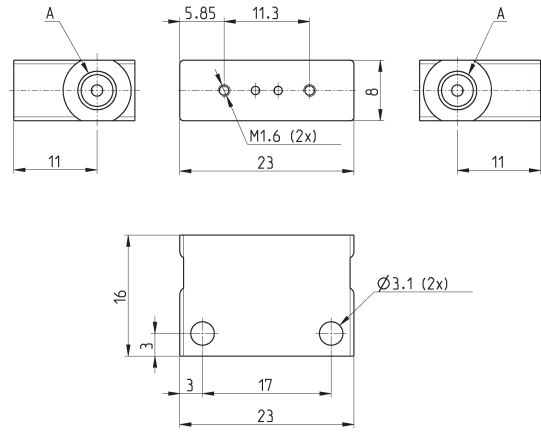

Mod.	Thread A
K8DV0001-1/4	1/4 - 28 UNF
K8DV0001-M5	M5

Connector with flying leads Mod. 120-J...



Flying leads section: 0.25 mm²
Flying lead external diameter: 1.2 mm
Material for the flying leads insulation: PVC

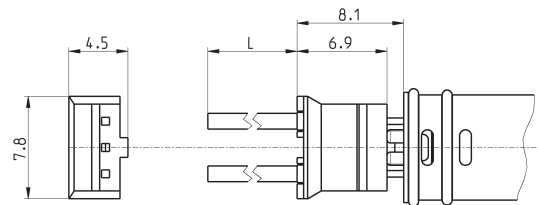

Mod.	description	colour	L = cable length (mm)	cable holding
120-J803	crimped cable connector J	white	300	crimping
120-J806	crimped cable connector J	white	600	crimping

Connector with flying leads Mod. 120-..



Cable section: 0.25 mm²
Cable external diameter: 1.2 mm
Material for the cable insulation: PVC

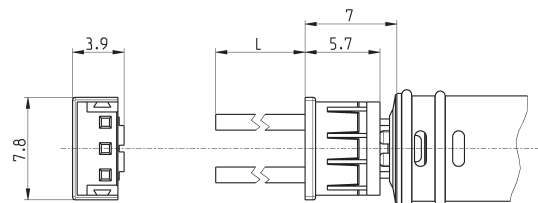

Mod.	description	colour	L = cable length (mm)	cable holding
120-803	crimped cable	white	300	crimping
120-806	crimped cable	white	600	crimping

Series K directly operated solenoid valves

2/2-way - Normally Closed (NC)

3/2-way - Normally Closed (NC) and Normally Open (NO)

SERIES K SOLENOID VALVES

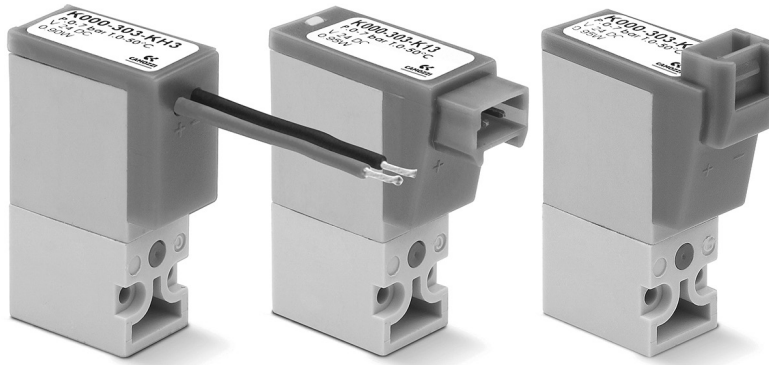

- » Low power consumption
- » Compact design
- » Version for use with oxygen available

The Series K directly operated solenoid valves can be mounted on single sub-bases or manifolds.
Thanks to the same mounting pad 2/2-way and 3/2-way versions can be installed on the same manifold.
The manual override is available only for the 3/2-way versions.

GENERAL DATA

TECHNICAL FEATURES

Function	2/2 NC - 3/2 NC - 3/2 NO
Operation	direct acting poppet type
Pneumatic connections	on subbase
Orifice diameter	0.6 ... 1 mm
Flow coefficient kv (l/min)	0.12 ... 0.30
Operating pressure	0 ÷ 3 ... 7 bar
Operating temperature	0 ÷ 50 °C
Media	filtered compressed air, unlubricated, according to ISO 8573-1 class 3.4.3, inert gas
Response time	ON <10 ms - OFF <10 ms
Manual override	monostable - only for 3/2 versions
Installation	in any position

MATERIALS IN CONTACT WITH THE MEDIUM

Body	PBT
Seals	NBR - FKM
Internal parts	stainless steel

ELECTRICAL FEATURES

Voltage	6 ... 24 VDC - other voltages on demand
Voltage tolerance	±10%
Power consumption	1 W
Duty cycle	ED 100%
Electrical connection	connector mod. 121-8... - 300 mm flying leads
Protection class	IP50

Special versions available on demand

CODING EXAMPLE

K	0	00	-	3	0	3	-	K	2	3	
----------	----------	-----------	----------	----------	----------	----------	----------	----------	----------	----------	--

K	SERIES										
0	BODY DESIGN 0 = single sub-base (only M5) or interface 1 = manifold										
00	NUMBER OF POSITIONS 00 = interface 01 = single base (only M5) 02 - 99 = manifold number of positions										
3	NUMBER OF WAYS - FUNCTIONS 0 = manifold or single base 1 = 2/2-way - NC 1 = 2/2-way - NC electric part revolved by 180° 3 = 3/2-way - NC 5 = 3/2-way - NC electric part revolved by 180° 4 = 3/2-way - NO 6 = 3/2-way - NO electric part revolved by 180°										
0	PORTS: 0 = on subbase or manifold 2 = M5 side outlets										
3	ORIFICE DIAMETER 2 = Ø 0.6 mm 3 = Ø 0.65 mm 5 = Ø 1.0 mm										
K	MATERIALS F = PBT body - FKM poppet seal K = PBT body - HNBR poppet seal (only for 3/2-way versions)										
2	ELECTRICAL CONNECTION 1 = 90° connection with protection and led 2 = 90° connection with protection 3 = 90° connection B = in-line connection with protection and led C = in-line connection with protection D = in-line connection F = 300 mm flying leads with protection and led G = 300 mm flying leads with protection H = 300 mm flying leads										
3	VOLTAGE - POWER CONSUMPTION 1 = 6V DC - 1W 2 = 12V DC - 1W 3 = 24V DC - 1W										
	FIXING = fixing screws for plastic M = fixing screws for metal										
	OPTIONS = standard OX1 = for use with oxygen (non volatile residual less than 550 mg/m ²) OX2 = for use with oxygen (non volatile residual less than 33 mg/m ²)										

Series K solenoid valve - 2/2-way NC - 90° connector



Supplied with:
1x interface seal
2x Ø1.6x16 screws for mounting on plastic
or
2x M1.6x16 screws for mounting on metal

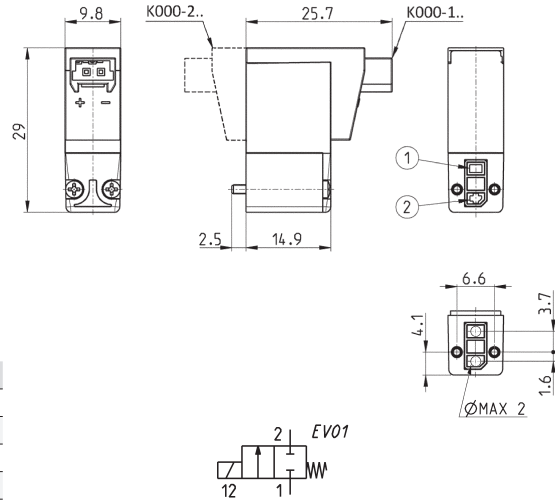

Mod.	Function	Orifice Ø (mm)	kv (l/min)	Min+max pressure (bar)
K000-102-F1	2/2 NC	0.6	0.15	0 ÷ 6
K000-102-F2	2/2 NC	0.6	0.15	0 ÷ 6
K000-102-F3	2/2 NC	0.6	0.15	0 ÷ 6
K000-105-F1	2/2 NC	1	0.30	0 ÷ 3
K000-105-F2	2/2 NC	1	0.30	0 ÷ 3
K000-105-F3	2/2 NC	1	0.30	0 ÷ 3

* add
- VOLTAGE
(see CODING EXAMPLE)

Series K solenoid valve - 2/2-way NC - in-line connector



Supplied with:
1x interface seal
2x Ø1.6x16 screws for mounting on plastic
or
2x M1.6x16 screws for mounting on metal)

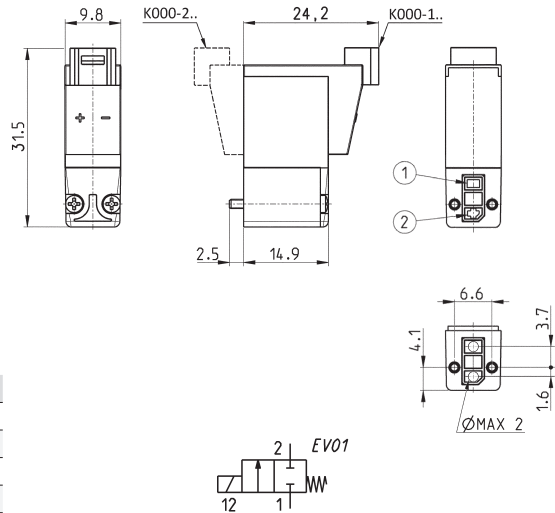

Mod.	Function	Orifice Ø (mm)	kv (l/min)	Min+max pressure (bar)
K000-102-FB	2/2 NC	0.6	0.15	0 ÷ 6
K000-102-FC	2/2 NC	0.6	0.15	0 ÷ 6
K000-102-FD	2/2 NC	0.6	0.15	0 ÷ 6
K000-105-FB	2/2 NC	1	0.30	0 ÷ 3
K000-105-FC	2/2 NC	1	0.30	0 ÷ 3
K000-105-FD	2/2 NC	1	0.30	0 ÷ 3

* add
- VOLTAGE
(see CODING EXAMPLE)

Series K solenoid valve - 2/2-way NC - 300 mm flying leads

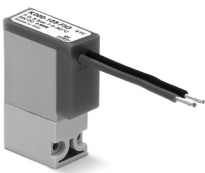

Supplied with:
1x interface seal
2x Ø1.6x16 screws for mounting on plastic
or
2x M1.6x16 screws for mounting on metal

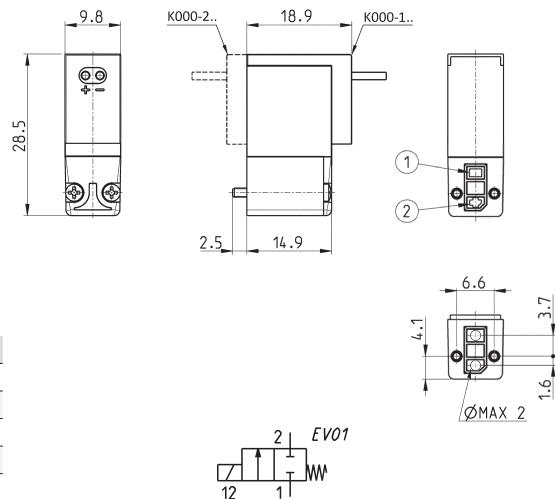

Mod.	Function	Orifice Ø (mm)	kv (l/min)	Min+max pressure (bar)
K000-102-FF	2/2 NC	0.6	0.15	0 ÷ 6
K000-102-FG	2/2 NC	0.6	0.15	0 ÷ 6
K000-102-FH	2/2 NC	0.6	0.15	0 ÷ 6
K000-105-FF	2/2 NC	1	0.30	0 ÷ 3
K000-105-FG	2/2 NC	1	0.30	0 ÷ 3
K000-105-FH	2/2 NC	1	0.30	0 ÷ 3
K000-102-FH3M-0X1	2/2 NC	0.6	0.15	0 ÷ 6

* add
- VOLTAGE
(see CODING EXAMPLE)

Seris K solenoid valve - 3/2-way NC - 90° connector



Supplied with:
 1x interface seal
 2x Ø1.6x16 screws for mounting on plastic
 or
 2x M1.6x16 screws for mounting on metal

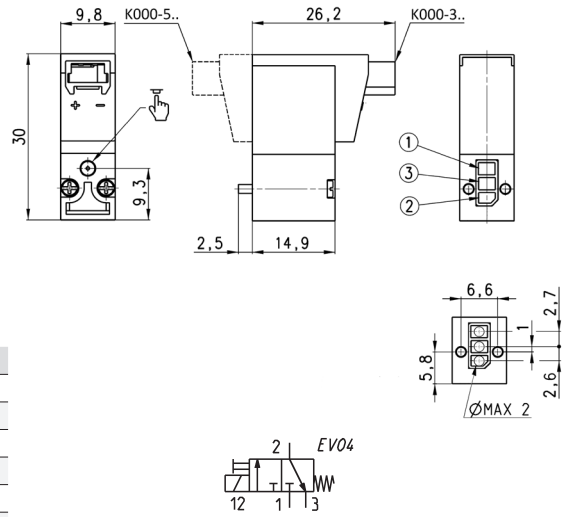

Mod.	Function	Orifice Ø (mm)	kv (l/min)	Min+max pressure (bar)
K000-303-K1	3/2 NC	0.6	0.12	0 ÷ 7
K000-303-F1	3/2 NC	0.6	0.12	0 ÷ 7
K000-303-K2	3/2 NC	0.6	0.12	0 ÷ 7
K000-303-F2	3/2 NC	0.6	0.12	0 ÷ 7
K000-303-K3	3/2 NC	0.6	0.12	0 ÷ 7
K000-303-F3	3/2 NC	0.6	0.12	0 ÷ 7
K000-303-K13M	3/2 NC	0.6	0.12	0 ÷ 7

* add
 - VOLTAGE
 (see CODING EXAMPLE)

Series K solenoid valve - 3/2-way NC - in-line connector



Supplied with:
 1x interface seal
 2x Ø1.6x16 screws for mounting on plastic
 or
 2x M1.6x16 screws for mounting on metal

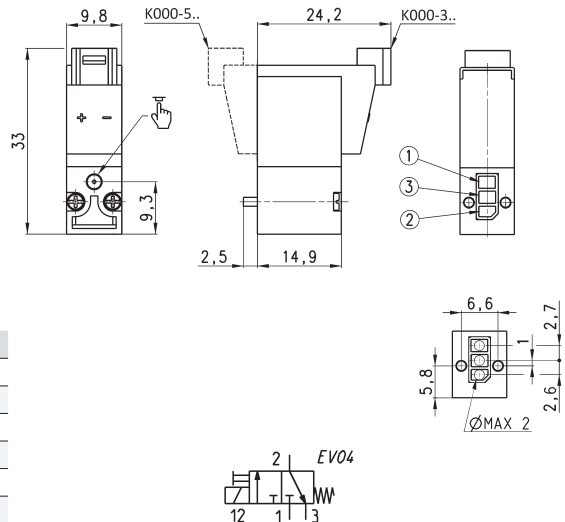

Mod.	Function	Orifice Ø (mm)	kv (l/min)	Min+max pressure (bar)
K000-303-KB	3/2 NC	0.6	0.12	0 ÷ 7
K000-303-FB	3/2 NC	0.6	0.12	0 ÷ 7
K000-303-KC	3/2 NC	0.6	0.12	0 ÷ 7
K000-303-FC	3/2 NC	0.6	0.12	0 ÷ 7
K000-303-KD	3/2 NC	0.6	0.12	0 ÷ 7
K000-303-FD	3/2 NC	0.6	0.12	0 ÷ 7
K000-303-KF3	3/2 NC	0.6	0.12	0 ÷ 7
K000-303-KH3	3/2 NC	0.6	0.12	0 ÷ 7

* add
 - VOLTAGE
 (see CODING EXAMPLE)

Series K solenoid valve - 3/2-way NC - 300 mm flying leads



Supplied with:
 1x interface seal
 2x Ø1.6x16 screws for mounting on plastic
 or
 2x M1.6x16 screws for mounting on metal

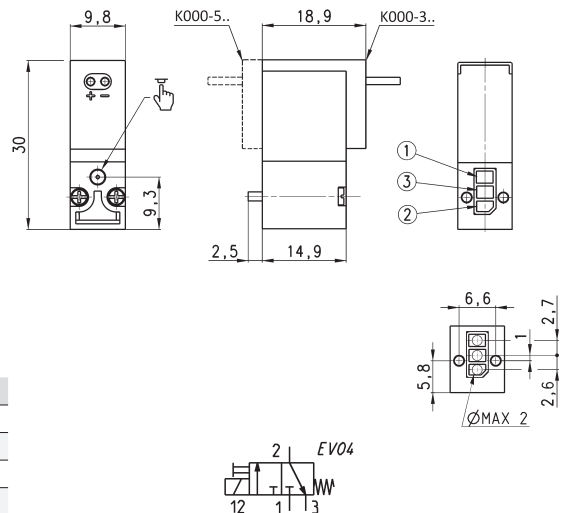

Mod.	Function	Orifice Ø (mm)	kv (l/min)	Min+max pressure (bar)
K000-303-KF	3/2 NC	0.6	0.12	0 ÷ 7
K000-303-FF	3/2 NC	0.6	0.12	0 ÷ 7
K000-303-KG	3/2 NC	0.6	0.12	0 ÷ 7
K000-303-FG	3/2 NC	0.6	0.12	0 ÷ 7
K000-303-KH	3/2 NC	0.6	0.12	0 ÷ 7
K000-303-FH	3/2 NC	0.6	0.12	0 ÷ 7

* add
 - VOLTAGE
 (see CODING EXAMPLE)

Series K solenoid valve - 3/2-way NO - 90° connector



Supplied with:
 1x interface for NO with position ports as per NC
 2x interface seals
 2x Ø1.6x19 screws for mounting on plastic
 or
 2x M1.6x19 screws for mounting on metal
 For use without port 1 and 3 inversion interface, use 16 mm long screws (see accessories)

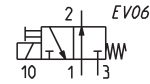
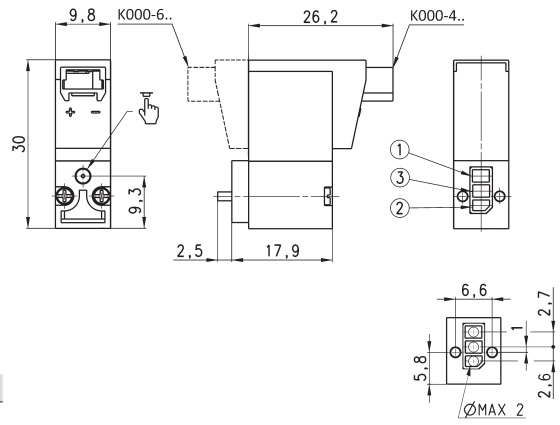

* add
 - VOLTAGE
 (see CODING EXAMPLE)

Mod.	Function	Orifice Ø (mm)	kv (l/min)	Min+max pressure (bar)
K000-403-K1	3/2 NO	0.8	0.20	0 ÷ 5
K000-403-F1	3/2 NO	0.8	0.20	0 ÷ 5
K000-403-K2	3/2 NO	0.8	0.20	0 ÷ 5
K000-403-F2	3/2 NO	0.8	0.20	0 ÷ 5
K000-403-K3	3/2 NO	0.8	0.20	0 ÷ 5
K000-403-F3	3/2 NO	0.8	0.20	0 ÷ 5

Series K solenoid valve - 3/2-way NO - in-line connector



Supplied with:
 1x interface for NO with position ports as per NC
 2x interface seals
 2x Ø1.6x19 screws for mounting on plastic
 or
 2x M1.6x19 screws for mounting on metal
 For use without port 1 and 3 inversion interface, use 16 mm long screws (see accessories)

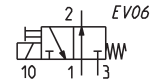
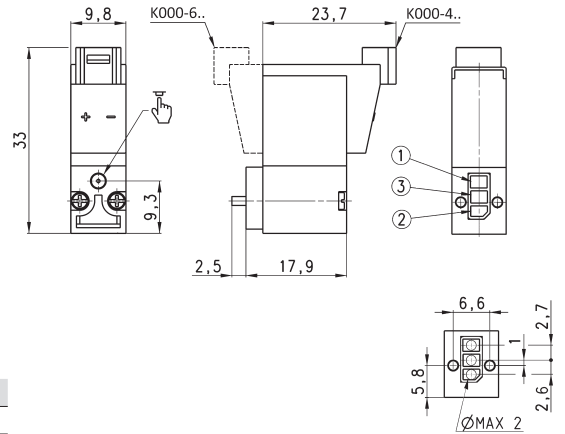

* add
 - VOLTAGE
 (see CODING EXAMPLE)

Mod.	Function	Orifice Ø (mm)	kv (l/min)	Min+max pressure (bar)
K000-403-KB	3/2 NO	0.8	0.20	0 ÷ 5
K000-403-FB	3/2 NO	0.8	0.20	0 ÷ 5
K000-403-KC	3/2 NO	0.8	0.20	0 ÷ 5
K000-403-FC	3/2 NO	0.8	0.20	0 ÷ 5
K000-403-KD	3/2 NO	0.8	0.20	0 ÷ 5
K000-403-FD	3/2 NO	0.8	0.20	0 ÷ 5

Series K solenoid valve - 3/2-way NO - 300 mm flying leads



Supplied with:
 1x interface for NO with position ports as per NC
 2x interface seals
 2x Ø1.6x19 screws for mounting on plastic
 or
 2x M1.6x19 screws for mounting on metal
 For use without port 1 and 3 inversion interface, use 16 mm long screws (see accessories)

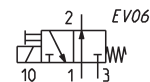
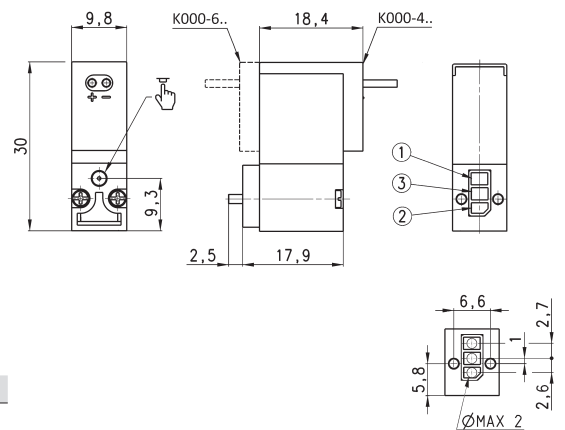

* add
 - VOLTAGE
 (see CODING EXAMPLE)

Mod.	Function	Orifice Ø (mm)	kv (l/min)	Min+max pressure (bar)
K000-403-KF	3/2 NO	0.8	0.20	0 ÷ 5
K000-403-FF	3/2 NO	0.8	0.20	0 ÷ 5
K000-403-KG	3/2 NO	0.8	0.20	0 ÷ 5
K000-403-FG	3/2 NO	0.8	0.20	0 ÷ 5
K000-403-KH	3/2 NO	0.8	0.20	0 ÷ 5
K000-403-FH	3/2 NO	0.8	0.20	0 ÷ 5

Single sub-base for solenoid valve size 10 mm

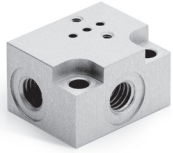

Single sub-base suitable for Series K 2-way or 3-way solenoid valve
Use solenoid valves with screws for mounting on metal (see coding)

Material: anodized aluminium
Connections: M5 threads

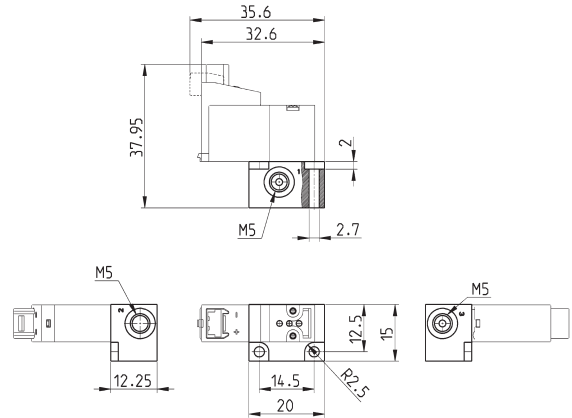

Mod.	
K001-02	

Manifold Mod. K1**-02



** Number of positions
With side outlets and conveyed inlet and exhaust.

Use solenoid valves with screws for mounting on metal (see coding)

Material: anodized aluminium
Connections: M5 threads

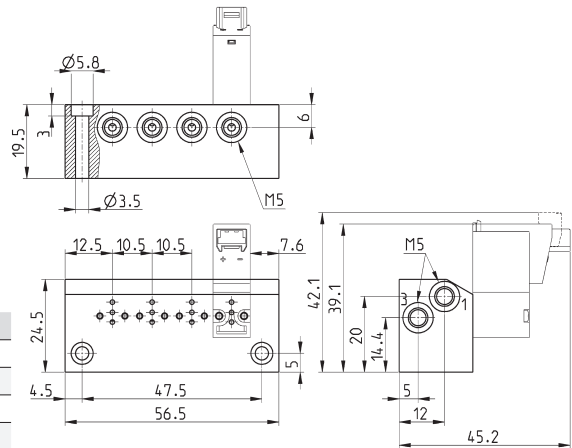

Mod.	A	B	Number of ports
K102-02	35.5	26.5	2
K103-02	46	37	3
K104-02	56.5	47.5	4
K105-02	67	58	5
K106-02	77.5	68.5	6
K107-02	88	79	7
K108-02	98.5	89.5	8
K109-02	109	100	9
K110-02	119.5	110.5	10

Position valve cap



Supplied with:
1x position valve cap
3x O-Rings
2x M1.6x6 screws for mounting on metal

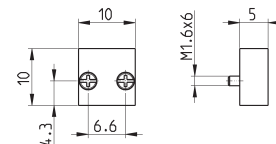

Mod.	
K000-TP	

Mounting screws for Series K solenoid valves



16 mm long screws for use with Series K 3/2-way NO solenoid valves without port 1 and 3 inversion interface

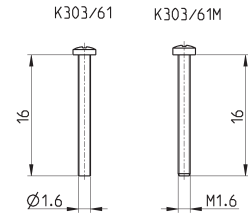

Mod.	
K303/61	Ø1.6x16 mm screw for mounting on plastic
K303/61M	M1.6x16 mm screw for mounting on metal

Connector with flying leads Mod. 121-8..

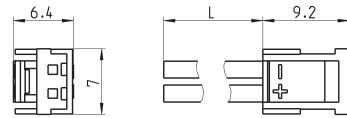

Mod.	description	colour	L = cable length (mm)	cable holding
121-803	crimped cable	black	300	crimping
121-806	crimped cable	black	600	crimping
121-810	crimped cable	black	1000	crimping
121-830	crimped cable	black	3000	crimping



Series KL - KLE directly operated solenoid valves

2/2-way - Normally Closed (NC)

3/2-way - Normally Closed (NC) and Normally Open (NO)

3/2-way - Universal (UNI)



The new Series KL and KLE 10 mm solenoid valves offer a range with improved models and performance compared to the previous generation. The possibility to use a longer coil allowed to increase the pressure values to which the valves can be submitted.

- » Application sectors:
 - Life Science
 - Industrial Automation
- » Compact design
- » High flow in proportion to the size
- » Extended version for higher performance
- » M8 - 3 pin electric connection available
- » Monostable and bistable manual override

GENERAL DATA

TECHNICAL FEATURES

Function	2/2 NC - 3/2 NC - 3/2 NO - 3/2 UNI
Operation	direct acting poppet type
Pneumatic connections	on subbase
Orifice diameter	0.6 ... 1.6 mm
Flow coefficient kv (l/min)	0.12 ... 0.50
Operating pressure	0 ÷ 3 ... 9 bar
Operating temperature	0 ÷ 50 °C
Media	filtered compressed air, unlubricated, according to ISO 8573-1 class 3.4.3, inert gas
Response time	ON <10 ms - OFF <10 ms
Manual override	monostable or bistable - only for 3/2 versions
Installation	in any position

MATERIALS IN CONTACT WITH THE MEDIUM

Body	PBT
Seals	FKM
Internal parts	stainless steel - brass

ELECTRICAL FEATURES

Voltage	6 ... 24 V DC - other voltages on demand
Voltage tolerance	±10%
Power consumption	1 W - 1.3/0.3 W - 4/1 W
Duty cycle	ED 100%
Electrical connection	connector mod. 121-8... - M8 connector mod. CS... (the M8 connection of the valve accepts polarity reversal)
Protection class	IP50 with connector 121-8... - IP65 with M8 connector

CODING EXAMPLE

KL	0	4	0	-	A6	3	A	Y	-	1	3	M
-----------	----------	----------	----------	----------	-----------	----------	----------	----------	----------	----------	----------	----------

KL	SERIES KL = standard KLE = extended
0	BODY DESIGN 0 = 3/2 body - ISO 15218 A = 3/2 body - ISO 15218 - coil rotated by 180° 2 = 2/2 body C = 2/2 body - coil rotated by 180°
4	NUMBER OF WAYS - FUNCTIONS 1 = 2/2-way NC 4 = 3/2-way NC 5 = 3/2-way NO 6 = 3/2-way UNI
0	PORTS 0 = on subbase or manifold
A6	ORIFICE DIAMETER A6 = Ø 0.60 mm A8 = Ø 0.80 mm B1 = Ø 1.10 mm B2 = Ø 1.20 mm B3 = Ø 1.30 mm B6 = Ø 1.60 mm
3	SEAL MATERIAL 3 = FKM
A	BODY MATERIAL A = PBT
Y	MANUAL OVERRIDE 0 = not requested or not foreseen Y = monostable B = bistable
1	ELECTRICAL CONNECTION 1 = 90° connection with protection and led B = in-line connection with protection and led M = M8 - 3 pin connection
3	VOLTAGE - POWER CONSUMPTION 1 = 6 V DC - 1 W 2 = 12 V DC - 1 W 3 = 24 V DC - 1 W A = 6 V DC - 1.3/0.3 W B = 12 V DC - 1.3/0.3 W C = 24 V DC - 1.3/0.3 W 5 = 5 V DC - 4/1 W 6 = 6 V DC - 4/1 W 7 = 12 V DC - 4/1 W 8 = 24 V DC - 4/1 W
M	FIXING M = fixing screws for metal P = fixing screws for plastic
	OPTIONS = standard OX1 = for use with oxygen (non volatile residual less than 550 mg/m ²)

Series KL solenoid valve - 2/2-way NC - 90° connector



Supplied with:
1x interface seal
2x M2x16 screws for mounting on metal

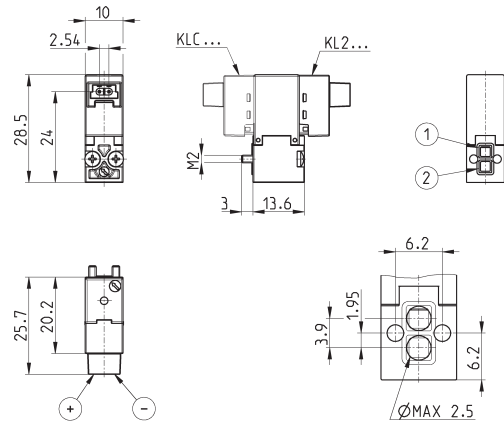

Mod.	Function	Orifice Ø (mm)	kv (l/min)	Pressure min ÷ max (bar)	Power (W)
KL210-A83A0-1°M	2/2 NC	0.8	0.25	0 ÷ 3	1.3 / 0.3
KL210-B23A0-1°M	2/2 NC	1.2	0.40	0 ÷ 6	4 / 1
KL210-B63A0-1°M	2/2 NC	1.6	0.50	0 ÷ 4	4 / 1
KLC10-A83A0-1°M	2/2 NC	0.8	0.25	0 ÷ 3	1.3 / 0.3
KLC10-B23A0-1°M	2/2 NC	1.2	0.40	0 ÷ 6	4 / 1
KLC10-B63A0-1°M	2/2 NC	1.6	0.50	0 ÷ 4	4 / 1

* add
- VOLTAGE
(see CODING EXAMPLE)



Series KL solenoid valve - 2/2-way NC - in-line connector



Supplied with:
1x interface seal
2x M2x16 screws for mounting on metal

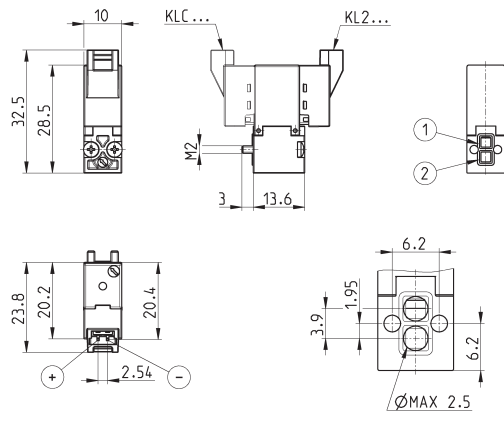

Mod.	Function	Orifice Ø (mm)	kv (l/min)	Pressure min ÷ max (bar)	Power (W)
KL210-A83A0-B°M	2/2 NC	0.8	0.25	0 ÷ 3	1.3 / 0.3
KL210-B23A0-B°M	2/2 NC	1.2	0.40	0 ÷ 6	4 / 1
KL210-B63A0-B°M	2/2 NC	1.6	0.50	0 ÷ 4	4 / 1
KLC10-A83A0-B°M	2/2 NC	0.8	0.25	0 ÷ 3	1.3 / 0.3
KLC10-B23A0-B°M	2/2 NC	1.2	0.40	0 ÷ 6	4 / 1
KLC10-B63A0-B°M	2/2 NC	1.6	0.50	0 ÷ 4	4 / 1

* add
- VOLTAGE
(see CODING EXAMPLE)



Series KLE solenoid valve - 2/2-way NC - 90° connector



Supplied with:
1x interface seal
2x M2x16 screws for mounting on metal

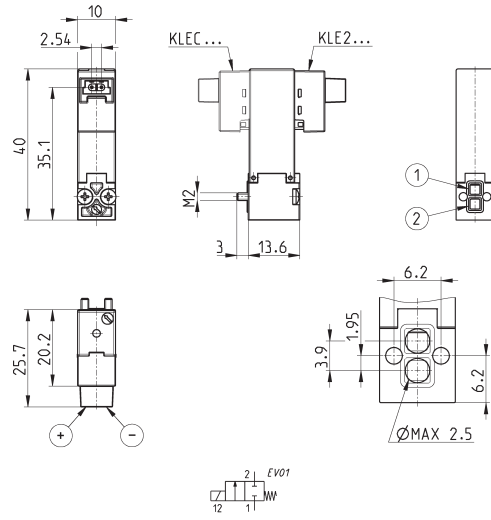

Mod.	Function	Orifice Ø (mm)	kv (l/min)	Pressure min ÷ max (bar)	Power (W)
KLE210-A83A0-1*M	2/2 NC	0.8	0.25	0 ÷ 5	1
KLE210-B23A0-1*M	2/2 NC	1.2	0.40	0 ÷ 8	4 / 1
KLE210-B63A0-1*M	2/2 NC	1.6	0.50	0 ÷ 6	4 / 1
KLEC10-A83A0-1*M	2/2 NC	0.8	0.25	0 ÷ 5	1
KLEC10-B23A0-1*M	2/2 NC	1.2	0.40	0 ÷ 8	4 / 1
KLEC10-B63A0-1*M	2/2 NC	1.6	0.50	0 ÷ 6	4 / 1

* add
- VOLTAGE
(see CODING EXAMPLE)

Series KLE solenoid valve - 2/2-way NC - in-line connector



Supplied with:
1x interface seal
2x M2x16 screws for mounting on metal

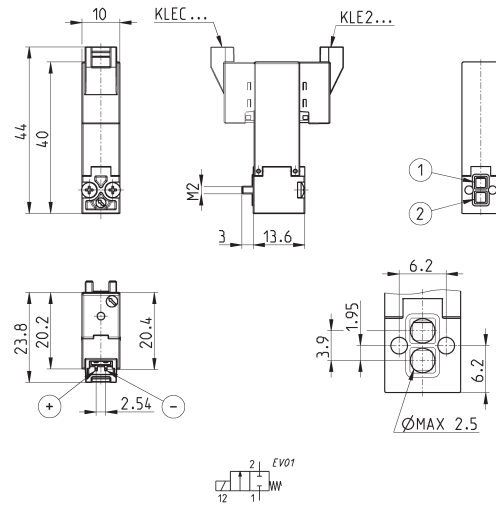

Mod.	Function	Orifice Ø (mm)	kv (l/min)	Pressure min ÷ max (bar)	Power (W)
KLE210-A83A0-B*M	2/2 NC	0.8	0.25	0 ÷ 5	1
KLE210-B23A0-B*M	2/2 NC	1.2	0.40	0 ÷ 8	4 / 1
KLE210-B63A0-B*M	2/2 NC	1.6	0.50	0 ÷ 6	4 / 1
KLEC10-A83A0-B*M	2/2 NC	0.8	0.25	0 ÷ 5	1
KLEC10-B23A0-B*M	2/2 NC	1.2	0.40	0 ÷ 8	4 / 1
KLEC10-B63A0-B*M	2/2 NC	1.6	0.50	0 ÷ 6	4 / 1

* add
- VOLTAGE
(see CODING EXAMPLE)

Series KLE solenoid valve - 2/2-way NC - M8 connector



Supplied with:
1x interface seal
2x M2x16 screws for mounting on metal

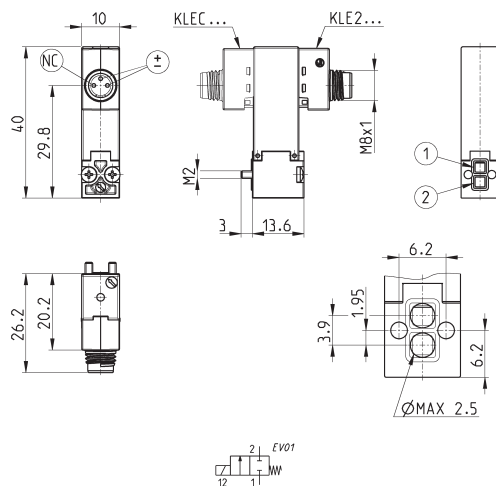

Mod.	Function	Orifice Ø (mm)	kv (l/min)	Pressure min ÷ max (bar)	Power (W)
KLE210-A83A0-M*M	2/2 NC	0.8	0.25	0 ÷ 5	1
KLEC10-A83A0-M*M	2/2 NC	0.8	0.25	0 ÷ 5	1

* add
- VOLTAGE
(see CODING EXAMPLE)

Series KL solenoid valve - 3/2-way - 90° connector



Supplied with:
 1x interface seal
 2x M1.6x14.7 screws for mounting on metal
 or
 2x Ø1.6x16 screws for mounting on plastic
 3/2 UNI models can work with vacuum. The maximum pressure will be reduced by 1 bar.

Mod.	Function	Orifice Ø (mm)	kv (l/min)	Pressure min ÷ max (bar)	Power (W)
KL ⁴⁰ -A63A [*] -1 ^{**}	3/2 NC	0.6	0.12	0 ÷ 7	1
KL ⁴⁰ -A83A [*] -1 ^{**}	3/2 NC	0.8	0.18	0 ÷ 5	1
KL ⁴⁰ -B13A [*] -1 ^{**}	3/2 NC	1.1	0.32	3 ÷ 7	4 / 1
KL ⁴⁰ -B33A [*] -1 ^{**}	3/2 NC	1.3	0.37	0 ÷ 3	4 / 1
KL ⁵⁰ -A63A [*] -1 ^{**}	3/2 NO	0.6	0.12	0 ÷ 7	1.3 / 0.3
KL ⁵⁰ -A83A [*] -1 ^{**}	3/2 NO	0.8	0.18	0 ÷ 5	1.3 / 0.3
KL ⁵⁰ -B13A [*] -1 ^{**}	3/2 NO	1.0	0.30	0 ÷ 5	4 / 1
KL ⁵⁰ -B33A [*] -1 ^{**}	3/2 NO	1.3	0.37	0 ÷ 3	4 / 1
KL ⁶⁰ -A63A [*] -1 ^{**}	3/2 UNI	0.6	0.12	0 ÷ 5 [-1 ÷ 4]	1.3 / 0.3
KL ⁶⁰ -A83A [*] -1 ^{**}	3/2 UNI	0.8	0.18	0 ÷ 2 [-1 ÷ 1]	1.3 / 0.3
KL ⁶⁰ -B13A [*] -1 ^{**}	3/2 UNI	1.1	0.30	0 ÷ 3 [-1 ÷ 2]	4 / 1
KL ⁶⁰ -B33A [*] -1 ^{**}	3/2 UNI	1.3	0.37	0 ÷ 2 [-1 ÷ 1]	4 / 1

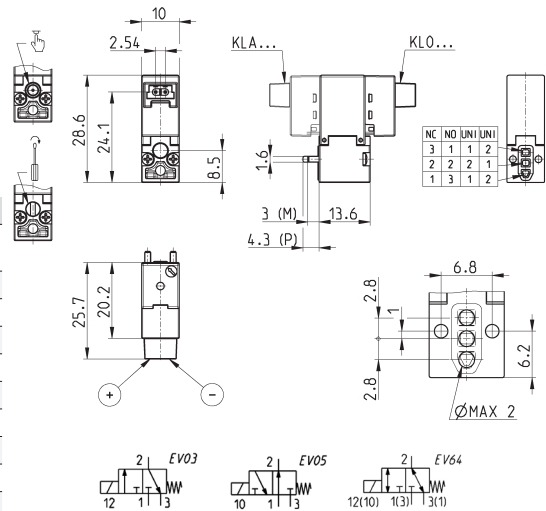

* add
 - BODY DESIGN
 - MANUAL OVERRIDE
 - VOLTAGE
 - FIXING
 (see CODING EXAMPLE)

Series KL solenoid valve - 3/2-way - in-line connector



Supplied with:
 1x interface seal
 2x M1.6x14.7 screws for mounting on metal
 or
 2x Ø1.6x16 screws for mounting on plastic
 3/2 UNI models can work with vacuum. The maximum pressure will be reduced by 1 bar.

Mod.	Function	Orifice Ø (mm)	kv (l/min)	Pressure min ÷ max (bar)	Power (W)
KL ⁴⁰ -A63A [*] -B ^{**}	3/2 NC	0.6	0.12	0 ÷ 7	1
KL ⁴⁰ -A83A [*] -B ^{**}	3/2 NC	0.8	0.18	0 ÷ 5	1
KL ⁴⁰ -B13A [*] -B ^{**}	3/2 NC	1.1	0.32	3 ÷ 7	4 / 1
KL ⁴⁰ -B33A [*] -B ^{**}	3/2 NC	1.3	0.37	0 ÷ 3	4 / 1
KL ⁵⁰ -A63A [*] -B ^{**}	3/2 NO	0.6	0.12	0 ÷ 7	1.3 / 0.3
KL ⁵⁰ -A83A [*] -B ^{**}	3/2 NO	0.8	0.18	0 ÷ 5	1.3 / 0.3
KL ⁵⁰ -B13A [*] -B ^{**}	3/2 NO	1.0	0.30	0 ÷ 5	4 / 1
KL ⁵⁰ -B33A [*] -B ^{**}	3/2 NO	1.3	0.37	0 ÷ 3	4 / 1
KL ⁶⁰ -A63A [*] -B ^{**}	3/2 UNI	0.6	0.12	0 ÷ 5 [-1 ÷ 4]	1.3 / 0.3
KL ⁶⁰ -A83A [*] -B ^{**}	3/2 UNI	0.8	0.18	0 ÷ 2 [-1 ÷ 1]	1.3 / 0.3
KL ⁶⁰ -B13A [*] -B ^{**}	3/2 UNI	1.1	0.30	0 ÷ 3 [-1 ÷ 2]	4 / 1
KL ⁶⁰ -B33A [*] -B ^{**}	3/2 UNI	1.3	0.37	0 ÷ 2 [-1 ÷ 1]	4 / 1

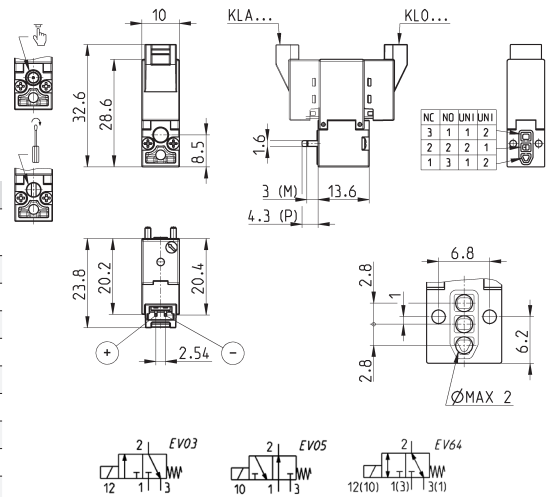

* add
 - BODY DESIGN
 - MANUAL OVERRIDE
 - VOLTAGE
 - FIXING
 (see CODING EXAMPLE)

Series KL solenoid valve - 3/2-way - M8 connector



Supplied with:
 1x interface seal
 2x M1.6x14.7 screws for mounting on metal
 or
 2x Ø1.6x16 screws for mounting on plastic

Mod.	Function	Orifice Ø (mm)	kv (l/min)	Pressure min ÷ max (bar)	Power (W)
KL ⁴⁰ -A63A [*] -M ^{**}	3/2 NC	0.6	0.12	0 ÷ 7	1
KL ⁴⁰ -A83A [*] -M ^{**}	3/2 NC	0.8	0.18	0 ÷ 5	1

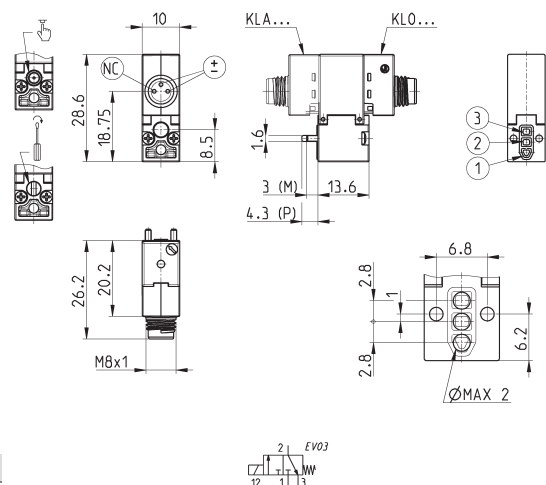

* add
 - BODY DESIGN
 - MANUAL OVERRIDE
 - VOLTAGE
 - FIXING
 (see CODING EXAMPLE)

Series KLE solenoid valve - 3/2-way - 90° connector



Supplied with:
1x interface seal
2x M1.6x14.7 screws for mounting on metal or
2x Ø1.6x16 screws for mounting on plastic
3/2 UNI models can work with vacuum. The maximum pressure will be reduced by 1 bar.

Mod.	Function	Orifice Ø (mm)	kv (l/min)	Pressure min ÷ max (bar)	Power (W)
KLE*40-A63A*-1**	3/2 NC	0.6	0.12	0 ÷ 9	1
KLE*40-A83A*-1**	3/2 NC	0.8	0.18	0 ÷ 7	1
KLE*40-B13A*-1**	3/2 NC	1.1	0.33	0 ÷ 7	4 / 1
KLE*40-B33A*-1**	3/2 NC	1.3	0.37	0 ÷ 4	4 / 1
KLE*50-A63A*-1**	3/2 NO	0.6	0.12	0 ÷ 9	1
KLE*50-A83A*-1**	3/2 NO	0.8	0.18	0 ÷ 7	1
KLE*50-B13A*-1**	3/2 NO	1.0	0.33	0 ÷ 7	4 / 1
KLE*50-B33A*-1**	3/2 NO	1.3	0.37	0 ÷ 4	4 / 1
KLE*60-A63A*-1**	3/2 UNI	0.6	0.12	0 ÷ 7 [-1 ÷ 6]	1
KLE*60-A83A*-1**	3/2 UNI	0.8	0.18	0 ÷ 4 [-1 ÷ 3]	1
KLE*60-B13A*-1**	3/2 UNI	1.1	0.33	0 ÷ 4 [-1 ÷ 3]	4 / 1
KLE*60-B33A*-1**	3/2 UNI	1.3	0.37	0 ÷ 3 [-1 ÷ 2]	4 / 1

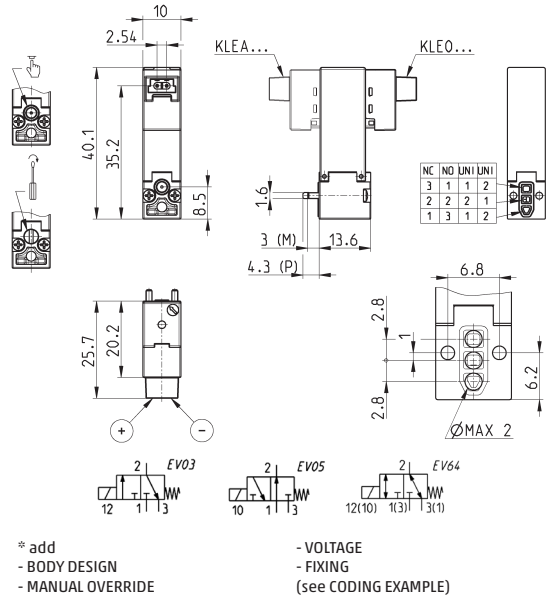

Series KLE solenoid valve - 3/2-way - in-line connector



Supplied with:
1x interface seal
2x M1.6x14.7 screws for mounting on metal or
2x Ø1.6x16 screws for mounting on plastic
3/2 UNI models can work with vacuum. The maximum pressure will be reduced by 1 bar.

Mod.	Function	Orifice Ø (mm)	kv (l/min)	Pressure min ÷ max (bar)	Power (W)
KLE*40-A63A*-B**	3/2 NC	0.6	0.12	0 ÷ 9	1
KLE*40-A83A*-B**	3/2 NC	0.8	0.18	0 ÷ 7	1
KLE*40-B13A*-B**	3/2 NC	1.1	0.33	0 ÷ 7	4 / 1
KLE*40-B33A*-B**	3/2 NC	1.3	0.37	0 ÷ 4	4 / 1
KLE*50-A63A*-B**	3/2 NO	0.6	0.12	0 ÷ 9	1
KLE*50-A83A*-B**	3/2 NO	0.8	0.18	0 ÷ 7	1
KLE*50-B13A*-B**	3/2 NO	1.0	0.30	0 ÷ 7	4 / 1
KLE*50-B33A*-B**	3/2 NO	1.3	0.37	0 ÷ 4	4 / 1
KLE*60-A63A*-B**	3/2 UNI	0.6	0.12	0 ÷ 7 [-1 ÷ 6]	1
KLE*60-A83A*-B**	3/2 UNI	0.8	0.18	0 ÷ 4 [-1 ÷ 3]	1
KLE*60-B13A*-B**	3/2 UNI	1.1	0.30	0 ÷ 4 [-1 ÷ 3]	4 / 1
KLE*60-B33A*-B**	3/2 UNI	1.3	0.37	0 ÷ 3 [-1 ÷ 2]	4 / 1

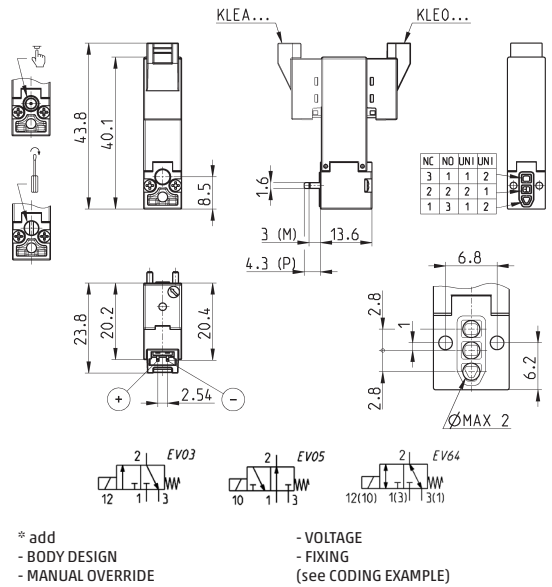

Series KLE solenoid valve - 3/2-way - M8 connector



Supplied with:
1x interface seal
2x M1.6x14.7 screws for mounting on metal or
2x Ø1.6x16 screws for mounting on plastic
3/2 UNI models can work with vacuum. The maximum pressure will be reduced by 1 bar.

Mod.	Function	Orifice Ø (mm)	kv (l/min)	Pressure min ÷ max (bar)	Power (W)
KLE*40-A63A*-M**	3/2 NC	0.6	0.12	0 ÷ 9	1
KLE*40-A83A*-M**	3/2 NC	0.8	0.18	0 ÷ 7	1
KLE*50-A63A*-M**	3/2 NO	0.6	0.12	0 ÷ 9	1
KLE*50-A83A*-M**	3/2 NO	0.8	0.18	0 ÷ 7	1
KLE*60-A63A*-M**	3/2 UNI	0.6	0.12	0 ÷ 7 [-1 ÷ 6]	1
KLE*60-A83A*-M**	3/2 UNI	0.8	0.18	0 ÷ 4 [-1 ÷ 3]	1

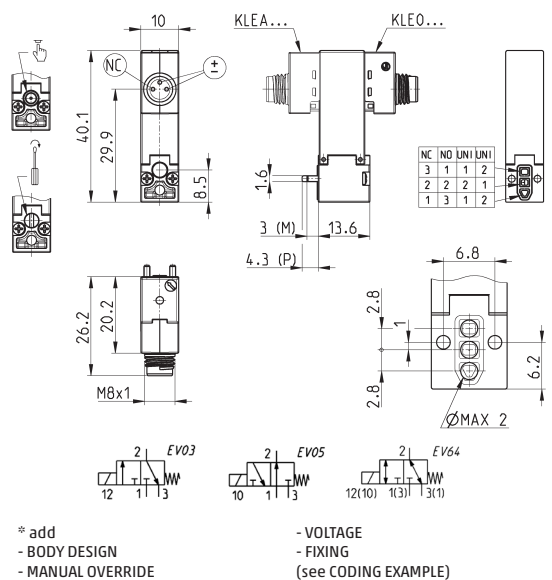

Single sub-base for 2-way solenoid valve size 10 mm

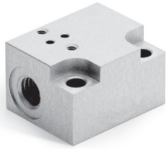

Single sub-base suitable for Series KL 2-way solenoid valve
Use solenoid valves with screws for mounting on metal (see coding)

Material: anodized aluminium
Connections: M5 threads

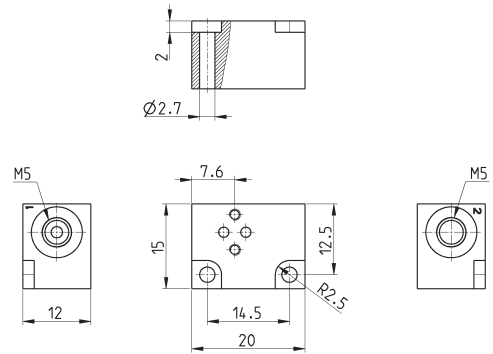

Mod.
KL01-02

Single sub-base for 3-way solenoid valve size 10 mm

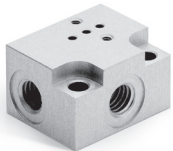

Single sub-base suitable for Series KN - KL - KLE 3-way solenoid valve
Use solenoid valves with screws for mounting on metal (see coding)

Material: anodized aluminium
Connections: M5 threads

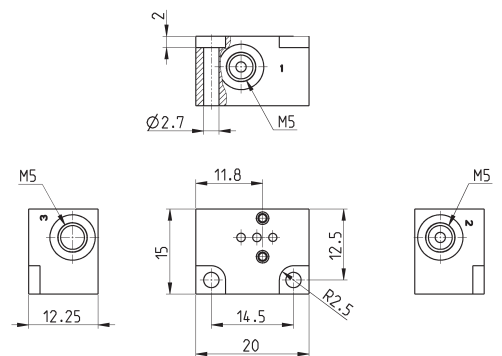

Mod.
KN01-02

Connector with flying leads Mod. 121-8..

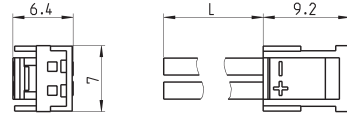
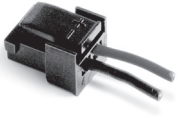

Mod.	description	colour	L = cable length (mm)	cable holding
121-803	crimped cable	black	300	crimping
121-806	crimped cable	black	600	crimping
121-810	crimped cable	black	1000	crimping
121-830	crimped cable	black	3000	crimping

3-wire extension with M8 3-pin female connector



With PU sheathing, non shielded cable.
Protection class: IP65

- 1 BN = Brown
- 4 BK = Black
- 3 BU = Blue

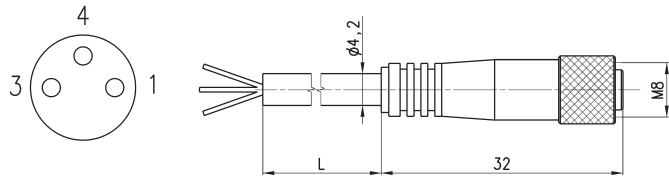

Mod.	L = cable length (m)
CS-2	2
CS-5	5
CS-10	10

Elettrovalvole a comando diretto Serie KN e KN High Flow

3/2 vie - Normalmente Chiusa (NC) e Normalmente Aperta (NO)
3/2 vie - Universale (UNI)

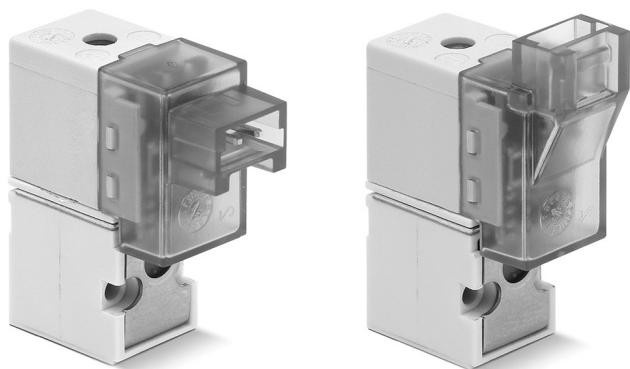

- » Basso consumo energetico
- » Design compatto
- » Portata elevata
- » Interfaccia ISO 15218
- » Disponibile versione per utilizzo con ossigeno

Per il suo basso consumo energetico e grazie al design compatto, l'elettrovalvola KN miniaturizzata trova impiego in applicazioni industriali e scientifiche.

Le elettrovalvole a comando diretto Serie KN sono disponibili anche nella versione ad alta portata (KN High Flow).

CARATTERISTICHE GENERALI

SPECIFICHE TECNICHE

Funzione	3/2 NC - 3/2 NO - 3/2 UNI
Azionamento	diretto ad otturatore
Connessioni pneumatiche	su sottobase interfaccia ISO 15218
Diametro orifizio	0.65 ... 1.1 mm
Coefficiente di flusso kv (l/min)	0.15 ... 0.39
Pressione di esercizio	0 ÷ 3 ... 7 bar
Temperatura di esercizio	0 ÷ 50 °C
Fluido	aria compressa filtrata e non lubrificata secondo ISO 8573-1 classe 3.4.3, gas inerti
Tempi di risposta	ON <10 ms - OFF <10 ms
Azionamento manuale	monostabile
Installazione	in qualsiasi posizione

MATERIALI IN CONTATTO CON IL FLUIDO

Corpo	PBT
Tenute	NBR - FKM
Parti interne	acciaio inox

SPECIFICHE ELETTRICHE

Tensione	5 ... 24 V DC - altre tensioni su richiesta
Tolleranza tensione	±10%
Potenza assorbita	1.3/0.25 ... 4/1 W (spunto/mantenimento)
Servizio continuo	ED 100%
Connessione elettrica	connettore mod. 121-8...
Grado di protezione	IP50

Esecuzioni speciali su richiesta

ESEMPIO DI CODIFICA

KN	0	00	-	3	0	3	-	K	1	3	
-----------	----------	-----------	----------	----------	----------	----------	----------	----------	----------	----------	--

KN	SERIE
0	ESECUZIONE CORPO 0 = valvola singola
00	NUMERO POSTI 00 = interfaccia
3	NUMERO VIE - FUNZIONI 3 = 3/2 vie - NC 4 = 3/2 vie - NO 7 = 3/2 vie - UNI
0	ATTACCHI 0 = ISO 15218 su sottobase o manifold
3	DIAMETRO ORIFIZIO 3 = Ø 0.65 mm 5 = Ø 1.1 mm - solo per versione NC con pressione minima richiesta per il funzionamento 6 = Ø 1.1 mm
K	MATERIALI F = corpo PBT - otturatore FKM - altre tenute FKM K = corpo PBT - otturatore FKM - altre tenute NBR
1	CONNESSIONE ELETTRICA 1 = connessione 90° con protezione e led B = connessione in linea con protezione e led
3	TENSIONE - POTENZA ASSORBITA 2 = 12 V DC - 1.3/0.25 W 3 = 24 V DC - 1.3/0.25 W 5 = 5 V DC - 4/1 W 7 = 12 V DC - 4/1 W 8 = 24 V DC - 4/1 W
	FISSAGGIO = viti di fissaggio per plastica M = viti di fissaggio per metallo
	OPZIONI = standard OX2 = per ossigeno (residuo non volatile inferiore a 33 mg/m³)

ELETTROVALVOLE SERIE KN E KN HIGH FLOW

Elettrovalvola KN - 3/2 vie - connettore a 90°



La fornitura comprende:
1x guarnizione interfaccia
2x viti Ø1.6x16 per fissaggio su plastica
oppure
2x viti M1.6x14.7 per fissaggio su metallo

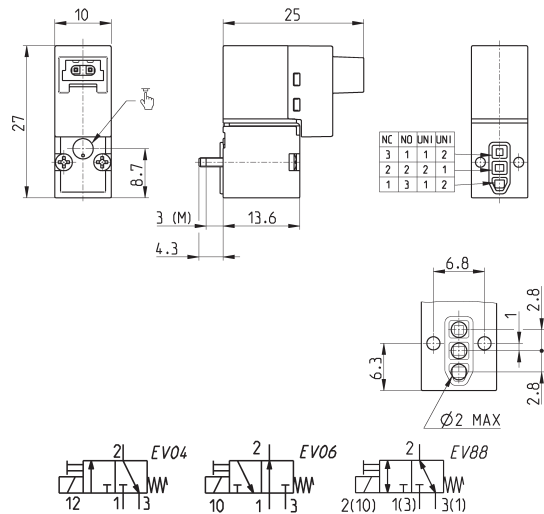

Mod.	Funzione	Orifizio Ø (mm)	kv (l/min)	Pressione min÷max (bar)	Potenza (W)	Simb.
KN000-303-K1*	3/2 NC	0.65	0.15	0 ÷ 7	1.3 / 0.25	EV04
KN000-303-F1*	3/2 NC	0.65	0.15	0 ÷ 7	1.3 / 0.25	EV04
KN000-305-F1*	3/2 NC	1.1	0.39	3 ÷ 7	4 / 1	EV04
KN000-306-F1*	3/2 NC	1.1	0.39	0 ÷ 3	4 / 1	EV04
KN000-403-F1*	3/2 NO	0.65	0.15	0 ÷ 7	1.3 / 0.25	EV05
KN000-703-F1*	3/2 UNI	0.65	0.15	0 ÷ 4	1.3 / 0.25	EV64
KN000-706-F1*	3/2 UNI	1.1	0.39	0 ÷ 1.5	4 / 1	EV64

* aggiungere
- TENSIONE
(vedi ESEMPIO CODIFICA)

Elettrovalvola KN - 3/2 vie - connettore in linea



La fornitura comprende:
 1x guarnizione interfaccia
 2x viti Ø1.6x16 per fissaggio su plastica
 oppure
 2x viti M1.6x14.7 per fissaggio su metallo

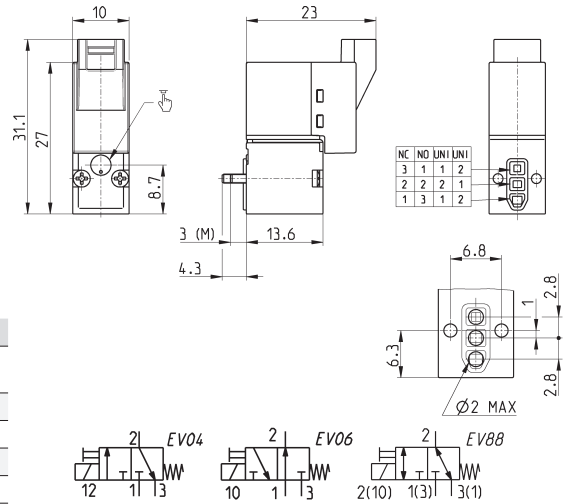

Mod.	Funzione	Orifizio Ø (mm)	kv (l/min)	Pressione min÷max (bar)	Potenza (W)	Simb.
KN000-303-KB*	3/2 NC	0.65	0.15	0 ÷ 7	1.3 / 0.25	EV04
KN000-303-FB*	3/2 NC	0.65	0.15	0 ÷ 7	1.3 / 0.25	EV04
KN000-305-FB*	3/2 NC	1.1	0.39	3 ÷ 7	4 / 1	EV04
KN000-306-FB*	3/2 NC	1.1	0.39	0 ÷ 3	4 / 1	EV04
KN000-403-FB*	3/2 NO	0.65	0.15	0 ÷ 7	1.3 / 0.25	EV05
KN000-703-FB*	3/2 UNI	0.65	0.15	0 ÷ 4	1.3 / 0.25	EV64
KN000-706-FB*	3/2 UNI	1.1	0.39	0 ÷ 1.5	4 / 1	EV64

* aggiungere
 - TENSIONE
 (vedi ESEMPIO CODIFICA)

Sottobase singola per elettrovalvole taglia 10 mm a 3 vie

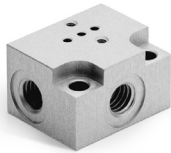

Sottobase singola idonea per elettrovalvole a 3 vie delle Serie KN - KL - KLE
 Utilizzare elettrovalvole con viti per fissaggio su metallo (vedi pag. codifica)

Materiale : alluminio anodizzato
 Connessioni : filettature M5

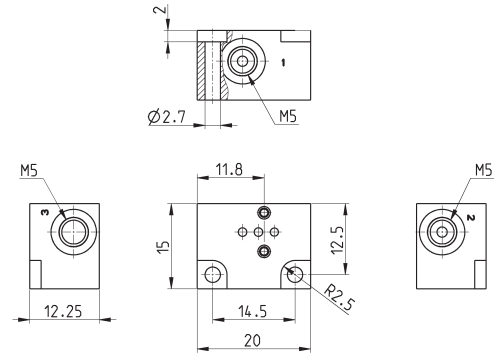

Mod.
KN01-02

Connettore con cavetti Mod. 121-8...

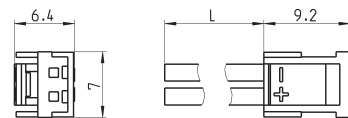

Mod.	descrizione	colore	L = lunghezza cavo (mm)	trattenimento cavo
121-803	cavo crimpato	nero	300	crimpatura
121-806	cavo crimpato	nero	600	crimpatura
121-810	cavo crimpato	nero	1000	crimpatura
121-830	cavo crimpato	nero	3000	crimpatura

Esempio di VERSIONE MANIFOLD SERIE KN - Max 16 posizioni su richiesta

Pneumatica ed elettronica integrate
Funzioni valvola: 2x2/2 - 2x3/2
Modularità pneumatica
Passo valvole 10 mm

Diverse soluzioni di connessione elettrica.
Possibilità di collegamento con moduli per ingressi digitali.

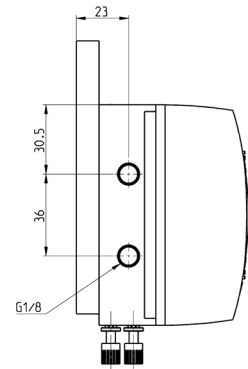
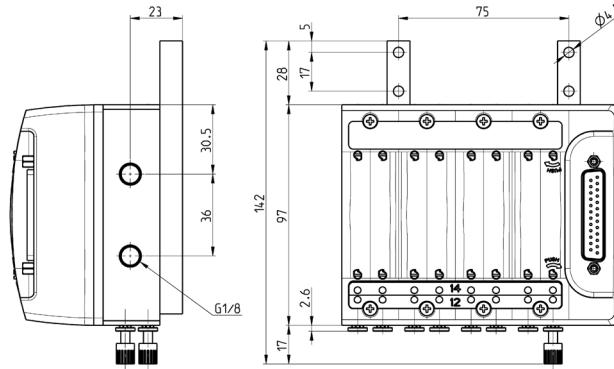
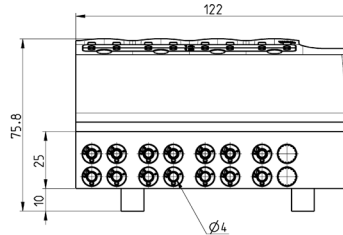
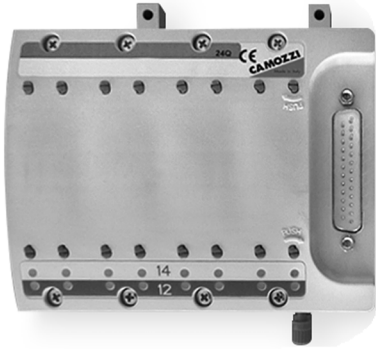

CARATTERISTICHE TECNICHE

Connessioni pneumatiche	pinza tubo Ø 4 mm
Diametro nominale	0.65 mm
Portata nominale	10 NI/min (singola elettrovalvola)
Pressione di esercizio	0 ÷ 7 bar
Temperatura di esercizio	0 ÷ +50°C
Fluido	aria filtrata classe 5.4.4 secondo ISO 8573-1 (viscosità olio max. 32 cSt), gas inerti

Tenute	HNBR, NBR (FKM su richiesta)
---------------	------------------------------

Tensione	24 V DC
Tolleranza tensione	±10%
Assorbimento	1.3 W (spunto), 0.25 W (mantenimento)
Servizio continuo	ED 100%
Connessione elettrica	Multipolare-PNP / Punto-Punto / Seriale

Series W directly operated solenoid valves

3/2-way - Normally Closed (NC) and Normally Open (NO)

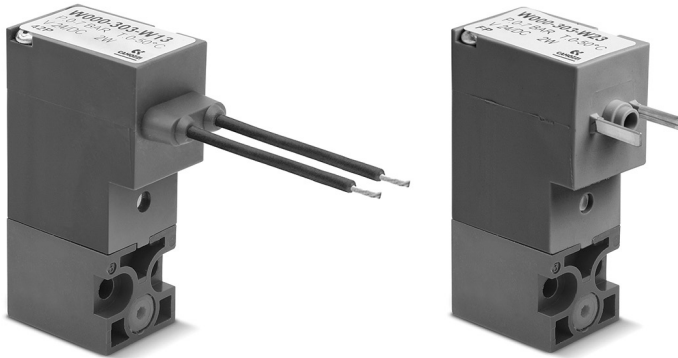

- » Can be mounted on a single base (M5 connections) or on manifold (M5 connections or fittings for Ø3 or Ø4 tube).
- » Electrical connection with flying leads or in compliance to DIN EN 175 301-803-C standard

Series W directly operated solenoid valves are available as 3/2-way either NC or NO. Both versions can be mounted on single sub-bases or manifolds and they are equipped with a monostable manual override.

GENERAL DATA

TECHNICAL FEATURES

Function	3/2 NC - 3/2 NO
Operation	direct acting poppet type
Pneumatic connections	on subbase with ISO 15218 interface
Orifice diameter	0.8 ... 1.5 mm
Flow coefficient kv (l/min)	0.21 ... 0.54
Operating pressure	0 ÷ 5 ... 10 bar
Operating temperature	0 ÷ 50 °C
Media	filtered air, class 5.4.4 according to ISO 8573-1 (max oil viscosity 32 cSt), inert gas
Response time (ISO 12238)	ON <10 ms - OFF <15 ms
Manual override	monostable
Installation	in any position

MATERIALS IN CONTACT WITH THE MEDIUM

Body	PBT
Seals	PU - NBR - FKM - EPDM
Internal parts	stainless steel

ELECTRICAL FEATURES

Voltage	12 ... 48 V DC - other voltages on demand
Voltage tolerance	±10%
Power consumption	2 W - 1 W (24 V DC only)
Duty cycle	ED 100%
Electrical connection	connector DIN EN 175 301-803-C (8 mm) - 300 mm flying leads
Protection class	IP65 with connector

Special versions available on demand

CODING EXAMPLE

W	0	00	-	3	0	3	-	W	2	3	
----------	----------	-----------	----------	----------	----------	----------	----------	----------	----------	----------	--

W	SERIES
0	<p>BODY DESIGN 0 = single sub-base (only M5) or interface 1 = single manifold 2 = double manifold</p>
00	<p>NUMBER OF POSITIONS 00 = ISO 15218 interface 01 = single base (M5 only) 02 ÷ 99 = manifold number of positions</p>
3	<p>NUMBER OF WAYS - FUNCTIONS 0 = manifold or single sub-base 3 = 3/2-way - NC 4 = 3/2-way - NO 5 = 3/2-way - NC electric part revolved by 180° 6 = 3/2-way - NO electric part revolved by 180°</p>
0	<p>VALVE PORTS 0 = ISO 15218 interface</p> <p>MANIFOLD PORTS for P - PL - PN - W Series 2 = M5 thread - front outlets 3 = tube Ø 3 mm fittings - front outlets 4 = tube Ø 4 mm fittings - front outlets 6 = M5 thread - bottom outlets 7 = tube Ø 3 mm fittings - bottom outlets 8 = tube Ø 4 mm fittings - bottom outlets</p>
3	<p>ORIFICE DIAMETER 1 = Ø 0.8 mm 3 = Ø 1.5 mm 5 = Ø 1.1 mm - NC versions 6 = Ø 1.5 mm - NC versions with voltage tolerance -25% ÷ +10% 5 = Ø 0.9 mm - NO versions</p>
W	<p>MATERIALS E = PBT body - EPDM seals F = PBT body - FKM seals W = PBT body - NBR - FKM - PU seals</p>
2	<p>ELECTRICAL CONNECTION 1 = 300 mm flying leads 2 = DIN EN 175 301-803-C (8 mm)</p>
3	<p>VOLTAGE - POWER CONSUMPTION 2 = 12 V DC - 2 W 3 = 24 V DC - 1 W - NC Ø 0.8 mm version only 3 = 24 V DC - 2 W 4 = 48 V DC - 2 W</p>
	<p>FIXING = fixing screws for metal P = fixing screws for plastic</p>
	<p>OPTIONS: = standard OX1 = for use with oxygen (non volatile residual less than 550 mg/m²) OX2 = for use with oxygen (non volatile residual less than 33 mg/m²)</p>

Series W solenoid valve - 3/2-way NC - DIN EN 175 301-803-C (8 mm)



Supplied with:
 1x interface seal
 2x M3x20 screws for mounting on metal
 or
 2x Ø3x23 screws for mounting on plastic

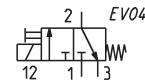
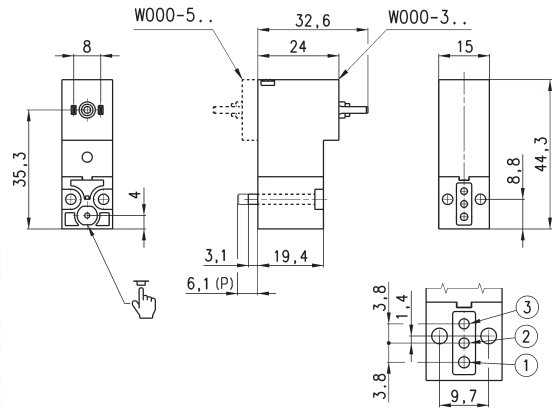

(see CODING EXAMPLE)

* add
 - MATERIALS
 - VOLTAGE

Mod.	Function	Orifice Ø (mm)	kv (l/min)	Min÷max pressure (bar)	Power (W)
W000-301- [*] 23	3/2 NC	0.8	0.21	0 ÷ 10	1
W000-305- [*] 2*	3/2 NC	1.1	0.39	0 ÷ 10	2
W000-303- [*] 2*	3/2 NC	1.5	0.54	0 ÷ 7	2
W000-306- [*] 2*	3/2 NC	1.5	0.39	0 ÷ 3	2
W000-501- [*] 23	3/2 NC	0.8	0.21	0 ÷ 10	1
W000-505- [*] 2*	3/2 NC	1.1	0.39	0 ÷ 10	2
W000-503- [*] 2*	3/2 NC	1.5	0.54	0 ÷ 7	2
W000-506- [*] 2*	3/2 NC	1.5	0.39	0 ÷ 3	2
W000-303-W22	3/2 NC	1.5	0.54	0 ÷ 7	2
W000-306-W23	3/2 NC	1.5	0.39	0 ÷ 3	2

Series W solenoid valve - 3/2-way NO - DIN EN 175 301-803-C (8 mm)



Supplied with:
 1x interface for NO with position ports as per NC (ports 1 and 3 are inverted)
 2x interface seals
 2x M3x25 screws for mounting on metal

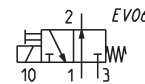
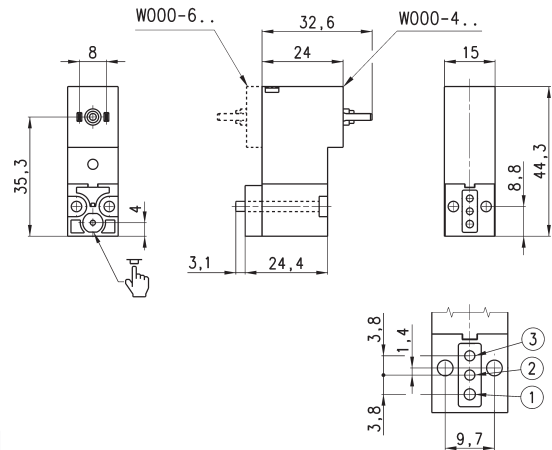

(see CODING EXAMPLE)

* add
 - MATERIALS
 - VOLTAGE

Mod.	Function	Orifice Ø (mm)	kv (l/min)	Min÷max pressure (bar)	Power (W)
W000-405- [*] 2*	3/2 NO	0.9	0.23	0÷10	2
W000-403- [*] 2*	3/2 NO	1.5	0.39	0÷5	2
W000-605- [*] 2*	3/2 NO	0.9	0.23	0÷10	2
W000-603- [*] 2*	3/2 NO	1.5	0.39	0÷5	2

Series W solenoid valve - 3/2-way NC - 300 mm flying leads

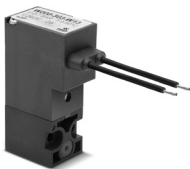

Supplied with:
 1x interface seal
 2x M3x20 screws for mounting on metal
 or
 2x Ø3x23 screws for mounting on plastic

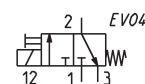
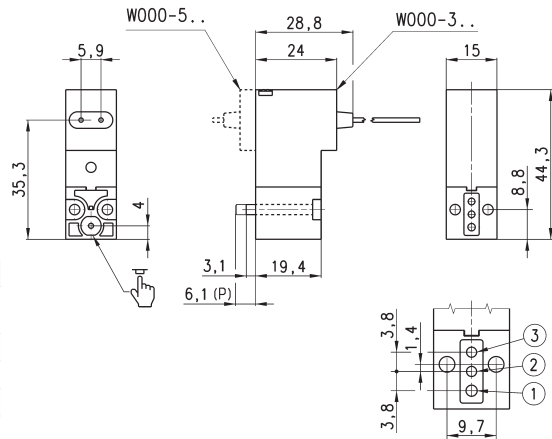

(see CODING EXAMPLE)

* add
 - MATERIALS
 - VOLTAGE

Mod.	Function	Orifice Ø (mm)	kv (l/min)	Min÷max pressure (bar)	Power (W)
W000-301- [*] 13*	3/2 NC	0.8	0.21	0÷10	1
W000-305- [*] 1*	3/2 NC	1.1	0.39	0÷10	2
W000-303- [*] 1*	3/2 NC	1.5	0.54	0÷7	2
W000-306- [*] 1*	3/2 NC	1.5	0.39	0÷3	2
W000-501- [*] 13	3/2 NC	0.8	0.21	0÷10	1
W000-505- [*] 1*	3/2 NC	1.1	0.39	0÷10	2
W000-503- [*] 1*	3/2 NC	1.5	0.54	0÷7	2
W000-506- [*] 1*	3/2 NC	1.5	0.39	0÷3	2
W000-303-W12	3/2 NC	1.5	0.54	1.5	2
W000-305-W12	3/2 NC	1.1	0.39	0÷10	2

Series W solenoid valve - 3/2-way NO - 300 mm flying leads

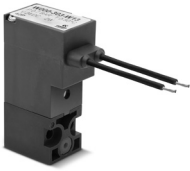

Supplied with:
1x interface for NO with position ports as per NC (ports 1 and 3 are inverted)
2x interface seals
2x M3x25 screws for mounting on metal

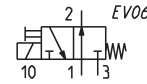
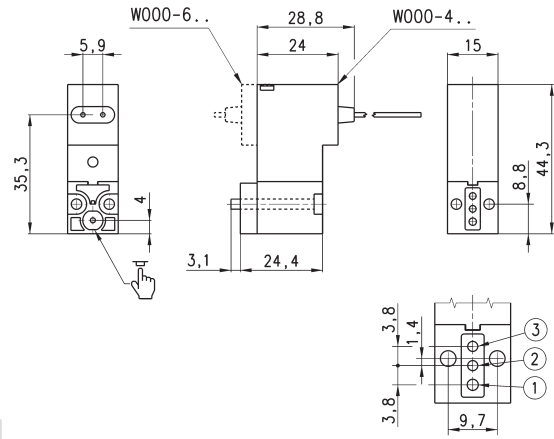

(see CODING EXAMPLE)

* add
- MATERIALS
- VOLTAGE

Mod.	Function	Orifice Ø (mm)	kv (l/min)	Min÷max pressure (bar)	Power (W)
W000-405- [*] 1 [*]	3/2 NO	0.9	0.23	0÷10	2
W000-403- [*] 1 [*]	3/2 NO	1.5	0.39	0÷5	2
W000-605- [*] 1 [*]	3/2 NO	0.9	0.23	0÷10	2
W000-603- [*] 1 [*]	3/2 NO	1.5	0.39	0÷5	2

Single sub-base for 3-way solenoid valve size 15 mm



Single sub-base suitable for Series P - PL - PN - W 3-way solenoid valve
Use solenoid valves with screws for mounting on metal (see coding)

Material: anodized aluminium
Connections: M5 threads

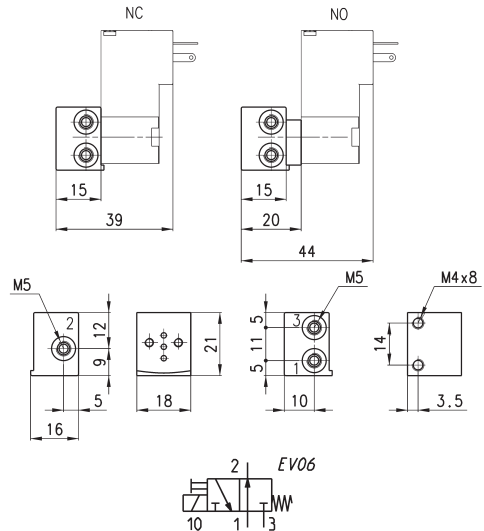

Mod.	P001-02
------	---------

Manifold - single side valve - bottom outlets



Manifold suitable for Series P - PL - PN - W 3-way solenoid valve
Use solenoid valves with screws for mounting on metal (see coding)

Material: anodized aluminium

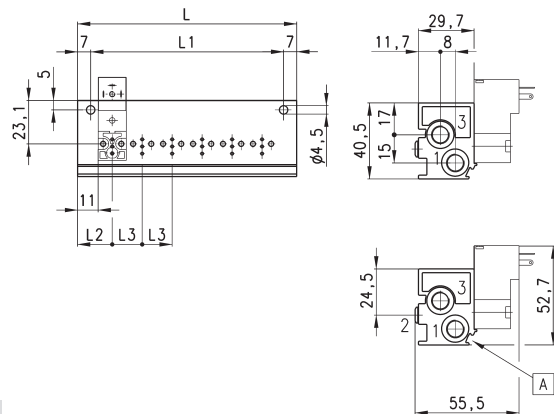

DIMENSIONS							
Mod.	Positions	L	L1	L2	L3	1 (P)	3 (R)
P102-0 [*]	2	53	39	18,5	16	G1/8	G1/8
P103-0 [*]	3	69	55	18,5	16	G1/8	G1/8
P104-0 [*]	4	85	71	18,5	16	G1/8	G1/8
P105-0 [*]	5	101	87	18,5	16	G1/8	G1/8
P106-0 [*]	6	117	103	18,5	16	G1/8	G1/8

* add
- MANIFOLD PORTS
(see CODING EXAMPLE)

A= groove for identification label

Manifold - single side valve - frontal outlets



Manifold suitable for Series P - PL - PN - W
3-way solenoid valve
Use solenoid valves with screws for mounting on metal (see coding)

Can be fixed through DIN 46277/3 guide with the accessory PCF-E520.

Material: anodized aluminium

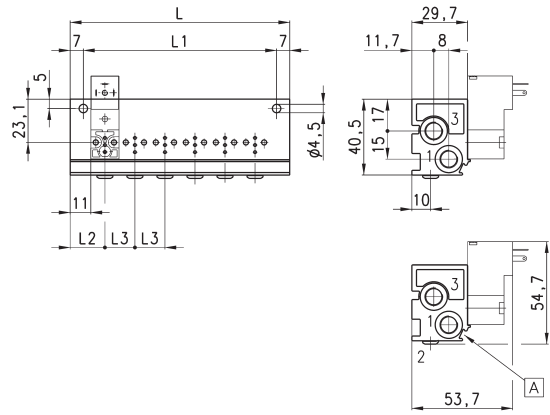

DIMENSIONS							
Mod.	Positions	L	L1	L2	L3	1 (P)	3 (R)
P102-0*	2	53	39	18,5	16	G1/8	G1/8
P103-0*	3	69	55	18,5	16	G1/8	G1/8
P104-0*	4	85	71	18,5	16	G1/8	G1/8
P105-0*	5	101	87	18,5	16	G1/8	G1/8
P106-0*	6	117	103	18,5	16	G1/8	G1/8

* add
- MANIFOLD PORTS
(see CODING EXAMPLE)

A= groove for identification label

Manifold - double side valve - bottom outlets



Manifold suitable for Series P - PL - PN - W
3-way solenoid valve
Use solenoid valves with screws for mounting on metal (see coding)

Material: anodized aluminium

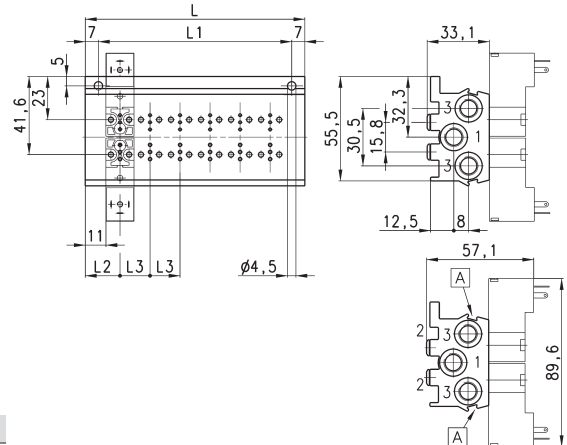

DIMENSIONS							
Mod.	Positions	L	L1	L2	L3	1 (P)	3 (R)
P204-0*	4	53	39	18,5	16	G1/8	G1/8
P206-0*	6	69	55	18,5	16	G1/8	G1/8
P208-0*	8	85	71	18,5	16	G1/8	G1/8
P210-0*	10	101	87	18,5	16	G1/8	G1/8
P212-0*	12	117	103	18,5	16	G1/8	G1/8

* add
- MANIFOLD PORTS
(see CODING EXAMPLE)

A= groove for identification label

Manifold - double side valve - frontal outlets



Manifold suitable for Series P - PL - PN - W
3-way solenoid valve
Use solenoid valves with screws for mounting on metal (see coding)

Can be fixed through DIN 46277/3 guide with the accessory PCF-E520.

Material: anodized aluminium

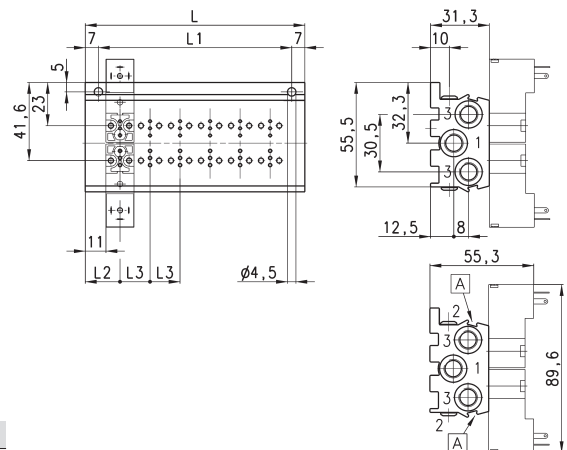

DIMENSIONS							
Mod.	Positions	L	L1	L2	L3	1 (P)	3 (R)
P204-0*	4	53	39	18,5	16	G1/8	G1/8
P206-0*	6	69	55	18,5	16	G1/8	G1/8
P208-0*	8	85	71	18,5	16	G1/8	G1/8
P210-0*	10	101	87	18,5	16	G1/8	G1/8
P212-0*	12	117	103	18,5	16	G1/8	G1/8

* add
- MANIFOLD PORTS
(see CODING EXAMPLE)

A= groove for identification label

Position valve cap



Supplied with:
1x position valve cap
1x interface seal
2x screws

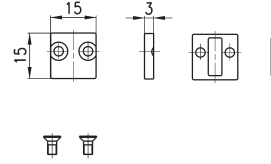

Mod.	
P000-TP	

1 = 90° adjustable connector

Connector Mod. 126-... - DIN EN 175 301-803-C (8 mm)

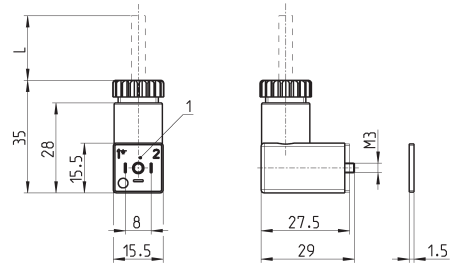

Mod.	description	colour	working voltage	cable length [L]	cable gland	tightening torque
126-550-1	moulded cable, without electronics	black	-	1000 mm	-	0.3 Nm
126-800	connector, without electronics	black	-	-	PG7	0.3 Nm
126-701	connector, varistor + Led	transparent	24 V AC/DC	-	PG7	0.3 Nm

1 = 90° adjustable connector

Series P directly operated solenoid valves

3/2-way - Normally Closed (NC) and Normally Open (NO)

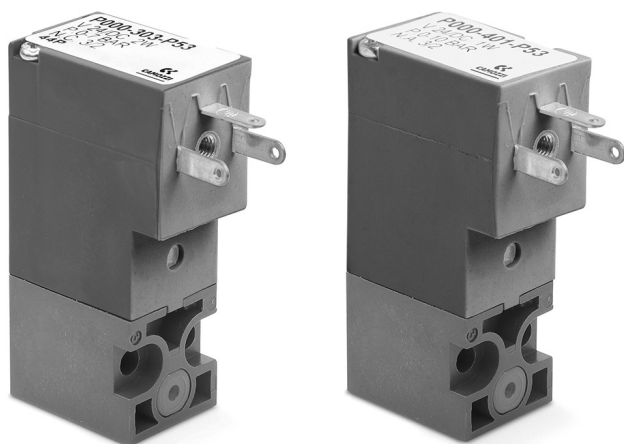

» Can be mounted on a single base (M5 connections) or on manifold (M5 connections or fittings for Ø3 or Ø4 tube).

Series P directly operated solenoid valves are available as 3/2-way, either NC or NO. Both versions can be mounted on single sub-bases or manifolds and they are equipped with a monostable manual override.

Please note that all Series P solenoid valves are supplied with direct current (DC). To operate in alternating current (AC), it is necessary to use the connector with bridge rectifier Mod. 125-900.

GENERAL DATA

TECHNICAL FEATURES

Function	3/2 NC - 3/2 NO
Operation	direct acting poppet type
Pneumatic connections	on subbase with ISO 15218 interface
Orifice diameter	0.8 ... 1.5 mm
Flow coefficient kv (l/min)	0.21 ... 0.54
Operating pressure	0 ÷ 3 ... 10 bar
Operating temperature	0 ÷ 50 °C
Media	filtered air, class 5.4.4 according to ISO 8573-1 (max oil viscosity 32 cSt), inert gas
Response time (ISO 12238)	ON <10 ms - OFF <15 ms
Manual override	monostable
Installation	in any position

MATERIALS IN CONTACT WITH THE MEDIUM

Body	PBT
Seals	PU - NBR - FKM - EPDM
Internal parts	stainless steel

ELECTRICAL FEATURES

Voltage	12 ... 110 V DC - 24 ... 110 V AC 50/60 Hz - other voltages on demand
Voltage tolerance	±10%
Power consumption	1 ... 2 W
Duty cycle	ED 100%
Electrical connection	industrial standard connector (9.4 mm)
Protection class	IP65 with connector

Special versions available on demand

CODING EXAMPLE

P	0	00	-	3	0	3	-	P	5	3	
----------	----------	-----------	----------	----------	----------	----------	----------	----------	----------	----------	--

P	SERIES
0	BODY DESIGN 0 = single sub-base (M5 only) or interface 1 = single manifold 2 = double sided manifold
00	NUMBER OF POSITIONS 00 = ISO 15218 interface 01 = single base (M5 only) 02 ÷ 99 = manifold number of positions
3	NUMBER OF WAYS - FUNCTIONS 0 = manifold or single base 3 = 3/2-way - NC 4 = 3/2-way - NO 5 = 3/2-way - NC electric part revolved by 180° 6 = 3/2-way - NO electric part revolved by 180°
0	VALVE PORTS 0 = ISO 15218 interface MANIFOLD PORTS for P - PL - PN - W Series 2 = M5 thread - front outlets 3 = tube Ø 3 mm fittings - front outlets 4 = tube Ø 4 mm fittings - front outlets 6 = M5 thread - bottom outlets 7 = tube Ø 3 mm fittings - bottom outlets 8 = tube Ø 4 mm fittings - bottom outlets
3	ORIFICE DIAMETER 1 = Ø 0.8 mm 3 = Ø 1.5 mm 5 = Ø 1.1 mm - NC versions 6 = Ø 1.5 mm - NC versions with voltage tolerance -25% ÷ +10% 5 = Ø 0.9 mm - NO versions
P	MATERIALS E = PBT body - EPDM seals F = PBT body - FKM seals P = PBT body - NBR - FKM - PU seals
5	ELECTRICAL CONNECTION 5 = industrial standard (9.4 mm)
3	VOLTAGE - POWER CONSUMPTION 2 = 12 V DC - 2 W (1 W only for NC - Ø 0.8 mm version) B = 24 V 50/60 Hz - 2 W 3 = 24 V DC - 2 W (1 W only for NC - Ø 0.8 mm version) C = 48 V 50/60 Hz - 2 W 4 = 48 V DC - 2 W D = 110 V 50/60 Hz - 2 W 6 = 110 V DC - 2 W
	FIXING = fixing screws for metal P = fixing screws for plastic
	OPTIONS = standard OX1 = for use with oxygen (non volatile residual less than 550 mg/m ²) OX2 = for use with oxygen (non volatile residual less than 33 mg/m ²)

Series P solenoid valve - 3/2-way NC



Supplied with:
 1x interface seal
 2x M3x20 screws for mounting on metal
 or
 2x Ø3x23 screws for mounting on plastic

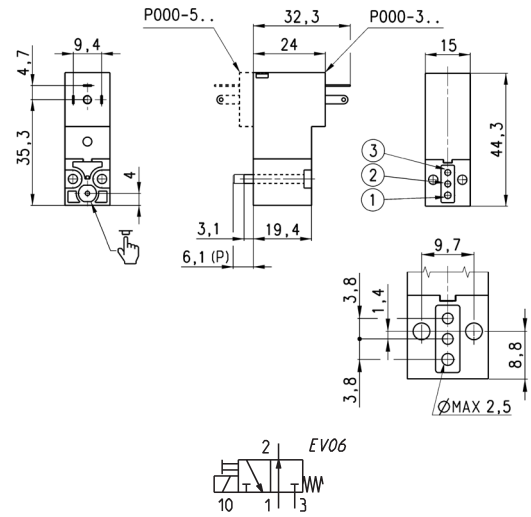

Mod.	Function	Orifice Ø (mm)	kv (l/min)	Min÷max pressure (bar)	Power (W)
P000-301-5*	3/2 NC	0.8	0.21	0 ÷ 10	1
P000-305-5*	3/2 NC	1.1	0.39	0 ÷ 10	2
P000-303-5*	3/2 NC	1.5	0.54	0 ÷ 7	2
P000-306-5*	3/2 NC	1.5	0.54	0 ÷ 3	2
P000-501-5*	3/2 NC	0.8	0.21	0 ÷ 10	1
P000-505-5*	3/2 NC	1.1	0.39	0 ÷ 10	2
P000-503-5*	3/2 NC	1.5	0.54	0 ÷ 7	2
P000-506-5*	3/2 NC	1.5	0.39	0 ÷ 3	2

* add
 - MATERIALS
 - VOLTAGE
 (see CODING EXAMPLE)

Series P solenoid valve - 3/2-way NO



Supplied with:
 1x interface for NO with position ports as per NC (ports 1 and 3 are inverted)
 2x interface seals
 2x M3x25 screws for mounting on metal

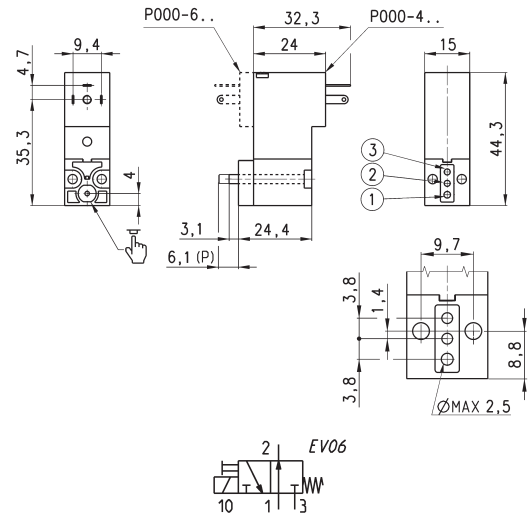

Mod.	Function	Orifice Ø (mm)	kv (l/min)	Min÷max pressure (bar)	Power (W)
P000-405-5*	3/2 NO	0.9	0.23	0 ÷ 10	2
P000-403-5*	3/2 NO	1.5	0.39	0 ÷ 5	2
P000-605-5*	3/2 NO	0.9	0.23	0 ÷ 10	2
P000-603-5*	3/2 NO	1.5	0.39	0 ÷ 5	2

* add
 - MATERIALS
 - VOLTAGE
 (see CODING EXAMPLE)

Single sub-base for 3-way solenoid valve size 15 mm



Single sub-base suitable for Series P - PL - PN - W 3-way solenoid valve
 Use solenoid valves with screws for mounting on metal (see coding)

Material: anodized aluminium
 Connections: M5 threads

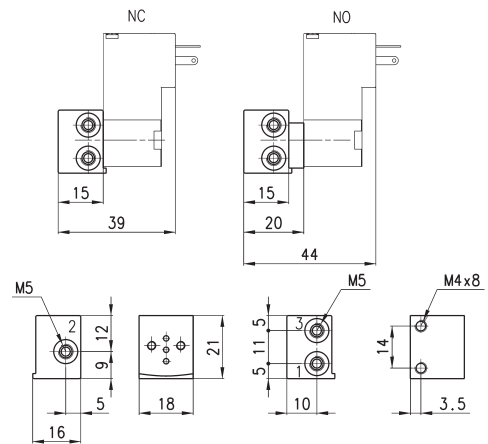

Mod.
P001-02

Manifold - double side valve - frontal outlets



Manifold suitable for Series P - PL - PN - W 3-way solenoid valve
Use solenoid valves with screws for mounting on metal (see coding)

Can be fixed through DIN 46277/3 guide with the accessory PCF-E520.

Material: anodized aluminium

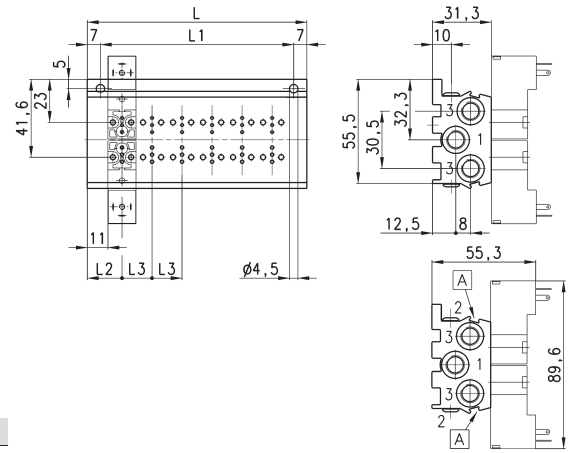

DIMENSIONS							
Mod.	Positions	L	L1	L2	L3	1 (P)	3 (R)
P204-0*	4	53	39	18.5	16	G1/8	G1/8
P206-0*	6	69	55	18.5	16	G1/8	G1/8
P208-0*	8	85	71	18.5	16	G1/8	G1/8
P210-0*	10	101	87	18.5	16	G1/8	G1/8
P212-0*	12	117	103	18.5	16	G1/8	G1/8

* add
- MANIFOLD PORTS
(see CODING EXAMPLE)

A = groove for identification label

Position valve cap



Supplied with:
1x position valve cap
1x interface seal
2x screws

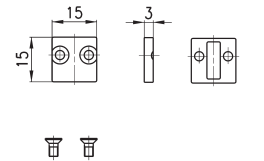

Mod.	P000-TP
------	---------

Connector Mod. 125-... - industrial std. 9.4 mm

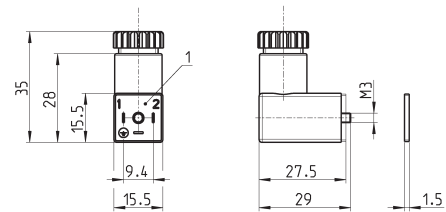

Mod.	description	colour	working voltage	cable gland	tightening torque
125-601	connector, diode + Led	transparent	10/50 V DC	PG7	0.3 Nm
125-701	connector, varistor + Led	transparent	24 V AC/DC	PG7	0.3 Nm
125-800	connector, without electronics	black	-	PG7	0.3 Nm

1 = 90° adjustable connector

Connector Mod. 125-... - industrial std. 9.4 mm - 90° cable



The internal rectifier circuit of the connector Mod. 125-900 allows to use solenoid valves with different AC voltage, even if the voltage indicated on the solenoid valve is DC.

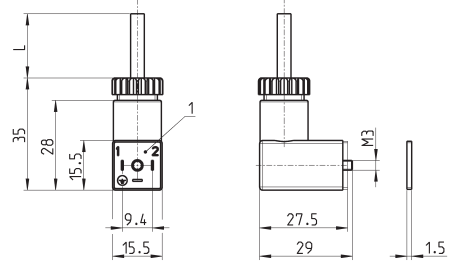

Mod.	description	colour	working voltage	cable length [L]	cable gland	tightening torque
125-501-2	moulded cable with diode + Led	black	10/50 V DC	2000 mm	-	0.3 Nm
125-550-1	moulded cable, without electronics	black	-	1000 mm	-	0.3 Nm
125-601-2	pre-wired cable, diode + Led	transparent	10/50 V DC	2000 mm	PG7	0.3 Nm
125-571-3	moulded cable, varistor + Led	black	24 V AC/DC	3000 mm	-	0.3 Nm
125-900	pre-wired cable with voltage rectifier	black	6 V - 110 V AC/DC	2000 mm	PG7	0.3 Nm

1 = 90° adjustable connector

Connector Mod. 125-... - industrial std. 9.4 mm - in-line cable

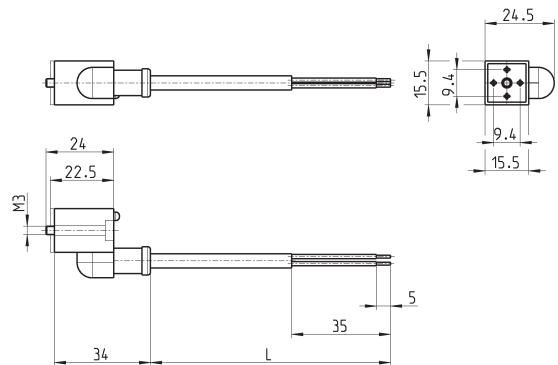

Mod.	description	colour	working voltage	cable length [L]	cable gland	tightening torque
125-503-2	in-line moulded cable, with diode + Led	black	24 V DC	2000 mm	-	0.3 Nm
125-503-5	in-line moulded cable, with diode + Led	black	24 V DC	5000 mm	-	0.3 Nm
125-553-2	in-line moulded cable, without electronics	black	-	2000 mm	-	0.3 Nm
125-553-5	in-line moulded cable, without electronics	black	-	5000 mm	-	0.3 Nm

Conn. Mod. 125-... - ind. std. 9.4 mm - in-line cable+rectifier

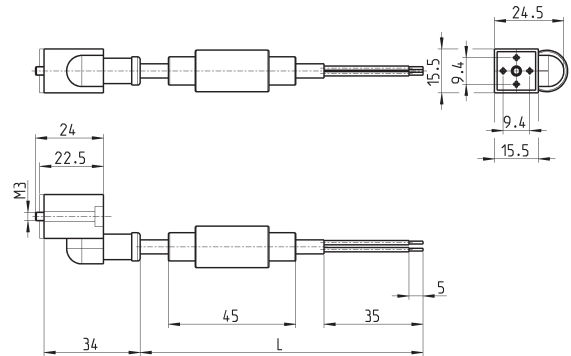

SERIES P SOLENOID VALVES

Mod.	description	colour	working voltage	cable length [L]	cable gland	tightening torque
125-903-2	in-line moulded cable with voltage rectifier	black	6 V - 230 V AC/DC	2000 mm	-	0.3 Nm
125-903-5	in-line moulded cable with voltage rectifier	black	6 V - 230 V AC/DC	5000 mm	-	0.3 Nm

SERIES P MANIFOLD VERSION

Plug-In system based on Series P solenoid valves
 Valve functions: 3/2 NC
 Feasible versions: 8, 10 positions
 Valve width: 15mm
 Multipole electrical connection
 Flexible assembly
 Easy installation

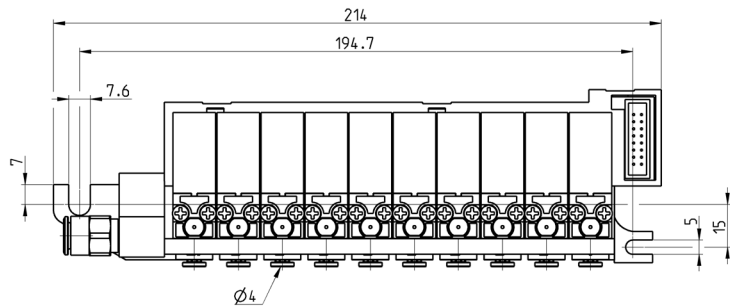
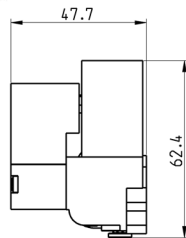
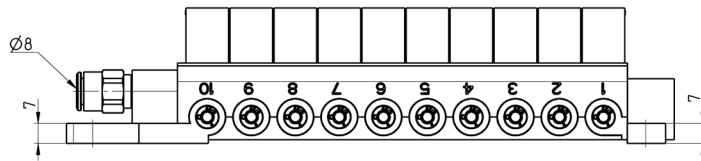
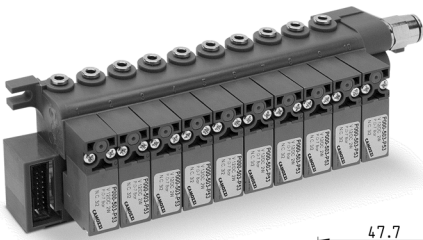
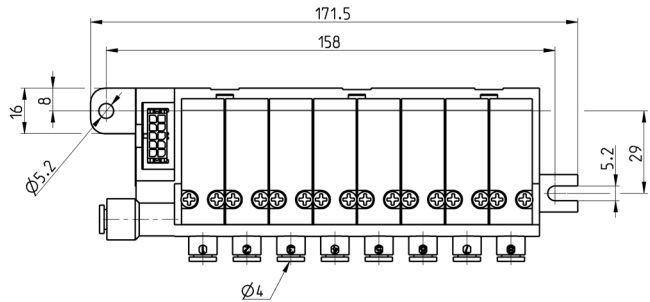
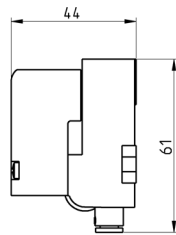
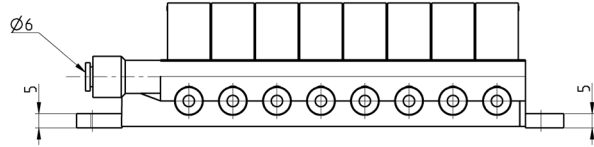
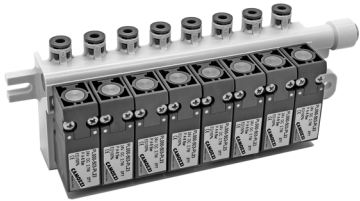

Pneumatic connections	tube* collect inlet and exhaust \varnothing 8 mm - outlets \varnothing 4 mm
Nominal diameter	1.5 mm
Nominal flow	35 NI/min (single solenoid valve)
Operating pressure	0 ÷ 7 bar
Operating temperature	0 ÷ +50°C
Medium	filtered air, class 5.4.4 according to ISO 8573-1 (max oil viscosity 32 cSt), inert gas

* it is recommended to use tube Mod. TPC 4/2 (PU 98°Sh).
 For further information see Camozzi catalogue, section 4.4.15.

Seals	FKM, NBR (FKM on demand)
--------------	--------------------------

Voltage	24 V DC
Voltage tolerance	±10%
Power consumption	2 W
Duty cycle	ED 100%
Electrical connection	Multipole

Series PL directly operated solenoid valves

2/2-way - Normally Open (NO)

3/2-way - Normally Closed (NC) and Normally Open (NO)

3/2-way - Universal (UNI)



- » Application sectors:
 - Industrial Automation
 - Life Science
 - Transportation
- » Can be mounted on a single base (M5 connections) or on manifold (M5 connections or cartridge Ø3 and Ø4)

Please note that all Series PL solenoid valves are supplied with direct current (DC). To operate in alternating current (AC), it is necessary to use the connector with bridge rectifier Mod. 125-900.

Series PL directly operated mini-solenoid valves are available in the NO version and can be mounted on single bases or on manifolds.

GENERAL DATA

TECHNICAL FEATURES

Function	2/2 NO - 3/2 NC - 3/2 NO - 3/2 UNI
Operation	direct acting poppet type
Pneumatic connections	on subbase
Orifice diameter	0.8 ... 1.6 mm
Flow coefficient kv (l/min)	0.30 ... 0.62
Operating pressure	0 ÷ 3.5 ... 10 bar
Operating temperature	0 ÷ 50 °C (FKM) / -50 ÷ 50 °C (low temperature NBR on demand)
Media	filtered air, class 5.4.4 according to ISO 8573-1 (max oil viscosity 32 cSt), inert gas
Response time	ON <10 ms - OFF <15 ms
Manual override	mono/bistable - PBT 3/2 versions only
Installation	in any position

MATERIALS IN CONTACT WITH THE MEDIUM

Body	brass - PBT - PPS
Seals	FKM - NBR - EPDM (on demand)
Internal parts	brass - stainless steel

ELECTRICAL FEATURES

Voltage	6 ... 110 V DC - other voltages on demand
Voltage tolerance	±10%
Power consumption	1.2 ... 2.7 W
Duty cycle	ED 100%
Electrical connection	industrial standard connector (9.4 mm)
Protection class	IP65 with connector

Special versions available on demand

CODING EXAMPLE

PL	0	00	-	3	0	3	-	PL	2	3	
-----------	----------	-----------	----------	----------	----------	----------	----------	-----------	----------	----------	--

PL	SERIES
0	<p>BODY DESIGN</p> <p>0 = single sub-base (M5 only) or interface 1 = manifold - valves single side 2 = manifold - valves double side</p>
00	<p>NUMBER OF POSITIONS</p> <p>00 = ISO 15218 or Series PD interface 01 = single base (M5 only) 02 ÷ 99 = manifold number of positions</p>
3	<p>NUMBER OF WAYS - FUNCTIONS</p> <p>0 = manifolds or single base 9 = 2/2-way - NO A = 2/2-way - NO electric part revolved by 180° 3 = 3/2-way - NC 5 = 3/2-way - NC electric part revolved by 180° 4 = 3/2-way - NO 6 = 3/2-way - NO electric part revolved by 180° B = 3/2-way - NO IN-LINE* C = 3/2-way - NO IN-LINE* electric part revolved by 180° 7 = 3/2-way - UNI 8 = 3/2-way - UNI electric part revolved by 180°</p>
0	<p>VALVE PORTS</p> <p>0 = ISO 15218 interface - 3/2-way B = series PD interface - 2/2-way</p> <p>MANIFOLD PORTS for P - PL - PN - W Series</p> <p>2 = M5 thread - front outlets 3 = tube Ø 3 mm fittings - front outlets 4 = tube Ø 4 mm fittings - front outlets 6 = M5 thread - front outlets 7 = tube Ø 3 mm fittings - bottom outlets 8 = tube Ø 4 mm fittings - bottom outlets</p>
3	<p>ORIFICE DIAMETER</p> <p>B = Ø 0.8 mm 1 = Ø 1.1 mm 3 = Ø 1.5 mm (NC version with pressure 4 ÷ 8 bar only) 5 = Ø 1.5 mm 6 = Ø 1.5 mm (NC version with pressure 0 ÷ 3.5 bar only) 7 = Ø 1.6 mm</p>
PL	<p>MATERIALS</p> <p>PL = PBT body - FKM poppet seal - NBR other seals PF = PBT body - FKM seals SF = PPS body - FKM seals ST = PPS body - Low Temperature NBR seals (on demand) BF = nickel-planted brass body - FKM seals</p>
2	<p>ELECTRICAL CONNECTION</p> <p>2 = industrial standard connection (9.4 mm)</p>
3	<p>VOLTAGE - POWER CONSUMPTION</p> <p>1 = 6 V DC - 2.7 W - PBT 2 = 12 V DC - 2.7 W - PBT 3 = 24 V DC - 2.7 W - PBT A = 6 V DC - 2.2 W - PPS B = 12 V DC - 2.2 W - PPS C = 24 V DC - 2.2 W - PPS H = 110 V DC - 3 W - PPS</p>
	<p>FIXING</p> <p>= fixing screws for metal P = fixing screws for plastics</p>
	<p>MANUAL OVERRIDE</p> <p>= not required or not applicable T = mono/bistable (push/turn type)</p>
	<p>OPTIONS</p> <p>= standard OX1 = for use with oxygen (non volatile residual less than 550 mg/m²)</p>

* 3/2 NO IN LINE version: port position 1 - 2 - 3 are identical to port positions of 3/2 NC versions

Series PL solenoid valve - 2/2-way NO - series PD interface



Supplied with:
 2x O-Rings
 2x M3x20 screws for mounting on metal
 or
 2x Ø3x23 screws for mounting on plastic
 (opt. P)

* add
 - VOLTAGE
 - FIXING
 (see CODING EXAMPLE)

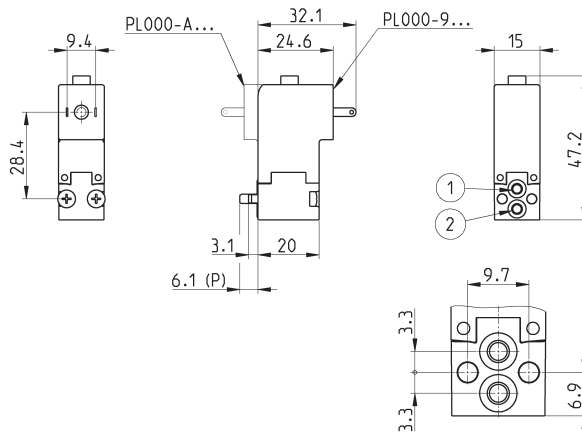
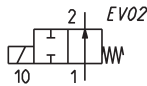

Mod.	Function	Orifice Ø (mm)	kv (l/min)	Min+max pressure (bar)	Body material	Seals material	Manual override	Power (W)
PL000-9B7-PF2*	2/2 NO	1.6	0.62	0 ÷ 6.5	PBT	FKM	no	2.7
PL000-9B7-BF2*	2/2 NO	1.6	0.62	0 ÷ 6.5	brass	FKM	no	2.7

Series PL solenoid valve - 3/2-way NC



Supplied with:
 1x interface seal
 2x M3x20 screws for mounting on metal
 or
 2x Ø3x23 screws for mounting on plastic
 (opt. P)

Also available ST models for
 T amb. -50 ÷ 50 °C with NBR seals.

* add
 - VOLTAGE
 - FIXING
 (see CODING EXAMPLE)

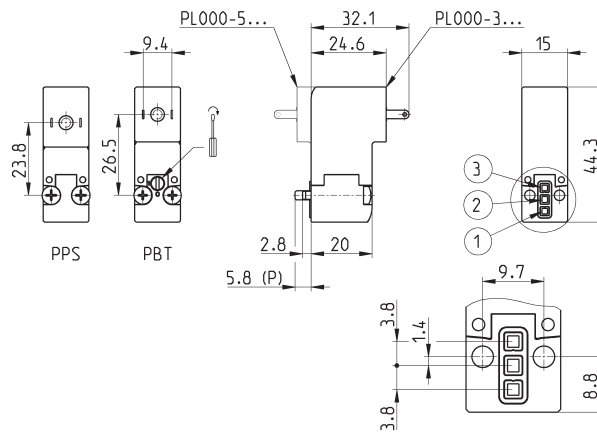
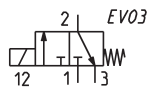

Mod.	Function	Orifice Ø (mm)	kv (l/min)	Min+max pressure (bar)	Body material	Seals material	Manual override	Power (W)
PL000-30B-PF2*	3/2 NC	0.8	0.30	0 ÷ 10	PBT	FKM	no	1.2
PL000-30B-PF2*T	3/2 NC	0.8	0.30	0 ÷ 10	PBT	FKM	mono/bistable	1.2
PL000-30B-SF2*	3/2 NC	0.8	0.30	0 ÷ 10	PPS	FKM	no	1.2
PL000-301-PF2*	3/2 NC	1.1	0.34	0 ÷ 7	PBT	FKM	no	2.7
PL000-301-PF2*T	3/2 NC	1.1	0.34	0 ÷ 7	PBT	FKM	mono/bistable	2.7
PL000-301-SF2*	3/2 NC	1.1	0.34	0 ÷ 8	PPS	FKM	no	2.2
PL000-303-PL2*	3/2 NC	1.5	0.47	4 ÷ 8	PBT	FKM+NBR	no	2.7
PL000-303-PF2*T	3/2 NC	1.5	0.47	4 ÷ 8	PBT	FKM	mono/bistable	2.7
PL000-306-PL2*	3/2 NC	1.5	0.47	0 ÷ 3.5	PBT	FKM+NBR	no	2.7
PL000-306-PF2*T	3/2 NC	1.5	0.47	0 ÷ 3.5	PBT	FKM	mono/bistable	2.7

Series PL solenoid valve - 3/2-way NO



Supplied with:
1x interface seal
2x M3x20 screws for mounting on metal
or
2x Ø3x23 screws for mounting on plastic
(opt. P)

Also available ST models for
T amb. -50 ÷ 50 °C with NBR seals.

* add
- VOLTAGE
- FIXING
(see CODING EXAMPLE)

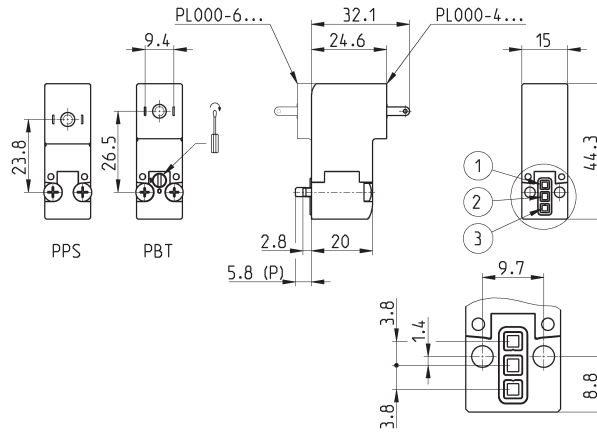
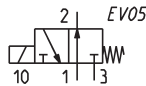

Mod.	Function	Orifice Ø (mm)	kv (l/min)	Min+max pressure (bar)	Body material	Seals material	Manual override	Power (W)
PL000-40B-PF2*	3/2 NO	0.8	0.30	0 ÷ 10	PBT	FKM	no	2.7
PL000-40B-PF2*T	3/2 NO	0.8	0.30	0 ÷ 10	PBT	FKM	mono/bistable	2.7
PL000-40B-SF2*	3/2 NO	0.8	0.30	0 ÷ 10	PPS	FKM	no	2.2
PL000-401-PF2*	3/2 NO	1.1	0.34	0 ÷ 7	PBT	FKM	no	2.7
PL000-401-PF2*T	3/2 NO	1.1	0.34	0 ÷ 7	PBT	FKM	mono/bistable	2.7
PL000-401-SF2*	3/2 NO	1.1	0.34	0 ÷ 7	PPS	FKM	no	2.2
PL000-405-PF2*	3/2 NO	1.5	0.42	0 ÷ 6.5	PBT	FKM	no	2.7
PL000-405-PF2*T	3/2 NO	1.5	0.42	0 ÷ 6.5	PBT	FKM	mono/bistable	2.7
PL000-405-SF2*	3/2 NO	1.5	0.42	0 ÷ 6.5	PPS	FKM	no	2.2

Series PL solenoid valve - 3/2-way NO IN-LINE



Supplied with:
1x interface seal
2x M3x20 screws for mounting on metal
or
2x Ø3x23 screws for mounting on plastic
(opt. P)

Also available ST models for
T amb. -50 ÷ 50 °C with NBR seals.

* add
- VOLTAGE
- FIXING
(see CODING EXAMPLE)

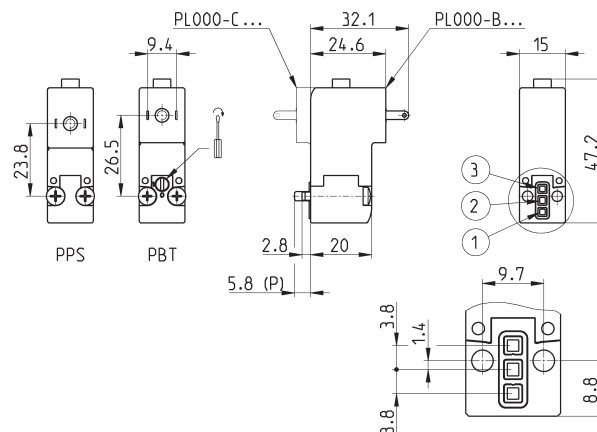
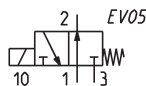

Mod.	Function	Orifice Ø (mm)	kv (l/min)	Min+max pressure (bar)	Body material	Seals material	Manual override	Power (W)
PL000-B01-PF2*	3/2 NO IN-LINE	1.1	0.34	0 ÷ 7	PBT	FKM	no	2.7
PL000-B01-SF2*	3/2 NO IN-LINE	1.1	0.34	0 ÷ 7	PPS	FKM	no	2.2

Series PL solenoid valve - 3/2-way UNI



Supplied with:
 1x interface seal
 2x M3x20 screws for mounting on metal
 or
 2x Ø3x23 screws for mounting on plastic
 (opt. P)

Also available models for T amb.
 -50 ÷ 50 °C with NBR seals

Vacuum operation with max. pressure
 reduction

* add
 - VOLTAGE
 - FIXING
 (see CODING EXAMPLE)

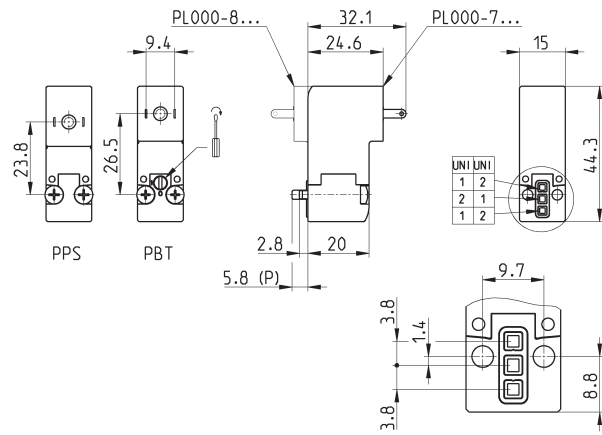
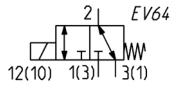

Mod.	Function	Orifice Ø (mm)	kv (l/min)	Min÷max pressure (bar)	Body material	Seals material	Manual override	Power (W)
PL000-705-PF2*	3/2 UNI	1.5	0.42	0 ÷ 3.5 [-1 ÷ 2.5]	PBT	FKM	no	2.7
PL000-705-PF2*T	3/2 UNI	1.5	0.42	0 ÷ 3.5 [-1 ÷ 2.5]	PBT	FKM	mono/bistable	2.7
PL000-705-SF2*	3/2 UNI	1.5	0.42	0 ÷ 3.5 [-1 ÷ 2.5]	PPS	FKM	no	2.2

Single sub-base for 15mm size 2 way interface



Single sub-base suitable for 2-way solenoid valves Series PD and PL models PD000-2A..., PL000-9B...
Use solenoid valves with fixing screws for metal (see codification page)

Material: anodized aluminium
Connections: G1/8 threads

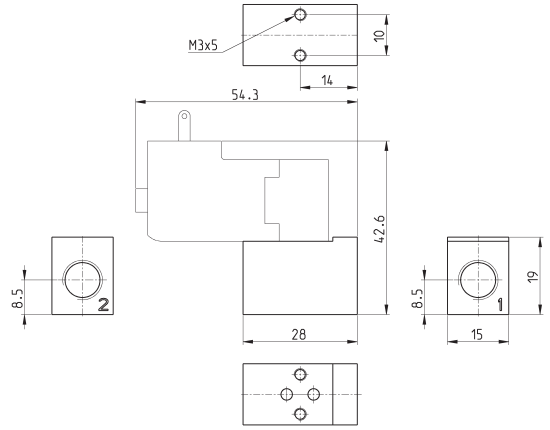

Mod.
PDA01-1/8

Single sub-base for 3-way solenoid valve size 15 mm



Single sub-base suitable for Series P - PL - PN - W 3-way solenoid valve
Use solenoid valves with screws for mounting on metal (see coding)

Material: anodized aluminium
Connections: M5 threads

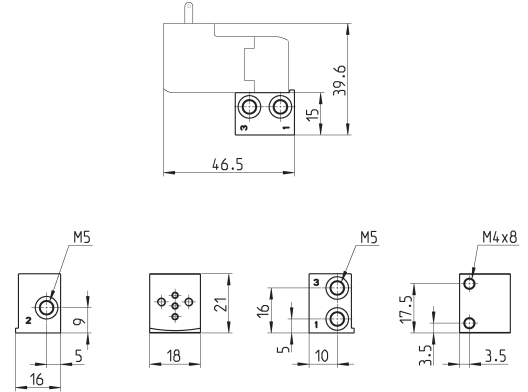

Mod.
P001-02

Single manifold with rear outlets



Manifold suitable for Series P - PL - PN - W 3-way solenoid valve
Use solenoid valves with screws for mounting on metal (see coding)

Material: anodized aluminium

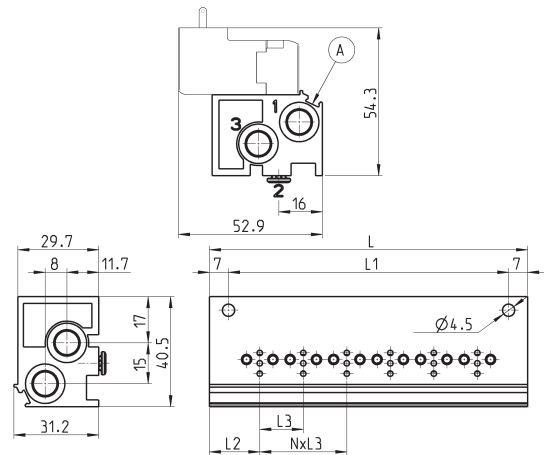

DIMENSIONS							
Mod.	Positions	L	L1	L2	L3	1 (P)	3 (R)
P102-0*	2	53	39	18,5	16	G1/8	G1/8
P103-0*	3	69	55	18,5	16	G1/8	G1/8
P104-0*	4	85	71	18,5	16	G1/8	G1/8
P105-0*	5	101	87	18,5	16	G1/8	G1/8
P106-0*	6	117	103	18,5	16	G1/8	G1/8

* add
- MANIFOLD PORTS
(see CODING EXAMPLE)

A = groove for identification label

Manifold - single side valve - frontal outlets



Manifold suitable for Series P - PL - PN - W
3-way solenoid valve
Use solenoid valves with screws for mounting on metal (see coding)

Can be fixed through DIN 46277/3 guide with the accessory PCF-E520.

Material: anodized aluminium

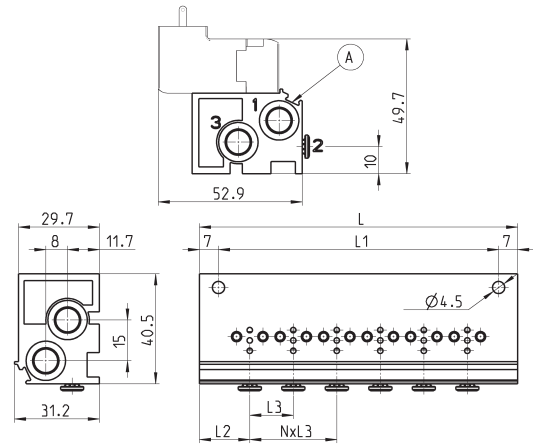

DIMENSIONS							
Mod.	Positions	L	L1	L2	L3	1 (P)	3 (R)
P102-0*	2	53	39	18,5	16	G1/8	G1/8
P103-0*	3	69	55	18,5	16	G1/8	G1/8
P104-0*	4	85	71	18,5	16	G1/8	G1/8
P105-0*	5	101	87	18,5	16	G1/8	G1/8
P106-0*	6	117	103	18,5	16	G1/8	G1/8

* add
- MANIFOLD PORTS
(see CODING EXAMPLE)

A = groove for identification label

Manifold - double side valve - bottom outlets



Manifold suitable for Series P - PL - PN - W
3-way solenoid valve
Use solenoid valves with screws for mounting on metal (see coding)

Material: anodized aluminium

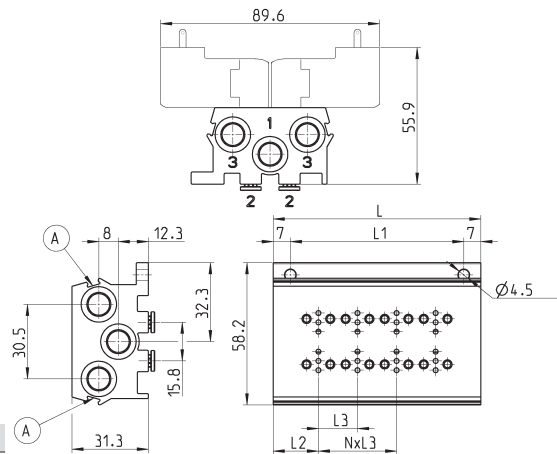

DIMENSIONS							
Mod.	Positions	L	L1	L2	L3	1 (P)	3 (R)
P204-0*	4	53	39	18,5	16	G1/8	G1/8
P206-0*	6	69	55	18,5	16	G1/8	G1/8
P208-0*	8	85	71	18,5	16	G1/8	G1/8
P210-0*	10	101	87	18,5	16	G1/8	G1/8
P212-0*	12	117	103	18,5	16	G1/8	G1/8

* add
- MANIFOLD PORTS
(see CODING EXAMPLE)

A = groove for identification label

Manifold - double side valve - frontal outlets



Manifold suitable for Series P - PL - PN - W
3-way solenoid valve
Use solenoid valves with screws for mounting on metal (see coding)

Can be fixed through DIN 46277/3 guide with the accessory PCF-E520.

Material: anodized aluminium

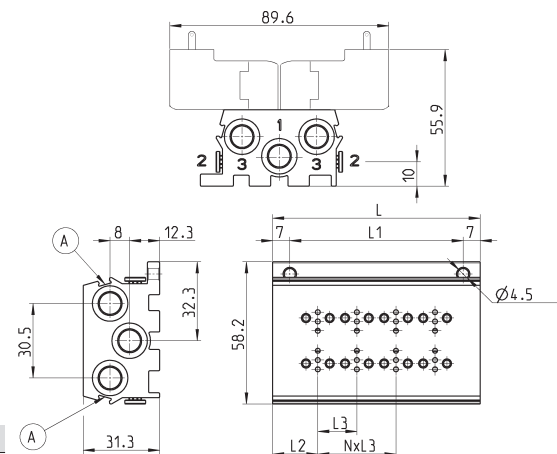

DIMENSIONS							
Mod.	Positions	L	L1	L2	L3	1 (P)	3 (R)
P204-0*	4	53	39	18,5	16	G1/8	G1/8
P206-0*	6	69	55	18,5	16	G1/8	G1/8
P208-0*	8	85	71	18,5	16	G1/8	G1/8
P210-0*	10	101	87	18,5	16	G1/8	G1/8
P212-0*	12	117	103	18,5	16	G1/8	G1/8

* add
- MANIFOLD PORTS
(see CODING EXAMPLE)

A = groove for identification label

Position valve cap



Supplied with:
1x position valve cap
1x interface seal
2x screws

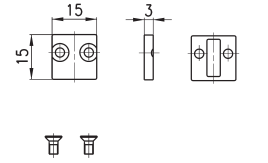

Mod.	P000-TP
------	---------

Connector Mod. 125-... - industrial std. 9.4 mm

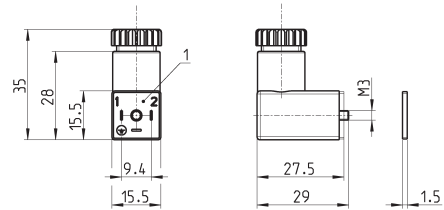

Mod.	description	colour	working voltage	cable gland	tightening torque
125-601	connector, diode + Led	transparent	10/50 V DC	PG7	0.3 Nm
125-701	connector, varistor + Led	transparent	24 V AC/DC	PG7	0.3 Nm
125-800	connector, without electronics	black	-	PG7	0.3 Nm

1 = 90° adjustable connector

Connector Mod. 125-... - industrial std. 9.4 mm - 90° cable



The internal rectifier circuit of the connector Mod. 125-900 allows to use solenoid valves with different AC voltage, even if the voltage indicated on the solenoid valve is DC.

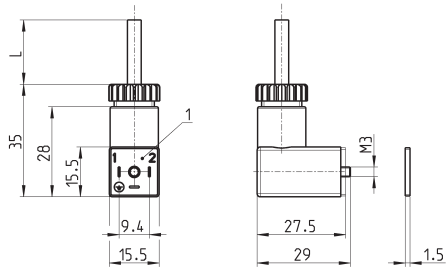

Mod.	description	colour	working voltage	cable length [L]	cable gland	tightening torque
125-501-2	moulded cable with diode + Led	black	10/50 V DC	2000 mm	-	0.3 Nm
125-550-1	moulded cable, without electronics	black	-	1000 mm	-	0.3 Nm
125-601-2	pre-wired cable, diode + Led	transparent	10/50 V DC	2000 mm	PG7	0.3 Nm
125-571-3	moulded cable, varistor + Led	black	24 V AC/DC	3000 mm	-	0.3 Nm
125-900	pre-wired cable with voltage rectifier	black	6 V - 110 V AC/DC	2000 mm	PG7	0.3 Nm

1 = 90° adjustable connector

Connector Mod. 125-... - industrial std. 9.4 mm - in-line cable

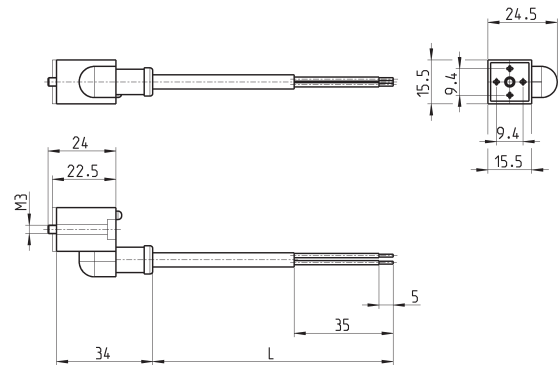

Mod.	description	colour	working voltage	cable length [L]	cable gland	tightening torque
125-503-2	in-line moulded cable, with diode + Led	black	24 V DC	2000 mm	-	0.3 Nm
125-503-5	in-line moulded cable, with diode + Led	black	24 V DC	5000 mm	-	0.3 Nm
125-553-2	in-line moulded cable, without electronics	black	-	2000 mm	-	0.3 Nm
125-553-5	in-line moulded cable, without electronics	black	-	5000 mm	-	0.3 Nm

Conn. Mod. 125-... - ind. std. 9.4 mm - in-line cable+rectifier

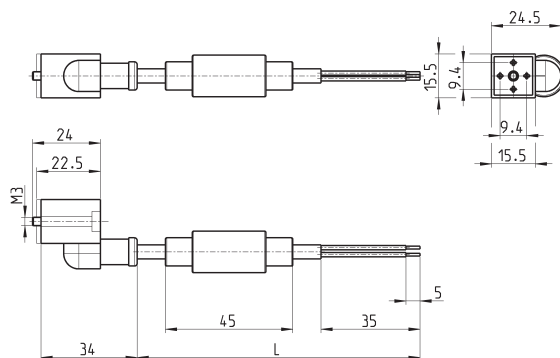

Mod.	description	colour	working voltage	cable length [L]	cable gland	tightening torque
125-903-2	in-line moulded cable with voltage rectifier	black	6 V - 230 V AC/DC	2000 mm	-	0.3 Nm
125-903-5	in-line moulded cable with voltage rectifier	black	6 V - 230 V AC/DC	5000 mm	-	0.3 Nm

Series PN directly operated solenoid valves

3/2-way - Normally Closed (NC)



- » Can be mounted on a single base (M5 connections) or on manifold (M5 connections or fittings for Ø3 or Ø4 tube)
- » Compact design suitable for use in reduced mounting space

Please note that all Series PN solenoid valves are supplied with direct current (DC). To operate in alternating current (AC), it is necessary to use the connector with bridge rectifier Mod. 125-900.

Series PN directly operated solenoid valves are available as 3/2-way NC.

GENERAL DATA

TECHNICAL FEATURES

Function	3/2 NC
Operation	direct acting poppet type
Pneumatic connections	on subbase with ISO 12238 interface
Orifice diameter	0.8 mm
Flow coefficient kv (l/min)	0.19
Operating pressure	0 ÷ 10 bar
Operating temperature	0 ÷ 50 °C
Media	filtered air, class 5.4.4 according to ISO 8573-1 (max oil viscosity 32 cSt), inert gas
Response time (ISO 12238)	ON <10 ms - OFF <15 ms
Installation	in any position

MATERIALS IN CONTACT WITH THE MEDIUM

Body	PBT
Seals	FKM - NBR
Internal parts	stainless steel

ELECTRICAL FEATURES

Voltage	24 ... 205 V DC - other voltages on demand
Voltage tolerance	±10%
Power consumption	1 ... 2 W
Duty cycle	ED 100%
Electrical connection	industrial standard connector (9.4 mm)
Protection class	IP65 with connector

Special versions available on demand

CODING EXAMPLE

PN	0	00	-	3	0	1	-	P	5	3	
-----------	----------	-----------	----------	----------	----------	----------	----------	----------	----------	----------	--

PN	SERIES
0	<p>BODY DESIGN 0 = single sub-base 1 = single manifold 2 = double sided manifold</p>
00	<p>NUMBER OF POSITIONS 00 = ISO 15218 interface 01 = single base (M5 only) 02 = 99 = manifold number of positions</p>
3	<p>NUMBER OF WAYS - FUNCTIONS 0 = manifold or single base 3 = 3/2-way - NC</p>
0	<p>VALVE PORTS 0 = ISO 15218 interface</p> <p>MANIFOLD PORTS for P - PL - PN - W Series 2 = M5 thread - front outlets 3 = tube Ø 3 mm fittings - front outlets 4 = tube Ø 4 mm fittings - front outlets 6 = M5 thread - bottom outlets 7 = tube Ø 3 mm fittings - bottom outlets 8 = tube Ø 4 mm fittings - bottom outlets</p>
1	<p>ORIFICE DIAMETER 1 = Ø 0.8 mm</p>
P	<p>MATERIALS P = PBT body - seals FKM - NBR</p>
5	<p>ELECTRICAL CONNECTION 5 = industrial standard (9.4 mm)</p>
3	<p>VOLTAGE - POWER CONSUMPTION 3 = 24 V DC - 1 W 4 = 48 V DC - 2 W 6 = 110 V DC - 2 W 7 = 205 V DC - 1.7 W</p>
	<p>FIXING = fixing screws for plastic P = fixing screws for metal</p>

Series PN solenoid valve - 3/2-way NC



Supplied with:
1x interface seal
2x Ø3x25 screws for mounting on plastic
or
2x M3x22 screws for mounting on metal

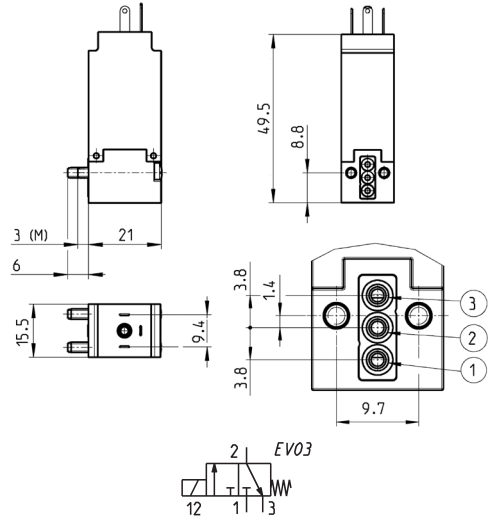

Mod.	Function	Orifice Ø (mm)	kv (l/m)	Min-max pressure (bar)	Voltage Power
PN000-301-P53*	3/2 NC	0.8	0.19	0 ÷ 10	24 V DC 1 W
PN000-301-P54*	3/2 NC	0.8	0.19	0 ÷ 10	48 V DC 2 W
PN000-301-P56*	3/2 NC	0.8	0.19	0 ÷ 10	110 V DC 2 W
PN000-301-P57*	3/2 NC	0.8	0.19	0 ÷ 10	205 V DC 1.7 W

* add
- FIXING
(see CODING EXAMPLE)

Single sub-base for 3-way solenoid valve size 15 mm



Single sub-base suitable for Series P - PL - PN - W
3-way solenoid valve
Use solenoid valves with screws for mounting on metal (see coding)

Material: anodized aluminium
Connections: M5 threads

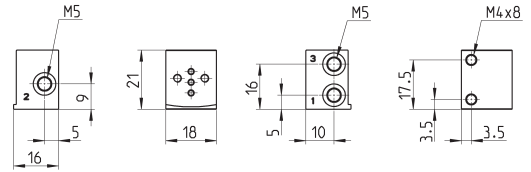
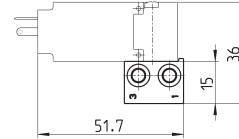

Mod.
P001-02

Manifold - single side valve - bottom outlets



Manifold suitable for Series P - PL - PN - W
3-way solenoid valve
Use solenoid valves with screws for mounting on metal (see coding)

Material: anodized aluminium

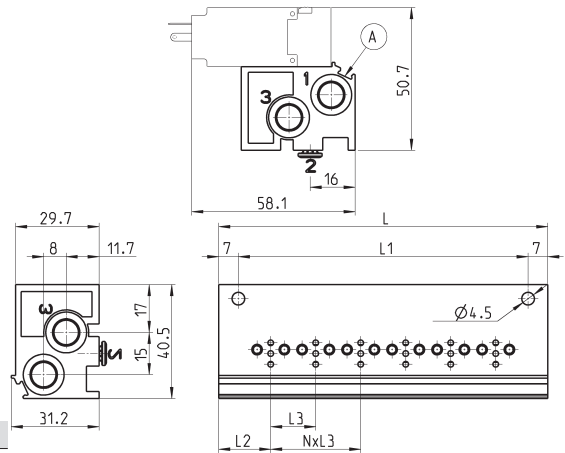

DIMENSIONS							
Mod.	Positions	L	L1	L2	L3	1 (P)	3 (R)
P102-0*	2	53	39	18,5	16	G1/8	G1/8
P103-0*	3	69	55	18,5	16	G1/8	G1/8
P104-0*	4	85	71	18,5	16	G1/8	G1/8
P105-0*	5	101	87	18,5	16	G1/8	G1/8
P106-0*	6	117	103	18,5	16	G1/8	G1/8

* add
- MANIFOLD PORTS
(see CODING EXAMPLE)

A= groove for identification label

Manifold - single side valve - frontal outlets



Manifold suitable for Series P - PL - PN - W
3-way solenoid valve
Use solenoid valves with screws for mounting on metal (see coding)

Can be fixed through DIN 46277/3 guide with the accessory PCF-E520.

Material: anodized aluminium

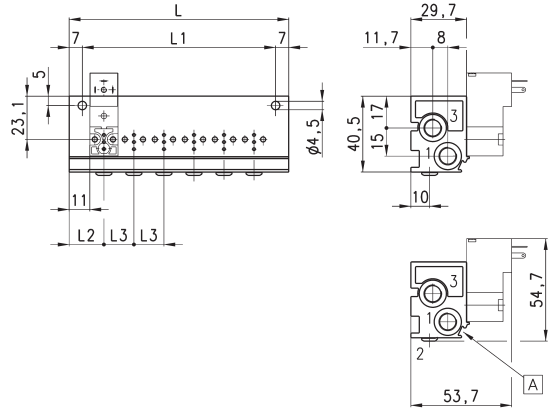

DIMENSIONS							
Mod.	Positions	L	L1	L2	L3	1 (P)	3 (R)
P102-0*	2	53	39	18,5	16	G1/8	G1/8
P103-0*	3	69	55	18,5	16	G1/8	G1/8
P104-0*	4	85	71	18,5	16	G1/8	G1/8
P105-0*	5	101	87	18,5	16	G1/8	G1/8
P106-0*	6	117	103	18,5	16	G1/8	G1/8

* add
- MANIFOLD PORTS
(see CODING EXAMPLE)

A= groove for identification label

Manifold - double side valve - bottom outlets



Manifold suitable for Series P - PL - PN - W
3-way solenoid valve
Use solenoid valves with screws for mounting on metal (see coding)

Material: anodized aluminium

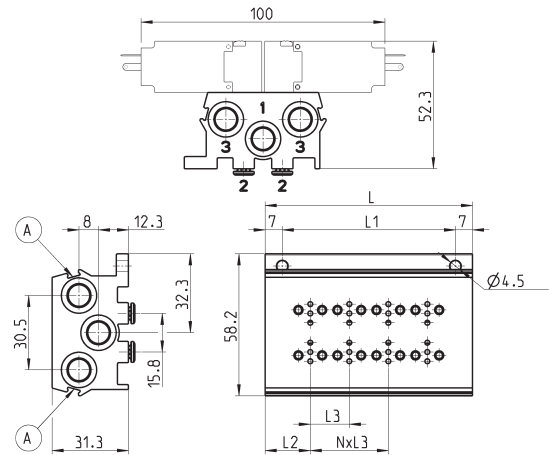

DIMENSIONS							
Mod.	Positions	L	L1	L2	L3	1 (P)	3 (R)
P204-0*	4	53	39	18,5	16	G1/8	G1/8
P206-0*	6	69	55	18,5	16	G1/8	G1/8
P208-0*	8	85	71	18,5	16	G1/8	G1/8
P210-0*	10	101	87	18,5	16	G1/8	G1/8
P212-0*	12	117	103	18,5	16	G1/8	G1/8

* add
- MANIFOLD PORTS
(see CODING EXAMPLE)

A= groove for identification label

Manifold - double side valve - frontal outlets



Manifold suitable for Series P - PL - PN - W
3-way solenoid valve
Use solenoid valves with screws for mounting on metal (see coding)

Can be fixed through DIN 46277/3 guide with the accessory PCF-E520.

Material: anodized aluminium

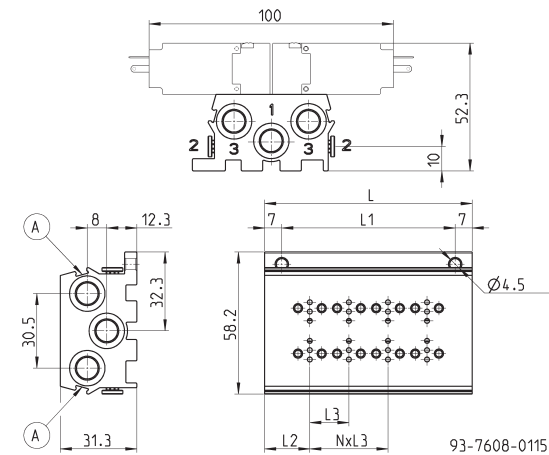

DIMENSIONS							
Mod.	Positions	L	L1	L2	L3	1 (P)	3 (R)
P204-0*	4	53	39	18,5	16	G1/8	G1/8
P206-0*	6	69	55	18,5	16	G1/8	G1/8
P208-0*	8	85	71	18,5	16	G1/8	G1/8
P210-0*	10	101	87	18,5	16	G1/8	G1/8
P212-0*	12	117	103	18,5	16	G1/8	G1/8

* add
- MANIFOLD PORTS
(see CODING EXAMPLE)

A= groove for identification label

93-7608-0115

Position valve cap



Supplied with:
1x position valve cap
1x interface seal
2x screws

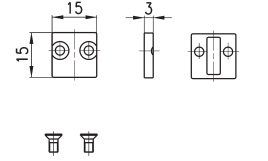

Mod.	P000-TP
------	---------

Connector Mod. 125-... - industrial std. 9.4 mm

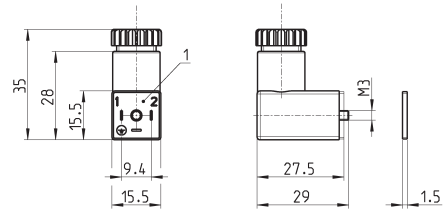

Mod.	description	colour	working voltage	cable gland	tightening torque
125-601	connector, diode + Led	transparent	10/50 V DC	PG7	0.3 Nm
125-701	connector, varistor + Led	transparent	24 V AC/DC	PG7	0.3 Nm
125-800	connector, without electronics	black	-	PG7	0.3 Nm

1 = 90° adjustable connector

Connector Mod. 125-... - industrial std. 9.4 mm - 90° cable



The internal rectifier circuit of the connector Mod. 125-900 allows to use solenoid valves with different AC voltage, even if the voltage indicated on the solenoid valve is DC.

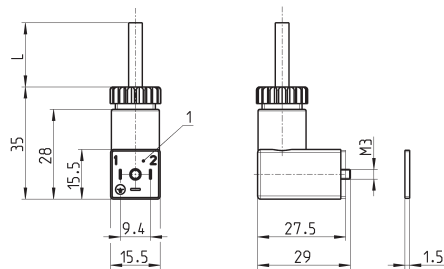

Mod.	description	colour	working voltage	cable length [L]	cable gland	tightening torque
125-501-2	moulded cable with diode + Led	black	10/50 V DC	2000 mm	-	0.3 Nm
125-550-1	moulded cable, without electronics	black	-	1000 mm	-	0.3 Nm
125-601-2	pre-wired cable, diode + Led	transparent	10/50 V DC	2000 mm	PG7	0.3 Nm
125-571-3	moulded cable, varistor + Led	black	24 V AC/DC	3000 mm	-	0.3 Nm
125-900	pre-wired cable with voltage rectifier	black	6 V - 110 V AC/DC	2000 mm	PG7	0.3 Nm

1 = 90° adjustable connector

Connector Mod. 125-... - industrial std. 9.4 mm - in-line cable

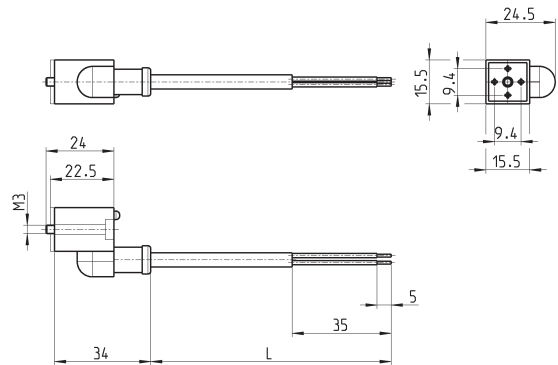

Mod.	description	colour	working voltage	cable length [L]	cable gland	tightening torque
125-503-2	in-line moulded cable, with diode + Led	black	24 V DC	2000 mm	-	0.3 Nm
125-503-5	in-line moulded cable, with diode + Led	black	24 V DC	5000 mm	-	0.3 Nm
125-553-2	in-line moulded cable, without electronics	black	-	2000 mm	-	0.3 Nm
125-553-5	in-line moulded cable, without electronics	black	-	5000 mm	-	0.3 Nm

Conn. Mod. 125-... - ind. std. 9.4 mm - in-line cable+rectifier

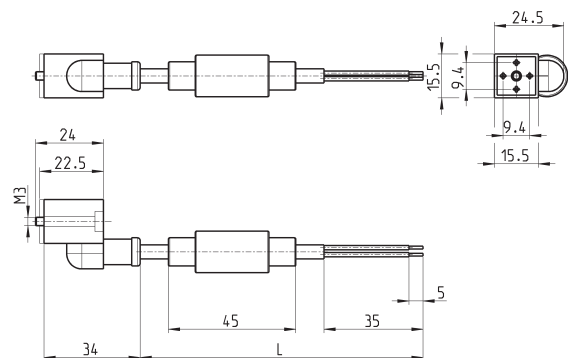

Mod.	description	colour	working voltage	cable length [L]	cable gland	tightening torque
125-903-2	in-line moulded cable with voltage rectifier	black	6 V - 230 V AC/DC	2000 mm	-	0.3 Nm
125-903-5	in-line moulded cable with voltage rectifier	black	6 V - 230 V AC/DC	5000 mm	-	0.3 Nm

Series PD directly operated solenoid valves

2/2-way - Normally Closed (NC)

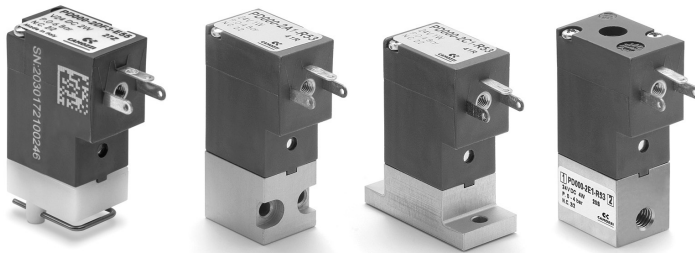

Please note that all Series PD solenoid valves are supplied with direct current (DC). To operate in alternating current (AC), it is necessary to use the connector with bridge rectifier Mod. 125-900.

The Series PD directly operated solenoid valves are available in the 2/2-way normally closed (NC) version. Pneumatic interfaces allow installation on manifolds in horizontal or vertical position. Also available with threaded connections.

GENERAL DATA

TECHNICAL FEATURES

Function	2/2 NC
Operation	direct acting poppet type
Pneumatic connections	on subbase - M5 threads
Orifice diameter	0.8 ... 2.5 mm
Flow coefficient kv (l/min)	0.39 ... 1.93
Operating pressure	-0.9 ÷ 4 ... 12 bar
Operating temperature	0 ÷ 50 °C
Media	filtered air, class 5.4.4 according to ISO 8573-1 (max oil viscosity 32 cSt), inert gas - liquids (on demand)
Response time	<15 ms
Installation	in any position

MATERIALS IN CONTACT WITH THE MEDIUM

Body	brass - anodized aluminium - POM
Seals	NBR - FKM - EPDM
Internal parts	stainless steel

ELECTRICAL FEATURES

Voltage	12 ... 24 V DC - other voltages on demand
Voltage tolerance	1 and 2 W ±10% - 4 W ±5%
Power consumption	1 ... 4 W
Duty cycle	ED 100% (1 and 2 W) - ED 50% (4W) see the ED definition diagram
Electrical connection	industrial standard connector (9.4 mm)
Protection class	IP65 with connector

Special versions available on demand

New models

CODING EXAMPLE

PD	0	00	-	2	A	1	-	R	5	3	
PD	SERIES										
0	BODY DESIGN 0 = single body										
00	NUMBER OF POSITIONS 00 = interface										
2	NUMBER OF WAYS - FUNCTIONS 2 = 2/2-way - NC										
A	MATERIAL - BODY CONNECTIONS A = aluminium body - lateral interface AR = aluminium body - lateral interface - electric part revolved by 180° C = aluminium body - bottom interface CR = aluminium body - bottom interface - electric part revolved by 180° DF = POM body - bottom interface DR = POM body - bottom interface - electric part revolved by 180° E = brass body - M5 threaded ports ER = brass body - M5 threaded ports - electric part revolved by 180°										
1	ORIFICE DIAMETER 1 = Ø 0.8 mm 2 = Ø 1.2 mm 3 = Ø 1.6 mm 4 = Ø 2.0 mm 5 = Ø 2.5 mm										
R	SEAL MATERIAL R = NBR F = FKM E = EPDM										
5	ELECTRICAL CONNECTION 5 = industrial standard (9.4 mm)										
3	VOLTAGE - POWER CONSUMPTION 1 = 12 V DC - 1 W 2 = 12 V DC - 2 W 3 = 24 V DC - 1 W 5 = 24 V DC - 2 W 8 = 24 V DC - 4 W										
	FIXING = with screws for metal P = with screws for plastics										
	OPTIONS = standard OX1 = for use with oxygen (non volatile residual less than 550 mg/m ²) OX2 = for use with oxygen (non volatile residual less than 33 mg/m ²)										

SERIES PD SOLENOID VALVES

ED definition diagram

Operating factor lower than 50%

T1 = cycle time (5 minutes max)

T2 = energizing time

t = time (minutes)

V = working voltage (volt)

ED = T2/T1 x 100

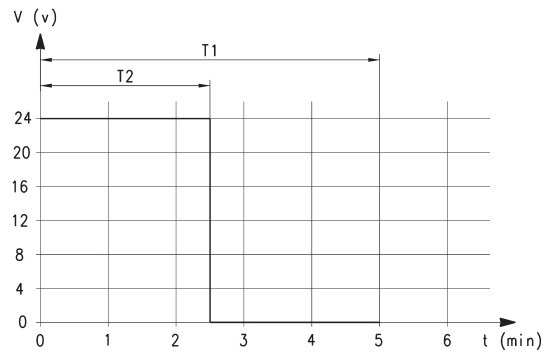

Series PD solenoid valve - aluminium body - lateral interface



Supplied with:
2x O-Rings
2x M3x20 screws for mounting on metal
or
2x Ø3x23 screws for mounting on plastic

For vacuum applications connect the suction source to port 2

* add
- SEAL MATERIAL
- VOLTAGE
(see CODING EXAMPLE)

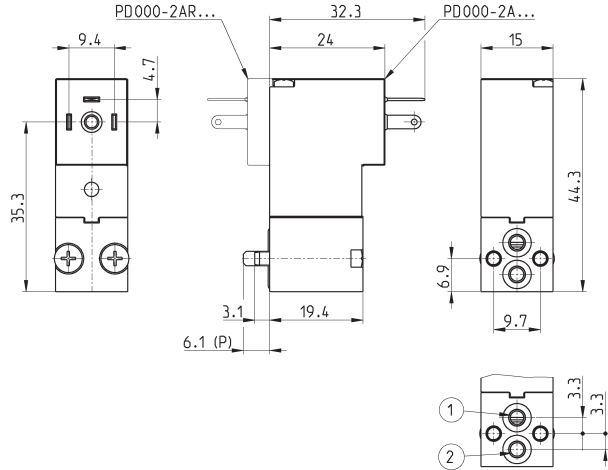
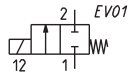

Mod.	Function	Orifice Ø (mm)	kv (l/min)	Min ÷ max pressure (bar)	Power (W)	ED (%)
PD000-2A1-*5*	2/2 NC	0.8	0.39	0 ÷ 12	1	100
PD000-2AR1-*5*	2/2 NC	0.8	0.39	0 ÷ 12	1	100
PD000-2A2-*5*	2/2 NC	1.2	0.54	0 ÷ 12	2	100
PD000-2AR2-*5*	2/2 NC	1.2	0.54	0 ÷ 12	2	100
PD000-2A3-*5*	2/2 NC	1.6	0.70	0 ÷ 7	2	100
PD000-2AR3-*5*	2/2 NC	1.6	0.70	0 ÷ 7	2	100
PD000-2A4-*5*	2/2 NC	2.0	1.31	0 ÷ 6	4	50
PD000-2AR4-*5*	2/2 NC	2.0	1.31	0 ÷ 6	4	50
PD000-2A5-*5*	2/2 NC	2.5	1.93	0 ÷ 4	4	50
PD000-2AR5-*5*	2/2 NC	2.5	1.93	0 ÷ 4	4	50

Series PD solenoid valve - aluminium body - bottom interface



Supplied with:
1x interface seal
2x M3x8 screws for mounting on metal

For vacuum applications connect the suction source to port 2

* add
- SEAL MATERIAL
- VOLTAGE
(see CODING EXAMPLE)

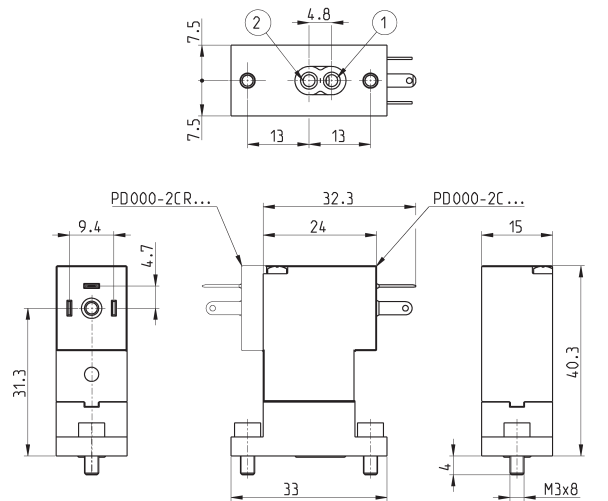
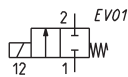

Mod.	Function	Orifice Ø (mm)	kv (l/min)	Min ÷ max pressure (bar)	Power (W)	ED (%)
PD000-2C1-*5*	2/2 NC	0.8	0.39	0 ÷ 12	1	100
PD000-2CR1-*5*	2/2 NC	0.8	0.39	0 ÷ 12	1	100
PD000-2C2-*5*	2/2 NC	1.2	0.54	0 ÷ 12	2	100
PD000-2CR2-*5*	2/2 NC	1.2	0.54	0 ÷ 12	2	100
PD000-2C3-*5*	2/2 NC	1.6	0.70	0 ÷ 7	2	100
PD000-2CR3-*5*	2/2 NC	1.6	0.70	0 ÷ 7	2	100
PD000-2C4-*5*	2/2 NC	2.0	1.31	0 ÷ 6	4	50
PD000-2CR4-*5*	2/2 NC	2.0	1.31	0 ÷ 6	4	50
PD000-2C5-*5*	2/2 NC	2.5	1.93	0 ÷ 4	4	50
PD000-2CR5-*5*	2/2 NC	2.5	1.93	0 ÷ 4	4	50

New

Series PD solenoid valve - POM body - bottom interface



Supplied with:
2x O-Rings
1x mounting clip

For vacuum applications connect the suction source to port 2

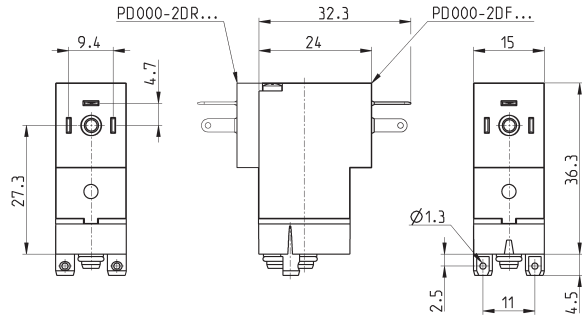
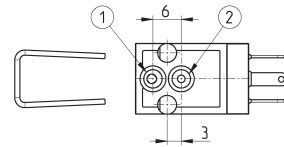

* add
- VOLTAGE
(see CODING EXAMPLE)

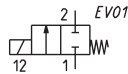

Mod.	Function	Orifice Ø (mm)	kv (l/min)	Min ÷ max pressure (bar)	Power (W)	ED (%)
PD000-2DF3-E5*	2/2 NC	1.6	0.72	0 ÷ 6	2	100
PD000-2DR3-E5*	2/2 NC	1.6	0.72	0 ÷ 6	2	100

Series PD solenoid valve - brass body - M5 threaded ports



For vacuum applications connect the suction source to port 2

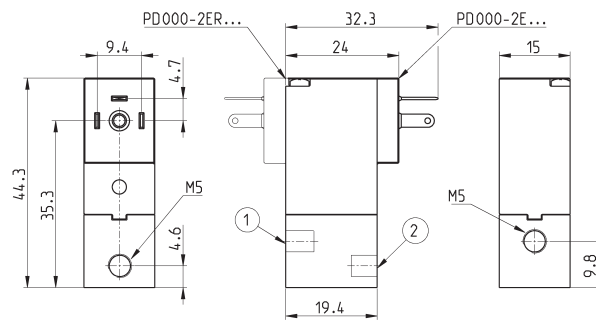
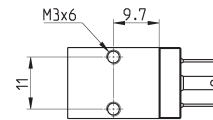

* add
- SEAL MATERIAL
- VOLTAGE
(see CODING EXAMPLE)

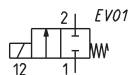

Mod.	Function	Orifice Ø (mm)	kv (l/min)	Min ÷ max pressure (bar)	Power (W)	ED (%)
PD000-2E1-*5*	2/2 NC	0.8	0.39	0 ÷ 12	1	100
PD000-2E1R-*5*	2/2 NC	0.8	0.39	0 ÷ 12	1	100
PD000-2E2-*5*	2/2 NC	1.2	0.54	0 ÷ 12	2	100
PD000-2E2R-*5*	2/2 NC	1.2	0.54	0 ÷ 12	2	100
PD000-2E3-*5*	2/2 NC	1.6	0.70	0 ÷ 7	2	100
PD000-2E3R-*5*	2/2 NC	1.6	0.70	0 ÷ 7	2	100

Single sub-base for Series PD lateral interface



Single sub-base suitable for 2-way solenoid valves Series PD and PL models PD000-2A..., PL000-9B...
Use solenoid valves with fixing screws for metal (see codification page)

Material: anodized aluminium
Connections: G1/8 threads

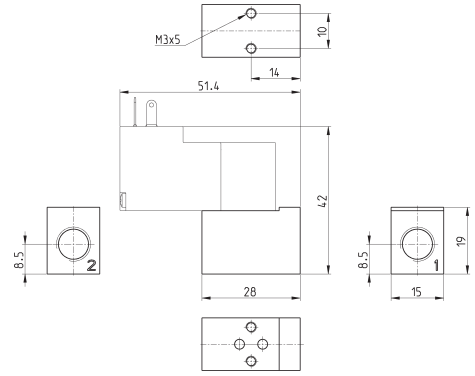

Mod.
PDA01-1/8

Single sub-base for Series PD bottom interface



Single sub-base suitable for Series PD 2-way solenoid valve models PD000-2C... and PD000-2CR...

Material: anodized aluminium
Connections: G1/8 threads

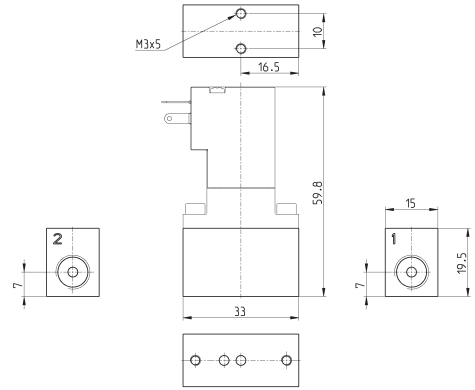

Mod.
PDC01-1/8

Single sub-base for Series PD bottom interface



Single sub-base suitable for Series PD 2-way solenoid valve models PD000-2DF... and PD000-2DR...

Material: anodized aluminium
Connections: G1/8 threads

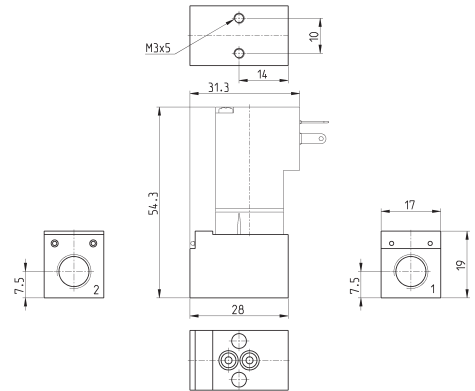

Mod.
PDD01-1/8

Connector Mod. 125-... - industrial std. 9.4 mm

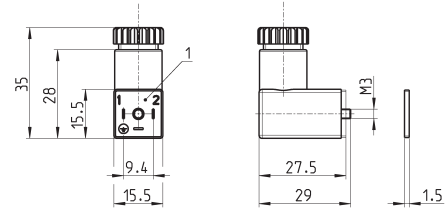

Mod.	description	colour	working voltage	cable gland	tightening torque
125-601	connector, diode + Led	transparent	10/50 V DC	PG7	0.3 Nm
125-701	connector, varistor + Led	transparent	24 V AC/DC	PG7	0.3 Nm
125-800	connector, without electronics	black	-	PG7	0.3 Nm

1 = 90° adjustable connector

Connector Mod. 125-... - industrial std. 9.4 mm - 90° cable



The internal rectifier circuit of the connector Mod. 125-900 allows to use solenoid valves with different AC voltage, even if the voltage indicated on the solenoid valve is DC.

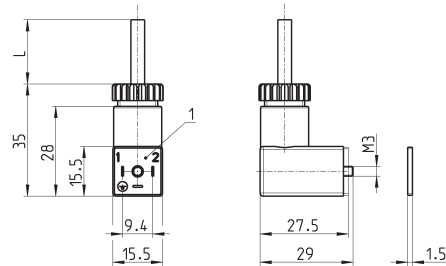

Mod.	description	colour	working voltage	cable length [L]	cable gland	tightening torque
125-501-2	moulded cable with diode + Led	black	10/50 V DC	2000 mm	-	0.3 Nm
125-550-1	moulded cable, without electronics	black	-	1000 mm	-	0.3 Nm
125-601-2	pre-wired cable, diode + Led	transparent	10/50 V DC	2000 mm	PG7	0.3 Nm
125-571-3	moulded cable, varistor + Led	black	24 V AC/DC	3000 mm	-	0.3 Nm
125-900	pre-wired cable with voltage rectifier	black	6 V - 110 V AC/DC	2000 mm	PG7	0.3 Nm

1 = 90° adjustable connector

Connector Mod. 125-... - industrial std. 9.4 mm - in-line cable

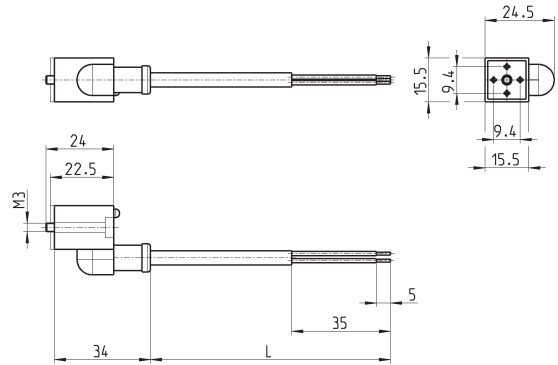

Mod.	description	colour	working voltage	cable length [L]	cable gland	tightening torque
125-503-2	in-line moulded cable, with diode + Led	black	24 V DC	2000 mm	-	0.3 Nm
125-503-5	in-line moulded cable, with diode + Led	black	24 V DC	5000 mm	-	0.3 Nm
125-553-2	in-line moulded cable, without electronics	black	-	2000 mm	-	0.3 Nm
125-553-5	in-line moulded cable, without electronics	black	-	5000 mm	-	0.3 Nm

Conn. Mod. 125-... - ind. std. 9.4 mm - in-line cable+rectifier

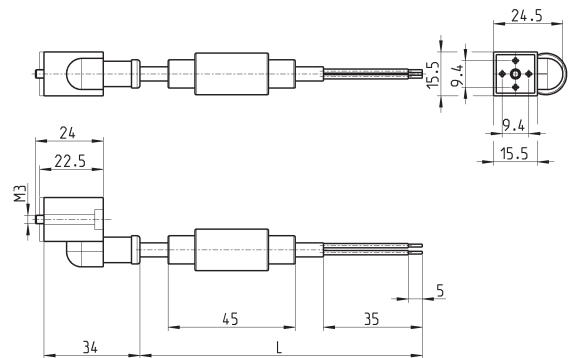

Mod.	description	colour	working voltage	cable length [L]	cable gland	tightening torque
125-903-2	in-line moulded cable with voltage rectifier	black	6 V - 230 V AC/DC	2000 mm	-	0.3 Nm
125-903-5	in-line moulded cable with voltage rectifier	black	6 V - 230 V AC/DC	5000 mm	-	0.3 Nm

Series PDV diaphragm isolation valves directly operated

2/2-way - Normally Closed (NC)

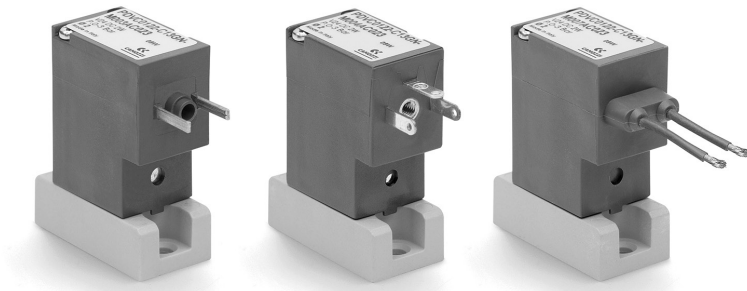

- » Suitable to be used with neutral or aggressive fluids
- » Suitable for specific applications on medical and analytical equipment or instruments
- » Compact design

To choose the most suitable model for a specific application, check the chemical compatibility of the medium with the available materials of body and seals.

Series PDV directly operated solenoid valve is available with several nominal diameters and in three different versions according to the electrical connection. Moreover, the fluid separation membrane protects the medium from extreme changes of temperature due to heating of the solenoid.

GENERAL DATA

TECHNICAL FEATURES

Function	2/2 NC
Operation	directly operated with fluid separation membrane on subbase
Pneumatic connections	0.8 ... 2 mm
Orifice diameter	0.25 ... 0.8
Flow coefficient kv (l/min)	0 ... 7 bar
Operating pressure	10 ÷ 50 °C (FKM/EPDM) / 20 ÷ 50 °C (FFKM)
Operating temperature	inert or corrosive liquids and gases compatible with the materials in contact
Media	≤ 15 ms
Response time	in any position
Installation	

MATERIALS IN CONTACT WITH THE MEDIUM

Body	PEEK
Seals	FKM - EPDM - FFKM

ELECTRICAL FEATURES

Voltage	6 ... 24 V DC - other voltages on demand
Voltage tolerance	±10%
Power consumption	2 W
Duty cycle	ED 100%
Electrical connection	industrial standard (9.4 mm), DIN EN 175 301-803-C (8 mm), 300 mm flying leads
Protection class	IP65 with connector

Special versions available on request

CODING EXAMPLE

PDV	C0	1	22	-	B7	3	G	N	-	M	00	4A	C023
------------	-----------	----------	-----------	----------	-----------	----------	----------	----------	----------	----------	-----------	-----------	-------------

PDV	SERIES		
C0	BODY DESIGN C0 = body with interface for subbase		
1	NUMBER OF WAYS - FUNCTIONS 1 = 2/2-way - NC		
22	PNEUMATIC CONNECTIONS 22 = PDV-type interface, 2-way		
B7	ORIFICE DIAMETER A7 = Ø 0.8 mm B3 = Ø 1.2 mm B7 = Ø 1.6 mm C1 = Ø 2.0 mm		
3	SEAL MATERIAL 3 = FKM 4 = EPDM 5 = FFKM		
G	BODY MATERIAL G = PEEK		
N	MANUAL OVERRIDE N = not foreseen		
M	FIXING M = fixing screws for metal		
00	OPTIONS 00 = none		
4A	ELECTRICAL CONNECTION 3A = DIN EN 175 301-803-C (8 mm) 4A = industrial standard (9.4 mm) 7A = 300 mm flying leads 3C = DIN EN 175 301-803-C (8 mm) with coil rotated 180° 4C = industrial standard (9.4 mm) with coil rotated 180° 7C = 300 mm flying leads with coil rotated 180°		
C023	VOLTAGE - POWER CONSUMPTION C017 = 6 V DC - 2 W C020 = 12 V DC - 2 W C023 = 24 V DC - 2 W		
	OPTIONS = standard OX2 = for oxygen (non-volatile residue less than 33 mg / m2)		

Series PDV solenoid valve - 2/2-way NC - industrial standard (9.4 mm)



Supplied with:
 1x interface seal
 2x M3x8 screws for mounting on metal

* add
 - ELECTRICAL CONNECTION
 - VOLTAGE
 (see CODING EXAMPLE)

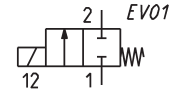

1 = inlet
 2 = outlet

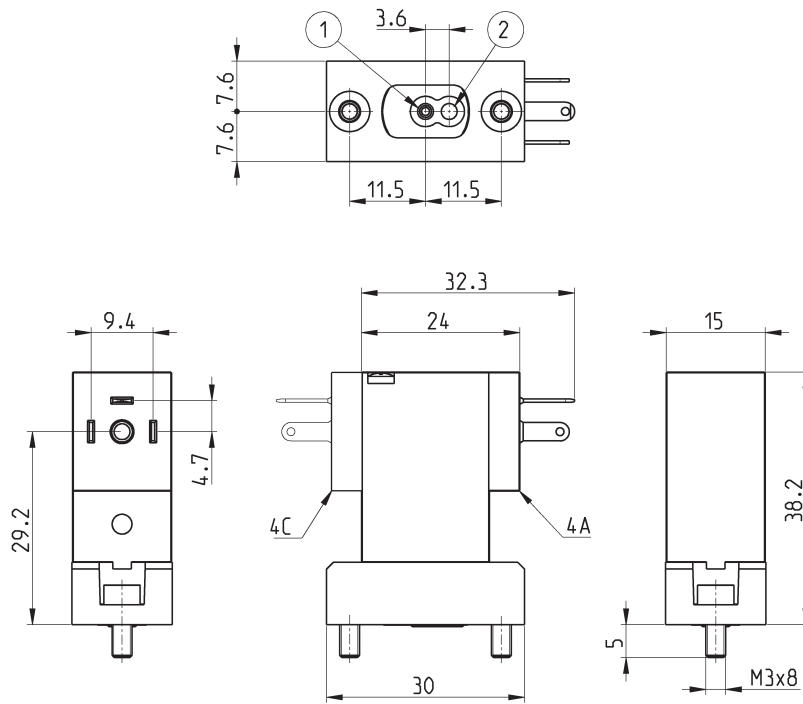

Mod.	Orifice Ø (mm)	kv (l/min)	Min ÷ max pressure (bar)	Maximum back pressure (bar)	Body material	Seal material
PDVC0122-A73GN-M00*	0.8	0.25	0 ÷ 7.0	1.2	PEEK	FKM
PDVC0122-A74GN-M00*	0.8	0.25	0 ÷ 7.0	1.2	PEEK	EPDM
PDVC0122-A75GN-M00*	0.8	0.25	0 ÷ 3.0	0.6	PEEK	FFKM
PDVC0122-B33GN-M00*	1.2	0.55	0 ÷ 4.5	1.2	PEEK	FKM
PDVC0122-B34GN-M00*	1.2	0.55	0 ÷ 4.5	1.2	PEEK	EPDM
PDVC0122-B35GN-M00*	1.2	0.55	0 ÷ 2.5	0.8	PEEK	FFKM
PDVC0122-B73GN-M00*	1.6	0.65	0 ÷ 4.0	1.2	PEEK	FKM
PDVC0122-B74GN-M00*	1.6	0.65	0 ÷ 4.0	1.2	PEEK	EPDM
PDVC0122-B75GN-M00*	1.6	0.65	0 ÷ 1.8	0.8	PEEK	FFKM
PDVC0122-C13GN-M00*	2.0	0.80	0 ÷ 3.0	1.2	PEEK	FKM
PDVC0122-C14GN-M00*	2.0	0.80	0 ÷ 3.0	1.2	PEEK	EPDM
PDVC0122-C15GN-M00*	2.0	0.80	0 ÷ 1.2	0.8	PEEK	FFKM

Series PDV solenoid valve - 2/2-way NC - DIN EN 175 301-803-C (8 mm)



Supplied with:
1x interface seal
2x M3x8 screws for mounting on metal

* add
- ELECTRICAL CONNECTION
- VOLTAGE
(see CODING EXAMPLE)

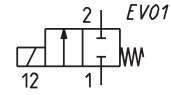

1 = inlet
2 = outlet

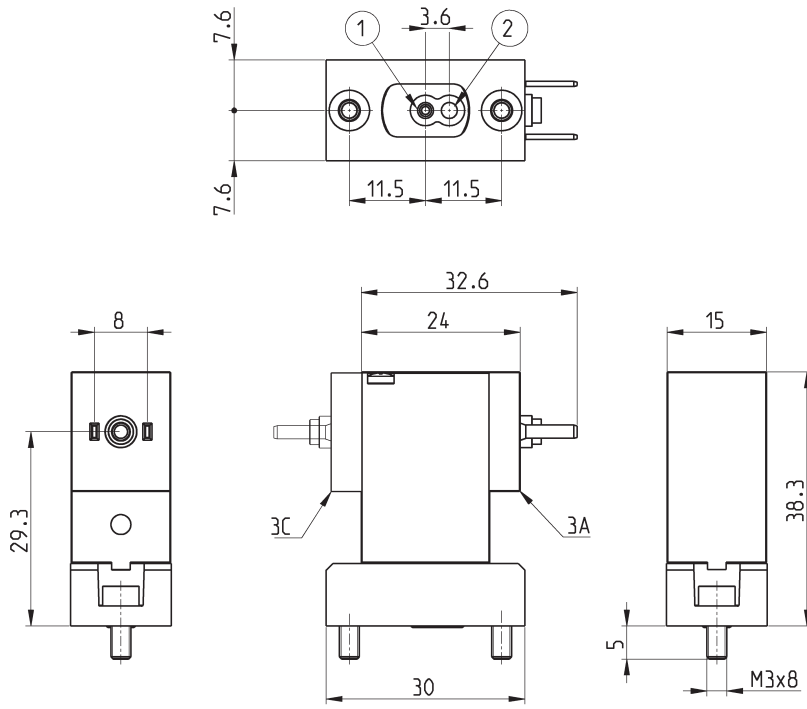

Mod.	Orifice Ø (mm)	kv (l/min)	Min ÷ max pressure (bar)	Maximum back pressure (bar)	Body material	Seal material
PDVC0122-A73GN-M00*	0.8	0.25	0 ÷ 7.0	1.2	PEEK	FKM
PDVC0122-A74GN-M00*	0.8	0.25	0 ÷ 7.0	1.2	PEEK	EPDM
PDVC0122-A75GN-M00*	0.8	0.25	0 ÷ 3.0	0.6	PEEK	FFKM
PDVC0122-B33GN-M00*	1.2	0.55	0 ÷ 4.5	1.2	PEEK	FKM
PDVC0122-B34GN-M00*	1.2	0.55	0 ÷ 4.5	1.2	PEEK	EPDM
PDVC0122-B35GN-M00*	1.2	0.55	0 ÷ 2.5	0.8	PEEK	FFKM
PDVC0122-B73GN-M00*	1.6	0.65	0 ÷ 4.0	1.2	PEEK	FKM
PDVC0122-B74GN-M00*	1.6	0.65	0 ÷ 4.0	1.2	PEEK	EPDM
PDVC0122-B75GN-M00*	1.6	0.65	0 ÷ 1.8	0.8	PEEK	FFKM
PDVC0122-C13GN-M00*	2.0	0.80	0 ÷ 3.0	1.2	PEEK	FKM
PDVC0122-C14GN-M00*	2.0	0.80	0 ÷ 3.0	1.2	PEEK	EPDM
PDVC0122-C15GN-M00*	2.0	0.80	0 ÷ 1.2	0.8	PEEK	FFKM

Series PDV solenoid valve - 2/2-way NC - 300 mm flying leads

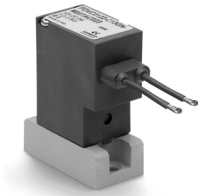

Supplied with:
1x interface seal
2x M3x8 screws for mounting on metal

* add
- ELECTRICAL CONNECTION
- VOLTAGE
(see CODING EXAMPLE)

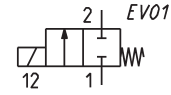

1 = inlet
2 = outlet

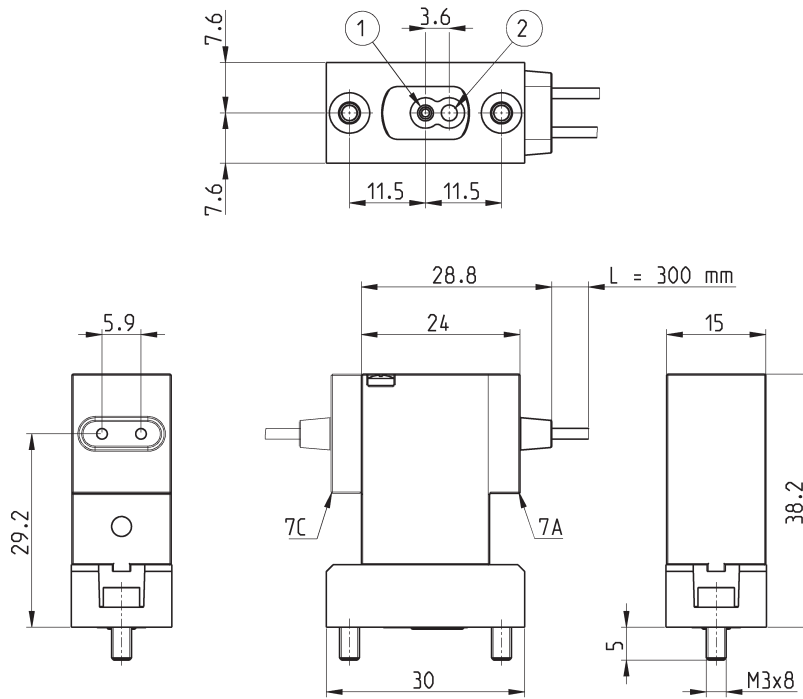

Mod.	Orifice Ø (mm)	kv (l/min)	Min ÷ max pressure (bar)	Maximum back pressure (bar)	Body material	Seal material
PDVC0122-A73GN-M00*	0.8	0.25	0 ÷ 7.0	1.2	PEEK	FKM
PDVC0122-A74GN-M00*	0.8	0.25	0 ÷ 7.0	1.2	PEEK	EPDM
PDVC0122-A75GN-M00*	0.8	0.25	0 ÷ 3.0	0.6	PEEK	FFKM
PDVC0122-B33GN-M00*	1.2	0.55	0 ÷ 4.5	1.2	PEEK	FKM
PDVC0122-B34GN-M00*	1.2	0.55	0 ÷ 4.5	1.2	PEEK	EPDM
PDVC0122-B35GN-M00*	1.2	0.55	0 ÷ 2.5	0.8	PEEK	FFKM
PDVC0122-B73GN-M00*	1.6	0.65	0 ÷ 4.0	1.2	PEEK	FKM
PDVC0122-B74GN-M00*	1.6	0.65	0 ÷ 4.0	1.2	PEEK	EPDM
PDVC0122-B75GN-M00*	1.6	0.65	0 ÷ 1.8	0.8	PEEK	FFKM
PDVC0122-C13GN-M00*	2.0	0.80	0 ÷ 3.0	1.2	PEEK	FKM
PDVC0122-C14GN-M00*	2.0	0.80	0 ÷ 3.0	1.2	PEEK	EPDM
PDVC0122-C15GN-M00*	2.0	0.80	0 ÷ 1.2	0.8	PEEK	FFKM

Single subbase for Series PDV solenoid valve



Material: PEEK
Connections: M5 or 1/4-28 UNF threads

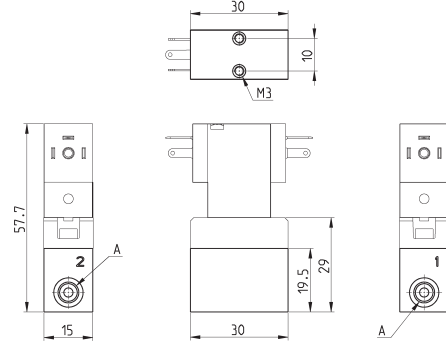

Mod.	Thread A
PDV001-1/4	1/4 - 28 UNF
PDV001-M5	M5

Connector Mod. 125-... - industrial std. 9.4 mm

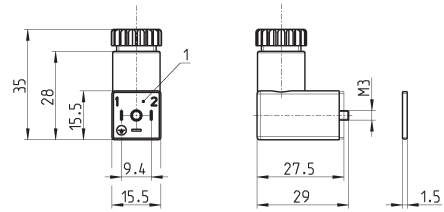

Mod.	description	colour	working voltage	cable gland	tightening torque
125-601	connector, diode + Led	transparent	10/50 V DC	PG7	0.3 Nm
125-701	connector, varistor + Led	transparent	24 V AC/DC	PG7	0.3 Nm
125-800	connector, without electronics	black	-	PG7	0.3 Nm

1 = 90° adjustable connector

Connector Mod. 125-... - industrial std. 9.4 mm - 90° cable



The internal rectifier circuit of the connector Mod. 125-900 allows to use solenoid valves with different AC voltage, even if the voltage indicated on the solenoid valve is DC.

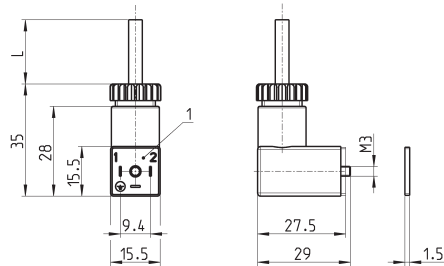

Mod.	description	colour	working voltage	cable length [L]	cable gland	tightening torque
125-501-2	moulded cable with diode + Led	black	10/50 V DC	2000 mm	-	0.3 Nm
125-550-1	moulded cable, without electronics	black	-	1000 mm	-	0.3 Nm
125-601-2	pre-wired cable, diode + Led	transparent	10/50 V DC	2000 mm	PG7	0.3 Nm
125-571-3	moulded cable, varistor + Led	black	24 V AC/DC	3000 mm	-	0.3 Nm
125-900	pre-wired cable with voltage rectifier	black	6 V - 110 V AC/DC	2000 mm	PG7	0.3 Nm

1 = 90° adjustable connector

Connector Mod. 125-... - industrial std. 9.4 mm - in-line cable

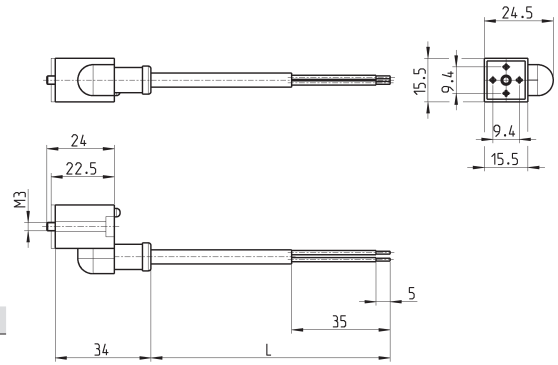

Mod.	description	colour	working voltage	cable length [L]	cable gland	tightening torque
125-503-2	in-line moulded cable, with diode + Led	black	24 V DC	2000 mm	-	0.3 Nm
125-503-5	in-line moulded cable, with diode + Led	black	24 V DC	5000 mm	-	0.3 Nm
125-553-2	in-line moulded cable, without electronics	black	-	2000 mm	-	0.3 Nm
125-553-5	in-line moulded cable, without electronics	black	-	5000 mm	-	0.3 Nm

Conn. Mod. 125-... - ind. std. 9.4 mm - in-line cable+rectifier

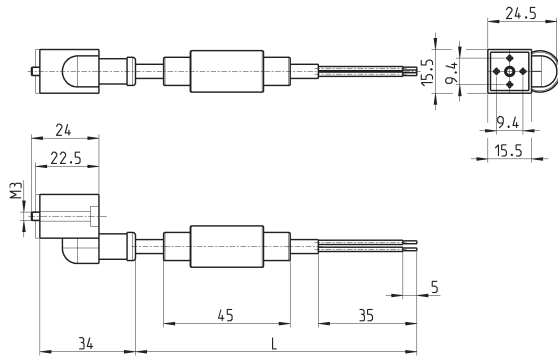

Mod.	description	colour	working voltage	cable length [L]	cable gland	tightening torque
125-903-2	in-line moulded cable with voltage rectifier	black	6 V - 230 V AC/DC	2000 mm	-	0.3 Nm
125-903-5	in-line moulded cable with voltage rectifier	black	6 V - 230 V AC/DC	5000 mm	-	0.3 Nm

Connector Mod. 126-... - DIN EN 175 301-803-C (8 mm)

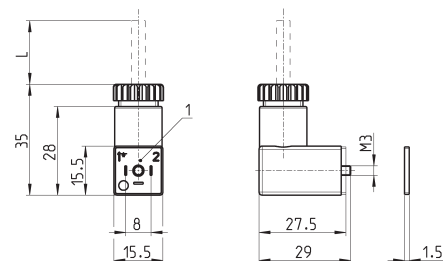

Mod.	description	colour	working voltage	cable length [L]	cable gland	tightening torque
126-550-1	moulded cable, without electronics	black	-	1000 mm	-	0.3 Nm
126-800	connector, without electronics	black	-	-	PG7	0.3 Nm
126-701	connector, varistor + Led	transparent	24 V AC/DC	-	PG7	0.3 Nm

1 = 90° adjustable connector

Series A directly operated solenoid valves

2/2-way - Normally Closed (NC) and Normally Open (NO)
3/2-way - Normally Closed (NC) and Normally Open (NO)

- » Ports: M5, G1/8, R1/8, cartridge Ø4
- » Bistable version also available (with magnetic memory)



Series A solenoid valves are of the directly operated type and can be used with dry or lubricated air. They are available in the 2/2 and 3/2-way versions with normally closed (NC) or normally open (NO) operation. As shown in the following tables, they are supplied in different versions according to the type of body, threaded ports and orifice. They can thus satisfy various operating and installation requirements.

The solenoid can be easily and quickly replaced without interfering with the pressurised part of the valve. On the same mechanical part different types of solenoids can be interchanged. The choice of solenoids determines the performance of the solenoid valve in terms of consumption and pressure.

GENERAL DATA

TECHNICAL FEATURES

Function	2/2 NC - 2/2 NO - 3/2 NC - 3/2 NO
Operation	direct acting poppet type
Pneumatic connections	M5, G1/8, R1/8 threads - Ø4 fittings - CNOMO and manifold interface- Ø6 barb fittings
Orifice diameter	1.2 ... 2.5 mm
Flow coefficient kv (l/min)	0.62 ... 2.0
Operating pressure	-0.9 ... 15 bar
Operating temperature	0 ÷ 60 °C (-20 °C with dry air)
Media	filtered air, class 5.4.4 according to ISO 8573-1 (max oil viscosity 32 cSt), inert gas
Response time	ON <15 ms - OFF <25 ms
Manual override	see tables
Installation	in any position

MATERIALS IN CONTACT WITH THE MEDIUM

Body	nickel-plated brass - burnished brass - PA6 - PBT
Seals	HNBR, FKM
Internal parts	stainless steel

ELECTRICAL FEATURES

Voltage	12 ... 110 V DC - 24 ... 380 V AC 50/60 Hz
Voltage tolerance	±10% (DC) / -15% ÷ +10% (AC)
Power consumption	3 ... 5 W (DC) / 3.5 ... 7 VA (AC)
Duty cycle	ED 100%
Insulation class	F (155°C)
Electrical connection	DIN EN 175 301-803-A - DIN EN 175 301-803-B
Protection class	IP65 with connector

Special versions available on demand

CODING EXAMPLE

A	3	3	1	-	0	C	2	-	U7	7
----------	----------	----------	----------	----------	----------	----------	----------	----------	-----------	----------

A	SERIES
3	<p>BODY DESIGN</p> <p>1 = 360° rotatable interface body (24x24 mm) 2 = fixed interface body (24x24 mm) 3 = threaded body 4 = threaded body with quick exhaust 5 = ISO interface body 6 = 360° rotatable interface body (16x16 mm) 7 = 360° rotatable interface body (21 mm) 8 = barb fittings connections body</p> <p>A = single manifold B = 2-part manifold C = 3-part manifold D = 4-part manifold E = 5-part manifold F = 6-part manifold G = 7-part manifold H = 8-part manifold K = 9-part manifold L = 10-part manifold M = 11-part manifold N = 12-part manifold P = 13-part manifold R = 14-part manifold S = 15-part manifold</p>
3	<p>NUMBER OF PORTS</p> <p>2 = 2 ways 3 = 3 ways</p>
1	<p>FUNCTION</p> <p>1 = NC - normally closed 2 = NO - normally open 3 = NO IN-LINE* - normally open</p>
0	<p>PORTS</p> <p>0 = M5 1 = G1/8 3 = M5-R1/8 4 = M5-R1/8 with manual override A = O-Rings rotatable interface B = O-Rings fixed interface C = G1/8-fittings Ø4 mm F = Ø6 mm barb fittings</p>
C	<p>ORIFICE DIAMETER</p> <p>C = Ø 1.2 - 1.4 - 1.5 mm D = Ø 2.0 mm E = Ø 2.5 mm</p>
2	<p>BODY MATERIAL</p> <p>2 = nickel-plated brass - burnished brass - aluminium 3 = PA6 - PBT technopolimers</p>
U7	<p>SOLENOIDS - OVERMOLDING MATERIAL / SIZE</p> <p>U7 = PET / 22 mm - solenoids available in standard version and in ATEX version for Zones 2-22 G7 = PA66 / 22 mm G9 = PA66 / 22 mm - solenoid for bistable function (not available for 2/2 NO function) A8 = PPS / 30 mm H8 = PA6 V0 / 30 mm - solenoids ATEX version for Zones 1-21</p>
7	<p>VOLTAGE - POWER CONSUMPTION</p> <p>See following page for U7 / G7 solenoids and dedicated section 2.35</p>

* 3/2 NO IN-LINE version: port position 1 - 2 - 3 are identical to port positions of 3/2 NC versions

PRESSURE RANGES AND SOLENOIDS - VALVES BODY MATCHING TABLE

For vacuum applications:

2/2-way function connect the suction source to port 2

3/2-way function connect the suction source to port 1

Mod.	Min ÷ max working pressure (bar) allowed with solenoids DC >3 W	Min ÷ max working pressure (bar) allowed with solenoids DC >4 W	Min ÷ max working pressure (bar) allowed with solenoids AC >3.5 VA
Function 2/2 NC			
A321-0C2- ^s	-0.9 ÷ 8	-0.9 ÷ 15	-0.9 ÷ 15
A321-1C2- ^s	-0.9 ÷ 8	-0.9 ÷ 15	-0.9 ÷ 15
A321-1D2- ^s	-0.9 ÷ 4	-0.9 ÷ 9	-0.9 ÷ 9
A321-1E2- ^s	-0.9 ÷ 1	-0.9 ÷ 6	-0.9 ÷ 6
A821-FE3- ^s	-0.9 ÷ 1	-0.9 ÷ 6	-0.9 ÷ 6
Function 2/2 NO			
A322-0C2- ^s	2 ÷ 10	-0.9 ÷ 10	-0.9 ÷ 10
A322-1C2- ^s	2 ÷ 10	-0.9 ÷ 10	-0.9 ÷ 10
Function 3/2 NC			
A131-AC2- ^s	-	-	-
A231-BC2- ^s	-	-	-
A331-0C2- ^s	2 ÷ 10	-0.9 ÷ 10	-0.9 ÷ 10
A331-1C2- ^s	2 ÷ 10	-0.9 ÷ 10	-0.9 ÷ 10
A331-1D2- ^s	-	-0.9 ÷ 6	-0.9 ÷ 6
A331-1E2- ^s	-	-0.9 ÷ 4	-0.9 ÷ 4
A331-3C2- ^s	2 ÷ 10	-0.9 ÷ 10	-0.9 ÷ 10
A331-4C2- ^s	2 ÷ 10	-0.9 ÷ 10	-0.9 ÷ 10
A431-1C2- ^s	2 ÷ 10	2 ÷ 10	2 ÷ 10
A531-BC2- ^s	2 ÷ 10	-0.9 ÷ 10	-0.9 ÷ 10
A631-AC2- ^s	2 ÷ 10	-0.9 ÷ 10	-0.9 ÷ 10
A731-AC2- ^s	2 ÷ 10	-0.9 ÷ 10	-0.9 ÷ 10
A831-FE3- ^s	-	-0.9 ÷ 4	-0.9 ÷ 4
AA31-0C2- ^s	2 ÷ 10	-0.9 ÷ 10	-0.9 ÷ 10
AA31-0C3- ^s	2 ÷ 8	-0.9 ÷ 8	-0.9 ÷ 8
AA31-CC2- ^s	2 ÷ 10	-0.9 ÷ 10	-0.9 ÷ 10
AA31-CC3- ^s	2 ÷ 8	-0.9 ÷ 8	-0.9 ÷ 8
Function 3/2 NO			
A332-0C2- ^s	-0.9 ÷ 7	-0.9 ÷ 7	-0.9 ÷ 7
A332-1C2- ^s	-0.9 ÷ 7	-0.9 ÷ 7	-0.9 ÷ 7
AA32-0C2- ^s	-0.9 ÷ 7	-0.9 ÷ 7	-0.9 ÷ 7
AA32-0C3- ^s	-0.9 ÷ 7	-0.9 ÷ 7	-0.9 ÷ 7
AA32-CC2- ^s	-0.9 ÷ 7	-0.9 ÷ 7	-0.9 ÷ 7
AA32-CC3- ^s	-0.9 ÷ 7	-0.9 ÷ 7	-0.9 ÷ 7
Function 3/2 NO IN-LINE			
A333-0C2- ^s	-0.9 ÷ 6	-	-0.9 ÷ 9
A333-1C2- ^s	-0.9 ÷ 6	-	-0.9 ÷ 9
AA33-0C2- ^s	-0.9 ÷ 6	-	-0.9 ÷ 9
AA33-0C3- ^s	-0.9 ÷ 6	-	-0.9 ÷ 8
AA33-CC2- ^s	-0.9 ÷ 6	-	-0.9 ÷ 9
AA33-CC3- ^s	-0.9 ÷ 6	-	-0.9 ÷ 8
Solenoids for functions 2/2 NC - 2/2 NO - 3/2 NC - 3/2 NO			
12 V DC - 3.1 W	G7H - U7H - U7HEX	-	-
24 V DC - 3.1 W	G77 - U77 - U77EX	-	-
48 V DC - 3.1 W	G79 - U79 - U79EX	-	-
110 V DC - 3.2 W	G710 - U710 - U710EX	-	-
6 V DC - 5.1 W	-	U71 - U71EX	-
12 V DC - 5 W	-	G72 - U72 - U72EX	-
24 V DC - 5 W	-	G73 - U73 - U73EX	-
48 V DC - 5.3 W	-	U74 - U74EX	-
72 V DC - 4.8 W	-	G7K - U7K - U7KEX	-
110 V DC - 4.2 W	-	G76 - U76 - U76EX	-
48 V 50/60 Hz - 3.8 VA	-	-	G77 - U77 - U77EX
110 V 50/60 Hz - 3.8 VA	-	-	G7K - U7K - U7KEX
125 V 50/60 Hz - 5.5 VA	-	-	G7K - U7K - U7KEX
230 V 50/60 Hz - 3.5 VA	-	-	G7J - U7J - U7JEX
240 V 50/60 Hz - 4 VA	-	-	G7J - U7J - U7JEX
Solenoids for 3/2 NO IN LINE functions			
12 VDC - 3.1 W	G7H1 - U7H1	-	-
24 V DC - 3.1 W	U771 - U771EX	-	-
72 V DC - 5.6 W	-	G7K1 - U7K1 - U7K1EX	-
48 V 50/60 Hz - 3.8 VA	-	-	G771 - U771 - U771EX
110 V 50/60 Hz - 5.8 VA	-	-	G7K1 - U7K1 - U7K1EX
125 V 50/60 Hz - 8.3 VA	-	-	G7K1 - U7K1 - U7K1EX

Nota: for AC voltages, the indicated pressure ranges refer to 50 Hz frequency. Please contact our technical dept. for use with with 60Hz frequency.

Series A solenoid valve - 2/2-way - Mod. A32



Available in the 2/2-way version NC (normally closed), NO (normally open).
 In the 2/2-way NO version the M5 threaded output port 2 is located on the upper side of the coil.

* choose the most suitable solenoid.

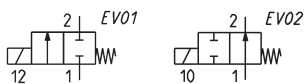
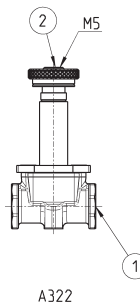
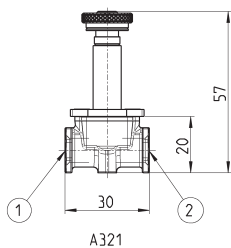
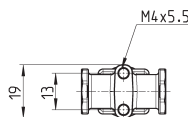

Mod.	Function	Ports	Orifice Ø (mm)	kv (l/min)	Body material	Manual override	Symbol
A321-0C2-*	2/2 NC	M5	1.5	0.77	nickel plated brass	no	EV01
A321-1C2-*	2/2 NC	G1/8	1.5	0.85	nickel plated brass	no	EV01
A321-1D2-*	2/2 NC	G1/8	2.0	1.55	nickel plated brass	no	EV01
A321-1E2-*	2/2 NC	G1/8	2.5	2.00	nickel plated brass	no	EV01
A322-0C2-*	2/2 NO	M5	1.8	1.08	nickel plated brass	no	EV02
A322-1C2-*	2/2 NO	G1/8	1.8	1.24	nickel plated brass	no	EV02

Series A solenoid valve - 3/2-way - Mod. A33



The 3/2-way NC and NO IN-LINE versions have inlet, outlet and exhaust ports in the same position.
 In the 3/2-way NO version, the M5 threaded inlet port 1, is located on the upper side of the coil.

* choose the most suitable solenoid.

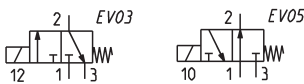
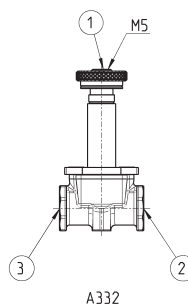
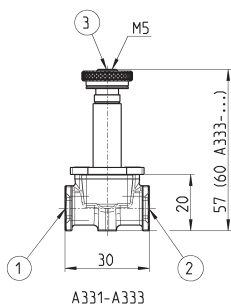
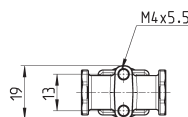

Mod.	Function	Ports	Orifice Ø (mm)	kv (l/min)	Body material	Manual override	Symbol
A331-0C2-*	3/2 NC	M5	1.5	0.77	nickel plated brass	no	EV03
A331-1C2-*	3/2 NC	G1/8	1.5	0.93	nickel plated brass	no	EV03
A331-1D2-*	3/2 NC	G1/8	2.0	1.45	nickel plated brass	no	EV03
A331-1E2-*	3/2 NC	G1/8	2.5	1.90	nickel plated brass	no	EV03
A332-0C2-*	3/2 NO	M5	1.5	0.85	nickel plated brass	no	EV05
A332-1C2-*	3/2 NO	M5-G1/8	1.5	0.85	nickel plated brass	no	EV05
A333-0C2-*	3/2 NO in line	M5	1.5	0.93	nickel plated brass	no	EV05
A333-1C2-*	3/2 NO IN-LINE	G1/8	1.5	0.93	nickel plated brass	no	EV05

Series A solenoid valve - 3/2-way - Mod. AA3 - modular brass body



3/2-way NC and NO IN-LINE versions with G1/8 common inlet port located on the valve body.
3/2-way NO versions with M5 single inlets located on the upper side of the coil.

* choose the most suitable solenoid.

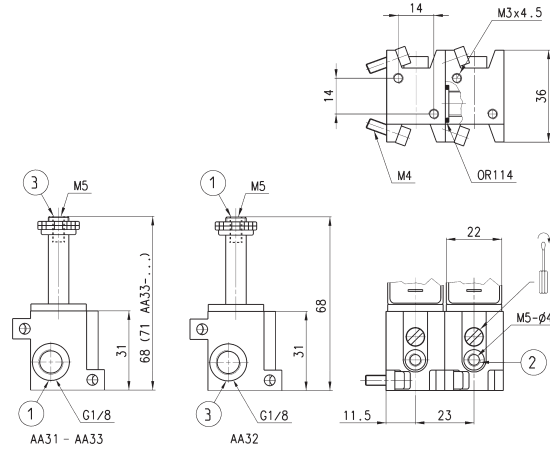

Mod.	Function	Ports	Orifice Ø (mm)	kv (l/min)	Body material	Manual override	Symbol
AA31-0C2-*	3/2 NC	G1/8-M5	1.5	0.85	nickel plated brass	bistable	EV08
AA31-CC2-*	3/2 NC	G1/8-Ø4	1.5	0.85	nickel plated brass	bistable	EV08
AA32-0C2-*	3/2 NO	M5-M5	1.4	0.75	nickel plated brass	bistable	EV05
AA32-CC2-*	3/2 NO	M5-Ø4	1.4	0.75	nickel plated brass	bistable	EV05
AA33-0C2-*	3/2 NO IN-LINE	G1/8-M5	1.5	1.00	nickel plated brass	no	EV05
AA33-CC2-*	3/2 NO IN-LINE	G1/8-Ø4	1.5	1.00	nickel plated brass	no	EV05

Series A solenoid valve - 3/2-way - Mod. AA3 - modular technopolymer body



3/2-way NC and NO IN-LINE versions with G1/8 common inlet port located on the valve body.
3/2-way NO versions with M5 single inlets located on the upper side of the coil.

* choose the most suitable solenoid.

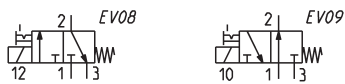
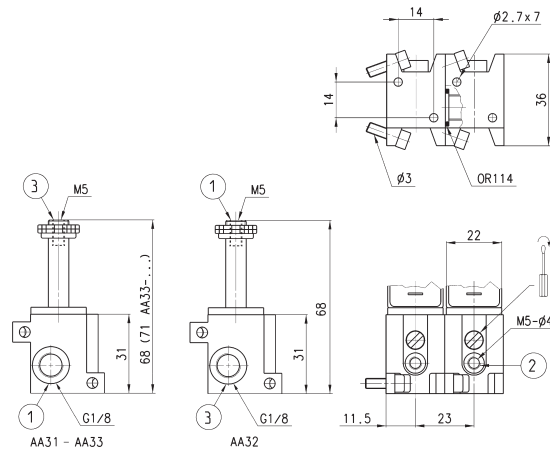

Mod.	Function	Ports	Orifice Ø (mm)	kv (l/min)	Body material	Manual override	Symbol
AA31-0C3-*	3/2 NC	G1/8-M5	1.5	0.85	PA6	bistable	EV08
AA31-CC3-*	3/2 NC	G1/8-Ø4	1.5	0.85	PA6	bistable	EV08
AA32-0C3-*	3/2 NO	M5-M5	1.4	0.75	PA6	bistable	EV05
AA32-CC3-*	3/2 NO	M5-Ø4	1.4	0.75	PA6	bistable	EV05
AA33-0C3-*	3/2 NO IN-LINE	G1/8-M5	1.5	1.00	PA6	no	EV05
AA33-CC3-*	3/2 NO IN-LINE	G1/8-Ø4	1.5	1.00	PA6	no	EV05

Series A solenoid valve - 3/2-way NC - Mod. A43 - quick exhaust



The 3/2-way NC solenoid valve, with G1/8 ports, incorporates a rapid exhaust valve. It is particularly suitable for operating small single-acting cylinders.

* choose the most suitable solenoid.

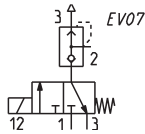
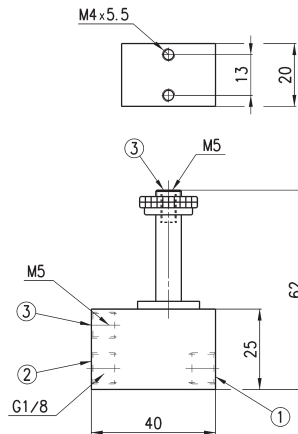

Mod.	Function	Ports	Orifice Ø (mm)	kv (L/min)	Body material	Manual override	Symbol
A431-1C2-*	3/2 NC	G1/8	1.5	0.77	aluminium	no	EV07

Series A solenoid valve - 3/2-way NC - Mod. A33



M5 thread inlet
R1/8 thread outlet
The valve can be screwed directly onto the component to be operated.

* choose the most suitable solenoid.

They are particularly suitable for the actuation of small single-acting cylinders and the operation of pneumatic valves with very low operating pressures.

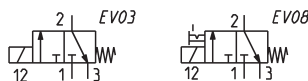
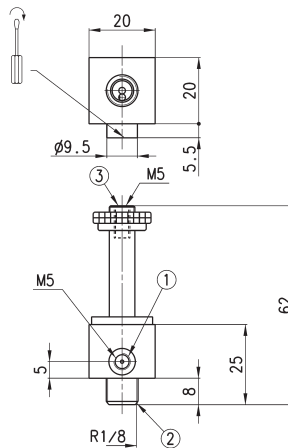

Mod.	Function	Ports	Orifice Ø (mm)	kv (L/min)	Body material	Manual override	Symbol
A331-3C2-*	3/2 NC	M5-R1/8	1.5	0.85	nickel plated brass	no	EV03
A331-4C2-*	3/2 NC	M5-R1/8	1.5	0.85	nickel plated brass	no	EV08

Series A solenoid valve - 3/2-way NC - Mod. A73 - rotatable interface

New



* choose the most suitable solenoid.

Ideal for direct installation on manifold by means of 2 screws. Seal ensured by 2 concentric O-Rings that allow 360° body orientation. Equipped with a bistable manual override.

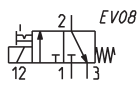
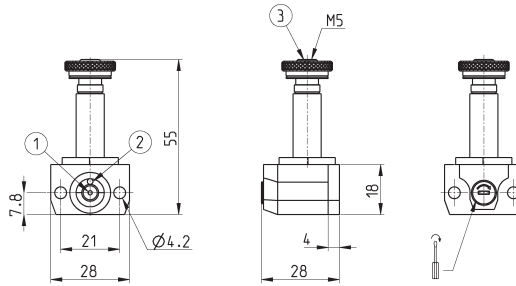

Mod.	Function	Interface	Orifice Ø (mm)	kv (l/min)	Body material	Manual override	Symbol
A731-AC2-*	3/2 NC	OR rotatable	1.2	0.62	PA6	bistable	EV08

Series A solenoid valve - 2/2 e 3/2-way NC - Mod. A82 e A83 - barb fittings

New



* Choose the most suitable solenoid.
 ** The performances shown in the table refer to the use with inlet from "2" and outlet from "1".

Solenoid valve with technopolymer body and integrated barb fittings for quick connections.

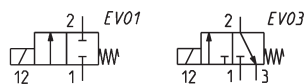
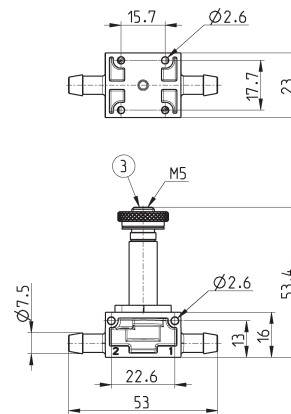

Mod.	Function	Ports	Orifice Ø (mm)	kv (l/min)	Body material	Manual override	Symbol
A821-FE3-*	2/2 NC	barb fittings Ø6	2.5	2.0	PBT	no	EV01
A831-FE3-*	3/2 NC **	barb fittings Ø6	2.5	1.8	PBT	no	EV03

Series A solenoid valve - 3/2-way - Mod. A231 - fixed interface



Equipped with a bistable manual override. Ideal for direct installation on manifold by means of 2 screws.

* choose the most suitable solenoid.

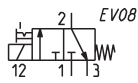
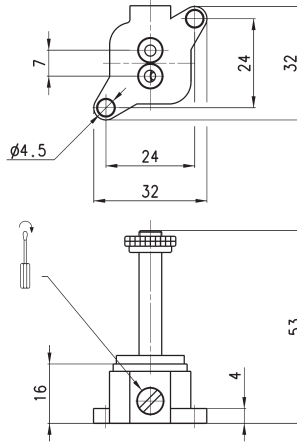

Mod.	Function	Interface	Orifice	Ø (mm)	kv (l/min)	Body	material	Manual	override	Symbol
A231-BC2-*	3/2 NC	OR fixed	1.5	1.5	1.1	nichel plated brass	bistable	EV08		

Series A solenoid valve - 3/2-way - Mod. A231 - rotatable interface



Equipped with a bistable manual override. Ideal for direct installation on manifold by means of 2 screws. Seal ensured by 2 concentric O-Rings that allow 360° body orientation.

* choose the most suitable solenoid.

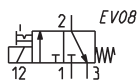
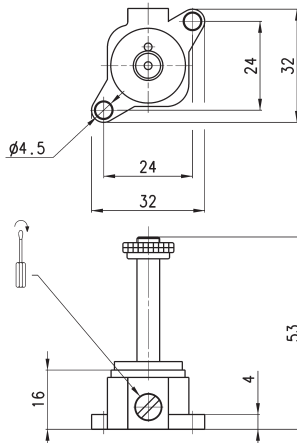

Mod.	Function	Interface	Orifice Ø (mm)	kv (l/min)	Body material	Manual override	Symbol
A131-AC2-*	3/2 NC	OR rotatable	1.5	1.1	nichel plated brass	bistable	EV08

Series 6 directly operated solenoid valves

2/2-way - Normally Closed (NC)

3/2-way - Normally Closed (NC), Normally Open (NO)



- » Ports: G1/8, G3/8, cartridge Ø4
- » Available also in version for the low temperatures up to -50°C

The bodies of these valves can be used either individually or in manifolds. The latter are provided with G1/8 threaded ports or an inbuilt diameter 4 cartridge (G3/8 for 2-way only).

Series 6 solenoid valves are available as 2/2 and 3/2-way, either NC or NO. These directly operated solenoid valves can be used either with or without lubrication.

GENERAL DATA

TECHNICAL FEATURES

Function	2/2 NC - 3/2 NC - 3/2 NO
Operation	direct acting poppet type
Pneumatic connections	G1/8, G3/8 threads - Ø4 fitting - CNOMO interface
Orifice diameter	2 ... 4 mm
Flow coefficient kv (l/min)	1.2 ... 5.4
Operating pressure	0 ÷ 4 ... 15 bar
Operating temperature	0 ÷ 60 °C (FKM seals) / -50 ÷ 50 °C (NBR seals)
Media	filtered air, class 5.4.4 (5.1.4 for versions -50°C) according to ISO 8573-1 (max oil viscosity 32 cSt), inert gas
Response time	ON <15 ms - OFF <15 ms
Manual override	see tables
Installation	in any position

MATERIALS IN CONTACT WITH THE MEDIUM

Body	nickel-plated brass - anodized aluminium
Seals	FKM (NBR for versions -50 °C)
Internal parts	stainless steel

ELECTRICAL FEATURES

Voltage	12 ... 110 V DC - 24 ... 230 V AC 50/60 Hz
Voltage tolerance	±10% (DC) - +10% ÷ -15% (AC)
Power consumption	10 W (DC) - 19 VA (inrush AC), 12 VA (holding AC)
Duty cycle	ED 100%
Insulation class	H (180°C)
Electrical connection	connector DIN EN 175 301-803-A
Protection class	IP65 with connector

Special versions available on demand

CODING EXAMPLE

6	3	8	M	-	105	-	A	6	B
----------	----------	----------	----------	----------	------------	----------	----------	----------	----------

6	SERIES
3	NUMBER OF PORTS AND FUNCTIONS 0 = interface 2 = 2/2-way - NC 3 = 3/2-way - NC 4 = 3/2-way - NO
8	CONNECTION 0 = interface 3 = G3/8 8 = G1/8 C = cartridge Ø 4
M	M = manifold
105	TYPE OF BODY 150 = threaded body G1/8 - orifice Ø 2 mm 15E = threaded body G3/8 - orifice Ø 2.5 mm 15F = threaded body G3/8 - orifice Ø 3 mm 15G = threaded body G3/8 - orifice Ø 4 mm 450 = rotatable interface body - Ø 2 mm orifice 45E = rotatable interface body - Ø 2.5 mm orifice 457 = fixed interface body - Ø 2 mm orifice 101 = single manifold 102 = manifold - 2 pieces 103 = manifold - 3 pieces 104 = manifold - 4 pieces 105 = manifold - 5 pieces 106 = manifold - 6 pieces 107 = manifold - 7 pieces 108 = manifold - 8 pieces 109 = manifold - 9 pieces 110 = manifold - 10 pieces 111 = manifold - 11 pieces 112 = manifold - 12 pieces 113 = manifold - 13 pieces 114 = manifold - 14 pieces 115 = manifold - 15 pieces
A	COIL MATERIAL: A = PPS
6	SOLENOID DIMENSIONS 6 = 32x32
B	VOLTAGE - POWER CONSUMPTION B = 24 V 50/60 Hz - 12 VA C = 48 V 50/60 Hz - 12 VA D = 110 V 50/60 Hz - 12 VA E = 230 V 50/60 Hz - 12 VA 2 = 12 V DC - 10 W 3 = 24 V DC - 10 W 4 = 48 V DC - 10 W 5 = 72 V DC - 10 W 6 = 110 V DC - 10 W 8 = 160 V DC - 10 W
	VERSIONS = standard LT = for low temperatures

Series 6 solenoid valve - 2/2 and 3/2-way NC - Mod. 628 - 638 - 648



These valves are particularly suitable for operating single-acting cylinders or for use as signal valves.

In the mod. 648-150-A6* (NO) connections 1 and 3 are inverted.

* add
- VOLTAGE
(see CODING EXAMPLE)

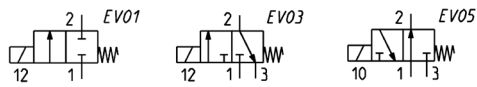
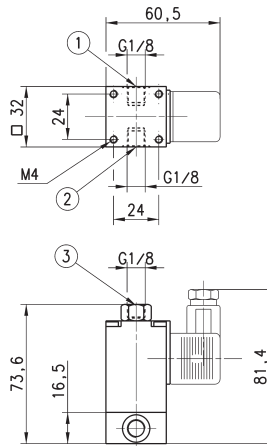

Mod.	Ports	Function	Orifice Ø (mm)	kv (l/min)	Qn (NL/min)	Pressure min-max (bar)	Symbol
628-150-A6*	G1/8	2/2 NC	2	2.0	130	0 ÷ 10 [DC] - 0 ÷ 7 [AC]	EV01
638-150-A6*	G1/8	3/2 NC	2	2.0	130	0 ÷ 10 [DC]	EV03
648-150-A6*	G1/8	3/2 NO	2	1.2	80	0 ÷ 8 [DC] - 0 ÷ 6 [AC]	EV05

Series 6 solenoid valve - 3/2-way NC - Mod. 638M - 63CM



These solenoid valves are equipped with a manual override and are available with G1/8 inlet ports and with G1/8 outlets or with a diameter 4 cartridge. The body is supplied complete with screws and O-ring.

* add
- VOLTAGE
(see CODING EXAMPLE)

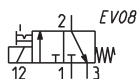
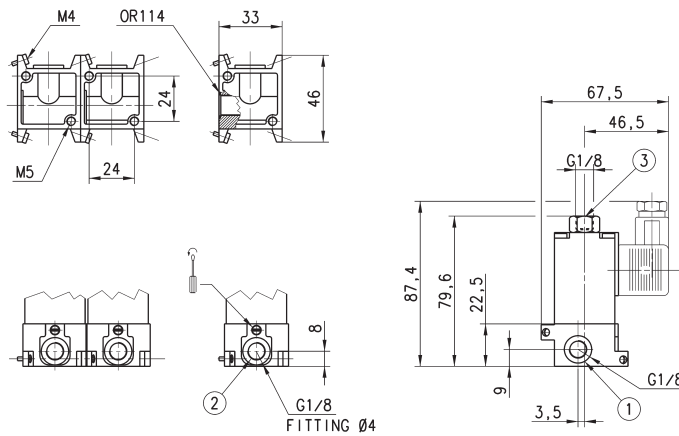

Mod.	Inlet	Outlet	Orifice Ø (mm)	kv (l/min)	Qn (NL/min)	Pressure min-max (bar)
638M-101-A6*	G1/8	G1/8	2	1.8	120	0 ÷ 10
63CM-101-A6*	G1/8	cartridge Ø 4	2	1.6	108	0 ÷ 10

Series 6 solenoid valve - 3/2-way NC - Mod. 600



These solenoid valves are equipped with an override and are available with two types of interface:
A = fixed interface
B = rotatable interface

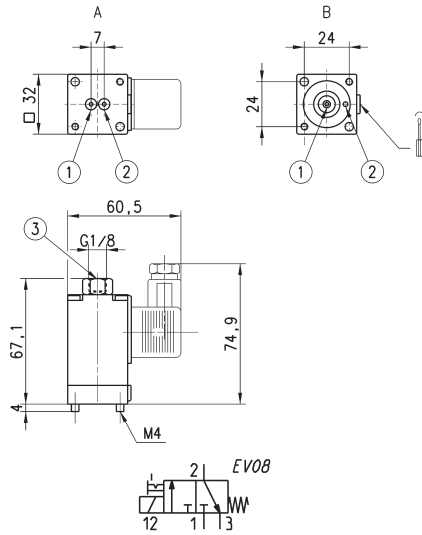

Mod.	Interface	Orifice \varnothing (mm)	kv (l/min)	Qn (Nl/min)	Pressure min-max (bar)
600-450-A6*	rotatable	2	1.6	106	0 ÷ 10
600-45E-A6*	rotatable	2.5	2.0	130	0 ÷ 8
600-457-A6*	fixed	2	1.6	106	0 ÷ 10

* add
- VOLTAGE
(see CODING EXAMPLE)

Series 6 solenoid valve - 2/2-way NC - Mod. 623

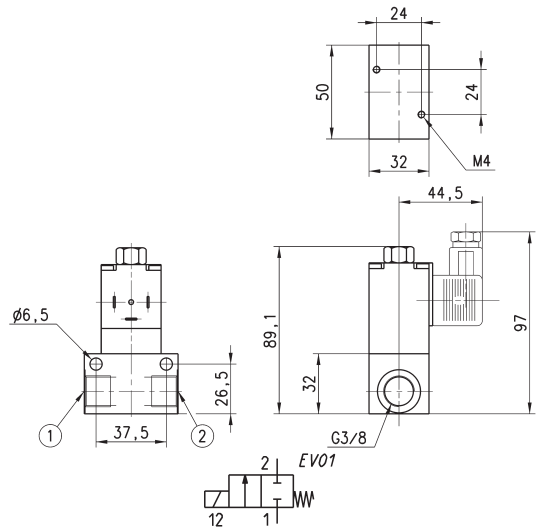

Mod.	Orifice \varnothing (mm)	kv (l/min)	Qn (Nl/min)	Min-max pressure (bar)
623-15E-A6*	2.5	3.4	220	0 ÷ 12 [AC 50Hz] - 0 ÷ 15 [DC]
623-15F-A6*	3	4.5	290	0 ÷ 10 [AC 50Hz] - 0 ÷ 14 [DC]
623-15G-A6*	4	5.4	350	0 ÷ 4 [AC 50Hz] - 0 ÷ 7 [DC]

* add
- VOLTAGE
(see CODING EXAMPLE)

Connector Mod. 124-... DIN EN 175 301-803-A



Protection class IP65

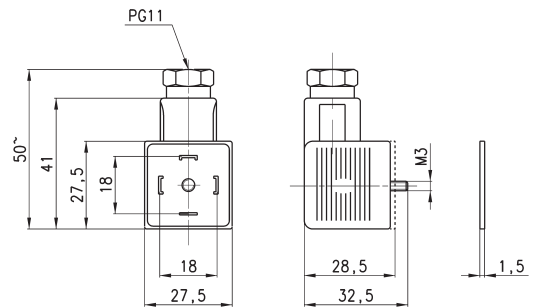

Mod.	description	colour	working voltage	cable gland	tightening torque
124-800	connector, without electronics	black	-	PG9/PG11	0.5 Nm
124-702	connector, varistor + Led	black	110 V AC/DC	PG9/PG11	0.5 Nm
124-701	connector, varistor + Led	black	24 V AC/DC	PG9/PG11	0.5 Nm
124-703	connector, varistor + Led	black	230 V AC/DC	PG9/PG11	0.5 Nm

Series CFB solenoid valves

New models

2/2-way - Normally Closed (NC) and Normally Open (NO)
3/2-way - Normally Closed (NC) and Normally Open (NO)



- » Solenoid valves for air and water
- » Great reliability over time, even in heavy working conditions

Series CFB solenoid valves for general purpose are available in the NC and NO version, 2/2 and 3/2-way.

Special versions are available on demand for the protection against the water hammer or with specific treatments for the interception of aggressive fluids.

The valve function is determined by a poppet or by a diaphragm with operation direct or indirect.

Different versions are available according to the nominal diameter and to the threaded ports, as shown in the following tables.

They can thus satisfy various requirements in terms of flow rates and working pressures.

GENERAL DATA

TECHNICAL FEATURES

Function	2/2 NC - 2/2 NO - 3/2 NC
Operation	direct acting poppet type - servo-assisted with diaphragm
Pneumatic connections	G1/8 ... G2 threads
Orifice diameter	1.4 ... 50 mm
Flow coefficient Kv (m ³ /h)	0.14 ... 45
Operating pressure	0 ÷ 0.8 ... 22 bar
Operating temperature	-10 ÷ 90 ... 140 °C
Media	air, water, liquid and gaseous fluids with max viscosity 37 cSt (5° E)
Response time	ON <15 ms - OFF <25 ms
Installation	in any position

MATERIALS IN CONTACT WITH THE MEDIUM

Body	brass (alimentary or anti-limestone nickel-platings on demand)
Seals	NBR (CFB-A, CFB-E) - FKM (CFB-B, CFB-D) - EPDM (on demand)
Internal parts	stainless steel - stainless steel and brass (CFB-D1)

ELECTRICAL FEATURES

Voltage	12 V DC, 24 V DC - 24 V 50 Hz, 110 V 50/60 Hz, 220/230 V 50/60 Hz
Voltage tolerance	±5% (DC) - ±10% (AC)
Power consumption	10 ... 30 W (DC) - 9 ... 29 VA (AC)
Duty cycle	ED 100%
Insulation class	H (180°C)
Electrical connection	DIN EN 175 301-803-A - DIN EN 175 301-803-B
Protection class	IP65 with connector

Special versions available on demand

It is recommended to use connections with internal diameters bigger than valve orifices, otherwise there may be a performance change.

CODING EXAMPLE

CFB	-	A	1	3	L	-	R	1	-	B7	E
------------	----------	----------	----------	----------	----------	----------	----------	----------	----------	-----------	----------

CFB	SERIES
A	OPERATION A = indirect B = direct with linked diaphragm D = direct E = indirect with coil for heavy-duty applications
1	NUMBER OF WAYS - POSITIONS 1 = 2/2-way - NO 2 = 2/2-way - NC 3 = 3/2-way - NC
3	CONNECTIONS 1 = G1/8 2 = G1/4 3 = G3/8 4 = G1/2 5 = G3/4 6 = G1 7 = G1 1/4 8 = G1 1/2 9 = G2
L	ORIFICE DIAMETER A = 1.4 mm B = 2 mm C = 2.5 mm D = 2.8 mm F = 4 mm G = 6 mm J = 8 mm L = 11.5 mm M = 13 mm N = 13.5 mm P = 18 mm R = 26 mm T = 32 mm X = 45 mm Z = 50 mm
R	SEALS MATERIAL R = NBR W = FKM E = EPDM (on demand)
1	BODY MATERIAL 1 = brass 2 = alimentary anti-limestone nickel-plated brass for high temperatures (on demand) 3 = alimentary nickel-plated brass (on demand)
B7	SOLENOID DIMENSION B7 = 22 mm B8 = 30 mm B9 = 36 mm
E	SOLENOID VOLTAGE B = 24 V AC 50 Hz D = 110 V AC 50/60 Hz E = 230 V AC 50/60 Hz 2 = 12 V DC 3 = 24 V DC

TABLE FOR THE COUPLING BETWEEN SOLENOIDS AND VALVES

For solenoids and their connectors voir la section dédiée.
 Coil mod. B8... / B9... - DIN EN 175 301-803-A = connector mod. 124-...
 Coil mod. B7... - DIN EN 175 301-803-B = connector mod. 122-...

Mod.	24V AC 50 Hz	110V AC 50/60 Hz	220/230V AC 50/60 Hz	12V DC	24V DC
Directly operated solenoid valve, 2/2 NC - 2/2 NO - 3/2 NC					
CFB-D21C-*	B8B (15VA)	B8D (15VA)	B8E (15VA)	B82 (19W)	B83 (19W)
CFB-D21F-*	B8B (15VA)	B8D (15VA)	B8E (15VA)	B82 (19W)	B83 (19W)
CFB-D22C-*	B8B (15VA)	B8D (15VA)	B8E (15VA)	B82 (19W)	B83 (19W)
CFB-D22F-*	B8B (15VA)	B8D (15VA)	B8E (15VA)	B82 (19W)	B83 (19W)
CFB-D22G-*	B8B (15VA)	B8D (15VA)	B8E (15VA)	B82 (19W)	B83 (19W)
CFB-D23I-*	B9B (29VA)	B9D (29VA)	B9E (29VA)**	not available	B93 (30W)
CFB-D24I-*	B9B (29VA)	B9D (29VA)	B9E (29VA)**	not available	B93 (30W)
CFB-D24M-*	B9B (29VA)	B9D (29VA)	B9E (29VA)**	not available	not available
Directly operated solenoid valve with constrained diaphragm, 2/2 NC					
CFB-B23L-*	B9B (29VA)	B9D (29VA)	B9E (29VA)	not available	B93 (30W)
CFB-B24N-*	B9B (29VA)	B9D (29VA)	B9E (29VA)	not available	B93 (30W)
CFB-B25P-*	B9B (29VA)	B9D (29VA)	B9E (29VA)	not available	B93 (30W)
CFB-B26R-*	B9B (29VA)	B9D (29VA)	B9E (29VA)	not available	B93 (30W)
Indirectly operated solenoid valve, 2/2 NC					
CFB-A23L-*	B7B (9VA)*	B7D (9VA)	B7E (9VA)	B72 (10W)	B73 (10W)
CFB-A24N-*	B7B (9VA)*	B7D (9VA)	B7E (9VA)	B72 (10W)	B73 (10W)
CFB-A25P-*	B7B (9VA)*	B7D (9VA)	B7E (9VA)	B72 (10W)	B73 (10W)
CFB-A26R-*	B7B (9VA)*	B7D (9VA)	B7E (9VA)	B72 (10W)	B73 (10W)
CFB-A27T-*	B8B (15VA)	B8D (15VA)	B8E (15VA)	B82 (19W)	B83 (19W)
CFB-A28X-*	B8B (15VA)	B8D (15VA)	B8E (15VA)	B82 (19W)	B83 (19W)
CFB-A29Z-*	B8B (15VA)	B8D (15VA)	B8E (15VA)	B82 (19W)	B83 (19W)
Indirectly operated solenoid valve, for heavy-duty applications, 2/2 NC					
CFB-E23L-*	B8B (15VA)	B8D (15VA)	B8E (15VA)	B82 (19W)	B83 (19W)
CFB-E24N-*	B8B (15VA)	B8D (15VA)	B8E (15VA)	B82 (19W)	B83 (19W)
CFB-E25P-*	B8B (15VA)	B8D (15VA)	B8E (15VA)	B82 (19W)	B83 (19W)
CFB-E26R-*	B8B (15VA)	B8D (15VA)	B8E (15VA)	B82 (19W)	B83 (19W)
CFB-E27T-*	B8B (15VA)	B8D (15VA)	B8E (15VA)	B82 (19W)	B83 (19W)
CFB-E28X-*	B8B (15VA)	B8D (15VA)	B8E (15VA)	B82 (19W)	B83 (19W)
CFB-E29Z-*	B8B (15VA)	B8D (15VA)	B8E (15VA)	B82 (19W)	B83 (19W)
Indirectly operated solenoid valve, 2/2 NO					
CFB-A13L-*	B7B (9VA)*	B7D (9VA)	B7E (9VA)	B721 (14W)	B731 (14W)
CFB-A14N-*	B7B (9VA)*	B7D (9VA)	B7E (9VA)	B721 (14W)	B731 (14W)
CFB-A15P-*	B7B (9VA)*	B7D (9VA)	B7E (9VA)	B721 (14W)	B731 (14W)
CFB-A17T-*	B8B (15VA)	B8D (15VA)	B8E (15VA)	B82 (19W)	B83 (19W)
CFB-A16R-*	B7B (9VA)*	B7D (9VA)	B7E (9VA)	B721 (14W)	B731 (14W)
CFB-A18X-*	B9B (29VA)	B9D (29VA)	B9E (29VA)	not available	B93 (30W)
CFB-A19Z-*	B9B (29VA)	B9D (29VA)	B9E (29VA)	not available	B93 (30W)
	* B7B solenoid with nominal bifrequency of 50/60 Hz		** only to be used with nominal frequency of 50 Hz		

Series CFB solenoid valve - directly operated - 2/2 NC-NO e 3/2 NC



The direct control of these solenoid valves enables them to work with operating pressures which are equal to zero. Ports: G1/8 and G1/2.

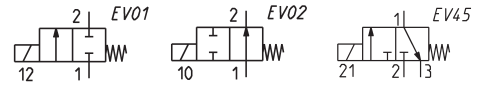

* = choose the suitable solenoid according to the TABLE FOR THE COUPLING BETWEEN SOLENOID AND VALVES
 ** = the performances shown in the table refer to the use with inlet from "2" and outlet from "1".
 *** = 0 ÷ 4 with B9... solenoid

SERIES CFB SOLENOID VALVES

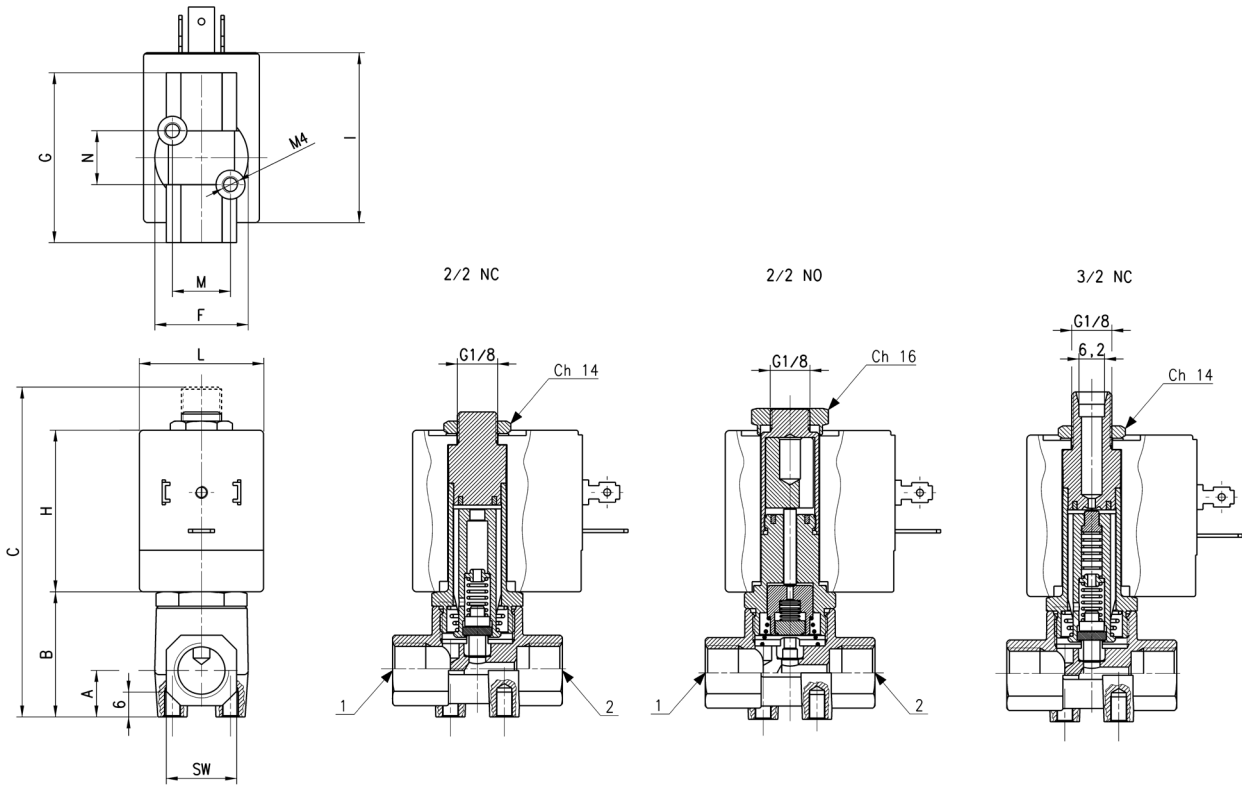

Mod.	Function	Ports	Ø Orifice (mm)	Kv (m³/h)	Pressure min-max (bar)	A	B	C	F	G	SW	H	I	L	N	M	Symbol
CFB-D21C-W1*	2/2 NC	G1/8	2.5	0.14	0 ÷ 15 [AC / DC]	11	30	73.8	23	41	17	39	41	30	13	14	EV01
CFB-D21F-W1*	2/2 NC	G1/8	4	0.25	0 ÷ 6 [AC / DC]	11	30	73.8	23	41	17	39	41	30	13	14	EV01
CFB-D22C-W1*	2/2 NC	G1/4	2.5	0.14	0 ÷ 15 [AC / DC]	11	30	73.8	23	41	17	39	41	30	13	14	EV01
CFB-D22F-W1*	2/2 NC	G1/4	4	0.25	0 ÷ 6 [AC / DC]	12	31.5	75	26	41	17	39	41	30	13	14	EV01
CFB-D22G-W1*	2/2 NC	G1/4	6	0.6	0 ÷ 2.5 [AC / DC] ***	12	31.5	75	26	41	17	39	41	30	13	14	EV01
CFB-D23J-R1*	2/2 NC	G3/8	8	1	0 ÷ 2 [AC] - 0 ÷ 0.8 [DC]	15	45	89	37	55	27	39	47	36	22	22	EV01
CFB-D24J-R1*	2/2 NC	G1/2	8	1	0 ÷ 2 [AC] - 0 ÷ 0.8 [DC]	15	45	89	37	55	27	39	47	36	22	22	EV01
CFB-D24M-R1*	2/2 NC	G1/2	13	2.4	0 ÷ 1 [AC] - /	15	45	89	37	55	27	39	47	36	22	22	EV01
CFB-D11A-W1*	2/2 NO	G1/8	1.4	0.07	0 ÷ 22 [AC 50Hz / DC]	11	30	75	23	41	17	39	41	30	13	14	EV02
CFB-D12D-W1*	2/2 NO	G1/4	2.8	0.20	0 ÷ 7.5 [AC 50Hz / DC]	11	30	75	23	41	17	39	41	30	13	14	EV02
CFB-D13J-W1*	2/2 NO	G3/8	8	1	0 ÷ 1.5 [AC 50Hz]	15	45	89	37	55	27	39	47	36	22	22	EV02
CFB-D31A-W1*	3/2 NC **	G1/8	1.4	0.06	0 ÷ 14 [AC / DC]	11	30	79.6	23	41	17	39	41	30	13	14	EV45
CFB-D31D-W1*	3/2 NC **	G1/8	2.8	0.14	0 ÷ 5 [AC / DC]	11	30	79.6	23	41	17	39	41	30	13	14	EV45
CFB-D32A-W1*	3/2 NC **	G1/4	1.4	0.06	0 ÷ 14 [AC / DC]	11	30	79.6	23	41	17	39	41	30	13	14	EV45
CFB-D32D-W1*	3/2 NC **	G1/4	2.8	0.14	0 ÷ 5 [AC / DC]	11	30	79.6	23	41	17	39	41	30	13	14	EV45

Series CFB solenoid valve - with linked diaphragm - 2/2 NC



The diaphragm which is linked to the mobile plunger is a good arrangement between high fluid flow rates and working pressures (zero pressures as well).
Ports: from G3/8 to G1.
The standard diaphragm is supplied in FKM.

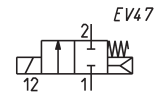
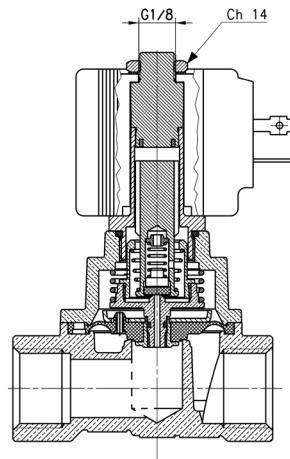
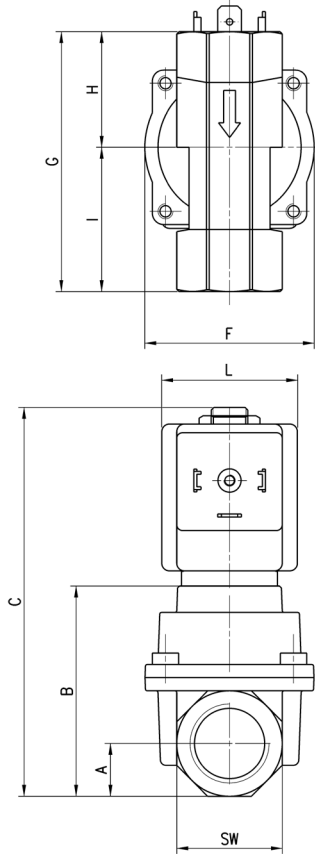

TABLE NOTE:
* = choose the suitable solenoid according to the TABLE FOR THE COUPLING BETWEEN SOLENOID AND VALVES



Mod.	Function	Ports	Ø Orifice (mm)	Kv (m ³ /h)	Pressure min÷max (bar)	A	B	C	F	G	H	I	L	SW
CFB-B23L-W1-*	2/2 NC	G3/8	11.5	2.1	0 ÷ 15 [AC] - 0 ÷ 8 [DC]	14	55.8	103.2	45	64	28.2	35.8	36	28
CFB-B24N-W1-*	2/2 NC	G1/2	13.5	2.5	0 ÷ 15 [AC] - 0 ÷ 8 [DC]	14	55.8	103.2	45	69	30.7	38.3	36	28
CFB-B25P-W1-*	2/2 NC	G3/4	18	5	0 ÷ 15 [AC] - 0 ÷ 5 [DC]	21	72	119.4	71	93	43.5	49.5	36	42
CFB-B26R-W1-*	2/2 NC	G1	26	8	0 ÷ 15 [AC] - 0 ÷ 5 [DC]	21	72	119.4	71	93	43.5	49.5	36	42

Series CFB - indirectly operated - 2/2 NC



The pilot of these indirectly operated solenoid valves controls the diaphragm position through a differential pressure. These valves are therefore particularly suitable for controlling high fluid flow rates and require very low working pressures to operate.
Ports: from G3/8 to G2.
The standard diaphragm is supplied in NBR.
On demand it can be supplied in FKM or EPDM.

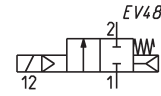
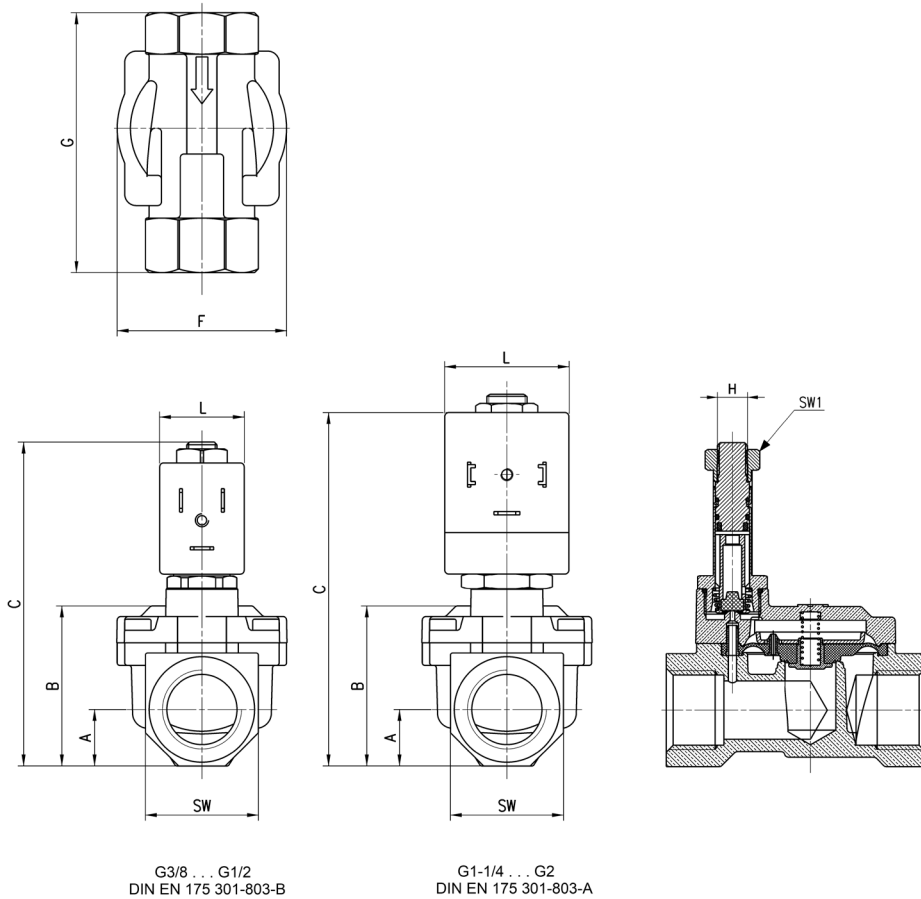

TABLE NOTE:
* = choose the suitable solenoid according to the TABLE FOR THE COUPLING BETWEEN SOLENOID AND VALVES



Mod.	Function	Ports	Ø Orifice (mm)	Kv (m³/h)	Pressure min÷max (bar)	A	B	C	F	G	H	L	SW	SW1
CFB-A23L-R1-*	2/2 NC	G3/8	11.5	2.6	0.1 ÷ 15 [AC / DC]	12	32.5	78.5	41.9	57	M8x0.75	22	24	13
CFB-A24N-R1-*	2/2 NC	G1/2	13.5	3.5	0.1 ÷ 15 [AC / DC]	15	39.7	85.7	45	69	M8x0.75	22	30	13
CFB-A25P-R1-*	2/2 NC	G3/4	18	5.8	0.2 ÷ 15 [AC / DC]	18	46.5	91.5	54.4	74	M8x0.75	22	34	13
CFB-A26R-R1-*	2/2 NC	G1	26	9.5	0.2 ÷ 12 [AC / DC]	22.5	59.8	104.5	71	93	M8x0.75	22	45	13
CFB-A27T-R1-*	2/2 NC	G1 1/4	32	12.5	0.4 ÷ 12 [AC 50 Hz / DC] - 0.4 ÷ 6 [AC 60 Hz]	27.5	73.5	130	86.6	111	G1/8	30	55	14
CFB-A28X-R1-*	2/2 NC	G1 1/2	45	31	0.4 ÷ 10 [AC 50 Hz / DC] - 0.4 ÷ 3.5 [AC 60 Hz]	31	85	138.3	110	138	G1/8	30	62	14
CFB-A29Z-R1-*	2/2 NC	G2	50	45	0.4 ÷ 10 [AC 50 Hz / DC] - 0.4 ÷ 3.5 [AC 60 Hz]	37.5	98.8	152	110	145	G1/8	30	75	14

Series CFB solenoid valve - indirectly op. for heavy-duty applications - 2/2 NC

New

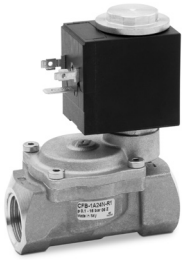

These solenoid valves have a solenoid protection system suitable to be used in particularly humid environments and in harsh conditions. The system consists of two gaskets placed above and below the coil and a lock nut that integrates the upper gasket. The standard diaphragm valve supplied is in NBR. On demand it can be supplied in FKM or EPDM.

TABLE NOTE:
* = choose the suitable solenoid according to the TABLE FOR THE COUPLING BETWEEN SOLENOID AND VALVES

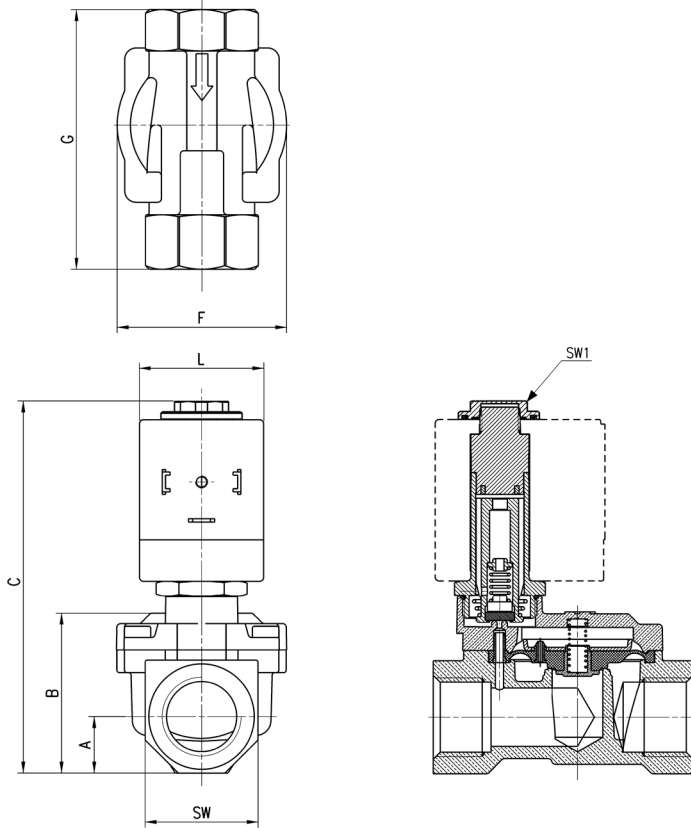

Mod.	Function	Ports	Ø Orifice (mm)	Kv (m³/h)	Pressure min÷max (bar)	A	B	C	F	G	H	L	SW	SW1
CFB-E23L-R1-*	2/2 NC	G3/8	11.5	2.6	0.1 ÷ 15 [AC / DC]	12	32.5	78.5	41.9	57	M8x0.75	30	24	13
CFB-E24N-R1-*	2/2 NC	G1/2	13.5	3.5	0.1 ÷ 15 [AC / DC]	15	39.7	85.7	45	69	M8x0.75	30	30	13
CFB-E25P-R1-*	2/2 NC	G3/4	18	5.8	0.2 ÷ 15 [AC / DC]	18	46.5	91.5	54.4	74	M8x0.75	30	34	13
CFB-E26R-R1-*	2/2 NC	G1	26	9.5	0.2 ÷ 12 [AC / DC]	22.5	59.8	104.5	71	93	M8x0.75	30	45	13
CFB-E27T-R1-*	2/2 NC	G1 1/4	32	12.5	0.4 ÷ 12 [AC 50 Hz / DC] - 0.4 ÷ 6 [AC 60 Hz]	27.5	73.5	130	86.6	111	G1/8	30	55	14
CFB-E28X-R1-*	2/2 NC	G1 1/2	45	31	0.4 ÷ 10 [AC 50 Hz / DC] - 0.4 ÷ 3.5 [AC 60 Hz]	31	85	138.3	110	138	G1/8	30	62	14
CFB-E29Z-R1-*	2/2 NC	G2	50	45	0.4 ÷ 10 [AC 50 Hz / DC] - 0.4 ÷ 3.5 [AC 60 Hz]	37.5	98.8	152	110	145	G1/8	30	75	14

Series CFB - indirectly operated - 2/2 NO



The pilot of these indirectly operated solenoid valves controls the diaphragm position through a differential pressure. These valves are therefore particularly suitable for controlling high fluid flow rates and require very low working pressures to operate.
Ports: from G3/8 to G2.
The standard diaphragm is supplied in NBR.
On demand it can be supplied in FKM or EPDM.

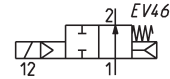
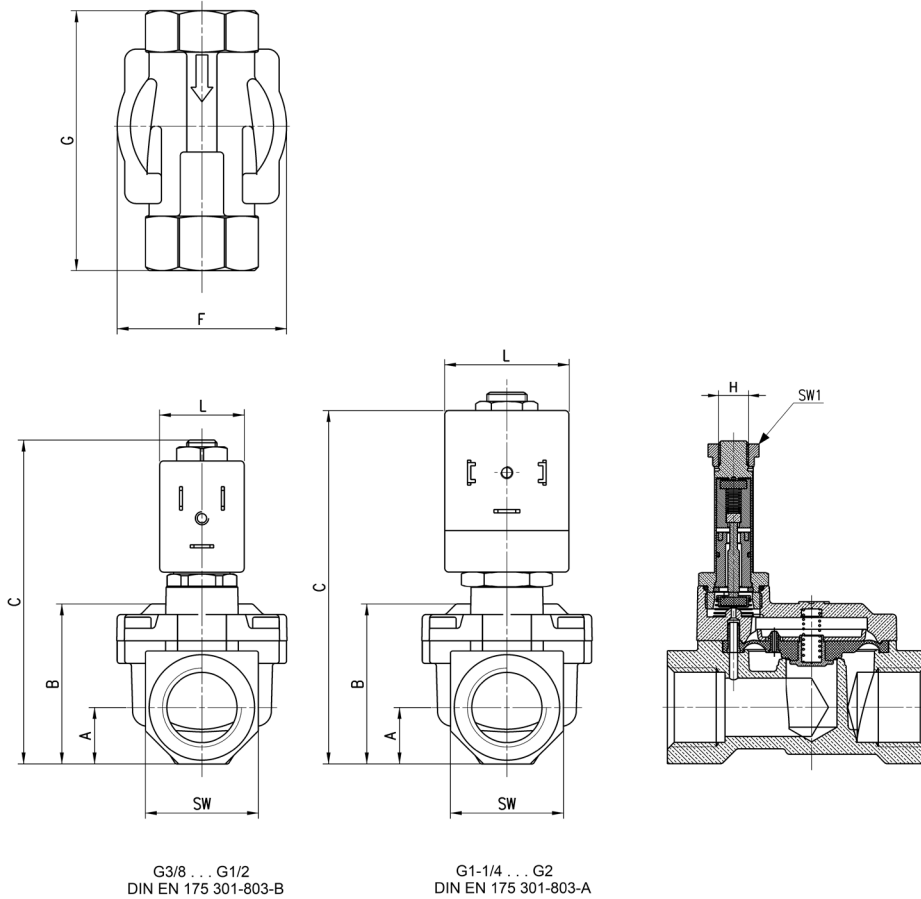

TABLE NOTE:
* = choose the suitable solenoid according to the TABLE FOR THE COUPLING BETWEEN SOLENOID AND VALVES



Mod.	Function	Ports	Ø Orifice (mm)	Kv (m³/h)	Pressure min÷max (bar)	A	B	C	F	G	H	L	SW	SW1
CFB-A13L-R1-*	2/2 NO	G3/8	11.5	2.6	0.1 ÷ 15 [AC / DC]	12	32.5	78.5	41.9	57	M8x0.75	22	24	13.5
CFB-A14N-R1-*	2/2 NO	G1/2	13.5	3.5	0.1 ÷ 15 [AC / DC]	15	39.7	85.7	45	69	M8x0.75	22	30	13.5
CFB-A15P-R1-*	2/2 NO	G3/4	18	5.8	0.2 ÷ 15 [AC / DC]	18	46.5	92.7	54.4	74	M8x0.75	22	36	13.5
CFB-A16R-R1-*	2/2 NO	G1	26	9.5	0.2 ÷ 12 [AC / DC]	22.5	59.8	104.5	71	93	M8x0.75	22	45	13.5
CFB-A17T-R1-*	2/2 NO	G1 1/4	32	12.5	0.4 ÷ 12 [AC / DC]	27.5	73.5	130	86.6	111	G1/8	30	55	14
CFB-A18X-R1-*	2/2 NO	G1 1/2	45	31	0.4 ÷ 10 [AC / DC]	31	85	138.3	110	138	G1/8	36	62	14
CFB-A19Z-R1-*	2/2 NO	G2	50	45	0.4 ÷ 10 [AC / DC]	37.5	98.8	152	110	145	G1/8	36	75	14

Series CFB stainless steel solenoid valves

2/2-way - Normally Closed (NC)

3/2-way - Normally Closed (NC)

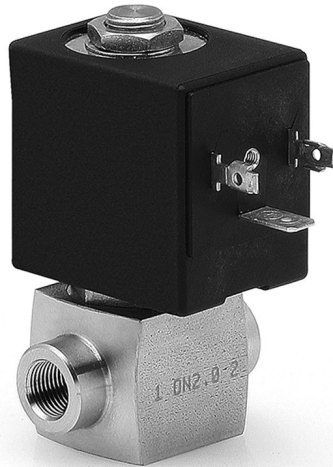

Series CFB Stainless Steel directly operated solenoid valves for general purpose, 2/2-way and 3/2-way NC, are the ideal solution for a wide range of applications whereby the environment and fluids used can be particularly aggressive and contaminating. Special versions are available on demand.

- » Stainless steel version for particularly aggressive environment and fluids
- » High reliability over time, even in hard working conditions
- » Compact dimensions
- » Suitable to control inert and medical gases, alimentary fluids and beverages

The valve function is determined by a poppet and the operation is direct. Different versions are available according to the nominal diameter and to the threaded ports, as shown in the following tables. They can thus satisfy various requirements in terms of flow rates and working pressures.

GENERAL DATA

TECHNICAL FEATURES

Function	2/2 NC - 3/2 NC
Operation	direct acting poppet type
Pneumatic connections	G1/8 ... G1/2 threads
Orifice diameter	1.5 ... 4 mm
Flow coefficient Kv (m ³ /h)	0.08 ... 0.28
Operating pressure	0 ÷ 4 ... 25 bar
Operating temperature	-10 ÷ 140 °C
Media	air, water, liquid and gaseous fluids with max viscosity 37 cSt (5° E)
Response time	ON <15 ms - OFF <25 ms
Installation	in any position

MATERIALS IN CONTACT WITH THE MEDIUM

Body	stainless steel 316L
Seals	FKM - EPDM
Internal parts	stainless steel

ELECTRICAL FEATURES

Voltage	12 V DC, 24 V DC - 24V AC 50 Hz, 110 V AC 50/60 Hz, 220/230 V AC 50/60 Hz
Voltage tolerance	±5% (DC) - ±10% (AC)
Power consumption	19 W (DC) - 15 VA (AC)
Duty cycle	ED 100%
Insulation class	H (180°C)
Electrical connection	DIN EN 175-301-803-A connector
Protection class	IP65 with connector

Special versions available on demand

It is recommended to use connections with internal diameters bigger than valve orifices, otherwise there may be a performance change.

CODING EXAMPLE

CFB	-	D	2	1	A	-	W	X	-	B8	E
------------	----------	----------	----------	----------	----------	----------	----------	----------	----------	-----------	----------

CFB	SERIES
D	OPERATION D = direct
2	NUMBER OF WAYS - POSITIONS 2 = 2/2-way - NC 3 = 3/2-way - NC
1	CONNECTIONS 1 = G1/8 2 = G1/4 3 = G3/8 4 = G1/2
A	ORIFICE DIAMETER A = 1.5 mm B = 2 mm C = 2.5 mm E = 3 mm F = 4 mm
W	SEALS MATERIAL W = FKM E = EPDM
X	BODY MATERIAL X = 316L stainless steel
B8	SOLENOID DIMENSION B8 = 30 mm
E	VOLTAGE - POWER CONSUMPTION B = 24 V 50/60 Hz - 15 VA D = 110 V 50/60 Hz - 15 VA E = 230 V 50/60 Hz - 15 VA 2 = 12 V DC - 19 W 3 = 24 V DC - 19 W

SERIES CFB STAINLESS STEEL SOLENOID VALVES

TABLE FOR THE COUPLING BETWEEN SOLENOIDS AND VALVES

For solenoids and their connectors see the dedicated section.
Coil mod. B8... - DIN EN 175 301-803-A = connector mod. 124-...

* = complete the code according to coding example

Mod.	24V AC 50 Hz	110V AC 50/60 Hz	220/230V AC 50/60 Hz	12V DC	24V DC
CFB-D21A -*	B8B (15VA)	B8D (15VA)	B8E (15VA)	B82 (19W)	B83 (19W)
CFB-D21B -*	B8B (15VA)	B8D (15VA)	B8E (15VA)	B82 (19W)	B83 (19W)
CFB-D21C -*	B8B (15VA)	B8D (15VA)	B8E (15VA)	B82 (19W)	B83 (19W)
CFB-D22B -*	B8B (15VA)	B8D (15VA)	B8E (15VA)	B82 (19W)	B83 (19W)
CFB-D22C -*	B8B (15VA)	B8D (15VA)	B8E (15VA)	B82 (19W)	B83 (19W)
CFB-D22E -*	B8B (15VA)	B8D (15VA)	B8E (15VA)	B82 (19W)	B83 (19W)
CFB-D23E -*	B8B (15VA)	B8D (15VA)	B8E (15VA)	B82 (19W)	B83 (19W)
CFB-D23F -*	B8B (15VA)	B8D (15VA)	B8E (15VA)	B82 (19W)	B83 (19W)
CFB-D24E -*	B8B (15VA)	B8D (15VA)	B8E (15VA)	B82 (19W)	B83 (19W)
CFB-D24F -*	B8B (15VA)	B8D (15VA)	B8E (15VA)	B82 (19W)	B83 (19W)
CFB-D32A -*	B8B (15VA)	B8D (15VA)	B8E (15VA)	B82 (19W)	B83 (19W)
CFB-D32B -*	B8B (15VA)	B8D (15VA)	B8E (15VA)	B82 (19W)	B83 (19W)
CFB-D32C -*	B8B (15VA)	B8D (15VA)	B8E (15VA)	B82 (19W)	B83 (19W)
CFB-D32E -*	B8B (15VA)	B8D (15VA)	B8E (15VA)	B82 (19W)	B83 (19W)

Series CFB solenoid valve - directly operated - 2/2 and 3/2 NC



The direct control of these solenoid valves allows to operate with working pressures that are equal to zero.

Ports: from G1/8 to G1/2.

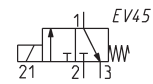
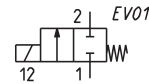

* add
 - SEALS MATERIAL
 - VOLTAGE
 (see CODING EXAMPLE)

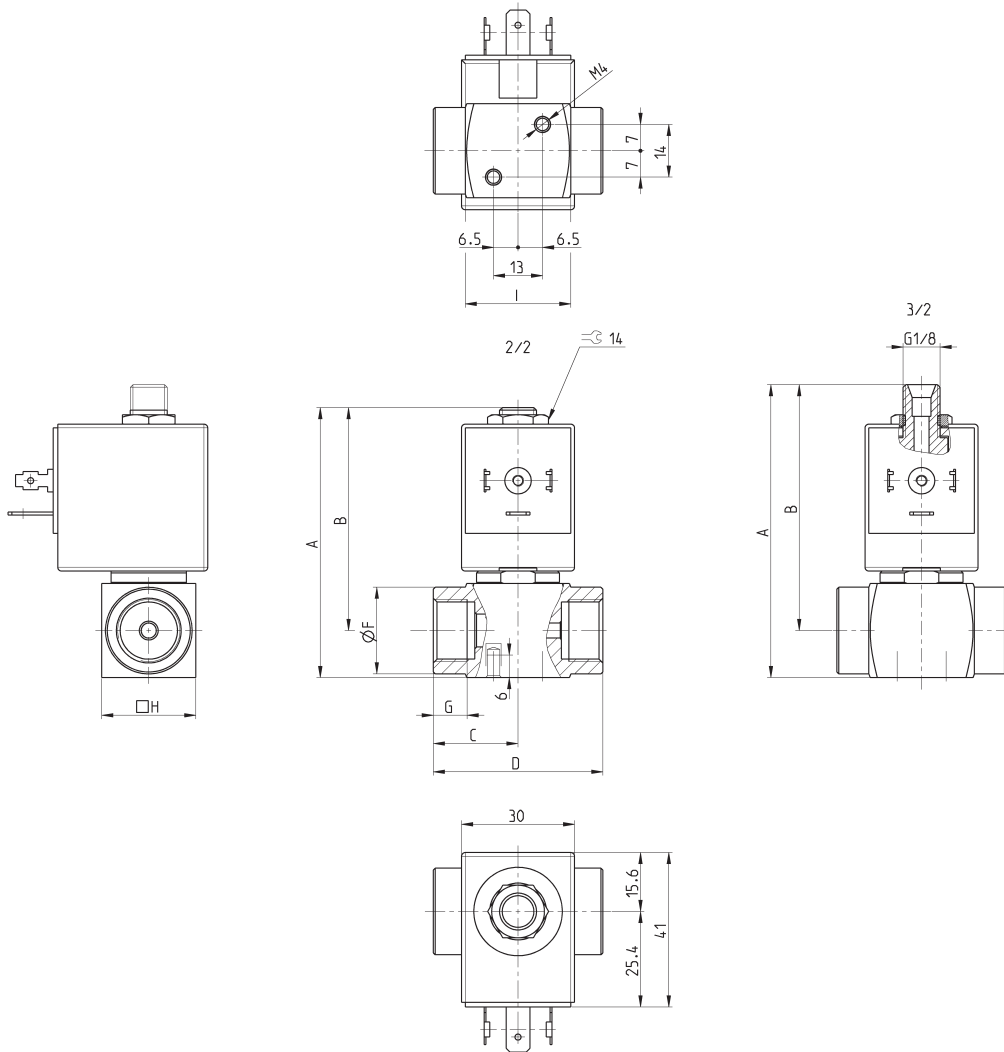

Mod.	Function	Connections	Orifice Ø (mm)	Kv (m³/h)	Pressure min-max (bar)	A	B	C	D	F	G	H	I	Pneumatic symbol
CFB-D21A-...X*	2/2 NC	G1/8	1.5	0.08	0 ÷ 25	71.7	59.2	21	42	15	8	25	29	EV01
CFB-D21B-...X*	2/2 NC	G1/8	2	0.10	0 ÷ 22	71.7	59.2	21	42	15	8	25	29	EV01
CFB-D21C-...X*	2/2 NC	G1/8	2.5	0.14	0 ÷ 15	71.7	59.2	21	42	15	8	25	29	EV01
CFB-D22B-...X*	2/2 NC	G1/4	2	0.10	0 ÷ 22	71.7	59.2	21	42	18	8	25	28	EV01
CFB-D22C-...X*	2/2 NC	G1/4	2.5	0.14	0 ÷ 15	71.7	59.2	21	42	18	8	25	28	EV01
CFB-D22E-...X*	2/2 NC	G1/4	3	0.18	0 ÷ 10	71.7	59.2	21	42	18	8	25	28	EV01
CFB-D23E-...X*	2/2 NC	G3/8	3	0.18	0 ÷ 10	71.7	59.2	22.5	45	23	9.5	25	28	EV01
CFB-D23F-...X*	2/2 NC	G3/8	4	0.28	0 ÷ 6	71.7	59.2	22.5	45	23	9.5	25	28	EV01
CFB-D24E-...X*	2/2 NC	G1/2	3	0.18	0 ÷ 10	76.7	61.7	24.5	49	27.5	11	30	31	EV01
CFB-D24F-...X*	2/2 NC	G1/2	4	0.28	0 ÷ 6	76.7	61.7	24.5	49	27.5	11	30	31	EV01
CFB-D32A-...X*	3/2 NC	G1/4	1.5	0.08	0 ÷ 13	77.8	65.3	21	42	18	8	25	28	EV45
CFB-D32B-...X*	3/2 NC	G1/4	2	0.1	0 ÷ 9	77.8	65.3	21	42	18	8	25	28	EV45
CFB-D32C-...X*	3/2 NC	G1/4	2.5	0.14	0 ÷ 5.5	77.8	65.3	21	42	18	8	25	28	EV45
CFB-D32E-...X*	3/2 NC	G1/4	3	0.18	0 ÷ 4	77.8	65.3	21	42	18	8	25	28	EV45

Series 8 pneumatic operated cartridge valves

2/2-way - Normally Closed (NC)
3/2-way - Normally Closed (NC)

SERIES 8 CARTRIDGE VALVES



Series 8 pneumatic operated valves are particularly suitable for applications requiring high flow combined with compact design. The valve is pneumatic operated by electro-pilots which are dimensioned according to the size. The cartridge design, which is ideal for manifold assembly, allows to reduce both dimensions and the number of pneumatic connections.

The standard function of the valve is 2/2-way NC. It can however fulfill the 3/2-way NC function if inserted in a proper seat (see the following pages).

- » New versions with PPS body
- » High flow
- » Manifold assembly
- » Oxygen use
- » Suitable also for general purpose

GENERAL DATA

TECHNICAL FEATURES

Function	2/2 NC - 3/2 NC
Operation	pneumatic operated poppet type
Pneumatic connections	cartridge seat in manifold
Orifice diameter	5 ... 9 mm
Nominal flow	420 ... 1480 Nl/min (air at 6 bar ΔP 1 bar)
Flow coefficient kv (l/min)	6.5 ... 23
Operating pressure	3 ÷ 6 bar (0 ÷ 6 bar with external pilot supply)
Piloting pressure	3 ÷ 6 bar
Operating temperature	0 ÷ 50 °C
Media	filtered air, class 5.4.4 according to ISO 8573-1 (max oil viscosity 32 cst), inert gas, oxygen
Installation	in any position

MATERIALS IN CONTACT WITH THE MEDIUM

Body	PPS - brass
Internal parts	aluminium
Seals	FKM

CODING EXAMPLE

8	10	C5	1	00	-	F1	3	2	-	OX2
8	SERIES									
10	SIZE 10 = size 1 - Ø 10.0 mm 20 = size 2 - Ø 14.5 mm 30 = size 3 - Ø 22.0 mm									
C5	BODY DESIGN C5 = cartridge									
1	NUMBER OF WAYS - FUNCTIONS 1 = 2/2 or 3/2-way - NC NOTE: the function 2/2 or 3/2-way depends on the seat used (see the following pages)									
00	PNEUMATIC CONNECTIONS 00 = cartridge									
F1	ORIFICE DIAMETER F1 = Ø 5.0 mm - size 1 only G7 = Ø 6.6 mm - size 2 only K1 = Ø 9.0 mm - size 3 only									
3	SEAL MATERIAL 3 = FKM									
2	BODY MATERIAL 2 = brass B = PPS									
OX2	OX2 = for use with oxygen (non volatile residual less than 33 mg/m ³) NOTE: the OX2 suffix must be added also in case of use with air/gas.									

Series 8 pneumatic cartridge valve - 2/2-way NC and 3/2-way NC

New



For 2/2-way (pneumatic symbol VP14) or 3/2-way (pneumatic symbol YES1) function, see the seat dimensioning in the next pages.

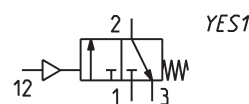
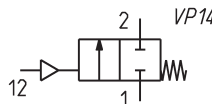
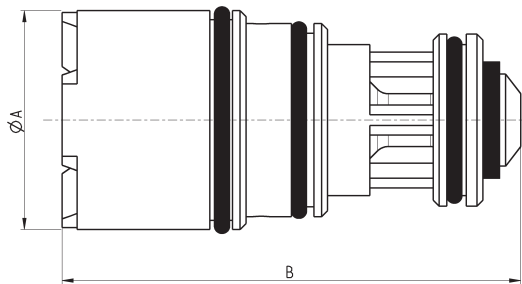

Mod.	Function	Orifice Ø (mm)	kv (l/min)	Min ÷ max pressure (bar)	Min ÷ max pilot pressure (bar)	Body material	A Ø (mm)	B (mm)
810C5100-F132-OX2	2/2 - 3/2 NC	5.0	6.5	0 ÷ 6	3 ÷ 6	brass	10	26.7
810C5100-G73B-OX2	2/2 - 3/2 NC	6.6	12.5	0 ÷ 6	3 ÷ 6	PPS	14.5	30.3
810C5100-G732-OX2	2/2 - 3/2 NC	6.6	12.5	0 ÷ 6	3 ÷ 6	brass	14.5	30.3
810C5100-K13B-OX2	2/2 - 3/2 NC	9.0	23	0 ÷ 6	3 ÷ 6	PPS	22	34.8
810C5100-K132-OX2	2/2 - 3/2 NC	9.0	23	0 ÷ 6	3 ÷ 6	brass	22	34.8

Series 8 pneumatic cartridge valve - 2/2-way NC - valve seat dimensions

1 = inlet
2 = outlet
12 = piloting
R = poppet chamber exhaust

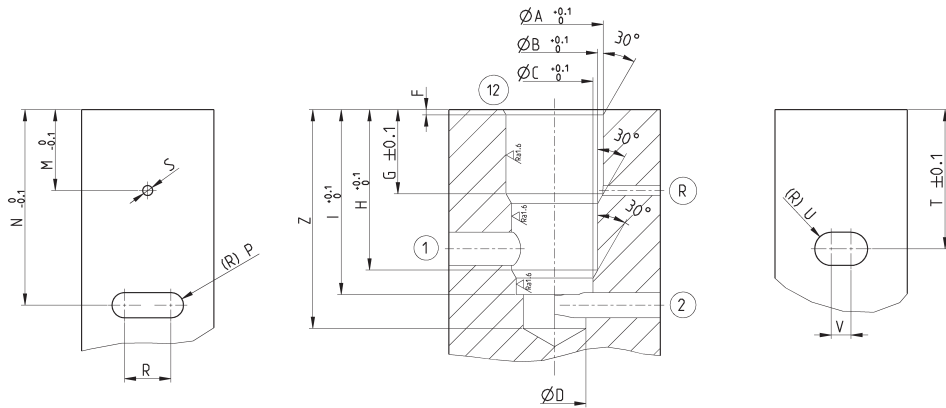

SERIES 8																	
Size	A	B	C	D	F	G	H	I	M	N	P	R	S	T	U	V	Z
1	10.4	9.7	9	8.2	0.8	14.5	20.7	25	13.2	26.2	1.5	5	1.5	19.1	1.5	5	30
2	14.65	12.95	11.55	9.5	0.8	12.8	24.2	27.9	12.2	29.3	1.9	7	1.5	20.5	2.5	4	33
3	22.1	20.6	19.6	16.2	0.5	15	28.7	33.4	12.5	37.1	4	4.4	2.5	24.8	3.75	5	41

Series 8 pneumatic cartridge valve - 3/2-way NC - valve seat dimensions

1 = inlet
2 = outlet
3 = exhaust
12 = piloting
R = poppet chamber exhaust

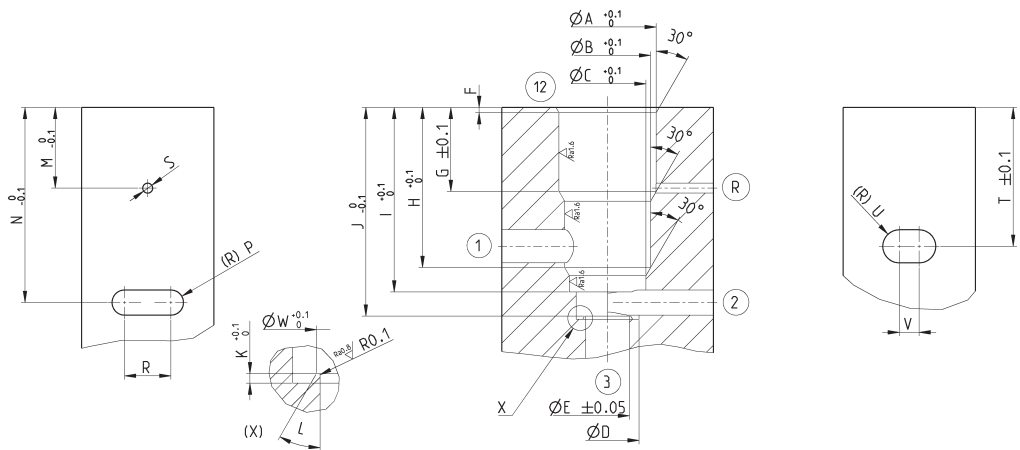

SERIES 8																					
Size	A	B	C	D	E	F	G	H	I	J	K	L	M	N	P	R	S	T	U	V	W
1	10.4	9.7	9	8.2	5	0.8	14.5	20.7	25	28	0.3	45	13.2	26.2	1.5	5	1.5	19.1	1.5	5	5.4
2	14.65	12.95	11.55	9.5	6.6	0.8	12.8	24.2	27.9	31.55	0.5	45	12.2	29.3	1.9	7	1.5	20.5	2.5	4	7
3	22.1	20.6	19.6	16.2	9	0.5	15	28.7	33.4	38.05	1	60	12.5	37.1	4	4.4	2.5	24.8	3.75	5	10

Series 8 pneumatically and electropneumatically operated valves

2/2-way - Normally Closed (NC)

3/2-way - Normally Closed (NC)

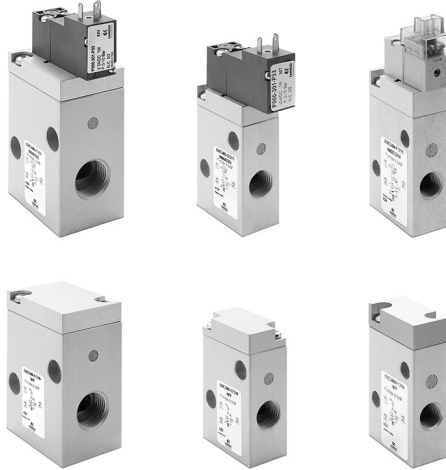

- » High flow
- » Available in 3 different sizes for general purpose
- » Version for use with oxygen available

The Series 8 enlarges the range of versions available with the cartridge valve directly integrated in an anodized aluminium body comprising also the pilot solenoid valve. The new bodies enable to have pneumatically operated versions with external piloting or electropneumatically operated versions with both external and internal piloting.

GENERAL DATA

TECHNICAL SPECIFICATIONS

Function	2/2 NC - 3/2 NC
Operation	pneumatic or electropneumatic
Pneumatic connections	G1/8 - G1/4 - G3/8
Nominal diameter	5 ... 9 mm
Flow coefficient kv (l/min)	6.5 ... 23
Nominal flow	420 ... 1480 Nl/min (air at 6 bar ΔP 1 bar)
Operating pressure	3 ÷ 6 bar (0 ÷ 6 bar with external pilot supply)
External pilot pressure	3 ÷ 6 bar
Operating temperature	0 ÷ 50 °C
Fluid	filtered air class 5.4.4 according to ISO 8573-1 (oil viscosity max. 32 cSt), inert gases
Response times	ON <10 ms - OFF <10 ms
Installation	any position

MATERIALS IN CONTACT WITH FLUID

Body	aluminium
Seals	FKM
Internal parts	aluminium - brass

ELECTRICAL SPECIFICATIONS

Voltage	24 V DC - other voltages on demand
Voltage tolerance	Size 1 = $\pm 10\%$ - Size 2 and 3 = -10% +15%
Power consumption	Size 1 = 1.3 W (inrush) 0.25 W (holding) - Size 2 and 3 = 2 W
Duty cycle	ED 100%
Electrical connection	connectors - 300 mm flying leads
Protection class	Size 1 = IP50 - Size 2 and 3 = IP65 (with connector)

CODING EXAMPLE

8	10	C3	4	04	-	F1	3	1	Y	-	N	00	2C	C014
----------	-----------	-----------	----------	-----------	----------	-----------	----------	----------	----------	----------	----------	-----------	-----------	-------------

8	SERIES
10	SIZE 10 = size 1 20 = size 2 30 = size 3
C3	TYPE OF BODY C3 = valve with aluminium body threaded connections
4	NUMBER OF WAYS - FUNCTIONS 1 = 2/2-way - NC 4 = 3/2-way - NC
04	PNEUMATIC CONNECTIONS 04 = G1/8 (size 1) 05 = G1/4 (size 2) 06 = G3/8 (size 3)
F1	ORIFICE DIAMETER F1 = 5.0 mm (size 1) G7 = 6.6 mm (size 2) K1 = 9.0 mm (size 3)
3	SEAL MATERIAL 3 = FKM
1	BODY MATERIAL 1 = aluminium
Y	MANUAL OVERRIDE N = not provided Y = provided monostable
N	MOUNTING ACCESSORIES N = not provided
00	OPTIONS 00 = no option PP = pneumatic piloting PE = electropilot with external piloting
2C	ELECTRICAL CONNECTION 2C = KN 90° type + protection + led - only for size 1 2F = KN in line type + protection + led - only for size 1 3A = DIN EN 175 301-803-C (8 mm) - only for size 2 and 3 4A = industrial standard (9.4 mm) - only for size 2 and 3 7A = 300 mm flying leads - only for size 2 and 3
C014	VOLTAGE - POWER CONSUMPTION C012 = 12V DC - 1.3/0.25W (size 1) C014 = 24V DC - 1.3/0.25W (size 1) C020 = 12V DC - 2W (size 2 - 3) C023 = 24V DC - 2W (size 2 - 3) C025 = 48V DC - 2W (size 2 - 3)
	VERSION = standard OX1 = for use with oxygen (non volatile residual less than 550 mg/m ²) OX2 = for use with oxygen (non volatile residual less than 33 mg/m ²)

SERIES 8 PNEUMATICALLY AND ELECTROPNEUMATICALLY OPERATED VALVES

Series 8 pneumatic valve - size 1 - 2/2 and 3/2-ways NC

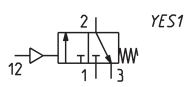
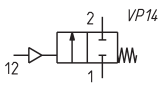
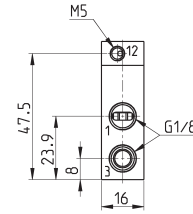
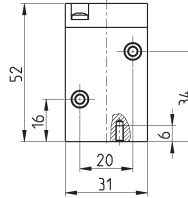
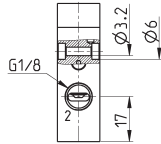
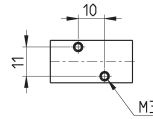

Mod.	Function	Ports	Orifice Ø (mm)	kv (l/min)	Qn (NL/min)	Min= max pressure (bar)	Min= max pilot pressure (bar)	Pilot supply	Symbol
810C3104-F131N-NPP	2/2 NC	G1/8	5.0	6.5	420	0 ÷ 6	3 ÷ 6	External	VP14
810C3404-F131N-NPP	3/2 NC	G1/8	5.0	6.5	420	0 ÷ 6	3 ÷ 6	External	YES1

Series 8 solenoid valve - size 1 - 2/2 and 3/2-ways NC

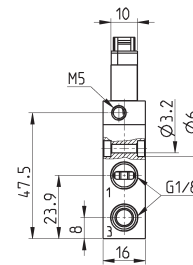
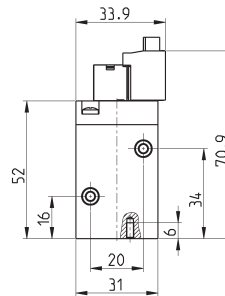
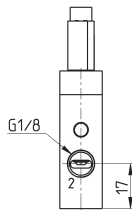
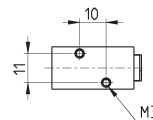

* add
- ELECTRICAL CONNECTION
- VOLTAGE
(see CODING EXAMPLE)

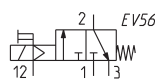
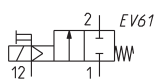
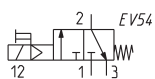
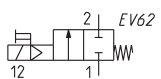

Mod.	Function	Ports	Orifice Ø (mm)	kv (l/min)	Qn (NL/min)	Min= max pressure (bar)	Min= max pilot pressure (bar)	Pilot supply	Symbol
810C3104-F131Y-N00*	2/2 NC	G1/8	5.0	6.5	420	3 ÷ 6	-	Internal	EV62
810C3404-F131Y-N00*	3/2 NC	G1/8	5.0	6.5	420	3 ÷ 6	-	Internal	EV54
810C3104-F131Y-NPE*	2/2 NC	G1/8	5.0	6.5	420	0 ÷ 6	3 ÷ 6	External	EV61
810C3404-F131Y-NPE*	3/2 NC	G1/8	5.0	6.5	420	0 ÷ 6	3 ÷ 6	External	EV56

Series 8 pneumatic valve - size 2 - 2/2 and 3/2-ways NC

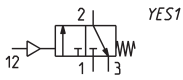
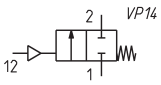
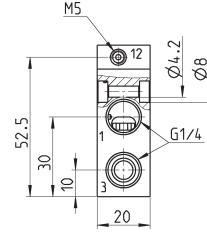
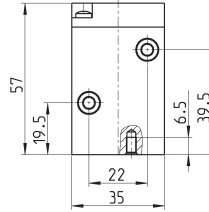
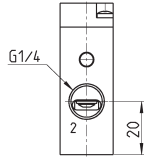
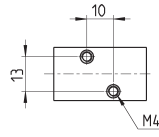

Mod.	Function	Ports	Orifice \varnothing (mm)	kv (l/min)	Qn (Nl/min)	Min+max pressure (bar)	Min+max pilot pressure (bar)	Pilot supply	Symbol
820C3105-G731N-NPP	2/2 NC	G1/4	6.6	12.5	800	0 ÷ 6	3 ÷ 6	External	VP14
820C3405-G731N-NPP	3/2 NC	G1/4	6.6	12.5	800	0 ÷ 6	3 ÷ 6	External	YES1

Series 8 solenoid valve - size 2 - 2/2 and 3/2-ways NC



* add
- ELECTRICAL CONNECTION
- VOLTAGE
(see CODING EXAMPLE)

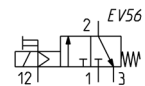
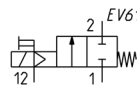
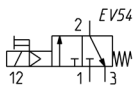
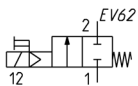
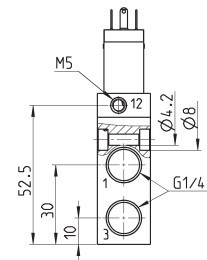
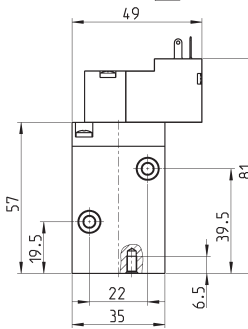
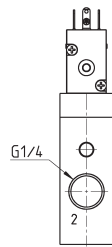
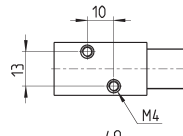

Mod.	Function	Ports	Orifice \varnothing (mm)	kv (l/min)	Qn (Nl/min)	Min+max pressure (bar)	Min+max pilot pressure (bar)	Pilot supply	Symbol
820C3105-G731Y-N00*	2/2 NC	G1/4	6.6	12.5	800	3 ÷ 6	-	Internal	EV62
820C3405-G731Y-N00*	3/2 NC	G1/4	6.6	12.5	800	3 ÷ 6	-	Internal	EV54
820C3105-G731Y-NPE*	2/2 NC	G1/4	6.6	12.5	800	0 ÷ 6	3 ÷ 6	External	EV61
820C3405-G731Y-NPE*	3/2 NC	G1/4	6.6	12.5	800	0 ÷ 6	3 ÷ 6	External	EV56

Series TC shut-off micro-valves

2/2-way - Normally Closed (NC)

SERIES TC SHUT-OFF MICRO-VALVES



- » Compact design
- » High performance
- » Ease of installation
- » Compatibility between materials used and several gaseous fluids
- » Suitable for applications with oxygen

The principle of the Series TC1-V shut-off micro-valves is based on the actuation of a poppet by means of an operating pressure applied above it.

The poppet, once actuated, moves away from the tightening seal, permitting the flow of the intercepted fluid.

By removing the actuation pressure, the poppet repositions itself on the tightening seal by means of a spring positioned below that closes the flow of the fluid.

For its realization the most suitable materials for contact with fluids were selected. The body in PPS and the FKM tightening seals guarantee full compatibility with a wide range of gaseous fluids.

GENERAL DATA

Construction	compact with pre-formed diaphragm
Materials	see the TABLE OF MATERIALS
Ports	cartridge construction in manifold - G1/8 or 1/8NPTF (only for aluminium body version)
Mounting	in-line or cartridge (any position)
Operating temperature	-5°C ÷ 50°C
Inlet pressure	0 ÷ 10 bar
Pilot pressure	0.6 ÷ 10 bar
Nominal flow	240 Nl/min (6 bar ΔP 1 bar)
Medium	air, inert/medical gases and oxygen

CODING EXAMPLE

TC	1	-	V	36	-	C	-	V	-	OX2
-----------	----------	----------	----------	-----------	----------	----------	----------	----------	----------	------------

TC	SERIES
1	SIZE
V	VALVE
36	CONSTRUCTION: 36 = pneumatic command
C	PORTS: C = Cartridge 1/8 = G1/8 1/8TF = 1/8NPTF
V	SEALS MATERIAL: V = FKM
OX2	VERSIONS: OX1 = for oxygen (non-volatile residue lower than 550 mg/m ²) OX2 = for oxygen (non-volatile residue lower than 33 mg/m ²)

SERIES TC SHUT-OFF MICRO-VALVES

Series TC shut-off micro-valves - materials

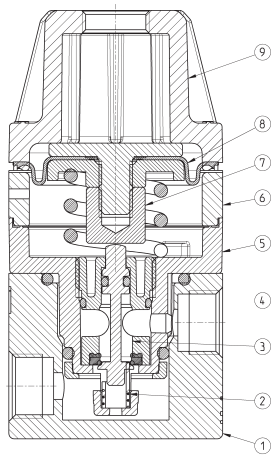

PARTS	MATERIALS
1. Base body	Anodized aluminium
2. Lower spring	Stainless steel
3. Insert	PPS
4. Poppet	Stainless steel
5. Body	PPS
6 Intermediate body	Anodized aluminium
7. Valve guide	Polyamide
8. Diaphragm	FKM
9. Bell	Polyamide
Seals	FKM

Series TC cartridge shut-off micro-valves

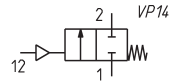
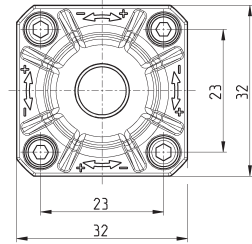
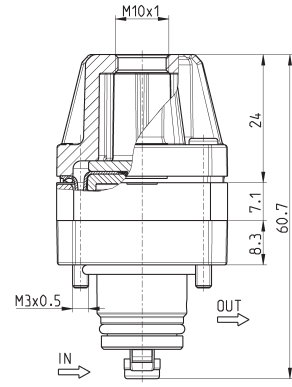

Mod.
TC1-V36-C-V-OX1
TC1-V36-C-V-OX2

Series TC shut-off micro-valves with aluminium body



* to choose the type of thread (G1/8 or 1/8 NPTF)
see the Coding example

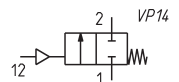
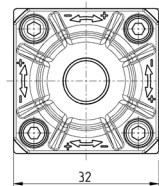
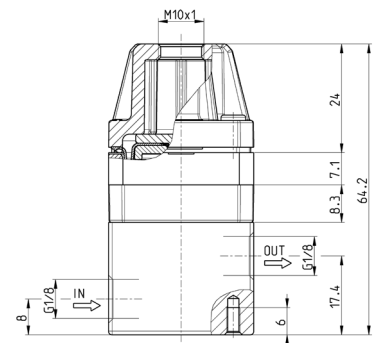
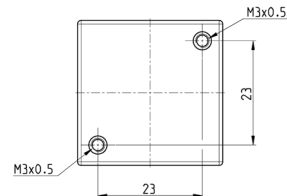

Mod.
TC1-V36-1/8-V-OX1
TC1-V36-1/8-V-OX2

Seat dimensions for Series TC cartridge valve

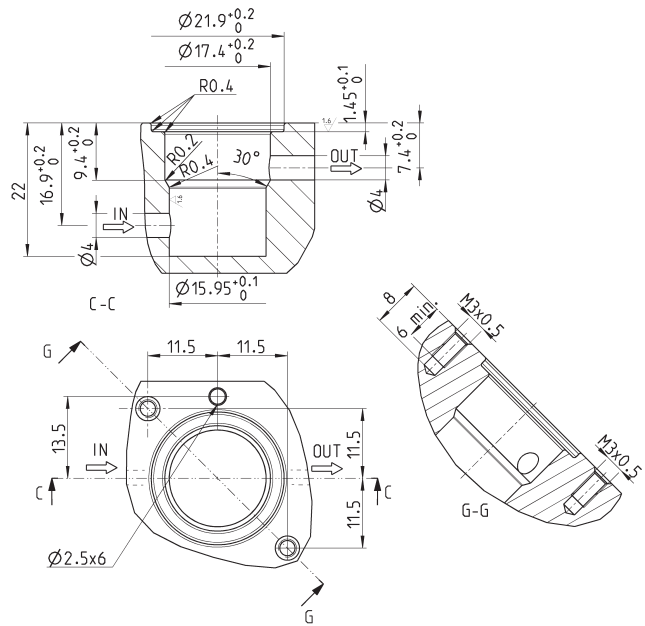

SERIES TC SHUT-OFF MICRO-VALVES

New

Series ASX angle seat valves

2/2-way - Normally Closed (NC) and Normally Open (NO)
2/2-way - Double Acting (DA)

SERIES ASX ANGLE SEAT VALVES



- » High flow
- » Low resistance of the flow
- » Anti-water hammer design
- » Compliant with Directive PED 2014/68/UE
- » Compliant with Directive ATEX for Zones 1/21 - II 2G Ex h IIC T4 Gb and II 2D Ex h IIC T135 °C Db -10 ≤ Ta ≤ +80 °C

Angle seat valves are available in different versions with regard to nominal diameter, type of fluid and process connections. They are able to manage media that are corrosive or contain suspended solid particulate matter and can be used in applications with high operating temperatures.

The operation is determined by the pneumatic drive of a single acting, guided piston actuator with spring return. There are also models available with double acting actuators, without spring. For liquid media we recommend the models with flow direction under the seat. For gas or steam we recommend the models with flow direction above the seat.

GENERAL DATA

TECHNICAL FEATURES

Function	2/2 NC - 2/2 NO - 2/2 Double Acting
Operation	pneumatic, poppet type
Pneumatic connections	1/4 ... 4" with BSP/BSPT/NPT threads, flanged, welding ends, tri-clamp
Nominal diameter	DN8 ... DN100
Flow coefficient Kv (m ³ /h)	2.2 ... 132
Operating pressure	0 ÷ 2 ... 16 bar
Operating temperature	-10 ÷ 180 °C (standard seals) / 25 ÷ 220 °C (high temperature seals)
Media	water, air, steam, inert or corrosive liquids and gases (compatible with the materials in contact)
Viscosity	600 cSt. max
Installation	in any position

MATERIALS IN CONTACT WITH THE MEDIUM

Body	316 stainless steel (DN8 ÷ DN80) / 304 stainless steel (DN100)
Seals	PTFE
Internal parts	316 stainless steel

SPECIFICATIONS PNEUMATIC ACTUATOR

Actuator dimensions	Ø40 - Ø50 - Ø63 - Ø90 - Ø125 mm
Actuator material	304 stainless steel / aluminium (only for Ø125 mm)
Piston material	aluminium
Piston seal material	FKM
Piloting fluid	air or inert gases
Piloting pressure	10 bar max.
Actuator position	360° rotatable

CODING EXAMPLE

AS	X	2	1	-	W	015	G1	-	040	1	2	-	
-----------	----------	----------	----------	----------	----------	------------	-----------	----------	------------	----------	----------	----------	--

AS	SERIES
X	TYPE OF ACTUATOR X = metal actuator
2	BODY MATERIAL 1 = 304 stainless steel (DN 100) 2 = 316 stainless steel (DN8 ÷ DN80)
1	NUMBER OF WAYS - FUNCTIONS 0 = 2/2-way NO 1 = 2/2-way NC 3 = 2/2-way DA (Double Acting)
W	FLOW DIRECTION W = under the seat (anti-water hammer) Y = above the seat
015	NOMINAL DIAMETER 008 = DN 8 010 = DN 10 015 = DN 15 020 = DN 20 025 = DN 25 032 = DN 32 040 = DN 40 050 = DN 50 065 = DN 65 080 = DN 80 100 = DN 100 - only for flanged version with NC and DA function and pressure under the seat
G1	BODY CONNECTION G1 = BSP thread DIN 228-1 T1 = BSPT thread DIN 2999-1 N1 = NPT thread ASME B1.20.1 H7 = welding ends DIN 11850-2 / DIN 11866-A H8 = welding ends DIN 11850-3 K7 = tri-clamp ISO 2852 F2 = flange DIN 2543
040	ACTUATOR DIMENSION 040 = Ø40 mm 050 = Ø50 mm 063 = Ø63 mm 090 = Ø90 mm 125 = Ø125 mm
1	ACTUATOR MATERIAL 1 = 304 stainless steel 8 = aluminium
2	SEALS 2 = for standard temperatures -10 ÷ 180 °C 3 = for high temperatures 25 ÷ 220 °C
	<p>OPTIONS</p> <p>= none</p> <p>PS1 = NPN type proximity switch - NO contact - 10 ÷ 30 V DC power supply</p> <p>PS2 = NPN type proximity switch - NC contact - 10 ÷ 30 V DC power supply</p> <p>PS3 = PNP type proximity switch - NO contact - 10 ÷ 30 V DC power supply</p> <p>PS4 = NPN type proximity switch - NC contact - 10 ÷ 30 V DC power supply</p> <p>PS5 = SCR type proximity switch - NO contact - 20 ÷ 250 V AC power supply</p> <p>PS6 = SCR type proximity switch - NC contact - 20 ÷ 250 V AC power supply</p> <p>SL1 = stroke limiter for Ø50 - Ø63 mm actuators</p> <p>SL2 = stroke limiter for Ø90 mm actuators</p> <p>PI1 = position indicator for Ø40 - Ø50 - Ø63 - Ø90 mm actuators</p> <p>PI2 = position indicator for Ø125 mm actuators</p>

Series ASX angle seat valve - 2/2-way NC - pressure under the seat



The valves with flow direction under the seat are suitable for incompressible fluids. This function prevents the hydraulic water hammer effect.

NOTE TO THE TABLE:

The indicated models are suitable for operating temperatures from -10 to +180 °C. For higher temperatures, please see the CODING EXAMPLE.
* to complete the code add BODY CONNECTION.

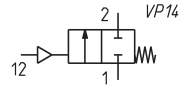

DRAWING LEGEND:
C = valve in closed position
O = valve in open position

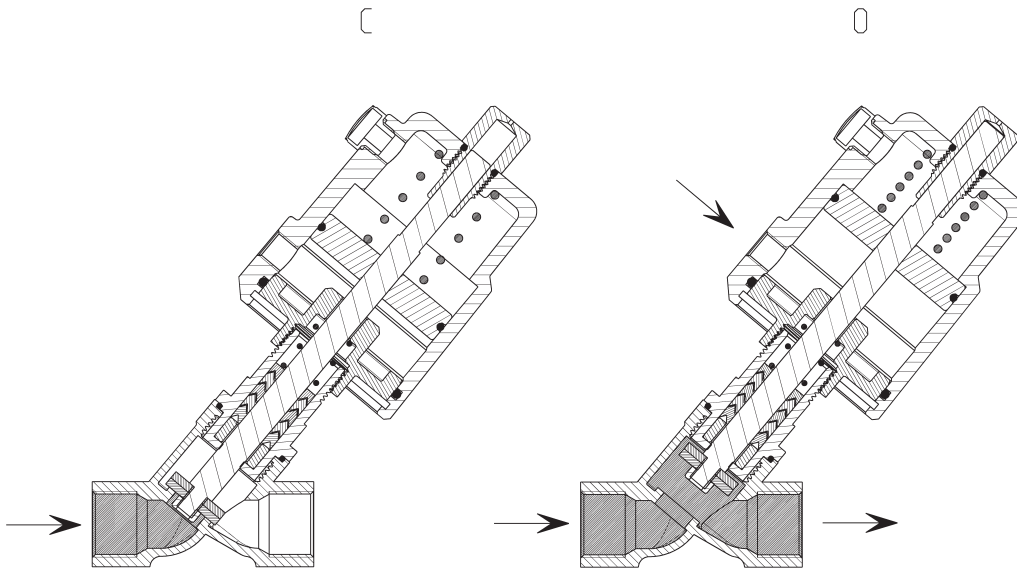

DIMENSIONS									
Mod.	Function	DN	Ports	Orifice Ø (mm)	Kv (m³/h)	Differential pressure min ÷ max (bar)	Minimum piloting pressure (bar)	Actuator Ø (mm)	Actuator material
ASX21-W008 ² -04012	2/2 NC	8	1/4"	13	2.2	0 ÷ 13	≥ 4	40	304 stainless steel
ASX21-W008 ² -05012	2/2 NC	8	1/4"	13	2.2	0 ÷ 14	≥ 4.5	50	304 stainless steel
ASX21-W010 ² -04012	2/2 NC	10	3/8"	13	3.9	0 ÷ 13	≥ 4	40	304 stainless steel
ASX21-W010 ² -05012	2/2 NC	10	3/8"	13	3.9	0 ÷ 14	≥ 4.5	50	304 stainless steel
ASX21-W015 ² -04012	2/2 NC	15	1/2"	13	4.3	0 ÷ 13	≥ 4	40	304 stainless steel
ASX21-W015 ² -05012	2/2 NC	15	1/2"	13	4.3	0 ÷ 14	≥ 4.5	50	304 stainless steel
ASX21-W020 ² -05012	2/2 NC	20	3/4"	18	7.6	0 ÷ 14	≥ 4.5	50	304 stainless steel
ASX21-W025 ² -05012	2/2 NC	25	1"	24	15.8	0 ÷ 8	≥ 4.5	50	304 stainless steel
ASX21-W025 ² -06312	2/2 NC	25	1"	24	15.8	0 ÷ 13	≥ 5	63	304 stainless steel
ASX21-W032 ² -06312	2/2 NC	32	1 1/4"	31	26	0 ÷ 6	≥ 5	63	304 stainless steel
ASX21-W032 ² -09012	2/2 NC	32	1 1/4"	31	26	0 ÷ 16	≥ 6	90	304 stainless steel
ASX21-W040 ² -06312	2/2 NC	40	1 1/2"	35	32	0 ÷ 5	≥ 5	63	304 stainless steel
ASX21-W040 ² -09012	2/2 NC	40	1 1/2"	35	32	0 ÷ 16	≥ 6	90	304 stainless steel
ASX21-W050 ² -06312	2/2 NC	50	2"	45	52	0 ÷ 5	≥ 5	63	304 stainless steel
ASX21-W050 ² -09012	2/2 NC	50	2"	45	52	0 ÷ 10	≥ 6	90	304 stainless steel
ASX21-W050 ² -12582	2/2 NC	50	2"	45	52	0 ÷ 16	≥ 5.5	125	aluminium
ASX21-W065 ² -09012	2/2 NC	65	2 1/2"	61	83.2	0 ÷ 5	≥ 6	90	304 stainless steel
ASX21-W065 ² -12582	2/2 NC	65	2 1/2"	61	83.2	0 ÷ 9	≥ 5.5	125	aluminium
ASX21-W080 ² -12582	2/2 NC	80	3"	80	119	0 ÷ 5	≥ 5.5	125	aluminium
ASX11-W100F2-12582	2/2 NC	100	4"	90	132	0 ÷ 2.5	≥ 5.5	125	aluminium

Series ASX angle seat valve - 2/2-way NC - pressure above the seat



The valves with flow direction above the seat are suitable for compressible fluids.

NOTE TO THE TABLE:
The indicated models are suitable for operating temperatures from -10 to +180 °C. For higher temperatures, please see the CODING EXAMPLE.
* to complete the code add BODY CONNECTION.

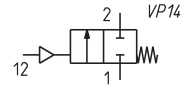

DRAWING LEGEND:
C = valve in closed position
O = valve in open position

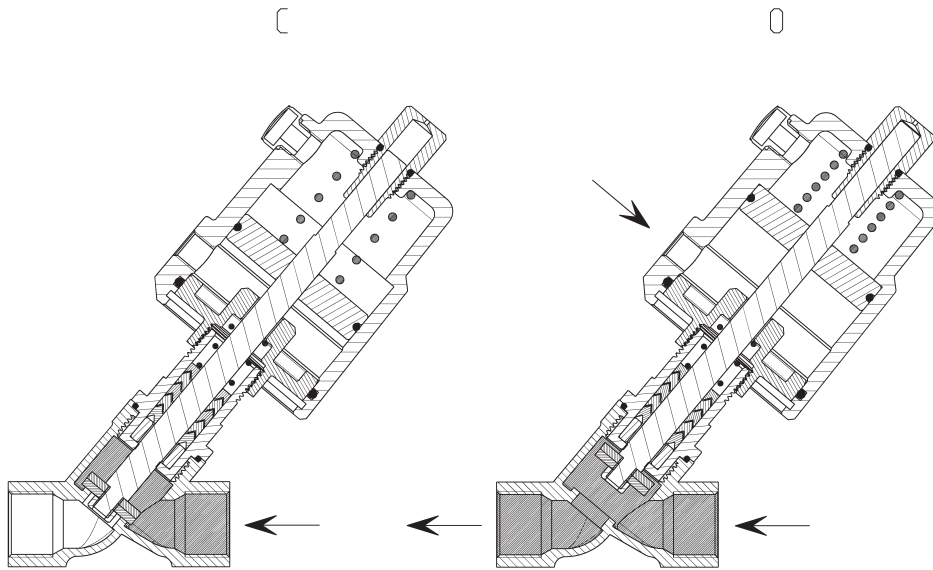

DIMENSIONS									
Mod.	Function	DN	Ports	Orifice Ø (mm)	Kv (m³/h)	Differential pressure min ÷ max (bar)	Minimum piloting pressure (bar)	Actuator Ø (mm)	Actuator material
ASX21-Y008*-04012	2/2 NC	8	1/4"	13	2.2	0 ÷ 16	3 ÷ 4.5	40	304 stainless steel
ASX21-Y008*-05012	2/2 NC	8	1/4"	13	2.2	0 ÷ 16	3 ÷ 3.5	50	304 stainless steel
ASX21-Y010*-04012	2/2 NC	10	3/8"	13	3.9	0 ÷ 16	3 ÷ 4.5	40	304 stainless steel
ASX21-Y010*-05012	2/2 NC	10	3/8"	13	3.9	0 ÷ 16	3 ÷ 3.5	50	304 stainless steel
ASX21-Y015*-04012	2/2 NC	15	1/2"	13	4.3	0 ÷ 16	3 ÷ 4.5	40	304 stainless steel
ASX21-Y015*-05012	2/2 NC	15	1/2"	13	4.3	0 ÷ 16	3 ÷ 3.5	50	304 stainless steel
ASX21-Y020*-05012	2/2 NC	20	3/4"	18	7.6	0 ÷ 16	3 ÷ 4	50	304 stainless steel
ASX21-Y025*-05012	2/2 NC	25	1"	24	15.8	0 ÷ 16	3 ÷ 4.5	50	304 stainless steel
ASX21-Y025*-06312	2/2 NC	25	1"	24	15.8	0 ÷ 16	3 ÷ 3.5	63	304 stainless steel
ASX21-Y032*-06312	2/2 NC	32	1 1/4"	31	26	0 ÷ 16	3 ÷ 5.5	63	304 stainless steel
ASX21-Y032*-09012	2/2 NC	32	1 1/4"	31	26	0 ÷ 16	3 ÷ 3.5	90	304 stainless steel
ASX21-Y040*-06312	2/2 NC	40	1 1/2"	35	32	0 ÷ 16	3 ÷ 6.5	63	304 stainless steel
ASX21-Y040*-09012	2/2 NC	40	1 1/2"	35	32	0 ÷ 16	3 ÷ 4	90	304 stainless steel
ASX21-Y050*-06312	2/2 NC	50	2"	45	52	0 ÷ 9	3 ÷ 7	63	304 stainless steel
ASX21-Y050*-09012	2/2 NC	50	2"	45	52	0 ÷ 16	3 ÷ 4.5	90	304 stainless steel
ASX21-Y050*-12582	2/2 NC	50	2"	45	52	0 ÷ 16	3 ÷ 4	125	aluminium
ASX21-Y065*-09012	2/2 NC	65	2 1/2"	61	83.2	0 ÷ 10	3 ÷ 6	90	304 stainless steel
ASX21-Y065*-12582	2/2 NC	65	2 1/2"	61	83.2	0 ÷ 16	3 ÷ 4	125	aluminium
ASX21-Y080*-12582	2/2 NC	80	3"	80	119	0 ÷ 12	3 ÷ 7	125	aluminium

Series ASX angle seat valve - 2/2-way NO - pressure under the seat



The valves with flow direction under the seat are suitable for incompressible fluids. This function prevents the hydraulic water hammer effect.

NOTE TO THE TABLE:

The indicated models are suitable for operating temperatures from -10 to +180 °C. For higher temperatures, please see the CODING EXAMPLE.
* to complete the code add BODY CONNECTION.

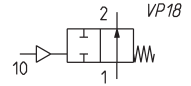

DRAWING LEGEND:
C = valve in closed position
O = valve in open position

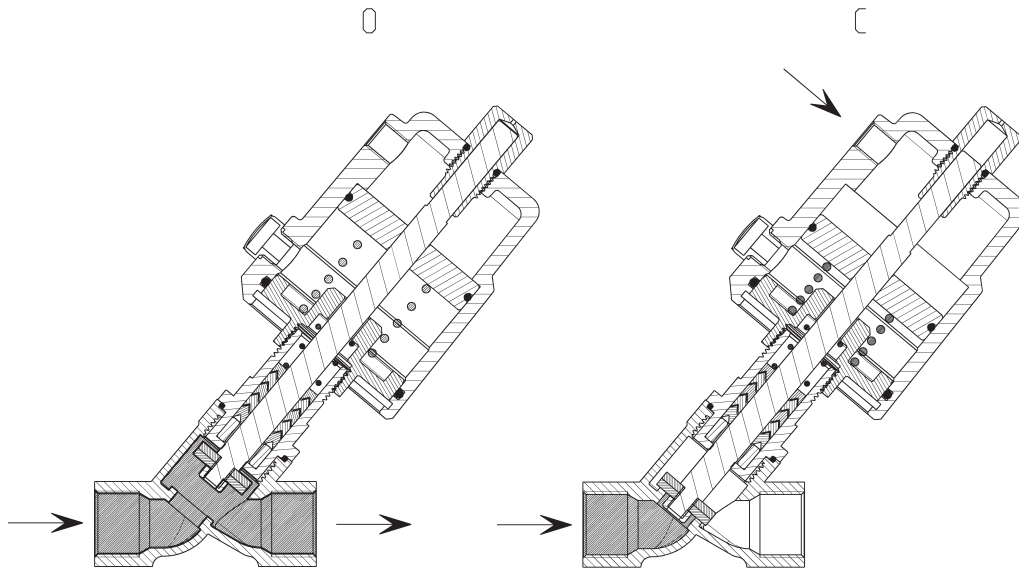

DIMENSIONS									
Mod.	Function	DN	Ports	Orifice Ø (mm)	Kv (m ³ /h)	Differential pressure min ÷ max (bar)	Minimum piloting pressure (bar)	Actuator Ø (mm)	Actuator material
ASX20-W008 ² -04012	2/2 NO	8	1/4"	13	2.2	0 ÷ 16	3 ÷ 5	40	304 stainless steel
ASX20-W008 ² -05012	2/2 NO	8	1/4"	13	2.2	0 ÷ 16	3 ÷ 4	50	304 stainless steel
ASX20-W010 ² -04012	2/2 NO	10	3/8"	13	3.9	0 ÷ 16	3 ÷ 5	40	304 stainless steel
ASX20-W010 ² -05012	2/2 NO	10	3/8"	13	3.9	0 ÷ 16	3 ÷ 4	50	304 stainless steel
ASX20-W015 ² -04012	2/2 NO	15	1/2"	13	4.3	0 ÷ 16	3 ÷ 5	40	304 stainless steel
ASX20-W015 ² -05012	2/2 NO	15	1/2"	13	4.3	0 ÷ 16	3 ÷ 4	50	304 stainless steel
ASX20-W020 ² -05012	2/2 NO	20	3/4"	18	7.6	0 ÷ 16	3 ÷ 6	50	304 stainless steel
ASX20-W025 ² -05012	2/2 NO	25	1"	24	15.8	0 ÷ 13	3 ÷ 6	50	304 stainless steel
ASX20-W025 ² -06312	2/2 NO	25	1"	24	15.8	0 ÷ 16	3 ÷ 5	63	304 stainless steel
ASX20-W032 ² -06312	2/2 NO	32	1 1/4"	31	26	0 ÷ 13	3 ÷ 6	63	304 stainless steel
ASX20-W040 ² -06312	2/2 NO	40	1 1/2"	35	32	0 ÷ 7	3 ÷ 6	63	304 stainless steel
ASX20-W040 ² -09012	2/2 NO	40	1 1/2"	35	32	0 ÷ 16	3 ÷ 3.5	90	304 stainless steel
ASX20-W050 ² -06312	2/2 NO	50	2"	45	52	0 ÷ 5	3 ÷ 6	63	304 stainless steel
ASX20-W050 ² -09012	2/2 NO	50	2"	45	52	0 ÷ 12	3 ÷ 6	90	304 stainless steel
ASX20-W065 ² -09012	2/2 NO	65	2 1/2"	61	83.2	0 ÷ 7.5	3 ÷ 5	90	304 stainless steel
ASX20-W065 ² -12582	2/2 NO	65	2 1/2"	61	83.2	0 ÷ 14	3 ÷ 7	125	aluminium
ASX20-W080 ² -12582	2/2 NO	80	3"	80	119	0 ÷ 12	3 ÷ 7	125	aluminium

Series ASX angle seat valve - 2/2-way NO - pressure above the seat



The valves with flow direction above the seat are suitable for compressible fluids.

NOTE TO THE TABLE:
 The indicated models are suitable for operating temperatures from -10 to +180 °C. For higher temperatures, please see the CODING EXAMPLE.
 * to complete the code add BODY CONNECTION.

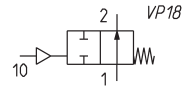

DRAWING LEGEND:
 C = valve in closed position
 O = valve in open position

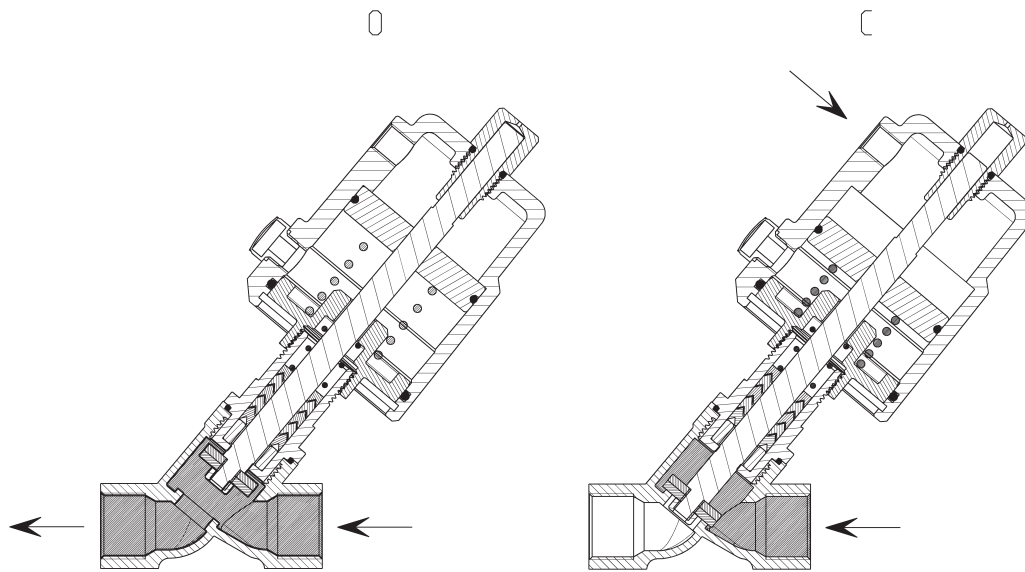

DIMENSIONS									
Mod.	Function	DN	Ports	Orifice Ø (mm)	Kv (m³/h)	Differential pressure min ÷ max (bar)	Minimum piloting pressure (bar)	Actuator Ø (mm)	Actuator material
ASX20-Y008*-04012	2/2 NO	8	1/4"	13	2.2	0 ÷ 16	≥ 3	40	304 stainless steel
ASX20-Y008*-05012	2/2 NO	8	1/4"	13	2.2	0 ÷ 16	≥ 3	50	304 stainless steel
ASX20-Y010*-04012	2/2 NO	10	3/8"	13	3.9	0 ÷ 16	≥ 3	40	304 stainless steel
ASX20-Y010*-05012	2/2 NO	10	3/8"	13	3.9	0 ÷ 16	≥ 3	50	304 stainless steel
ASX20-Y015*-04012	2/2 NO	15	1/2"	13	4.3	0 ÷ 16	≥ 3	40	304 stainless steel
ASX20-Y015*-05012	2/2 NO	15	1/2"	13	4.3	0 ÷ 16	≥ 3	50	304 stainless steel
ASX20-Y020*-05012	2/2 NO	20	3/4"	18	7.6	0 ÷ 12	≥ 3	50	304 stainless steel
ASX20-Y025*-05012	2/2 NO	25	1"	24	15.8	0 ÷ 3	≥ 3	50	304 stainless steel
ASX20-Y025*-06312	2/2 NO	25	1"	24	15.8	0 ÷ 16	≥ 4.5	63	304 stainless steel
ASX20-Y032*-06312	2/2 NO	32	1 1/4"	31	26	0 ÷ 14	≥ 4.5	63	304 stainless steel
ASX20-Y040*-06312	2/2 NO	40	1 1/2"	35	32	0 ÷ 14	≥ 4.5	63	304 stainless steel
ASX20-Y050*-06312	2/2 NO	50	2"	45	52	0 ÷ 6	≥ 4.5	63	304 stainless steel

Series ASX angle seat valve - 2/2-way DA - pressure under the seat



The valves with flow direction under the seat are suitable for incompressible fluids. This function prevents the hydraulic water hammer effect.

NOTE TO THE TABLE:

The indicated models are suitable for operating temperatures from -10 to +180 °C. For higher temperatures, please see the CODING EXAMPLE.
* to complete the code add BODY CONNECTION.

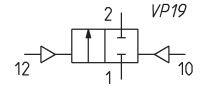

DRAWING LEGEND:
C = valve in closed position
O = valve in open position

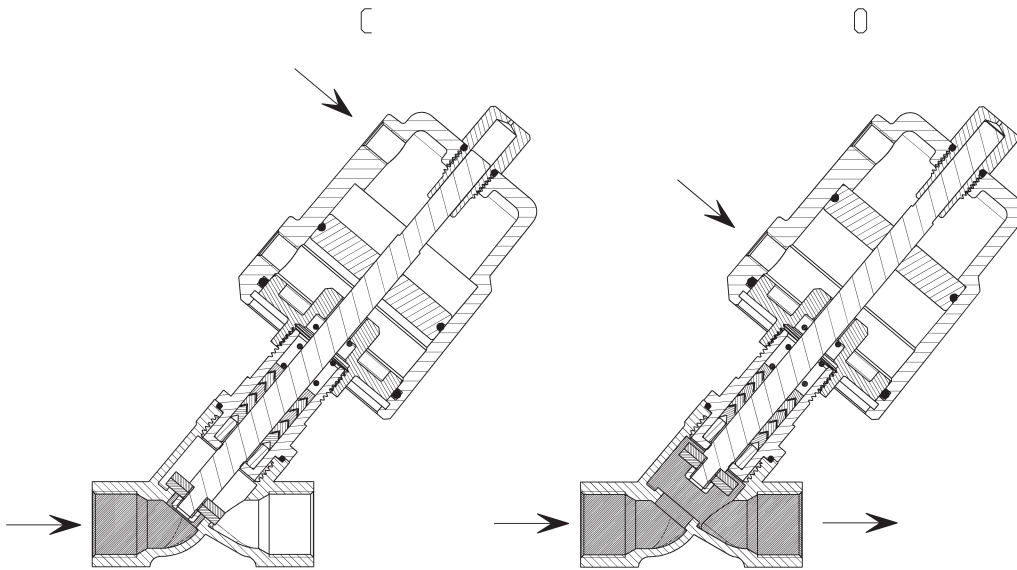

DIMENSIONS									
Mod.	Function	DN	Ports	Orifice Ø (mm)	Kv (m³/h)	Differential pressure min ÷ max (bar)	Minimum piloting pressure (bar)	Actuator Ø (mm)	Actuator material
ASX23-W008 ² -04012	2/2 DA	8	1/4"	13	2.2	0 ÷ 16	3 ÷ 4	40	304 stainless steel
ASX23-W008 ² -05012	2/2 DA	8	1/4"	13	2.2	0 ÷ 16	3 ÷ 4	50	304 stainless steel
ASX23-W010 ² -04012	2/2 DA	10	3/8"	13	3.9	0 ÷ 16	3 ÷ 4	40	304 stainless steel
ASX23-W010 ² -05012	2/2 DA	10	3/8"	13	3.9	0 ÷ 16	3 ÷ 4	50	304 stainless steel
ASX23-W015 ² -04012	2/2 DA	15	1/2"	13	4.3	0 ÷ 16	3 ÷ 4	40	304 stainless steel
ASX23-W015 ² -05012	2/2 DA	15	1/2"	13	4.3	0 ÷ 16	3 ÷ 4	50	304 stainless steel
ASX23-W020 ² -05012	2/2 DA	20	3/4"	18	7.6	0 ÷ 16	3 ÷ 4	50	304 stainless steel
ASX23-W025 ² -05012	2/2 DA	25	1"	24	15.8	0 ÷ 16	3 ÷ 6.5	50	304 stainless steel
ASX23-W025 ² -06312	2/2 DA	25	1"	24	15.8	0 ÷ 16	3 ÷ 5.5	63	304 stainless steel
ASX23-W032 ² -06312	2/2 DA	32	1 1/4"	31	26	0 ÷ 16	3 ÷ 7	63	304 stainless steel
ASX23-W032 ² -09012	2/2 DA	32	1 1/4"	31	26	0 ÷ 16	3 ÷ 4.5	90	304 stainless steel
ASX23-W040 ² -06312	2/2 DA	40	1 1/2"	35	32	0 ÷ 12	3 ÷ 7.5	63	304 stainless steel
ASX23-W040 ² -09012	2/2 DA	40	1 1/2"	35	32	0 ÷ 16	3 ÷ 5	90	304 stainless steel
ASX23-W050 ² -06312	2/2 DA	50	2"	45	52	0 ÷ 4	3 ÷ 7.5	63	304 stainless steel
ASX23-W050 ² -09012	2/2 DA	50	2"	45	52	0 ÷ 16	3 ÷ 6	90	304 stainless steel
ASX23-W050 ² -12582	2/2 DA	50	2"	45	52	0 ÷ 16	3 ÷ 4	125	aluminium
ASX23-W065 ² -09012	2/2 DA	65	2 1/2"	61	83.2	0 ÷ 10	3 ÷ 7.5	90	304 stainless steel
ASX23-W065 ² -12582	2/2 DA	65	2 1/2"	61	83.2	0 ÷ 16	3 ÷ 6	125	aluminium
ASX23-W080 ² -12582	2/2 DA	80	3"	80	119	0 ÷ 10	3 ÷ 7	125	aluminium
ASX13-W100F2-12582	2/2 DA	100	4"	90	132	0 ÷ 8	3 ÷ 7.5	125	aluminium

Series ASX angle seat valve - 2/2-way DA - pressure above the seat



The valves with flow direction above the seat are suitable for compressible fluids.

NOTE TO THE TABLE:
The indicated models are suitable for operating temperatures from -10 to +180 °C. For higher temperatures, please see the CODING EXAMPLE.
* to complete the code add BODY CONNECTION.

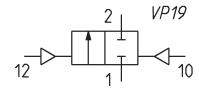

DRAWING LEGEND:
C = valve in closed position
O = valve in open position

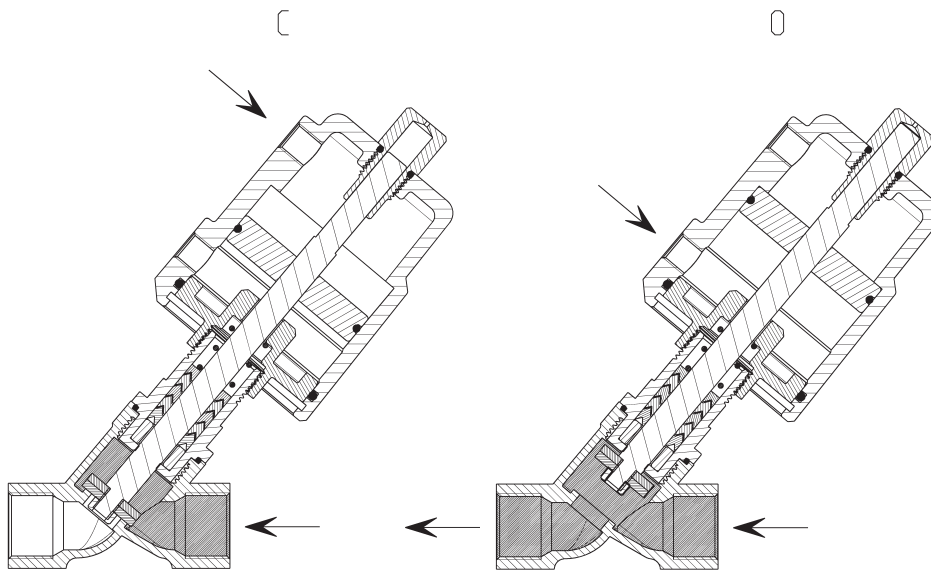

DIMENSIONS									
Mod.	Function	DN	Ports	Orifice Ø (mm)	Kv (m³/h)	Differential pressure min + max (bar)	Minimum piloting pressure (bar)	Actuator Ø (mm)	Actuator material
ASX23-Y008*-04012	2/2 DA	8	1/4"	13	2.2	0 ÷ 16	3 ÷ 4.5	40	304 stainless steel
ASX23-Y008*-05012	2/2 DA	8	1/4"	13	2.2	0 ÷ 16	3 ÷ 3.5	50	304 stainless steel
ASX23-Y010*-04012	2/2 DA	10	3/8"	13	3.9	0 ÷ 16	3 ÷ 4.5	40	304 stainless steel
ASX23-Y010*-05012	2/2 DA	10	3/8"	13	3.9	0 ÷ 16	3 ÷ 3.5	50	304 stainless steel
ASX23-Y015*-04012	2/2 DA	15	1/2"	13	4.3	0 ÷ 16	3 ÷ 4.5	40	304 stainless steel
ASX23-Y015*-05012	2/2 DA	15	1/2"	13	4.3	0 ÷ 16	3 ÷ 3.5	50	304 stainless steel
ASX23-Y020*-05012	2/2 DA	20	3/4"	18	7.6	0 ÷ 16	3 ÷ 4	50	304 stainless steel
ASX23-Y025*-05012	2/2 DA	25	1"	24	15.8	0 ÷ 16	3 ÷ 4.5	50	304 stainless steel
ASX23-Y025*-06312	2/2 DA	25	1"	24	15.8	0 ÷ 16	3 ÷ 3.5	63	304 stainless steel
ASX23-Y032*-06312	2/2 DA	32	1 1/4"	31	26	0 ÷ 16	3 ÷ 5.5	63	304 stainless steel
ASX23-Y032*-09012	2/2 DA	32	1 1/4"	31	26	0 ÷ 16	3 ÷ 4	90	304 stainless steel
ASX23-Y040*-06312	2/2 DA	40	1 1/2"	35	32	0 ÷ 16	3 ÷ 6.5	63	304 stainless steel
ASX23-Y040*-09012	2/2 DA	40	1 1/2"	35	32	0 ÷ 16	3 ÷ 4	90	304 stainless steel
ASX23-Y050*-06312	2/2 DA	50	2"	45	52	0 ÷ 10	3 ÷ 7	63	304 stainless steel
ASX23-Y050*-09012	2/2 DA	50	2"	45	52	0 ÷ 16	3 ÷ 4.5	90	304 stainless steel
ASX23-Y050*-12582	2/2 DA	50	2"	45	52	0 ÷ 16	3 ÷ 4	125	aluminium
ASX23-Y065*-09012	2/2 DA	65	2 1/2"	61	83.2	0 ÷ 10	3 ÷ 6	90	304 stainless steel
ASX23-Y065*-12582	2/2 DA	65	2 1/2"	61	83.2	0 ÷ 16	3 ÷ 4	125	aluminium
ASX23-Y080*-12582	2/2 DA	80	3"	80	119	0 ÷ 12	3 ÷ 7	125	aluminium

Series ASX angle seat valve - dimensions and weight - threaded version

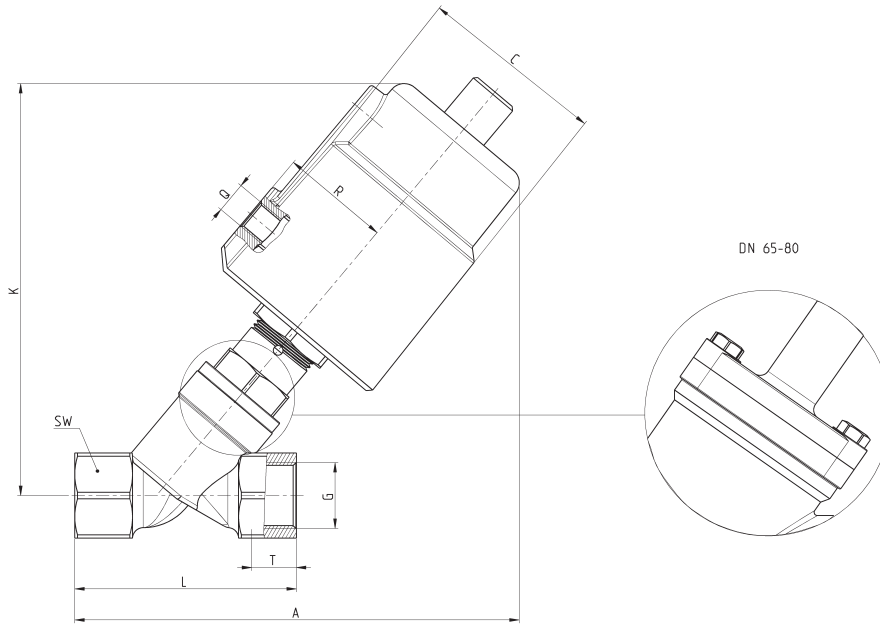

DIMENSIONS											WEIGHT	
DN	Actuator Ø (mm)	G	T	A	L	SW	C	R	K	Q	Below seat (Kgs)	Above seat (Kgs)
8	40	1/4"	12	124	68	27	50.5	27	112	1/8"	0.9	0.9
8	50	1/4"	12	135	68	27	60	33	125	1/8"	1.1	1.1
10	40	3/8"	12	124	68	27	50.5	27	112	1/8"	0.9	0.9
10	50	3/8"	12	135	68	27	60	33	125	1/8"	1.1	1.1
15	40	1/2"	15	124	68	27	50.5	27	112	1/8"	0.9	0.9
15	50	1/2"	15	135	68	27	60	33	125	1/8"	1.1	1.1
20	50	3/4"	16	140	75	32	60	33	132	1/8"	1.2	1.2
25	50	1"	17	150	90	40	60	33	136	1/8"	1.5	1.5
25	63	1"	17	172	90	40	75	41	162	1/8"	2.2	2.1
32	63	1 1/4"	21	190	116	50	75	41	174	1/8"	2.8	2.7
32	90	1 1/4"	21	235	116	50	106	55	223	1/8"	5.0	4.3
40	63	1 1/2"	21	190	116	56	75	41	175	1/8"	2.8	2.8
40	90	1 1/2"	21	235	116	56	106	55	223	1/8"	5.2	4.5
50	63	2"	22	205	138	69	75	41	183	1/8"	3.5	3.5
50	90	2"	22	250	138	69	106	55	232	1/8"	6.1	5.4
50	125	2"	22	305	138	69	170	85	300	1/4"	6.8	6.5
65	90	2 1/2"	26	275	178	85	106	55	280	1/8"	8.5	8.0
65	125	2 1/2"	26	320	178	85	170	85	330	1/4"	10.7	-
80	125	3"	27	340	210	100	170	85	355	1/4"	14.1	-

Series ASX angle seat valve - dimensions and weight - welding ends version

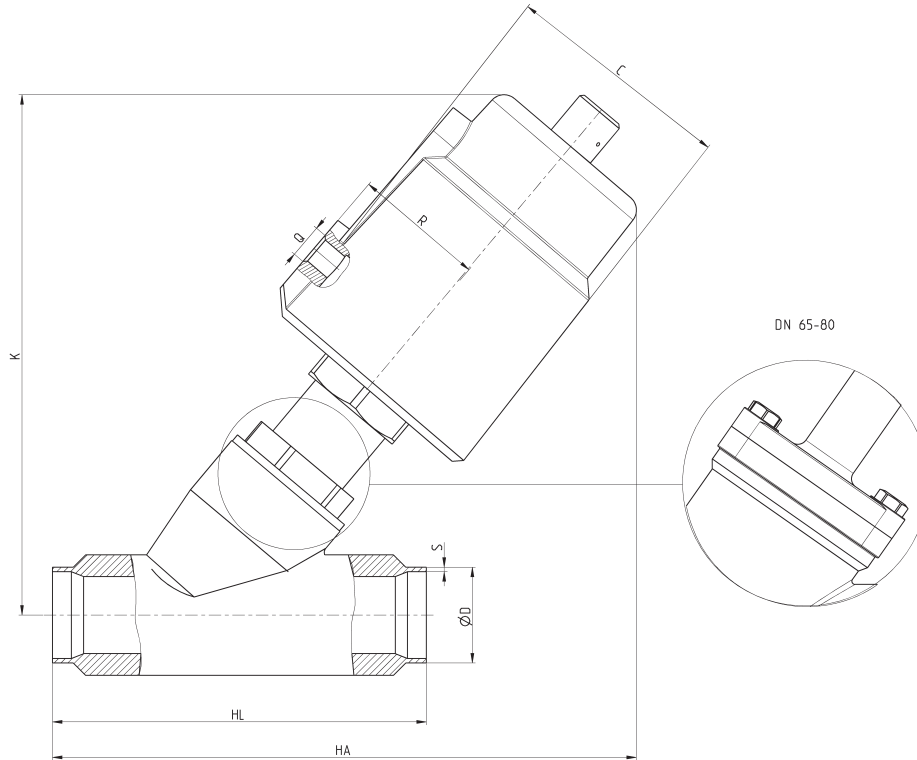

DIMENSIONS											WEIGHT		
DN	Actuator Ø (mm)	DIN11850-2 ØD	DIN11850-2 S	DIN11850-3 ØD	DIN11850-3 S	HA	HL	C	R	K	Q	Below seat (Kgs)	Above seat (Kgs)
15	40	19	1.5	20	2	118	70	50.5	27	112	1/8"	0.9	0.9
15	50	19	1.5	20	2	128	70	60	33	125	1/8"	1.1	1.1
20	50	23	1.5	24	2	135	82	60	33	132	1/8"	1.2	1.2
25	50	29	1.5	30	2	150	100	60	33	136	1/8"	1.5	1.5
25	63	29	1.5	30	2	175	100	75	41	162	1/8"	2.2	2.1
32	63	35	1.5	36	2	186	125	75	41	174	1/8"	2.6	2.5
32	90	35	1.5	36	2	232	125	106	55	223	1/8"	4.9	4.2
40	63	41	1.5	42	2	190	130	75	41	175	1/8"	2.8	2.8
40	90	41	1.5	42	2	235	130	106	55	223	1/8"	5.1	4.4
50	63	53	1.5	54	2	206	155	75	41	183	1/8"	3.4	3.4
50	90	53	1.5	54	2	250	155	106	55	232	1/8"	6.0	5.3
50	125	53	1.5	54	2	307	155	170	85	300	1/4"	6.7	6.5
65	90	70	2	-	-	320	270	106	55	280	1/8"	8.8	12.9
65	125	70	2	-	-	360	270	170	85	330	1/4"	10.7	-
80	125	85	2	-	-	360	284	170	85	355	1/4"	14.0	-

Series ASX angle seat valve - dimensions and weight - flanged version



SERIES ASX ANGLE SEAT VALVES

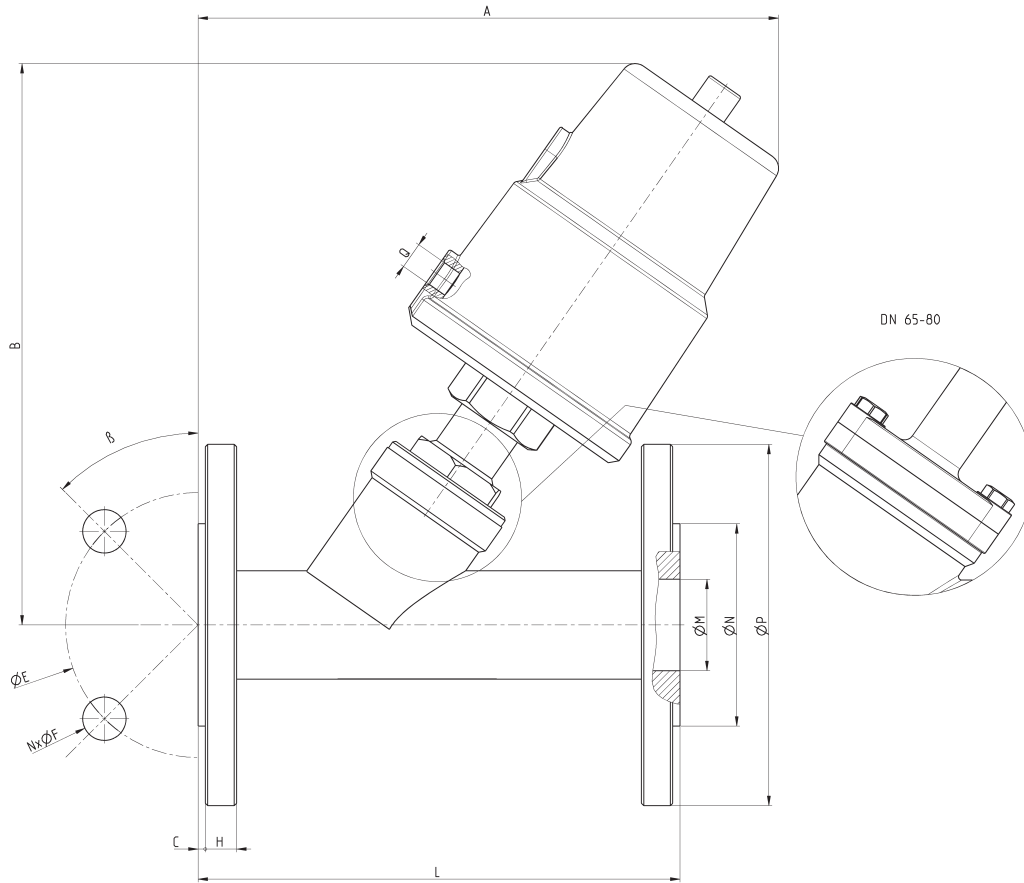

DIMENSIONS													WEIGHT		
DN	Actuator Ø (mm)	ØM	ØN	ØP	ØE	NxØF	β	A	B	L	C	H	Q	Below seat (Kgs)	Above seat (Kgs)
15	40	16	45	95	65	4x14	45°	135	125	130	2	14	1/8"	2.1	2.1
15	50	16	45	95	65	4x14	45°	145	140	130	2	14	1/8"	2.4	2.4
20	50	19	56	105	75	4x14	45°	165	140	150	2	14	1/8"	2.9	2.9
25	50	26	65	115	85	4x14	45°	170	145	160	2	14	1/8"	3.5	3.5
25	63	26	65	115	85	4x14	45°	190	175	160	2	14	1/8"	5.6	5.5
32	63	31	78	140	100	4x18	45°	190	188	180	2	16	1/8"	5.8	5.7
32	90	31	78	140	100	4x18	45°	230	235	180	2	16	1/8"	8.0	7.3
40	63	38	84	150	110	4x18	45°	206	190	200	3	16	1/8"	6.6	6.5
40	90	38	84	150	110	4x18	45°	250	240	200	3	16	1/8"	9.0	8.3
50	63	49	100	165	125	4x18	45°	235	195	230	3	16	1/8"	8.1	8.0
50	90	49	100	165	125	4x18	45°	277	245	230	3	16	1/8"	10.4	9.7
50	125	49	100	165	125	4x18	45°	330	310	230	3	16	1/4"	13.3	13.0
65	90	66	120	185	145	4x18	45°	330	280	290	3	18	1/8"	13.8	12.9
65	125	66	120	185	145	4x18	45°	375	330	290	3	18	1/4"	14.7	-
80	125	78	135	200	160	8x18	22.5°	380	355	310	3	20	1/4"	21.9	-
100	125	96	155	215	180	8x18	22.5°	420	395	350	3	20	1/4"	-	-

Series ASX angle seat valve - dimensions and weight - tri-clamp version

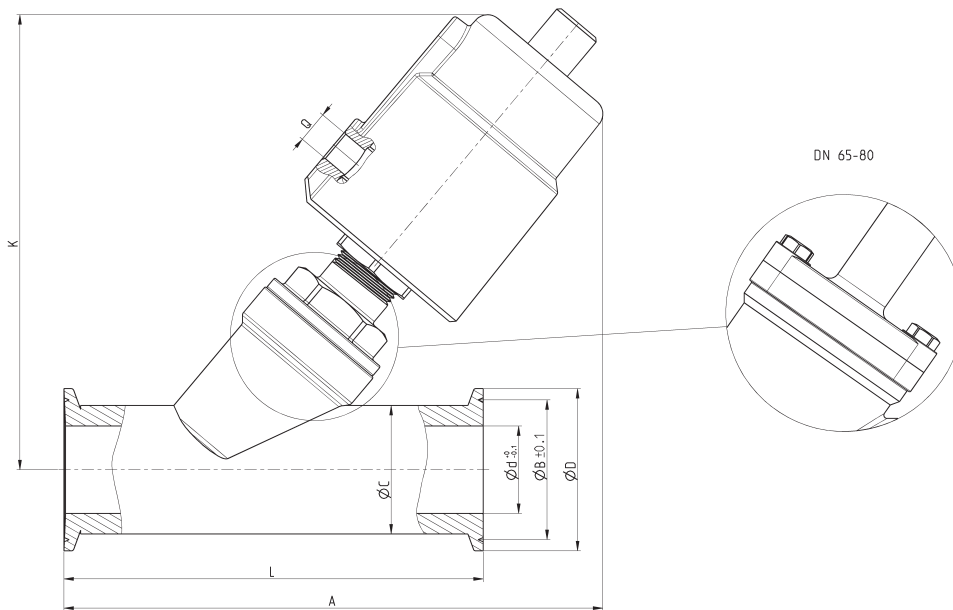

DIMENSIONS								WEIGHT			
DN	Actuator Ø (mm)	ØC	ØB	Ød	ØD	A	K	L	Q	Below seat (Kgs)	Above seat (Kgs)
15	40	19	27.5	15	34	130	115	80	1/8"	0.9	0.9
15	50	19	27.5	15	34	140	126	80	1/8"	1.1	1.1
20	50	25	43.5	19	50.5	158	148	130	1/8"	1.4	1.4
25	50	32	43.5	27	50.5	165	140	130	1/8"	1.6	1.6
25	63	32	43.5	27	50.5	188	166	130	1/8"	2.3	2.2
32	63	37	43.5	31	50.5	200	174	146	1/8"	2.7	2.6
32	90	37	43.5	31	50.5	245	223	146	1/8"	5.0	4.3
40	63	40	56.5	33	64	210	175	160	1/8"	3.0	2.9
40	90	40	56.5	33	64	255	223	160	1/8"	5.3	4.5
50	63	53	56.5	45	64	221	185	175	1/8"	3.4	2.4
50	90	53	56.5	45	64	265	235	175	1/8"	6.2	5.2
50	125	53	56.5	45	64	325	296	175	1/4"	7.0	6.7
65	90	75	83.5	66	91	325	280	278	1/8"	7.9	7.6
65	125	75	83.5	66	91	360	330	278	1/4"	11.3	-
80	125	89	97	78	106	360	352	290	1/4"	-	-

Series ASX angle seat valve - options - proximity switch



Available on all models of angle seat valves to control the state of the open valve.
 Type: NPN, NO or NC - PNP, NO or NC - SCR, NO or NC
 Switching distance: 3 mm ± 10%
 Operating temperature: -25 ÷ 70 °C
 Body material: nickel-plated brass
 Sensor material: ABS
 Protection class: IP67

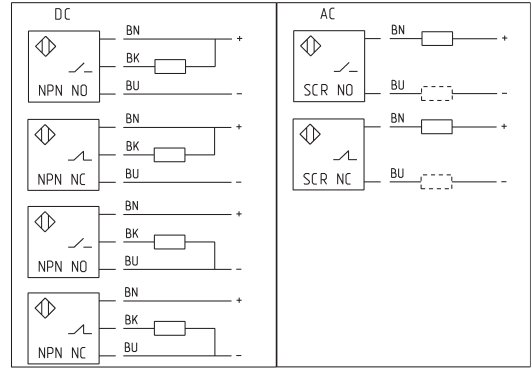

PS1	NPN type - NO contact - 10 ÷ 30 V DC power supply
PS2	NPN type - NC contact - 10 ÷ 30 V DC power supply
PS3	PNP type - NO contact - 10 ÷ 30 V DC power supply
PS4	PNP type - NC contact - 10 ÷ 30 V DC power supply
PS5	SCR type - NO contact - 20 ÷ 250 V AC power supply
PS6	SCR type - NC contact - 20 ÷ 250 V AC power supply

Series ASX angle seat valve - options - position indicator



Available on all models of angle seat valves to control the state of the open and closed valve.
 Type of limit switch: mechanical micro-switch
 Operating voltage: 12 ÷ 36 V DC
 Operating current: 25 mA / 24 V DC
 Adjustment range: 5 ÷ 30 mm
 Operating temperature: -30 ÷ 80 °C
 Housing material: PA6/GF30 + PC
 Protection class: IP65

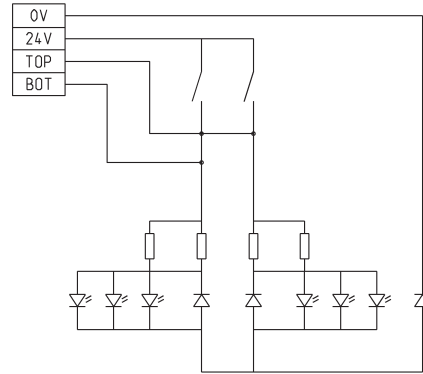

PI1	Position indicator for Ø40 - Ø50 - Ø63 - Ø90 mm actuators
PI2	Position indicator for Ø125 mm actuators

Series ASX angle seat valve - options - stroke limiter



Available only for Ø50 - Ø63 - Ø90 mm actuators to limit the actuator's stroke from 0 to 100% in order to adjust the maximum flow.

SL1	Stroke limiter for Ø50 - Ø63 mm actuators
SL2	Stroke limiter for Ø90 mm actuators

Series ASP angle seat valves

Coming soon

2/2-way - Normally Closed (NC) and Normally Open (NO)
2/2-way - Double Acting (DA)



The Series ASP angle seat valves are an efficient and cost-effective solution for fluid control. Their robustness is suitable for the most varied applications with inert gases and liquids, with steam or with fluids having solid particulates in suspension. Available with 3/8" to 2-1/2" threaded connections.

- » Differential pressure up to 20 bar
- » High flow
- » Low resistance of the flow
- » Anti-water hammer design
- » Compliant with Directive PED 2014/68/UE

The operation is determined by the pneumatic drive of a single acting, guided piston actuator with spring return. There are also models available with double acting actuators, without spring. For liquid media we recommend the models with flow direction under the seat. For gas or steam we recommend the models with flow direction above the seat.

GENERAL DATA

TECHNICAL FEATURES

Function	2/2 NC - 2/2 NO - 2/2 Double Acting
Operation	pneumatic, poppet type
Pneumatic connections	3/8 ... 2-1/2" with BSP thread (NPT on demand)
Nominal diameter	DN10 ... DN65
Flow coefficient Kv (m ³ /h)	2.6 ... 65
Operating pressure	0 ÷ 6 ... 20 bar
Operating temperature	-20 ÷ 130 °C
Media	water, air, steam, inert liquids and gases (compatible with the materials in contact)
Viscosity	600 cSt. max
Installation	in any position

MATERIALS IN CONTACT WITH THE MEDIUM

Body	brass
Seals	EPDM
Internal parts	304 stainless steel

SPECIFICATIONS PNEUMATIC ACTUATOR

Actuator dimensions	Ø50 - Ø63 - Ø80 - Ø100 mm
Actuator material	PA66 polyamide 30% GF
Piston material	aluminium
Piston seal material	PUR
Piloting fluid	air or inert gases
Piloting pressure	10 bar max.
Actuator position	360° rotatable

CODING EXAMPLE

AS	P	A	1	-	W	015	G1	-	050	P	2
-----------	----------	----------	----------	----------	----------	------------	-----------	----------	------------	----------	----------

AS	SERIES
P	TYPE OF ACTUATOR P = technopolymer actuator
A	BODY MATERIAL A = brass
1	NUMBER OF WAYS - FUNCTIONS 0 = 2/2-way NO 1 = 2/2-way NC 3 = 2/2-way DA (Double Acting)
W	FLOW DIRECTION W = under the seat (liquids and gases, anti-water hammer) Y = above the seat (gases)
015	NOMINAL DIAMETER 010 = DN 10 015 = DN 15 020 = DN 20 025 = DN 25 032 = DN 32 040 = DN 40 050 = DN 50 065 = DN 65
G1	BODY CONNECTION G1 = BSP thread DIN 228-1 N1 = NPT thread ASME B1.20.1 (on demand)
050	ACTUATOR DIMENSION 050 = Ø50 mm 063 = Ø63 mm 080 = Ø80 mm 100 = Ø100 mm
P	ACTUATOR MATERIAL P = PA66 polyamide 30% GF
2	SEALS 2 = for standard temperatures -20 ÷ 130 °C

Series ASP angle seat valve - 2/2-way NC - pressure under the seat



The valves with flow direction under the seat are suitable for incompressible fluids. This function prevents the hydraulic water hammer effect.

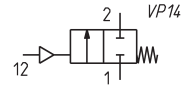

DRAWING LEGEND:
 C = valve in closed position
 O = valve in open position

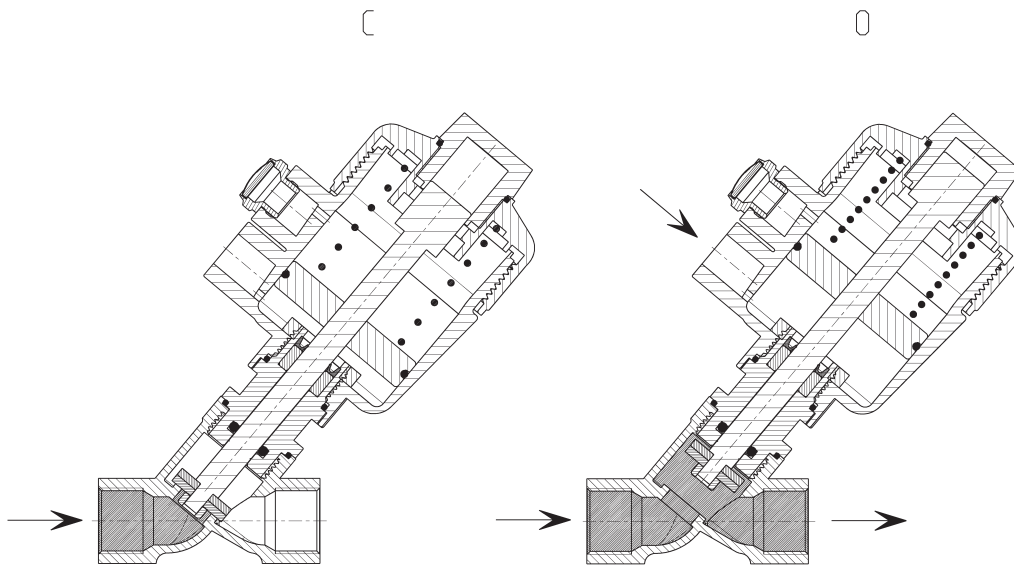

Mod.	Function	DN	Ports	Orifice Ø (mm)	Kv (m³/h)	Differential pressure min ÷ max (bar)	Minimum piloting pressure (bar)	Actuator Ø (mm)	Actuator material
ASPA1-W010G1-050P2	2/2 NC	10	G3/8"	12	2.6	0 ÷ 20	≥ 6	50	PA66
ASPA1-W015G1-050P2	2/2 NC	15	G1/2"	12	3.5	0 ÷ 18	≥ 6	50	PA66
ASPA1-W015G1-063P2	2/2 NC	15	G1/2"	12	3.5	0 ÷ 20	≥ 6	63	PA66
ASPA1-W020G1-050P2	2/2 NC	20	G3/4"	17	8.6	0 ÷ 14	≥ 6	50	PA66
ASPA1-W020G1-063P2	2/2 NC	20	G3/4"	17	8.6	0 ÷ 18	≥ 6	63	PA66
ASPA1-W025G1-050P2	2/2 NC	25	G1"	21	9.7	0 ÷ 9	≥ 6	50	PA66
ASPA1-W025G1-063P2	2/2 NC	25	G1"	21	9.7	0 ÷ 14	≥ 6	63	PA66
ASPA1-W032G1-063P2	2/2 NC	32	G1 1/4"	30	26.7	0 ÷ 10	≥ 6	63	PA66
ASPA1-W032G1-080P2	2/2 NC	32	G1 1/4"	30	26.7	0 ÷ 16	≥ 6	80	PA66
ASPA1-W040G1-080P2	2/2 NC	40	G1 1/2"	37	40.4	0 ÷ 11	≥ 6	80	PA66
ASPA1-W040G1-100P2	2/2 NC	40	G1 1/2"	37	40.4	0 ÷ 20	≥ 6	100	PA66
ASPA1-W050G1-080P2	2/2 NC	50	G2"	46	55	0 ÷ 6	≥ 6	80	PA66
ASPA1-W050G1-100P2	2/2 NC	50	G2"	46	55	0 ÷ 12	≥ 6	100	PA66
ASPA1-W065G1-100P2	2/2 NC	65	2 1/2"	59	65	0 ÷ 6	≥ 6	100	PA66

Series ASP angle seat valve - 2/2-way NC - pressure above the seat



The valves with flow direction above the seat are suitable for compressible fluids.

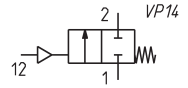

DRAWING LEGEND:
C = valve in closed position
O = valve in open position

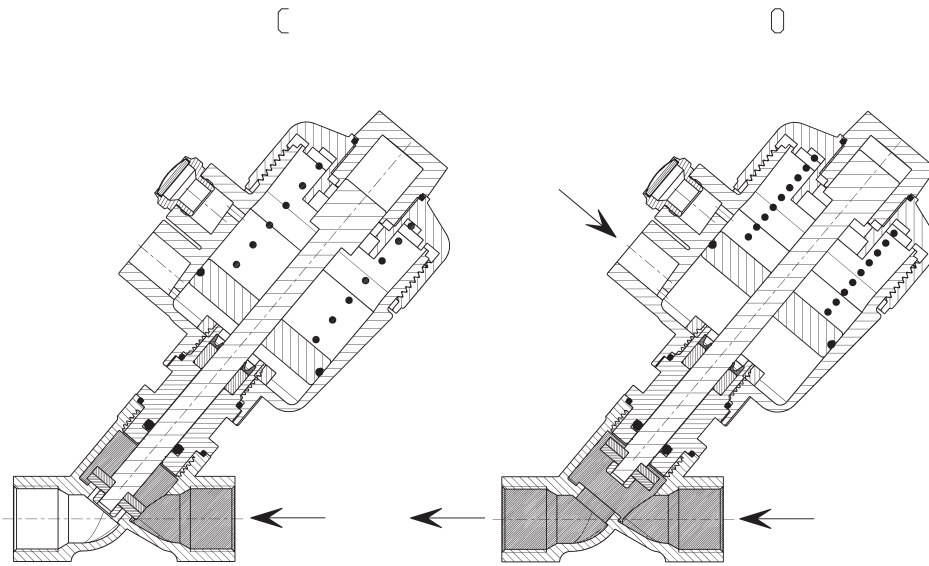

Mod.	Function	DN	Ports	Orifice Ø (mm)	Kv (m³/h)	Differential pressure min ÷ max (bar)	Minimum piloting pressure (bar)	Actuator Ø(mm)	Actuator material
ASPA1-Y010G1-050P2	2/2 NC	10	G3/8"	12	2.6	0 ÷ 20	≥ 6	50	PA66
ASPA1-Y015G1-050P2	2/2 NC	15	G1/2"	12	3.5	0 ÷ 20	≥ 6	50	PA66
ASPA1-Y015G1-063P2	2/2 NC	15	G1/2"	12	3.5	0 ÷ 20	≥ 6	63	PA66
ASPA1-Y020G1-050P2	2/2 NC	20	G3/4"	17	8.6	0 ÷ 20	≥ 6	50	PA66
ASPA1-Y020G1-063P2	2/2 NC	20	G3/4"	17	8.6	0 ÷ 20	≥ 6	63	PA66
ASPA1-Y025G1-050P2	2/2 NC	25	G1"	21	9.7	0 ÷ 20	6 ÷ 8.8	50	PA66
ASPA1-Y025G1-063P2	2/2 NC	25	G1"	21	9.7	0 ÷ 20	≥ 6	63	PA66
ASPA1-Y032G1-063P2	2/2 NC	32	G1 1/4"	30	26.7	0 ÷ 20	6 ÷ 8	63	PA66
ASPA1-Y032G1-080P2	2/2 NC	32	G1 1/4"	30	26.7	0 ÷ 20	6 ÷ 7.5	80	PA66
ASPA1-Y040G1-080P2	2/2 NC	40	G1 1/2"	37	40.4	0 ÷ 20	6 ÷ 9	80	PA66
ASPA1-Y040G1-100P2	2/2 NC	40	G1 1/2"	37	40.4	0 ÷ 20	6 ÷ 6.7	100	PA66
ASPA1-Y050G1-080P2	2/2 NC	50	G2"	46	55	0 ÷ 14	6 ÷ 10	80	PA66
ASPA1-Y050G1-100P2	2/2 NC	50	G2"	46	55	0 ÷ 20	6 ÷ 7.8	100	PA66
ASPA1-Y065G1-100P2	2/2 NC	65	2 1/2"	59	65	0 ÷ 16	6 ÷ 8.2	100	PA66

Series ASP angle seat valve - 2/2-way NO - pressure under the seat



The valves with flow direction under the seat are suitable for incompressible fluids. This function prevents the hydraulic water hammer effect.

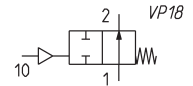

DRAWING LEGEND:
 C = valve in closed position
 O = valve in open position

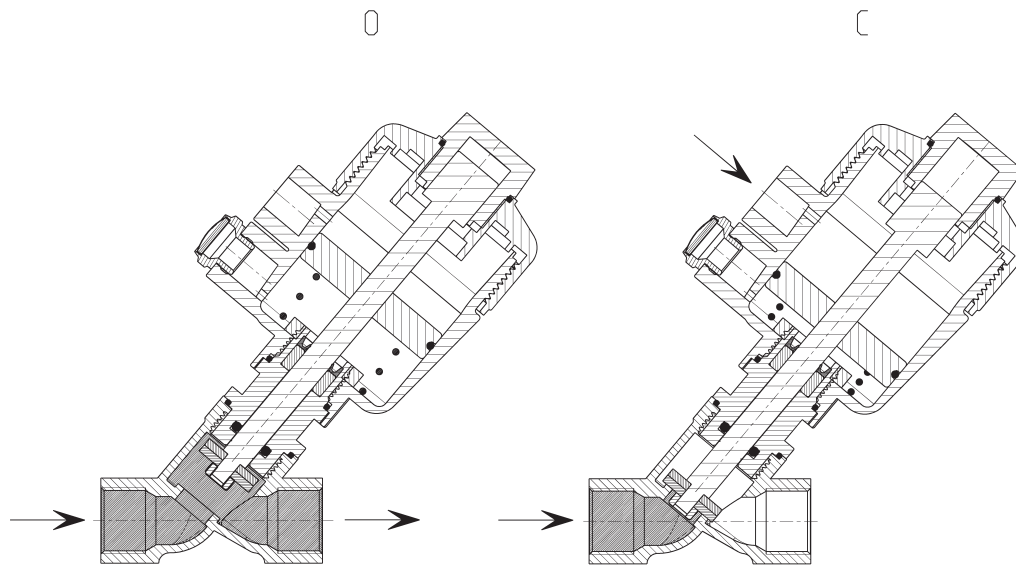

Mod.	Function	DN	Ports	Orifice Ø (mm)	Kv (m³/h)	Differential pressure min ÷ max (bar)	Minimum piloting pressure (bar)	Actuator Ø (mm)	Actuator material
ASPA0-W010G1-050P2	2/2 NO	10	G3/8"	12	2.6	0 ÷ 20	≥ 6	50	PA66
ASPA0-W015G1-050P2	2/2 NO	15	G1/2"	12	3.5	0 ÷ 20	≥ 6	50	PA66
ASPA0-W015G1-063P2	2/2 NO	15	G1/2"	12	3.5	0 ÷ 20	≥ 6	63	PA66
ASPA0-W020G1-050P2	2/2 NO	20	G3/4"	17	8.6	0 ÷ 20	6 ÷ 6.3	50	PA66
ASPA0-W020G1-063P2	2/2 NO	20	G3/4"	17	8.6	0 ÷ 20	≥ 6	63	PA66
ASPA0-W025G1-050P2	2/2 NO	25	G1"	21	9.7	0 ÷ 20	6 ÷ 8.7	50	PA66
ASPA0-W025G1-063P2	2/2 NO	25	G1"	21	9.7	0 ÷ 20	6 ÷ 6.3	63	PA66
ASPA0-W032G1-063P2	2/2 NO	32	G1 1/4"	30	26.7	0 ÷ 20	6 ÷ 9.3	63	PA66
ASPA0-W032G1-080P2	2/2 NO	32	G1 1/4"	30	26.7	0 ÷ 20	≥ 6	80	PA66
ASPA0-W040G1-080P2	2/2 NO	40	G1 1/2"	37	40.4	0 ÷ 20	6 ÷ 8.5	80	PA66
ASPA0-W040G1-100P2	2/2 NO	40	G1 1/2"	37	40.4	0 ÷ 20	≥ 6	100	PA66
ASPA0-W050G1-080P2	2/2 NO	50	G2"	46	55	0 ÷ 16	6 ÷ 10	80	PA66
ASPA0-W050G1-100P2	2/2 NO	50	G2"	46	55	0 ÷ 20	6 ÷ 7.4	100	PA66
ASPA0-W065G1-100P2	2/2 NO	65	2 1/2"	59	65	0 ÷ 14	6 ÷ 10	100	PA66

Series ASP angle seat valve - 2/2-way DA - pressure under the seat



The valves with flow direction under the seat are suitable for incompressible fluids. This function prevents the hydraulic water hammer effect.

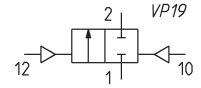

DRAWING LEGEND:
C = valve in closed position
O = valve in open position

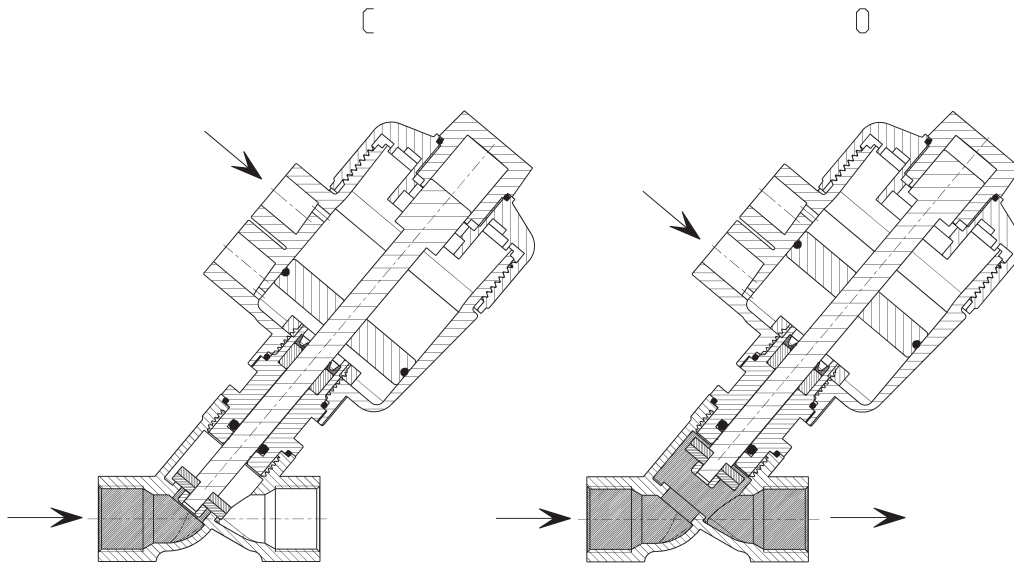

Mod.	Function	DN	Ports	Orifice Ø (mm)	Kv (m³/h)	Differential pressure min + max (bar)	Minimum piloting pressure (bar)	Actuator Ø (mm)	Actuator material
ASPA3-W010G1-050P2	2/2 DE	10	G3/8"	12	2.6	0 ÷ 20	≥ 6	50	PA66
ASPA3-W015G1-050P2	2/2 DE	15	G1/2"	12	3.5	0 ÷ 20	≥ 6	50	PA66
ASPA3-W015G1-063P2	2/2 DE	15	G1/2"	12	3.5	0 ÷ 20	≥ 6	63	PA66
ASPA3-W020G1-050P2	2/2 DE	20	G3/4"	17	8.6	0 ÷ 20	≥ 6	50	PA66
ASPA3-W020G1-063P2	2/2 DE	20	G3/4"	17	8.6	0 ÷ 20	≥ 6	63	PA66
ASPA3-W025G1-050P2	2/2 DE	25	G1"	21	9.7	0 ÷ 20	6 ÷ 8.3	50	PA66
ASPA3-W025G1-063P2	2/2 DE	25	G1"	21	9.7	0 ÷ 20	≥ 6	63	PA66
ASPA3-W032G1-063P2	2/2 DE	32	G1 1/4"	30	26.7	0 ÷ 20	6 ÷ 8	63	PA66
ASPA3-W032G1-080P2	2/2 DE	32	G1 1/4"	30	26.7	0 ÷ 20	≥ 6	80	PA66
ASPA3-W040G1-080P2	2/2 DE	40	G1 1/2"	37	40.4	0 ÷ 20	6 ÷ 7.7	80	PA66
ASPA3-W040G1-100P2	2/2 DE	40	G1 1/2"	37	40.4	0 ÷ 20	≥ 6	100	PA66
ASPA3-W050G1-080P2	2/2 DE	50	G2"	46	55	0 ÷ 16	6 ÷ 10	80	PA66
ASPA3-W050G1-100P2	2/2 DE	50	G2"	46	55	0 ÷ 20	6 ÷ 6.7	100	PA66
ASPA3-W065G1-100P2	2/2 DE	65	2 1/2"	59	65	0 ÷ 14.5	6 ÷ 10	100	PA66

Series ASP angle seat valve - 2/2-way DA - pressure above the seat



The valves with flow direction above the seat are suitable for compressible fluids.

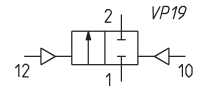

DRAWING LEGEND:
 C = valve in closed position
 O = valve in open position

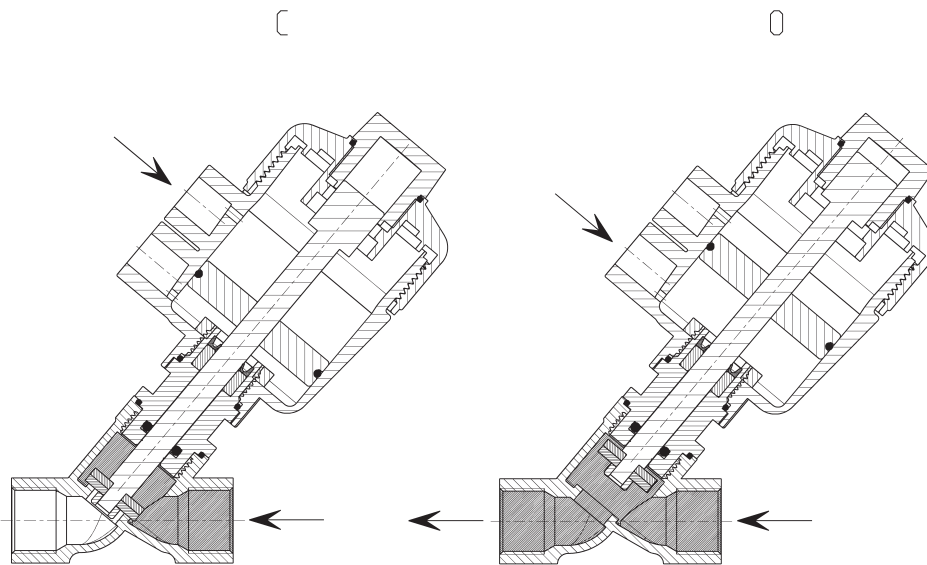

Mod.	Function	DN	Ports	Orifice Ø (mm)	Kv (m ³ /h)	Differential pressure min ÷ max (bar)	Minimum piloting pressure (bar)	Actuator Ø(mm)	Actuator material
ASPA3-Y010G1-050P2	2/2 DE	10	G3/8"	12	2.6	0 ÷ 20	≥ 6	50	PA66
ASPA3-Y015G1-050P2	2/2 DE	15	G1/2"	12	3.5	0 ÷ 20	≥ 6	50	PA66
ASPA3-Y015G1-063P2	2/2 DE	15	G1/2"	12	3.5	0 ÷ 20	≥ 6	63	PA66
ASPA3-Y020G1-050P2	2/2 DE	20	G3/4"	17	8.6	0 ÷ 20	≥ 6	50	PA66
ASPA3-Y020G1-063P2	2/2 DE	20	G3/4"	17	8.6	0 ÷ 20	≥ 6	63	PA66
ASPA3-Y025G1-050P2	2/2 DE	25	G1"	21	9.7	0 ÷ 20	6 ÷ 8.3	50	PA66
ASPA3-Y025G1-063P2	2/2 DE	25	G1"	21	9.7	0 ÷ 20	≥ 6	63	PA66
ASPA3-Y032G1-063P2	2/2 DE	32	G1 1/4"	30	26.7	0 ÷ 20	6 ÷ 8	63	PA66
ASPA3-Y032G1-080P2	2/2 DE	32	G1 1/4"	30	26.7	0 ÷ 20	≥ 6	80	PA66
ASPA3-Y040G1-080P2	2/2 DE	40	G1 1/2"	37	40.4	0 ÷ 20	6 ÷ 7.7	80	PA66
ASPA3-Y040G1-100P2	2/2 DE	40	G1 1/2"	37	40.4	0 ÷ 20	≥ 6	100	PA66
ASPA3-Y050G1-080P2	2/2 DE	50	G2"	46	55	0 ÷ 16	6 ÷ 10	80	PA66
ASPA3-Y050G1-100P2	2/2 DE	50	G2"	46	55	0 ÷ 20	6 ÷ 6.7	100	PA66
ASPA3-Y065G1-100P2	2/2 DE	65	2 1/2"	59	65	0 ÷ 14.5	6 ÷ 10	100	PA66

Series ASP angle seat valve - dimensions and weight

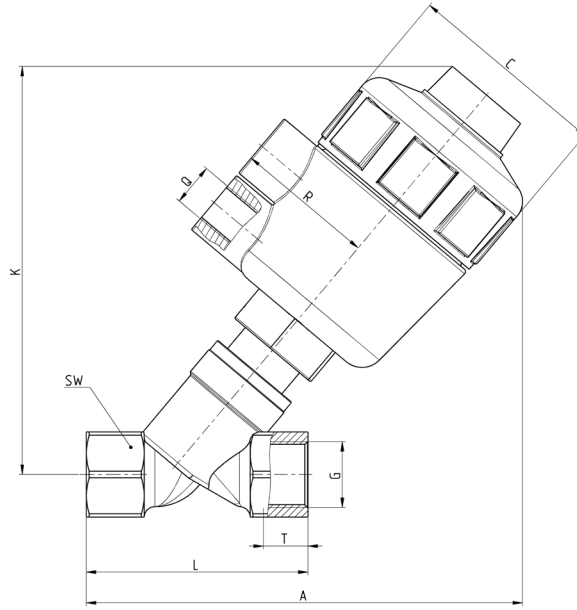

DIMENSIONS											WEIGHT
DN	Actuator Ø (mm)	G	T	A	L	SW	C	R	K	Q	Kg
10	50	3/8"	12	125	49	21	66	45	115	G1/4"	0.8
15	50	1/2"	13	130	55	26	66	45	115	G1/4"	0.9
15	63	1/2"	13	160	55	26	83	52	150	G1/4"	1.2
20	50	3/4"	13.5	135	65.5	31	66	45	115	G1/4"	1.0
20	63	3/4"	13.5	165	65.5	31	83	52	150	G1/4"	1.3
25	50	1"	16	140	76	38	66	45	115	G1/4"	1.3
25	63	1"	16	170	76	38	83	52	150	G1/4"	1.6
32	63	1 1/4"	18	180	96	48	83	52	180	G1/4"	2.1
32	80	1 1/4"	18	210	96	48	103	60	210	G1/4"	1.6
40	80	1 1/2"	18.5	220	101	54	103	60	220	G1/4"	2.6
40	100	1 1/2"	18.5	230	101	54	130	73	230	G1/4"	4.5
50	80	2"	19	230	120	67	103	60	230	G1/4"	2.9
50	100	2"	19	240	120	67	130	73	240	G1/4"	5.3
65	100	2 1/2"	23	250	149	85	130	73	240	G1/4"	6.5

Solenoids

GP... - B7... - G93 - U7... - U7...EX - G7... - A8... - B8... - H8... - B9...

Version A and B

Connections according to industrial standard and to DIN EN 175 301-803 standards

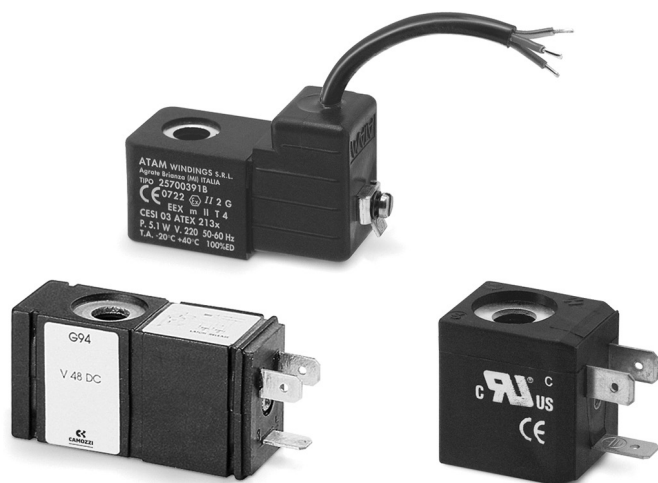

The mechanical part of the tube in the solenoid valves Series A, 3, 4, 9 and NA allows the mounting of various types of solenoids.

- » Mod. GP...: in compliance with industrial standard (9.4mm) and designed to be mounted only on Series AP proportional valves, size 16 mm.
- » Mod. B...: to be used only with Series CFB solenoid valves (2/1.30).
- » Mod. G93: special solenoids with incorporated memory for pulsed operation.
- » Mod. U7...: standard solenoids are certified by UL as Recognized Component for USA and Canada. Solenoids Mod. U7 are available also with ATEX certification.
- » Mod. H8...: explosion-proof solenoids suitable for potentially explosive ambients (ATEX, IECEx).

GENERAL DATA

	U7... / G7... / G93	A8...	B...	H8...
Wire insulation	class F (155° C)	class H (180° C)	class H (200° C)	class H (200° C)
Protection class	IP54 - DIN 40050	IP54 - DIN 40050	IP54 - DIN 40050	IP64
	IP65 (with connector Mod. 122-800 and Mod. 122-800EX)	IP65 (with connector Mod. 124-800)	IP65 (with connector Mod. 124-800)	
Operation	ED 100%	ED 100%	ED 100%	ED 100%
Tolerance V AC	-15% / +10%	-15% / +10%	±10%	-
Tolerance V DC	±10%	±10%	±5%	-

Solenoids Mod. GP...

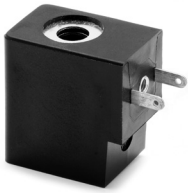

Electrical connection: bipolar
Norm: industrial standard (9.4 mm)

Solenoid material: PA

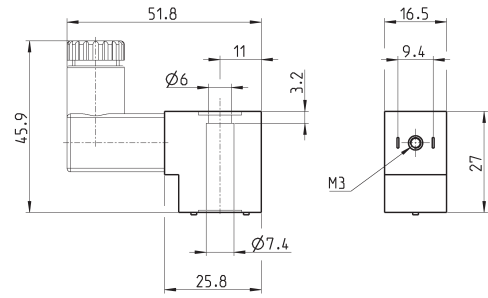

Mod.	Solenoid voltage	Power absorption
GPB	12 V DC	3 W
GP7	24 V DC	3 W

Solenoids Mod. B7...



Electrical connection: bipolar plus earth
Norm: DIN EN 175 301-803-B

Solenoid material: PA-MXD6

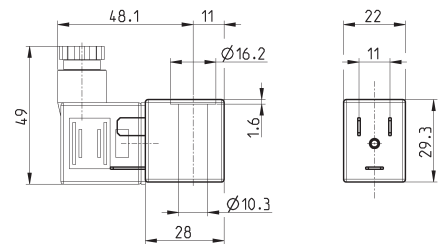

Mod.	Solenoid voltage	Power absorption
B7B	24 V - 50/60 Hz	9 VA
B7D	110 V - 50/60 Hz	9 VA
B7E	230 V - 50/60 Hz	9 VA
B7H	24 V - 50/60 Hz	4 VA
B72	12 V - DC	10 W
B721	12 V - DC	14 W
B73	24 V - DC	10 W
B731	24 V - DC	14 W
B74	24 V - DC	7 W

Solenoids Mod. G93 (with memory)



Electrical connection: bipolar plus earth
Norm: DIN EN 175 301-803-B
Voltage tolerance: ±10%
Pulsed operation (see description)

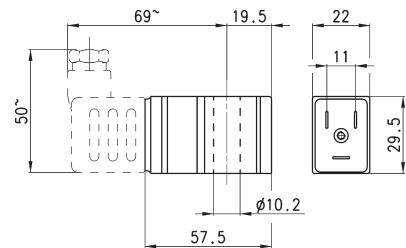

Mod.	Voltage	Minimum impulse latch/release	Consumption latch/release
G92	12 V DC	18 ms - 10 ms	200 mA - 160 mA
G93	24 V DC	18 ms - 10 ms	100 mA - 80 mA

Description of solenoids Mod. G9...

Solenoids Mod. G9... can be replaced on all other Series A solenoid valves or pilots allowing to change the valve functioning from:

- unstable functioning system (spring return) to:
- stable functioning system (memory)

The stable functioning has the following advantages:

- with an impulse of about 20 ms after which the valve always remains in the controlled position.
- the valve remains in the controlled position (opened or closed) even if there is no power.
- when normally opened valves should be used, it is not necessary to use valves with special mechanical parts as a NC valve becomes a NO valve just by changing the control impulse sequence.
- The impulse control system facilitates the utilization with electronic circuits. The minimum required impulse for the function is 20 ms; if, for circuit reasons, the impulse last for a longer period, there is no danger of heating.
- magnet attraction command = Actuation SW1
- magnet release command = Actuation SW2

If the solenoids are mounted in batteries, a magnetic scheme type G90/L should be used.

To facilitate the cabling a special connector is available, which contains a circuit which realises the inversion of the power supply to the solenoid, indispensable for the PLC command, 122-892 P with common positive or 122-893 N with common negative.

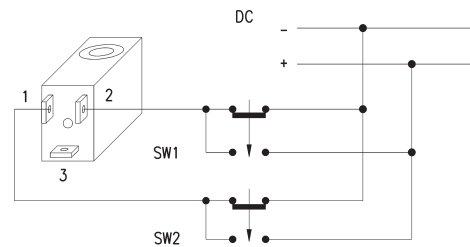
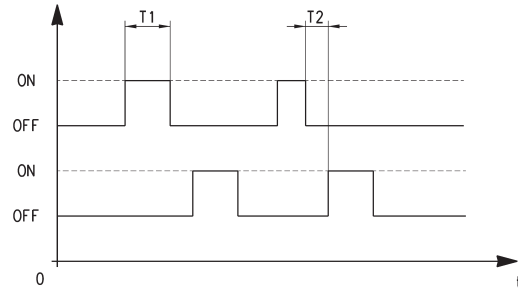

SOLENOIDS

Solenoids Mod. U7... / U7*EX and Mod. G7...



Electrical connection: bipolar plus earth
 Norm: DIN EN 175 301-803-B
 Solenoid material: U7* = PET; G7* = PA
 To order the ATEX version of Mod. U7 (not available for Mod. U7F, U7K1 with voltage 125V 50/60Hz) it is necessary to add EX at the end of the code.
 Mod. U7*EX marked:
 II 3G Ex nA IIC T4 Gc X IP65
 II 3D Ex tc IIC 130°C Dc X

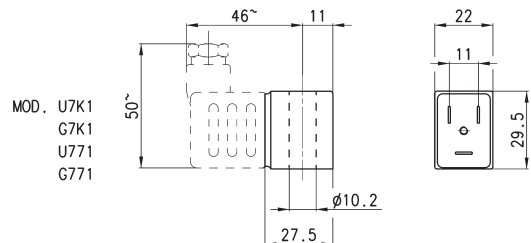
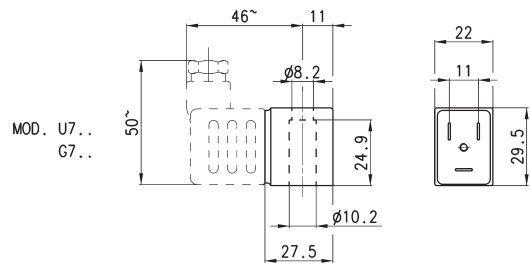

Mod.	Sol. volt. (1)	Pow. abs. (1)	Sol. volt. (2)	Pow. abs. (2)	Sol. volt. (3)	Pow. abs. (3)
U7H	12 V DC	3.1 W	24V - 50/60 Hz	3.5 VA		
G7H	12 V DC	3.1 W	24V - 50/60Hz	3.5 VA		
U7K	110V - 50/60Hz	3.8 VA	125V - 50/60Hz	5.5 VA	72 V DC	4.8 W
U7K1	110V - 50/60Hz	5.8 VA	125V - 50/60Hz	8.3 VA	72 V DC	5.6 W
G7K	110V - 50/60Hz	3.8 VA	125V - 50/60Hz	5.5 VA	72 V DC	4.8 W
G7K1	110V - 50/60Hz	5.8 VA	125V - 50/60Hz	8.3 VA	72 V DC	5.6 W
U7J	230V - 50/60Hz	3.5 VA	240V - 50/60Hz	4 VA		
G7J	230V - 50/60Hz	3.5 VA	240V - 50/60Hz	4 VA		
U79	48 V DC	3.1 W				
G79	48 V DC	3.1 W				
U710	110 V DC	3.2 W				
G710	110 V DC	3.2 W				
U77	24 V DC	3.1 W	48V - 50/60Hz	3.8 VA		
U771	24 V DC	3.1 W	48V - 50/60Hz	3.8 VA		
G77	24 V DC	3.1 W	48V - 50/60Hz	3.8 VA		
G771	24 V DC	3.1 W	48V - 50/60Hz	3.8 VA		
U7F	380V - 50/60Hz	7 VA				
U72	12 V DC	5 W				
G72	12 V DC	5 W				
U73	24 V DC	5 W				
G73	24 V DC	5 W				

Notes to the table:
 Sol. volt. = Solenoid voltage
 Pow. abs. = Power absorption

Mod. U7K1, G7K1, U771 and G771 are to be used only with sol. valves series A, NO in line.

Solenoids Mod. A8...



Electrical connection: bipolar plus earth
Norm: DIN EN 175 301-803-A

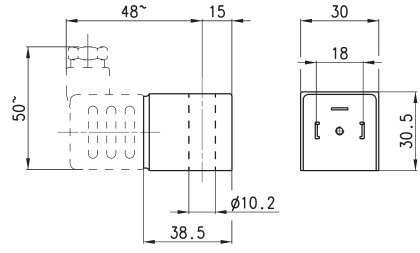

Mod.	Solenoid voltage	Power absorption
A8B	24V - 50/60Hz	5VA
A8D	110V - 50/60Hz	5VA
A8E	220V - 50/60Hz	5VA
A8S	24V DC	4W

Solenoids for solenoid valves Series A, 3, 4, 9 and NA

All solenoids presented can be mounted on the following solenoid valves: Series A - 3 - 4 - 9 - NA

NB:
For the tightening of the solenoids' nut we recommend to do it manually, avoiding the use of any equipment.

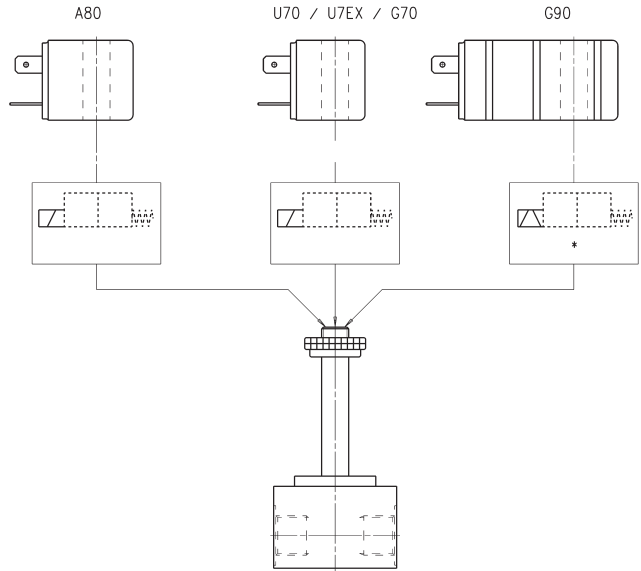

Solenoids Mod. B8...

Electrical connection: bipolar plus earth
Norm: DIN EN 175 301-803-A



Solenoid material: PA-MXD6

The B8*K models can be used only with some solenoid valves Series CFB (Mod. CFB-D1..., 2/2 NO).
Further details in the dedicated section 1.30.

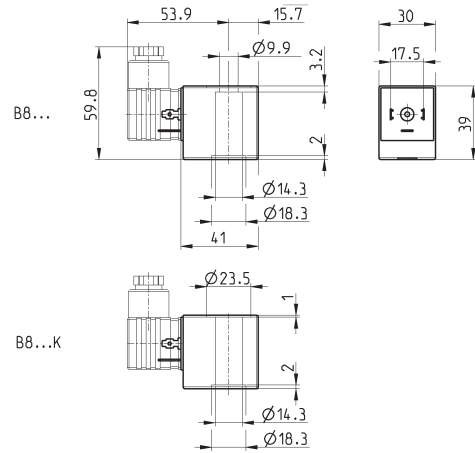

Mod.	Solenoid voltage	Power absorption
B8B	24 V - 50 Hz	15 VA
B8BK	24 V - 50 Hz	15 VA
B8D	110 V - 50/60 Hz	15 VA
B8DK	110 V - 50/60 Hz	15 VA
B8E	220/230 V - 50/60 Hz	15 VA
B8EK	230 V - 50/60 Hz	15 VA
B8F	220/230 V - 50/60 Hz	21 VA
B8FK	220/230 V - 50/60 Hz	21 VA
B8Z	12 V - DC	19 W
B8ZK	12 V - DC	19 W
B83	24 V - DC	19 W
B83K	24 V - DC	19 W

Solenoid Mod. H8.. for potentially explosive ambients



Certification in compliance with
EN 60079-0 EN 60079-18
ATEX :
II 2G Ex mb IIC T4 Gb
II 2D Ex mb IIIC T135°C Db
I M2 Ex mb I Mb
INERIS 06ATEX0002X

IECEX :
Ex mb IIC T4 Gb
Ex mb IIIC T135°C Db
Ex mb I Mb
IECEX INE 15.0053X

For Series NA use plate mod. NA54-PC.

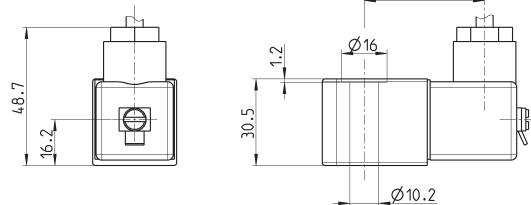
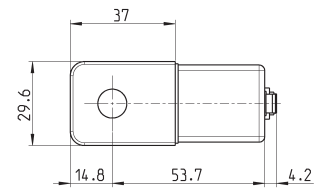

Mod.	Solenoid voltage	Power absorption
H83I	24 V - DC	5.3 W
H8BI	24 V - 50/60 Hz	5.3 W
H8CI	48 V - 50/60 Hz	5.3 W
H8DI	110 V - 50/60 Hz	5.3 W
H8EI	230 V - 50/60 Hz	5.3 W

Temperature class/Max surface temperature: T4/135°C
Environment temperature: -20°C + 40°C
Connection: tripolar cable 3 m (other lengths on request)
Incapsulating material: self-extinguishing PA.

Solenoids Mod. B9...



Electrical connection: bipolar plus earth
Norm: DIN EN 175 301-803-A

Solenoid material: PA-MXD6

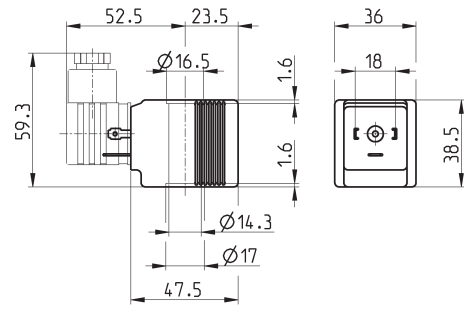

Mod.	Solenoid voltage	Power absorption
B9B	24 V - 50 Hz	29 VA
B9D	110 V - 50/60 Hz	29 VA
B9E	230 V - 50 Hz	29 VA
B9S	24 V - DC	30 W

Connectors Mod. 122-... DIN EN 175 301-803-B



For solenoids Mod. U7/U7*EX, G7 and B7

Mod. 122-800EX:
for ATEX certified solenoids mod. U7*EX, with anti-screwing off screw mod. TORX.

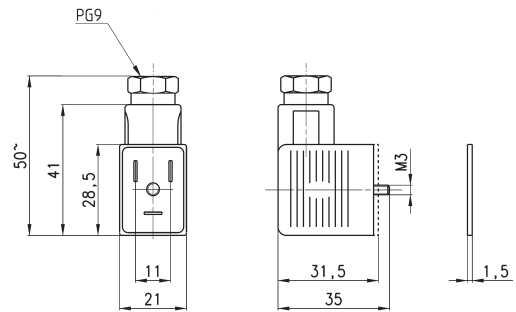

Mod.	description	colour	working voltage	cable gland	tightening torque
122-601	connector, diode + Led	transparent	10/50 V DC	PG9	0.5 Nm
122-701	connector, varistor + Led	transparent	24 V AC/DC	PG9	0.5 Nm
122-702	connector, varistor + Led	transparent	110 V AC/DC	PG9	0.5 Nm
122-703	connector, varistor + Led	transparent	230 V AC/DC	PG9	0.5 Nm
122-800	connector, without electronics	black	-	PG9	0.5 Nm
122-800EX	connector, without electronics	black	-	PG9	0.5 Nm

Connectors Mod. 122-571 DIN EN 175 301-803-B with cable

For solenoids Mod. U7, G7 and B7

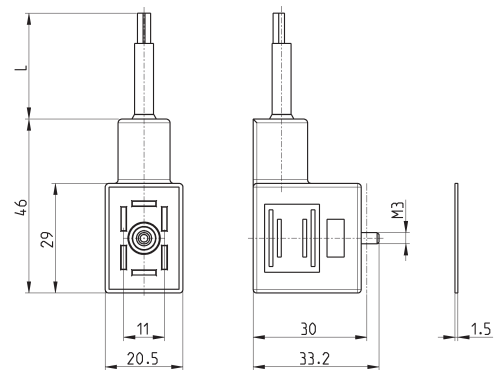

Mod.	description	colour	working voltage	cable length [L]	cable gland	tightening torque
122-571-1	moulded cable, varistor + Led	black	24 V AC/DC	1000 mm	-	0.5 Nm
122-571-2	moulded cable, varistor + Led	black	24 V AC/DC	2000 mm	-	0.5 Nm
122-571-3	moulded cable, varistor + Led	black	24 V AC/DC	3000 mm	-	0.5 Nm
122-571-5	moulded cable, varistor + Led	black	24 V AC/DC	5000 mm	-	0.5 Nm
122-571-10	moulded cable, varistor + Led	black	24 V AC/DC	10000 mm	-	0.5 Nm

Connectors Mod. 122-89*C DIN EN 175 301-803-B



For solenoids Mod. G9

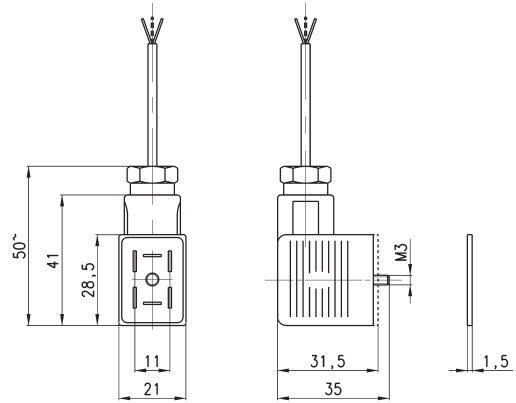

Mod.	description	colour	working voltage	cable length [L]	cable gland	tightening torque
122-892C	pre-wired connector, positive common	transparent	12/24V DC	2000 mm	PG9	0.5 Nm
122-893C	pre-wired connector, negative common	transparent	12/24V DC	2000 mm	PG9	0.5 Nm

Connector Mod. 124-... DIN EN 175 301-803-A



For solenoids Mod. A8 and Mod. B8/B9

Protection class IP65

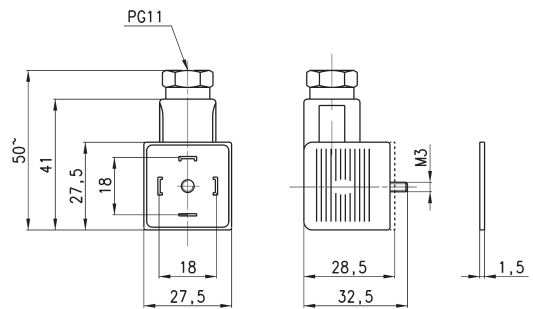

Mod.	description	colour	working voltage	cable gland	tightening torque
124-800	connector, without electronics	black	-	PG9/PG11	0.5 Nm
124-702	connector, varistor + Led	black	110 V AC/DC	PG9/PG11	0.5 Nm
124-701	connector, varistor + Led	black	24 V AC/DC	PG9/PG11	0.5 Nm
124-703	connector, varistor + Led	black	230 V AC/DC	PG9/PG11	0.5 Nm

Series VNR Unidirectional valves

Ports of Thread version: M5, G1/8, G1/4, G3/8, G1/2, G3/4, G1
Dimensions of Tube/Tube version: Ø4; Ø6; Ø8; Ø10; Ø12

SERIES VNR UNIDIRECTIONAL VALVES



- » In-line mounting thanks to integrated fittings
- » Low operating pressures
- » Robust design, brass body
- » Version 6580 and 6510 in FKM with a wide range of chemical compatibility and operating temperatures extended.
- » Version for use with oxygen available

Series VNR unidirectional valves are available in the Thread or Integrated Fitting version. Thanks to their construction they operate at low pressures.

GENERAL DATA

Valve group	automatic valves
Construction	poppet-type
Materials	brass body stainless steel spring NBR/FKM seals (for version 6580)
Mounting	in any position
Dimensions thread version	M5, G1/8, G1/4, G3/8, G1/2, G3/4, G1
Dimensions tube version	Ø4; Ø6; Ø8
Operating temperature	0 °C ÷ 80 °C; NBR (with dry air -20 / +80 °C) FKM (with dry air - 20 / +200 °C)
Medium	filtered air without lubrication. If lubricated air is used, it is recommended to use ISO VG32 oil. Once applied the lubrication should never be interrupted.

Series VNR unidirectional valves

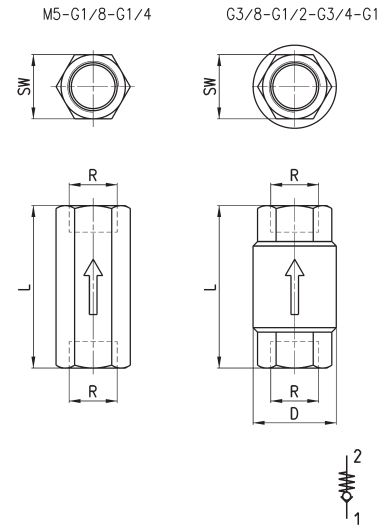

DIMENSIONS							
Mod.	R	L	SW	D	Flow 6 bar $\Delta P1$ (Nl/min)	Min. operating pressure (bar)	Max working pressure (bar)
VNR-205-M5	M5	25	8	9	50	1	10
VNR-210-1/8	G1/8	34	13	15	600	0.2	10
VNR-843-07	G1/4	43	17	20	1400	0.2	10
VNR-238-3/8	G3/8	55	23	34.5	3000	0.02	25
VNR-212-1/2	G1/2	58.5	27	34.5	5800	0.02	25
VNR-234-3/4	G3/4	65	33	41.5	8000	0.06	25
VNR-201-01	G1	74.5	40	48	13000	0.06	25

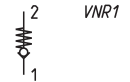

Series VNR unidirectional valves

New

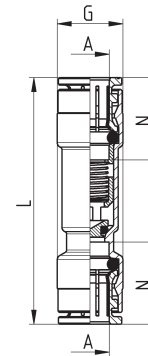

Mod.	A	G	L	N	Flow 6 bar $\Delta P1$ (Nl/min)	Min. operating pressure (bar)	Max operating pressure (bar)	Weight (g)
6580 4-VNR	4	9	40	14	85	0,5	10	13
6580 6-VNR	6	12	48	16	450	0,2	10	20
6580 8-VNR	8	14	52.5	17.5	900	0,2	10	30

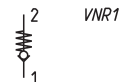

Series VNR unidirectional valves

New

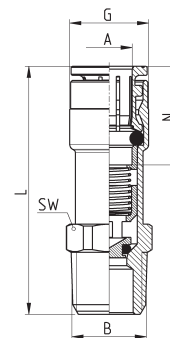

Mod.	A	B	G	L	N	SW	Flow 6 bar $\Delta P1$ (Nl/min)	Min. operating pressure (bar)	Max operating pressure (bar)	Weight (g)
VNR60 4-M5	4	M5	9	27.5	12	10	85	0.2	10	13
VNR60 6-1/8	6	R1/8	12	37.5	16	12	450	0.2	10	18
VNR60 6-1/4	6	R1/4	12	41	16	14	450	0.2	10	22
VNR60 8-1/8	8	R1/8	14	40.5	17.5	14	900	0.2	10	23
VNR60 8-1/4	8	R1/4	14	44	17.5	14	900	0.2	10	25
VNR60 4-M5-OX1*	4	M5	9	27.5	12	10	85	0.2	10	13
VNR60 6-1/8-OX1*	6	R1/8	12	37.5	16	12	450	0.2	10	18
VNR60 6-1/4-OX1*	6	R1/4	12	41	16	14	450	0.2	10	22
VNR60 8-1/8-OX1*	8	R1/8	14	40.5	17.5	14	900	0.2	10	23
VNR60 8-1/4-OX1*	8	R1/4	14	44	17.5	14	900	0.2	10	25

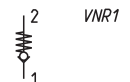

Series VNR unidirectional valves

New

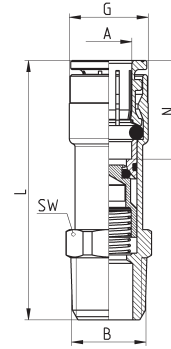

Mod.	A	B	G	L	N	SW	Flow 6 bar ΔP1 (NL/min)	Min. operating pressure (bar)	Max operating pressure (bar)	Weight (g)
VNR60 m5-4	4	M5	9	29.5	12	10	85	0.2	10	14
VNR60 1/8-6	6	R1/8	12	39.5	16	12	450	0.2	10	19
VNR60 1/4-6	6	R1/4	12	43	16	14	450	0.2	10	23
VNR60 1/8-8	8	R1/8	14	42.5	17.5	14	900	0.2	10	24
VNR60 1/4-8	8	R1/4	14	46	17.5	14	900	0.2	10	26
VNR60 M5-4-OX1*	4	M5	9	29.5	12	10	85	0.2	10	14
VNR60 1/8-6-OX1*	6	R1/8	12	39.5	16	12	450	0.2	10	19
VNR60 1/4-6-OX1*	6	R1/4	12	43	16	14	450	0.2	10	23
VNR60 8-1/8-OX1*	8	R1/8	14	42.5	17.5	14	900	0.2	10	24
VNR60 1/4-8-OX1*	8	R1/4	14	46	17.5	14	900	0.2	10	26

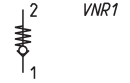

SERIES VNR UNIDIRECTIONAL VALVES

Series VSO, VSC quick exhaust valves

Series VSO ports: M5, G1/8, cartridge $\varnothing 4$

Series VSC ports: G1/8, G1/4, G1/2



- » Suitable to rapidly discharge air contained in tanks, systems or cylinder chambers.
- » Threaded versions and with fitting

Series VSC and VSO quick exhaust valves are commonly used to increase the speed of cylinders or for rapid depressurisation of tanks containing compressed air.

Mod. VSO 425-M5, VSO 426-04: they are particularly suitable to be mounted on solenoid valves and valves incorporating a $\varnothing 4$ cartridge.

Mod. VSO 4-1/8: it is particularly suitable for direct mounting on the actuator connection. The air coming in from the jointed part (1) is used by the threaded side (2), whilst the exhaust (3) passes through the holes sideways to the valve body.

Mod. VSC: they are particularly suitable to be mounted directly on the cylinder mouth through the use of a nipple. It is recommended to mount a silencer on the outlet.

GENERAL DATA

Valve group	automatic valves
Construction	poppet-type
Materials	Series VSO: brass body - NBR seals Series VSC: brass body - Desmopan seal
Mounting	in any position
Ports	Series VSO: M5, G1/8, cartridge $\varnothing 4$ Serie VSC: G1/8, G1/4, G1/2
Operating temperature	0°C ÷ 80°C (with dry air -20°C)
Fluid	filtered air, without lubrication. If lubricated air is used, it is recommended to use ISO VG32 oil. Once applied the lubrication should never be interrupted.

Quick exhaust valves Mod. VSO 425-M5, VSO 426-04

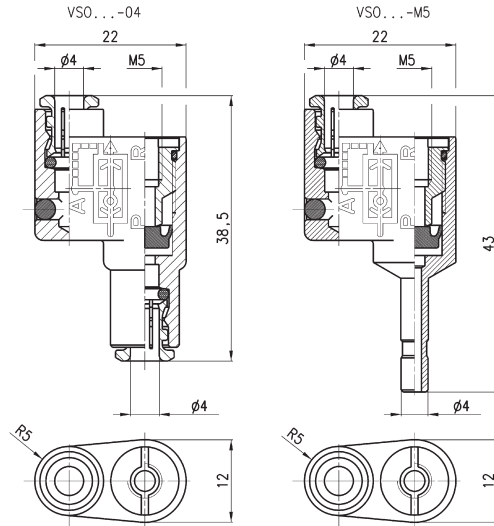
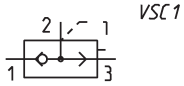

Mod.	Ports	Flow rate at 6 bar 1 > 2 (NL/min)	Flow rate at 6 bar 2 > 3 (NL/min)	Min. operating pressure (bar)	Max working pressure (bar)
VSO 425-M5	M5	50 ($\Delta P = 1$ bar)	100 ($\Delta P = 1$ bar)	1	16
VSO 426-04	cartridge $\phi 4$	50 ($\Delta P = 1$ bar)	100 ($\Delta P = 1$ bar)	1	16

Quick exhaust valve Mod. VSO 4-1/8

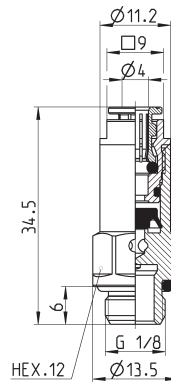
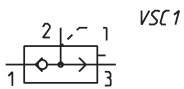

Mod.	Ports	Flow rate at 6 bar 1 > 2 (NL/min)	Flow rate at 6 bar 2 > 3 (NL/min)	Min. operating pressure (bar)	Max working pressure (bar)
VSO 4-1/8	G1/8	50 ($\Delta P = 1$ bar)	330 (free flow)	0.5	16

Series VSC quick exhaust valves

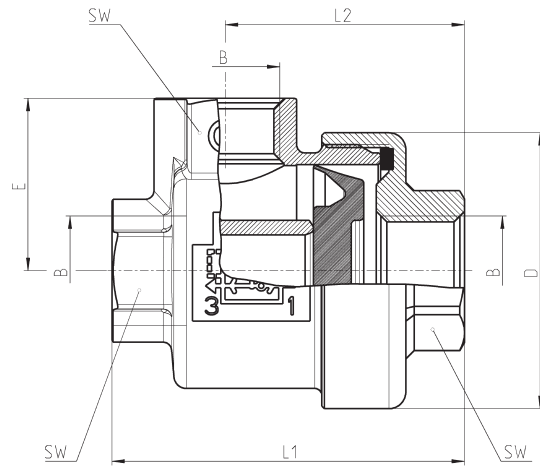
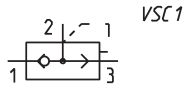

Mod.	B	D	E	L1	L2	SW	Ports	Medium inlet flow rate 1 > 2 [flow at 6 bar, ΔP 1 bar] (NL/min)	Medium exhaust flow rate 2 > 3 [flow at 6 bar, ΔP 1 bar] (NL/min)	Min. operating pressure (bar)	Max working pressure (bar)
VSC 588-1/8	1/8	28	17.5	36.5	25	14	G1/8	630	940	0.5	12
VSC 544-1/4	1/4	33	20.5	42	28.5	17	G1/4	860	1600	0.3	12
VSC 522-1/2	1/2	43	27	57.5	39.5	24	G1/2	4700	6250	0.2	12

SERIES VSO, VSC QUICK EXHAUST VALVES

Adjustable overpressure exhaust valve Mod. VMR 1/8-B10

Ports: G1/8



» Able to maintain pressure constant at a set value which allows the overpressure to exhaust

The adjustable valve Mod. VMR 1/8-B10 allows to discharge the overpressure that can be generated in a volume.

GENERAL DATA

Valve group	automatic valves
Construction	diaphragm type
Materials	brass body zinc-plated steel spring NBR seals
Mounting	in any position
Ports	G1/8
Operating temperature	-5°C ÷ 50°C (with the dew point of the fluid lower than 2°C at the min. working temperature)
Medium	filtered air, without lubrication. If lubricated air is used, it is recommended to use ISO VG32 oil. Once applied the lubrication should never be interrupted.

FLOW DIAGRAM and FUNCTIONING SCHEMES

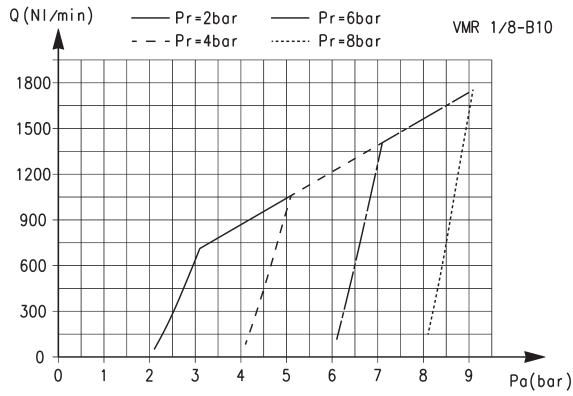

FLOW DIAGRAM

Pa = Inlet pressure
 Pr = Regulated pressure
 Q = Flow

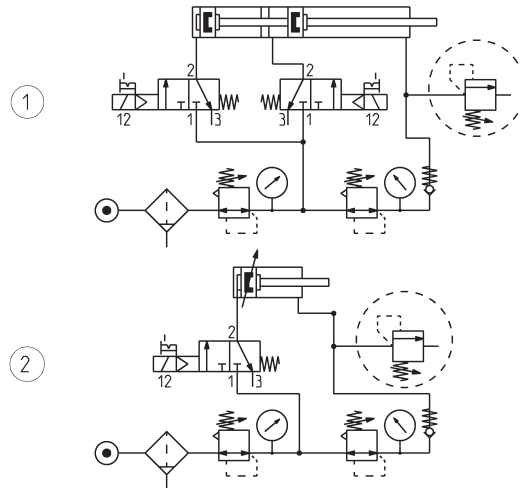

FUNCTIONING SCHEME 1: overpressure exhaust in a cylinder chamber or in a tank when the set value has been exceeded.

FUNCTIONING SCHEME 2: VMR valve with maximum adjustable pressure allows pressure in a cylinder chamber or in tank to exhaust in the atmosphere every time the set regulation value is exceeded.

ADJUSTABLE VALVE MOD. VMR 1/8-B10

Valve with maximum adjustable pressure Mod. VMR 1/8-B10

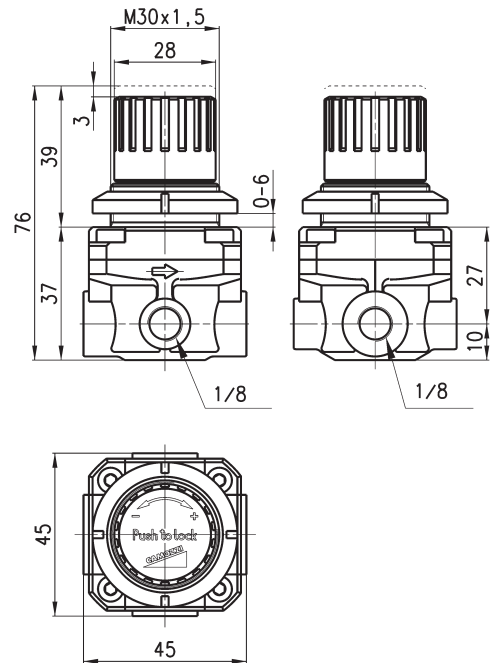
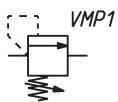

Mod.	Working pressure (bar)
VMR 1/8-B10	1 ÷ 8

Series VBO - VBU blocking valves

Unidirectional valves (VBU) and bidirectional valves (VBO)
Ports G1/8, G1/4, G3/8 and G1/2

SERIES VBO AND VBU BLOCKING VALVES



- » Series VBU: unidirectional valves with operating pressure from 0.3 to 10 bar
- » Series VBO: bidirectional valves with operating pressure from 0 to 10 bar
- » Direct mounting on cylinders or on distribution and fluid control blocks

These unidirectional and bidirectional blocking valves have been realised in order to enable mounting directly on cylinders. They can be used as high flow valves for blows, cleaning of pieces, filling of volumes. For these applications it is suggested to connect the supply to port 2 (having the male thread).

These valves can be mounted directly also on distribution and fluid control blocks.

GENERAL DATA

Construction	poppet type
Valve group	unidirectional and bidirectional blocking valve
Materials	Brass - NBR seals - stainless steel springs - PTFE
Mounting	by male thread
Ports	G1/8 - G1/4 - G3/8 - G1/2
Position	in any position
Operating temperature	0°C ÷ 80°C (with dry air -20°C)
Operating pressure	VBU: 0,3 ÷ 10 bar, VBO: 0 ÷ 10 bar
Nominal pressure	6 bar
Nominal flow	see graph
Nominal diam.	G1/8 ø 5,5 mm - G1/4 ø 8 mm - G3/8 ø 11 mm - G1/2 ø 15 mm
Fluid	filtered air, without lubrication. If lubricated air is used, it is recommended to use oil ISO VG32. Once applied, the lubrication should never be interrupted.

CODING EXAMPLE

VB	U	1/8
VB	SERIES: VB	
U	VERSIONS: U = unidirectional O = bidirectional	
1/8	PORTS: G1/8 G1/4 G3/8 G1/2	

SERIES VBO AND VBU BLOCKING VALVES

DIAGRAM OF THE PILOT PRESSURE

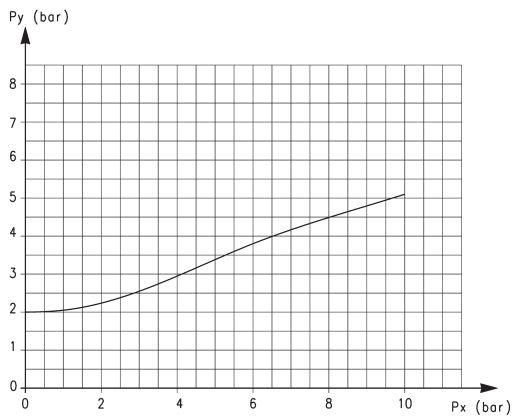

This diagram shows the relation between working pressure (Px) and pilot pressure required in order to operate the valve (Py). The opening pressure of the unidirectional valve is 0,3 bar.

FLOW DIAGRAMS OF UNIDIRECTIONAL AND BIDIRECTIONAL VALVES

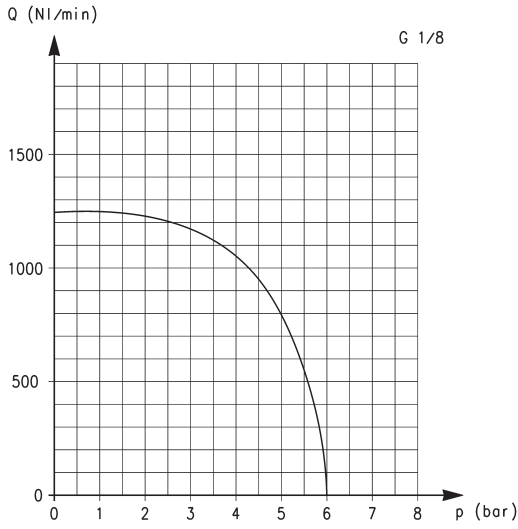

Diagram for valves VBU and VBO with G1/8 ports.

Q is the flow measured in NI/min and determined with an inlet pressure of 6 bar.

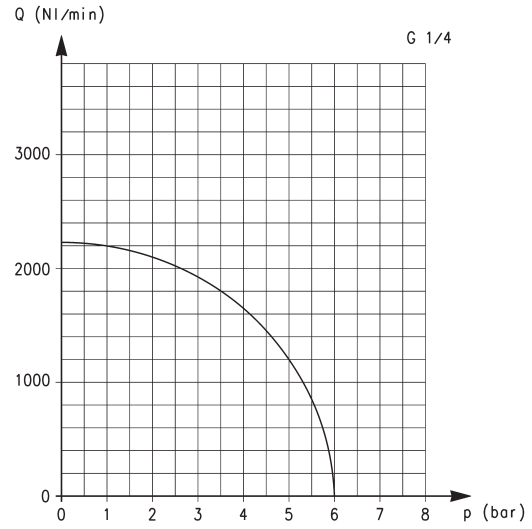

Diagram for valves VBU and VBO with G1/4 ports.

Q is the flow measured in NI/min and determined with an inlet pressure of 6 bar.

FLOW DIAGRAMS OF UNIDIRECTIONAL AND BIDIRECTIONAL VALVES

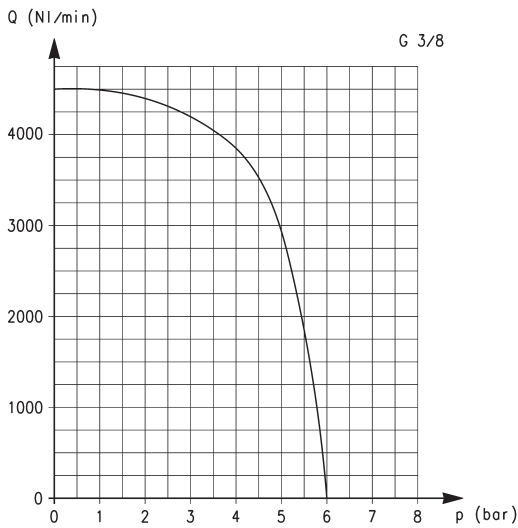

Diagram for valves VBU and VBO with G3/8 ports.

Q is the flow measured in NI/min and determined with an inlet pressure of 6 bar.

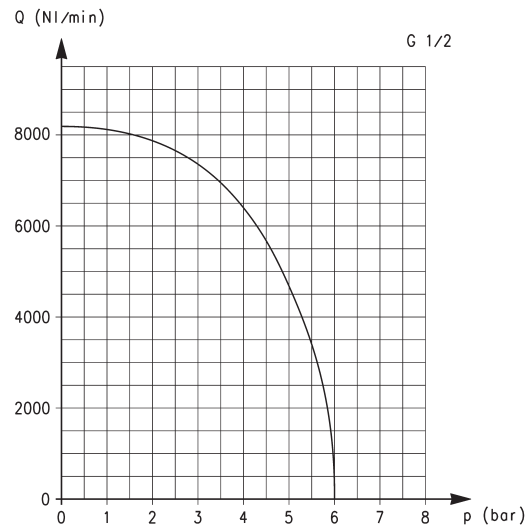
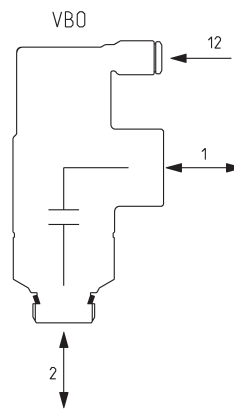
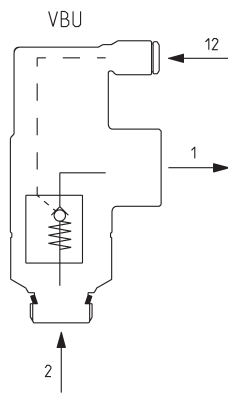
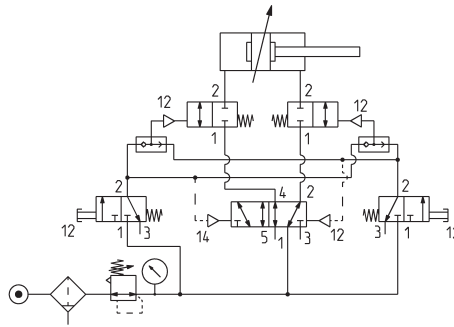
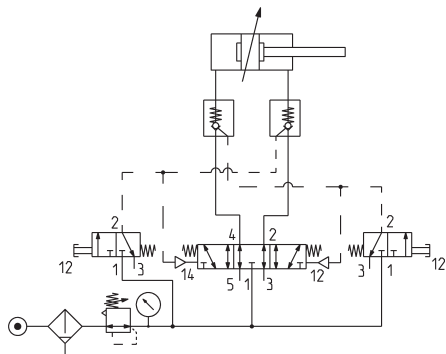
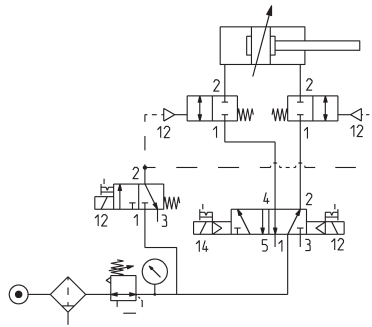
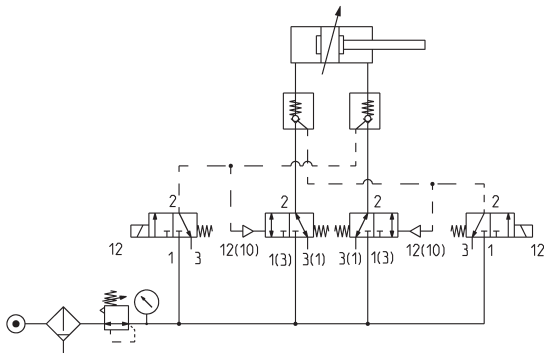

Diagram for valves VBU and VBO with G1/2 ports.

Q is the flow measured in NI/min and determined with an inlet pressure of 6 bar.

APPLICATION SCHEMES

VBU = UNIDIRECTIONAL blocking valve
VBO = BIDIRECTIONAL blocking valve



SERIES VBO AND VBU BLOCKING VALVES

Unidirectional blocking valve

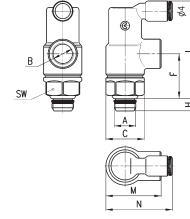

DIMENSIONS										
Mod.	A	B	C	F	H	L	M	N	SW	
VBU 1/8	1/8	1/8	16,9	20	5,5	43	24,5	30	15	
VBU 1/4	1/4	1/4	20,5	25	7	50	32,2	33,5	19	
VBU 3/8	3/8	3/8	26,8	33	8	67	40	39,5	24	
VBU 1/2	1/2	1/2	30	45,5	9	85,7	52	48	27	

Bidirectional blocking valve

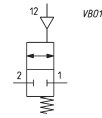
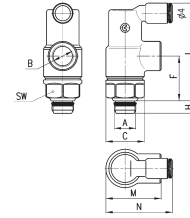

DIMENSIONS										
Mod.	A	B	C	F	H	L	M	N	SW	
VBO 1/8	1/8	1/8	16,9	20	5,5	43	24,5	30	15	
VBO 1/4	1/4	1/4	20,5	25	7	50	32,2	33,5	19	
VBO 3/8	3/8	3/8	26,8	33	8	67	40	39,5	24	
VBO 1/2	1/2	1/2	30	45,5	9	85,7	52	48	27	

Series SCU, MCU, SVU, MVU, SCO, MCO flow control valves

Unidirectional and bidirectional banjo flow control regulators

Ports: M5, G1/8, G1/4, G3/8, G1/2



These unidirectional and bidirectional flow controllers have been designed as small as possible so as to be mounted directly on valves or cylinders. The great variety of adjustable fittings makes it possible to complete the regulator with the most suitable system in relation to the available tube.

Only the G1/2 model is supplied complete with banjo flow controllers. For the other models the banjo flow controller is to be requested separately.

GENERAL DATA

Construction	needle type
Valve group	unidirectional and bidirectional controller
Materials	body and regulation screw: M5 = stainless steel; 1/8 - 1/4 - 3/8 - 1/2 = OT; seals = NBR
Mounting	by male thread
Ports	M5 - G1/8 - G1/4 - G3/8 - G1/2
Installation	in any position
Operating temperature	0°C ÷ 80°C (with dry air - 20°C)
Operating pressure	1 ÷ 10 bar
Nominal pressure	6 bar
Nominal flow	see graph
Nominal diameter	M5 = 1,5 mm - G1/8 = 2 mm - G1/4 = 4 mm - G3/8 = 7 mm - G1/2 = 12 mm
Fluid	filtered air. If lubricated air is used, it is recommended to use ISOVG 32 oil. Once applied the lubrication should never be interrupted.

Series PSCU, PMCU, PSVU, PMVU, PSCO, PMCO flow control valves

Unidirectional and bidirectional flow regulators with banjo in brass (M5) or in technopolymer (G1/8, G1/4, G3/8)
Ports: M5, G1/8, G1/4, G3/8

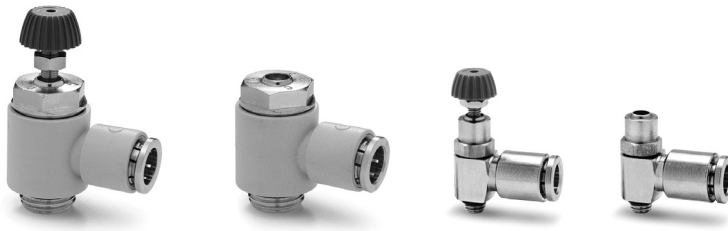

SERIES PSCU, PMCU, PSVU, PMVU, PSCO, PMCO VALVES

These unidirectional and bidirectional flow controllers have been designed as small as possible so as to be mounted directly on valves or cylinders. The great variety of adjustable fittings makes it possible to complete the regulator with the most suitable system in relation to the available tube.

All models are supplied complete with banjo flow controllers.

GENERAL DATA

Construction	needle type
Valve group	unidirectional and bidirectional controller
Materials	body, regulation screw: stainless steel (M5), brass (G1/8 - G1/4 - G3/8) collet and insert = brass banjo: brass (M5), technopolymer (G1/8 - G1/4 - G3/8) controller = technopolymer - seals = NBR
Mounting	by male thread
Ports	M5 - G1/8 - G1/4 - G3/8
Installation	in any position
Operating temperature	0°C ÷ 60°C (with dry air -20°C)
Operating pressure	1 ÷ 10 bar
Nominal pressure	6 bar
Nominal flow	see graph
Nominal diameter	M5 = 1.5 mm - G1/8 = 2 mm - G1/4 = 4 mm - G3/8 = 7 mm
Fluid	filtered air. If lubricated air is used, it is recommended to use ISOVG 32 oil. Once applied the lubrication should never be interrupted.

Series TMCU, TMVU, TMCO flow control valves

Unidirectional and bidirectional banjo flow controllers with nominal diameter 2 - 3,8 - 5,8 - 8 mm
Ports: G1/8, G1/4, G3/8, G1/2



Series TMCU, TMVU, TMCO unidirectional and bidirectional flow controllers have been revised in order to decrease their dimensions and improve their flow rate characteristics. Their construction allows for easy assembly to cylinders and valves and allows the regulation adjustment to be precise and gradual.

GENERAL DATA

Construction	needle - type
Valve group	unidirectional and bidirectional controller
Materials	brass - technopolymer - NBR
Mounting	by male threaded
Threaded ports	G1/8 - G1/4 - G3/8 - G1/2
Installation	in any position
Operating temperature	0°C ÷ 60°C (with dry air -20°C)
Operating pressure	0,5 ÷ 10 bar
Nominal pressure	6 bar
Nominal flow	see graph
Nominal dia.	Tube 4 Ø2 - Tube 6 Ø3,8 - Tube 8 Ø5,8 - Tube 10 and 12 Ø8
Fluid	filtered air. If lubricated air is used, it is recommended to use ISOVG 32 oil. Once applied the lubrication should never be interrupted.

Series GSCU, GMCU, GSVU, GMVU, GSCO, GMCO flow control valves

Unidirectional and bidirectional banjo flow controllers with nominal diameter 1,5 - 3,5 - 5 mm
Ports: M5, G1/8 and G1/4



These unidirectional and bidirectional flow controllers have been designed as small as possible to enable mounting directly on valves or cylinders. The flow regulation range is wide and gradual, allowing the regulation to be very accurate either at minimum or maximum flow.

GENERAL DATA

Construction	needle - type
Valve group	unidirectional and bidirectional controller
Materials	body and screws M5 inox; 1/8 - 1/4 - 3/8 - 1/2 OT58 seals NBR
Mounting	by male threaded
Installation	in any position
Operating temperature	0°C ÷ 80°C (with dry air -20°C)
Operating pressure	1 ÷ 10 bar
Nominal pressure	6 bar
Nominal flow	see graph
Nominal diameter	M5 = 1.5 mm - G1/8 = 2 mm - G1/4 = 4 mm G3/8 = 7 mm - G1/2 = 12 mm
Fluid	filtered air. If lubricated air is used, it is recommended to use ISOVG 32 oil. Once applied the lubrication should never be interrupted.

Series AP directly operated proportional valves

2/2-way proportional valves, NC
Sizes: 16 - 22 mm



- » PWM or current operation
 - » Open loop flow control
 - » Also suitable for use with vacuum
- Several versions available:
- » with body in PVDF (size 16mm only),
 - » with rear flanged bodies
 - » with lower flanged bodies,
 - » suitable for use with oxygen
 - » Seals in FKM, NBR and EPDM

Series AP directly operated 2/2-way proportional solenoid valves, NC, with nominal diameters range from 0.8 to 2.4 mm, can be used where an open loop flow control is required, with gas mixtures, to control free flows or blows, or emptying chambers using vacuum.

Series AP proportional valves have been manufactured to optimize and reduce friction and stick-slip effects. The output flow is proportional to the control signal. As they can work also in vacuum, a minimum working pressure is not required.

GENERAL DATA

Function	2/2 NC			
Operation	proportional directly operated			
Ports	M5 - G1/8 - with rear flanges - with lower flanges			
Hysteresis	Size 16mm: 12% FS		Size 22mm: 10% FS	
Repeatability	Size 16mm: 7% FS		Size 22mm: 7% FS	
Operating temperature	0 ÷ 60°C			
Medium	filtered compressed air, unlubricated, according to ISO 8573-1 class 3.4.3, inert gas. All the valves are suitable for use with oxygen.			
Installation	any position			
Materials	body = brass / PVDF (size 16mm only) seals = NBR, FKM, EPDM			
Nominal resistance	GP7	GPH	U711	U712
Rated current	193 mA	250 mA	271 mA	542 mA

NOTE: Having a counterpressure on the outlet connection of at least 25% of the inlet pressure ensures the good functioning of the valve and improves its performance. Example: with inlet Pressure = 1 bar on the outlet connection, a min. counterpressure of 250 mbar is recommended.

CODING EXAMPLE

AP - 7 2 1 1 - L R 2 - U 7 11 OX2

AP	SERIES		
7	BODY: 6 = size 16mm 7 = size 22mm		
2	NUMBER OF WAYS: 2 = 2-way		
1	VALVE FUNCTION: 1 = NC		
1	PORTS: 0 = M5 (size 16mm only) 1 = G1/8 (size 22mm only)	4 = with rear flanges (size 16mm only) 5 = with lower flanges	L = male hose adaptor (for body in PVDF only, size 16mm)
L	ORIFICE: D = \varnothing 0.8 mm (size 16mm only) F = \varnothing 1 mm	H = \varnothing 1.2 mm L = \varnothing 1.6 mm	N = \varnothing 2 mm (size 22mm only) Q = \varnothing 2.4 mm (size 22mm only)
R	SEAL MATERIAL: R = NBR	W = FKM	E = EPDM
2	BODY MATERIAL: 2 = brass 3 = PVDF (size 16mm only)		
U	ENCAPSULATING MATERIAL: G = PA (size 16mm only) U = PET (size 22mm only)		
7	SOLENOID DIMENSIONS: P = 16x26 DIN EN 175301-803-C (size 16mm only) 7 = 22x22 DIN 43650 B (size 22mm only)		
11	SOLENOID VOLTAGE: H = 12 V DC 3 W (size 16mm only) 7 = 24 V DC 3 W (size 16mm only) 11 = 24 V DC 6.5 W (size 22mm only) 12 = 12 V DC 6.5 W (size 22mm only)		
	COIL ORIENTATION: = fastons opposite to pneumatic ports/same side of the outlet 5 = fastons towards pneumatic ports/same side of the inlet		
OX2	VERSION: OX2 = version with ASTM G93-03 Certification Level B (FKM seals only) = non-certified version		

SERIES AP PROPORTIONAL VALVES

FLOW GRAPH

Flow characteristic curve of a proportional valve

Q = flow
D.C. = duty cycle

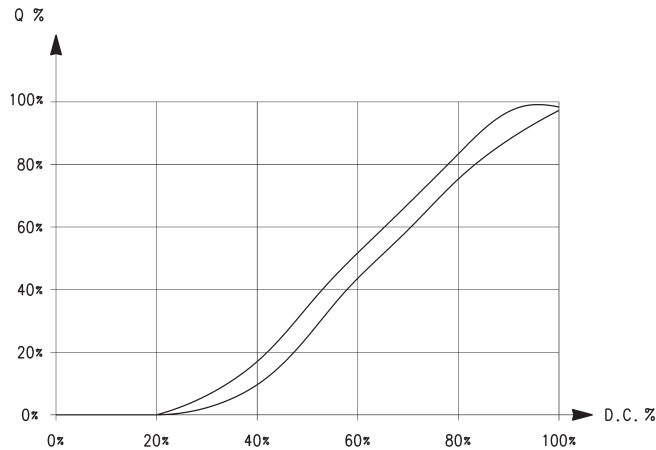

FLOW DIAGRAMS - size 16mm

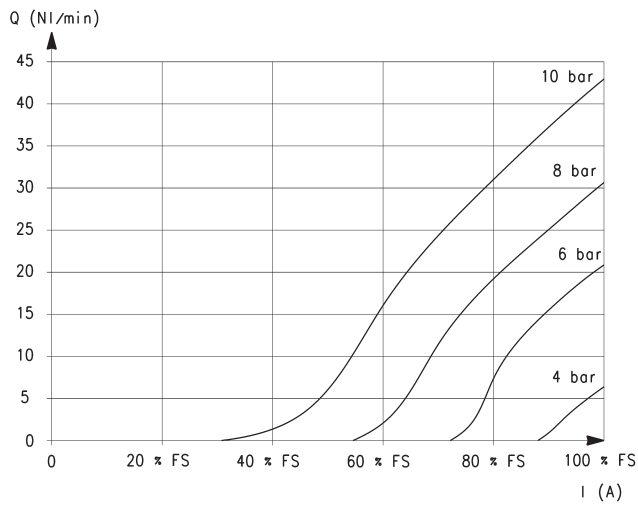

Nozzle 0.8mm

Q = Flow (NL/min)
I = Current (A)
FS = Full scale

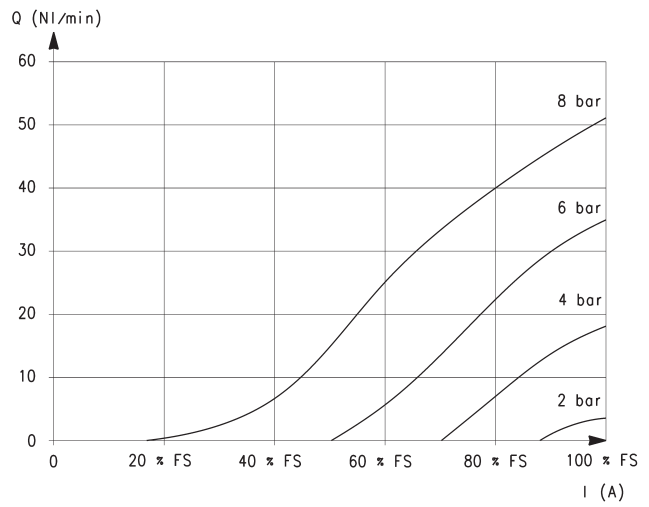

Nozzle 1mm

Q = Flow (NL/min)
I = Current (A)
FS = Full scale

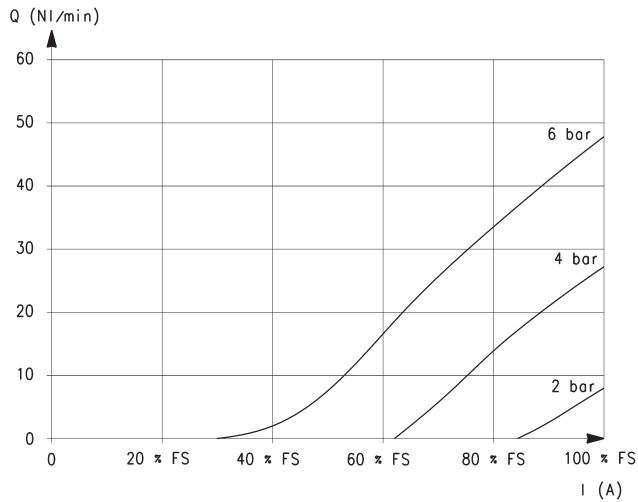

Nozzle 1.2mm

Q = Flow (NL/min)
I = Current (A)
FS = Full scale

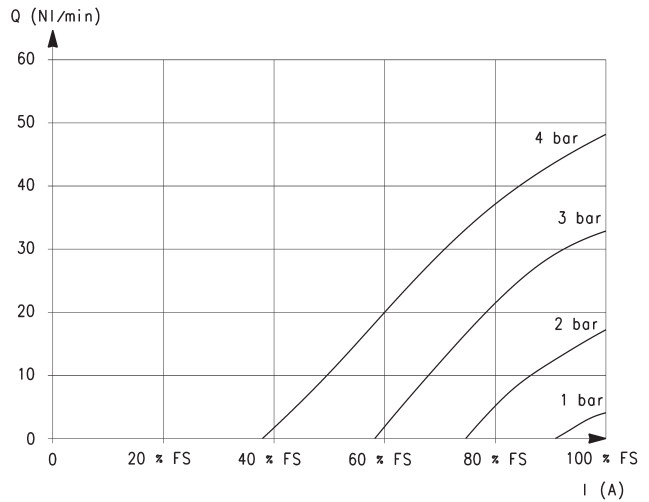

Nozzle 1.6mm

Q = Flow (NL/min)
I = Current (A)
FS = Full scale

FLOW DIAGRAMS - size 22mm

SERIES AP PROPORTIONAL VALVES

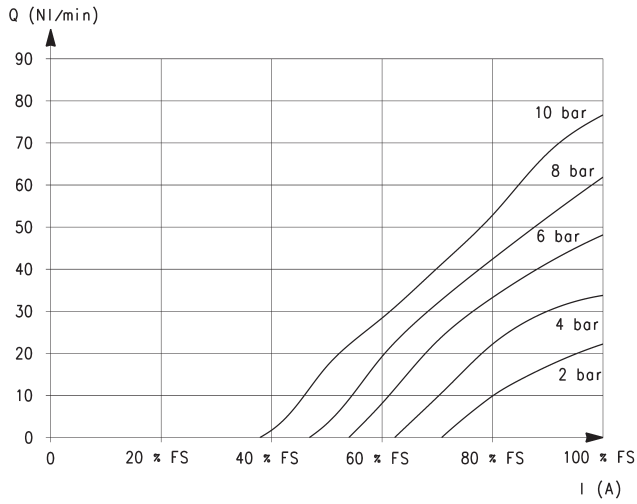

Nozzle 1mm

Q = Flow (NL/min)
I = Current (A)
FS = Full scale

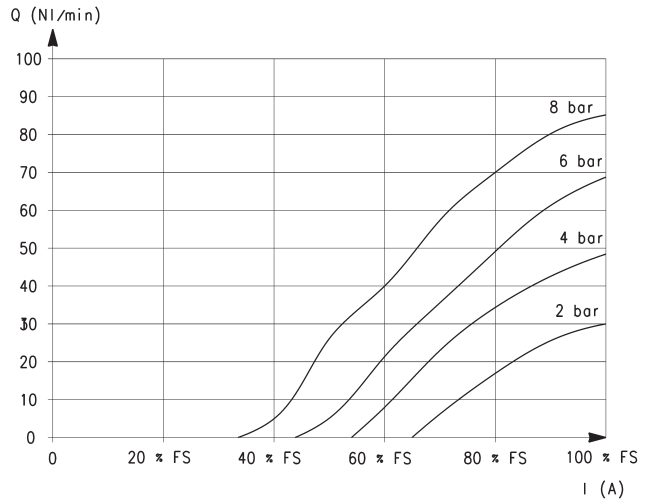

Nozzle 1.2mm

Q = Flow (NL/min)
I = Current (A)
FS = Full scale

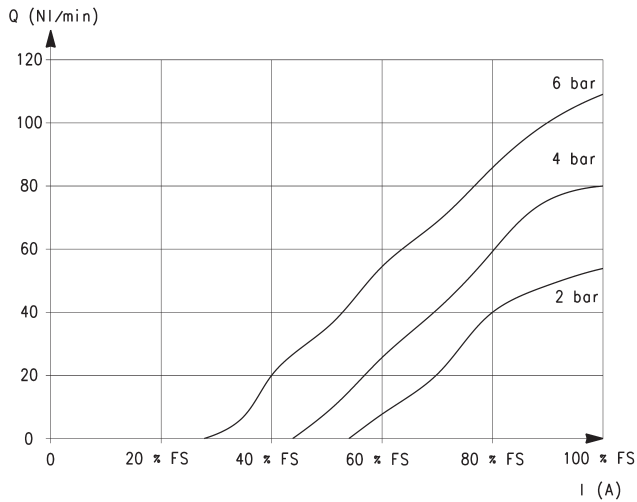

Nozzle 1.6mm

Q = Flow (NL/min)
I = Current (A)
FS = Full scale

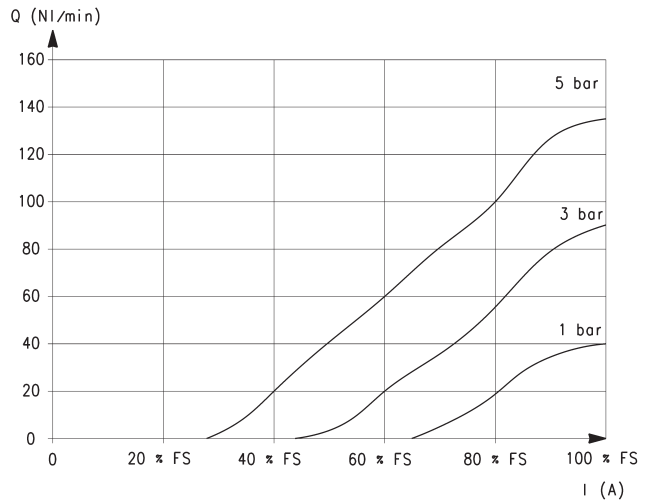

Nozzle 2mm

Q = Flow (NL/min)
I = Current (A)
FS = Full scale

FLOW DIAGRAM - size 22mm

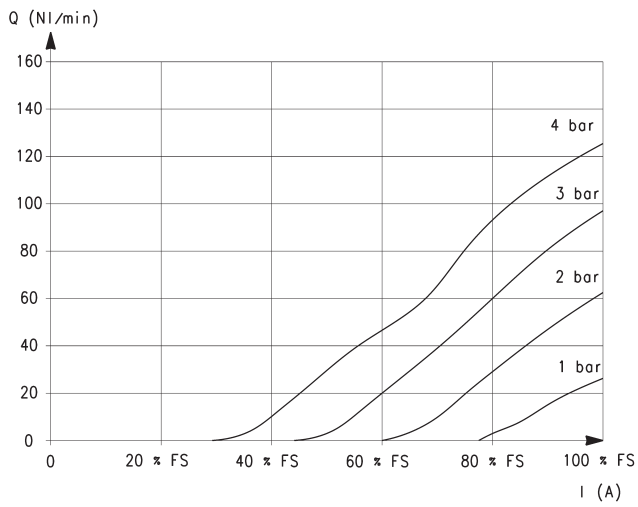

Nozzle 2.4mm

Q = Flow (NL/min)

I = Current (A)

FS = Full scale

MAXIMUM FLOW AND RESPONSE TIMES - size 16mm

Maximum flow according to the set pressure, for each orifice.

DIAGRAM LEGEND:

Q = flow (NL/min)
P = set pressure (bar)

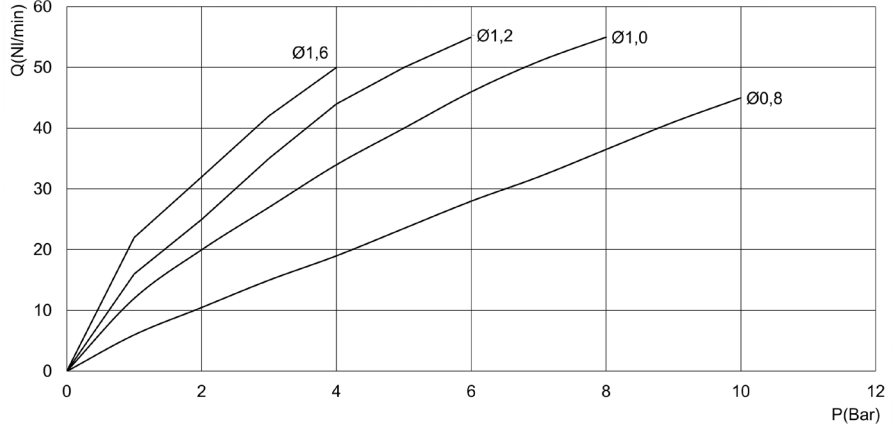

RESPONSE TIMES calculated according to the maximum flow at each operating pressure. [Electromechanical response time: 10 ms]

ø	Pin [bar]	Load response time [ms]			Exhaust response time [ms]		
		0% - 10%	0% - 90%	10% - 90%	100% - 90%	100% - 10%	90% - 10%
0.8 mm	10	12	43	31	11	39	28
1 mm	8	12	42	30	11	38	27
1.2 mm	6	10	41	31	11	41	30
1.6 mm	4	10	40	30	11	40	29

MAXIMUM FLOW AND RESPONSE TIMES - size 22mm

Maximum flow according to the set pressure, for each orifice.

DIAGRAM LEGEND:

Q = flow (NL/min)
P = set pressure (bar)

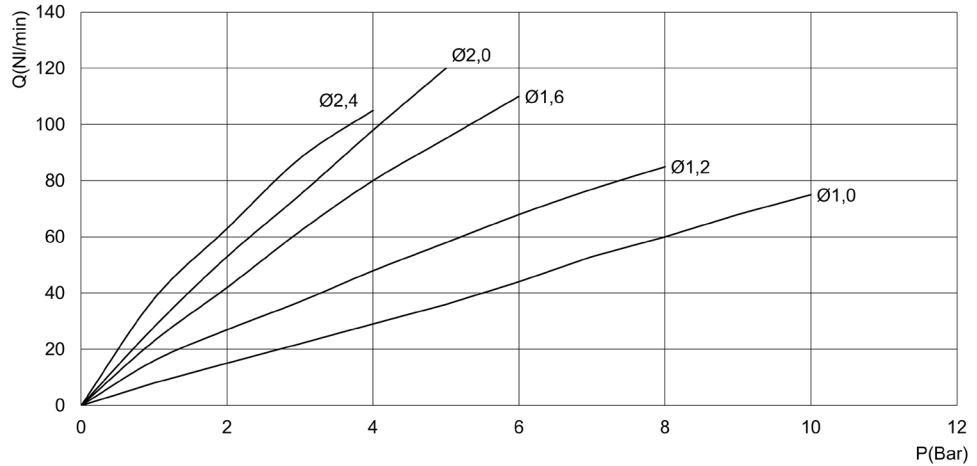

RESPONSE TIMES calculated according to the maximum flow at each operating pressure. [Electromechanical response time: 10 ms]

ø	Pin [bar]	Load response time [ms]			Exhaust response time [ms]		
		0% - 10%	0% - 90%	10% - 90%	100% - 90%	100% - 10%	90% - 10%
1 mm	10	10	36	26	10	36	26
1.2 mm	8	10	45	35	12	38	26
1.6 mm	6	12	45	33	12	40	28
2 mm	5	12	42	30	11	34	26
2.4 mm	4	11	45	34	12	44	32

Series AP proportional valves - 22mm, body with threaded ports



For the use with vacuum connect the line to port 2.

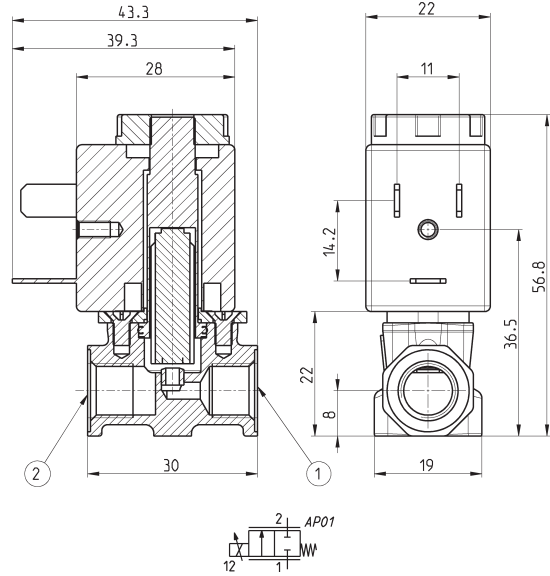
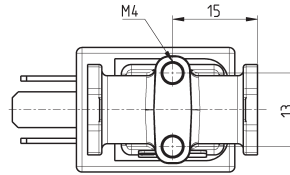

Mod.	Port 1	Port 2	Function	Orifice Ø (mm)	kv (l/min)	Max pressure (bar)	Max flow (NL/min)
AP-7211-FR2-U7*	G1/8	G1/8	2/2 NC	1	0.5	10	75
AP-7211-HR2-U7*	G1/8	G1/8	2/2 NC	1.2	0.7	8	85
AP-7211-LR2-U7*	G1/8	G1/8	2/2 NC	1.6	1.2	6	110
AP-7211-NR2-U7*	G1/8	G1/8	2/2 NC	2	1.7	5	135
AP-7211-QR2-U7*	G1/8	G1/8	2/2 NC	2.4	1.7	4	113
AP-7211-FW2-U7*OX2	G1/8	G1/8	2/2 NC	1	0.5	10	75
AP-7211-HW2-U7*OX2	G1/8	G1/8	2/2 NC	1.2	0.7	8	85
AP-7211-LW2-U7*OX2	G1/8	G1/8	2/2 NC	1.6	1.2	6	110
AP-7211-NW2-U7*OX2	G1/8	G1/8	2/2 NC	2	1.7	5	135
AP-7211-QW2-U7*OX2	G1/8	G1/8	2/2 NC	2.4	1.7	4	113

* choose the desired voltage

Series AP proportional valves - size 22mm, low flanged body



For the use with vacuum connect the line to port 2.

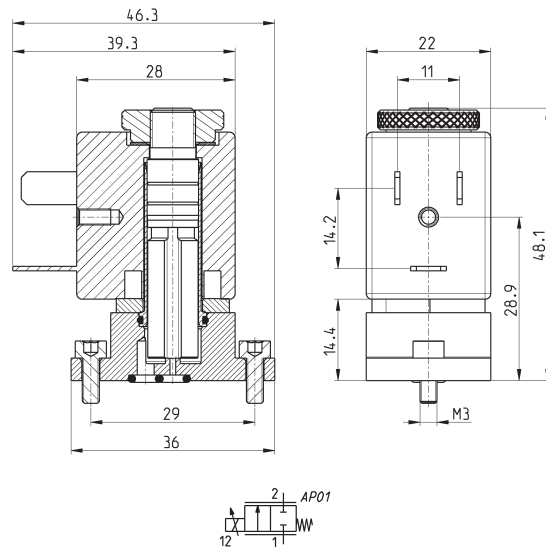
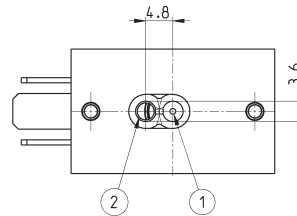

Mod.	Function	Orifice Ø (mm)	kv (l/min)	Max pressure (bar)	Max flow (NL/min)
AP-7215-FR2-U7*	2/2 NC	1	0.5	10	75
AP-7215-HR2-U7*	2/2 NC	1.2	0.7	8	85
AP-7215-LR2-U7*	2/2 NC	1.6	1.2	6	110
AP-7215-NR2-U7*	2/2 NC	2	1.7	5	135
AP-7215-QR2-U7*	2/2 NC	2.4	1.7	4	113
AP-7215-FW2-U7*OX2	2/2 NC	1	0.5	10	75
AP-7215-HW2-U7*OX2	2/2 NC	1.2	0.7	8	85
AP-7215-LW2-U7*OX2	2/2 NC	1.6	1.2	6	110
AP-7215-NW2-U7*OX2	2/2 NC	2	1.7	5	135
AP-7215-QW2-U7*OX2	2/2 NC	2.4	1.7	4	113

* choose the desired voltage

Series AP proportional valves - 16mm, body with threaded ports



For the use with vacuum connect the line to port 2.

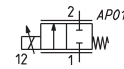
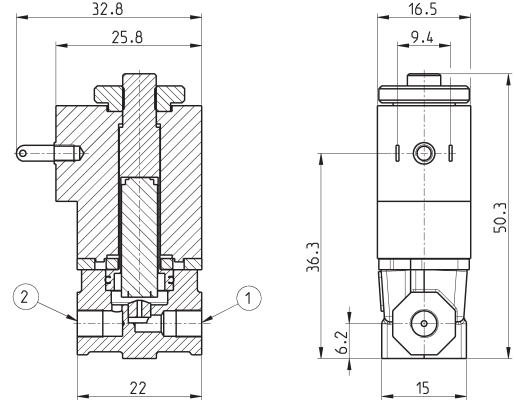
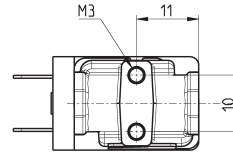

* choose the desired voltage

Mod.	Port 1	Port 2	Function	Orifice Ø (mm)	kv (l/min)	Max pressure (bar)	Max flow (NI/min)
AP-6210-DR2-GP*	M5	M5	2/2 NC	0.8	0.3	10	43
AP-6210-FR2-GP*	M5	M5	2/2 NC	1	0.45	8	53
AP-6210-HR2-GP*	M5	M5	2/2 NC	1.2	0.57	6	53
AP-6210-LR2-GP*	M5	M5	2/2 NC	1.6	0.78	4	52
AP-6210-DW2-GP*OX2	M5	M5	2/2 NC	0.8	0.3	10	43
AP-6210-FW2-GP*OX2	M5	M5	2/2 NC	1	0.45	8	53
AP-6210-HW2-GP*OX2	M5	M5	2/2 NC	1.2	0.57	6	53
AP-6210-LW2-GP*OX2	M5	M5	2/2 NC	1.6	0.78	4	52

Series AP proportional valves - 16mm, low flanged body

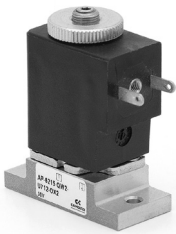

For the use with vacuum connect the line to port 2.

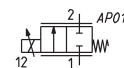
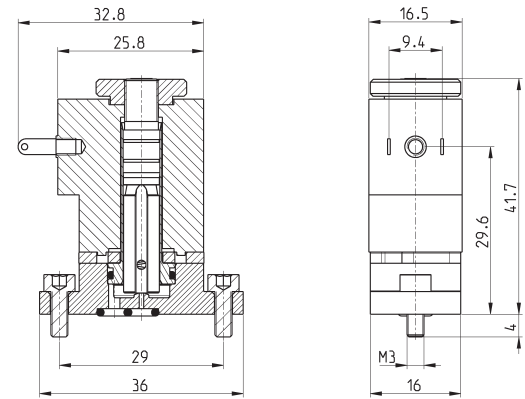
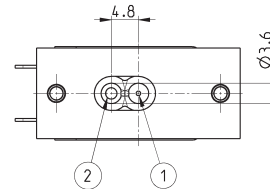

* choose the desired voltage

Mod.	Function	Orifice Ø (mm)	kv (l/min)	Max pressure (bar)	Max flow (NI/min)
AP-6215-DR2-GP*	2/2 NC	0.8	0.3	10	43
AP-6215-FR2-GP*	2/2 NC	1	0.45	8	53
AP-6215-HR2-GP*	2/2 NC	1.2	0.57	6	53
AP-6215-LR2-GP*	2/2 NC	1.6	0.78	4	52
AP-6215-DW2-GP*OX2	2/2 NC	0.8	0.3	10	43
AP-6215-FW2-GP*OX2	2/2 NC	1	0.45	8	53
AP-6215-HW2-GP*OX2	2/2 NC	1.2	0.57	6	53
AP-6215-LW2-GP*OX2	2/2 NC	1.6	0.78	4	52

Series AP proportional valves - 16mm, rear flanged body



For the use with vacuum connect the line to port 2.

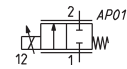
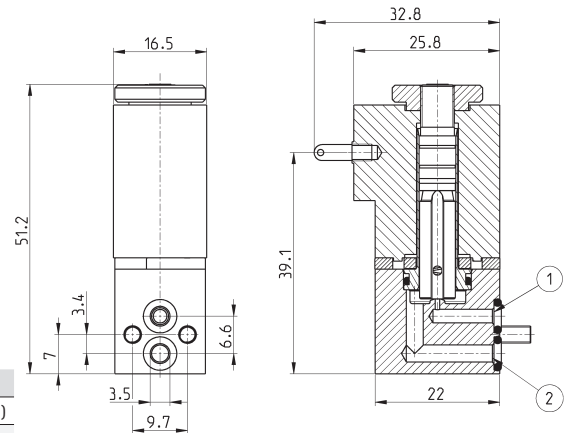
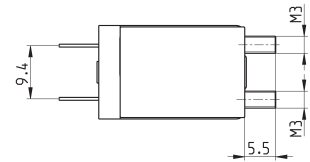

* choose the desired voltage

Mod.	Function	Orifice Ø (mm)	kv (l/min)	Max pressure (bar)	Max flow (NI/min)
AP-6214-DR2-GP*	2/2 NC	0.8	0.3	10	43
AP-6214-FR2-GP*	2/2 NC	1	0.45	8	53
AP-6214-HR2-GP*	2/2 NC	1.2	0.57	6	53
AP-6214-LR2-GP*	2/2 NC	1.6	0.78	4	52
AP-6214-DW2-GP*OX2	2/2 NC	0.8	0.3	10	43
AP-6214-FW2-GP*OX2	2/2 NC	1	0.45	8	53
AP-6214-HW2-GP*OX2	2/2 NC	1.2	0.57	6	53
AP-6214-LW2-GP*OX2	2/2 NC	1.6	0.78	4	52

Series AP proportional valves, size 16mm - body in PVDF



For the use with vacuum connect the line to port 2.

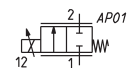
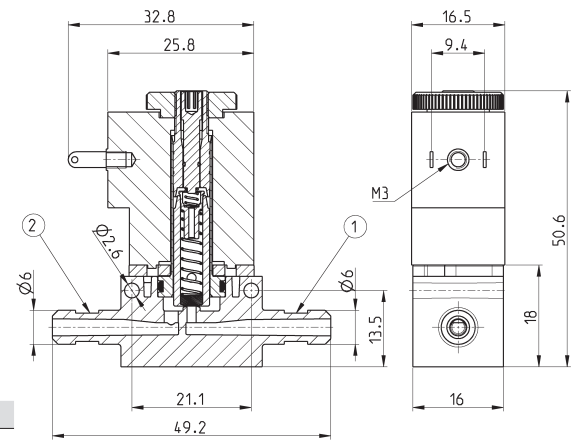
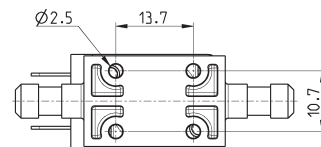

* choose the desired voltage
** pneumatic connection with tube and clamps

Mod.	Port 1	Port 2	Function	Orifice Ø (mm)	kv (l/min)	Max pressure (bar)	Max flow (NI/min)
AP-6211-DR3-GP*	Ø6 **	Ø6 **	2/2 NC	0.8	0.3	10	43
AP-6211-FR3-GP*	Ø6 **	Ø6 **	2/2 NC	1	0.45	8	53
AP-6211-HR3-GP*	Ø6 **	Ø6 **	2/2 NC	1.2	0.57	6	53
AP-6211-LR3-GP*	Ø6 **	Ø6 **	2/2 NC	1.6	0.78	4	52
AP-6211-DW3-U7*OX2	Ø6 **	Ø6 **	2/2 NC	0.8	0.3	10	43
AP-6211-FW3-U7*OX2	Ø6 **	Ø6 **	2/2 NC	1	0.45	8	53
AP-6211-HW3-U7*OX2	Ø6 **	Ø6 **	2/2 NC	1.2	0.57	6	53
AP-6211-LW3-U7*OX2	Ø6 **	Ø6 **	2/2 NC	1.6	0.78	4	52

Connector Mod. 125-800 DIN 43650 pitch 9.4 mm

For size 16 mm only

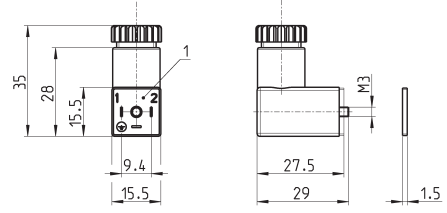

Mod.	description	colour	working voltage	cable gland	tightening torque
125-800	connector, without electronics	black	-	PG7	0.3 Nm

1 = 90° adjustable connector

Connector Mod. 125-550- DIN 43650 pitch 9.4 mm with cable

For size 16 mm only

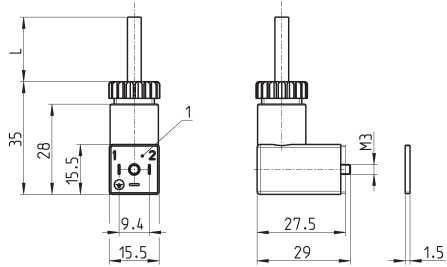

Mod.	description	colour	working voltage	cable length [L]	cable gland	tightening torque
125-550-1	moulded cable, without electronics	black	-	1000 mm	-	0.3 Nm

1 = 90° adjustable connector

In-line connectors with cable Mod. 125-553

For size 16 mm only

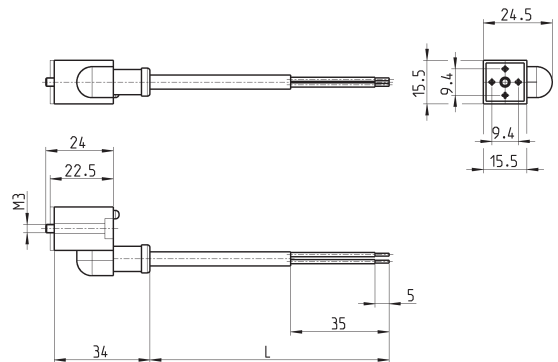

Mod.	description	colour	working voltage	cable length [L]	cable gland	tightening torque
125-553-2	in-line moulded cable, without electronics	black	-	2000 mm	-	0.3 Nm
125-553-5	in-line moulded cable, without electronics	black	-	5000 mm	-	0.3 Nm

Connectors Mod. 122-800 DIN 43650



For size 22 mm only

Mod. 122-800EX:
for ATEX certified solenoids Mod. U7*EX,
with anti-screwing off screw Mod. TORX.

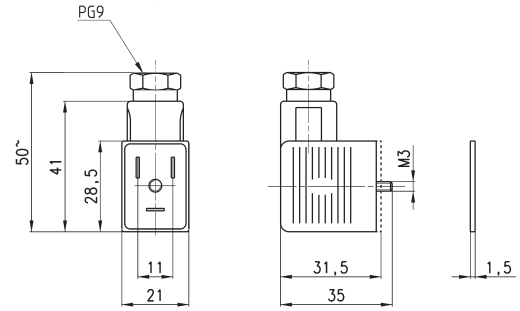

Mod.	description	colour	working voltage	cable gland	tightening torque
122-800	connector, without electronics	black	-	PG9	0.5 Nm
122-800EX	connector, without electronics	black	-	PG9	0.5 Nm

Connectors Mod. 122-550 DIN 43650 with cable

For size 22 mm only

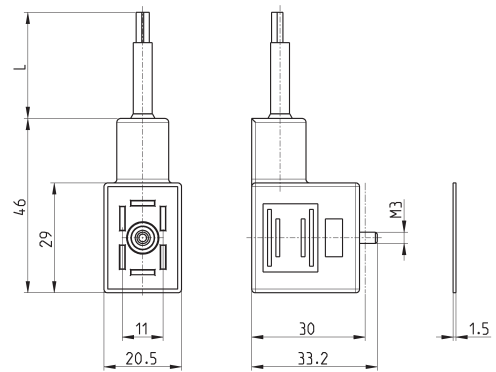

Mod.	description	colour	working voltage	cable length [L]	cable gland	tightening torque
122-550-1	moulded cable, without electronics	black	-	1000 mm	-	0.5 Nm
122-550-5	moulded cable, without electronics	black	-	5000 mm	-	0.5 Nm

Series CP directly operated and pressure compensated proportional solenoid valves

Function: 2/2-way NC
Sizes: 16 and 20 mm



- » High flow and great precision
- » Low hysteresis
- » Cartridge body
- » Pressure compensated version available
- » Suitable to work also with oxygen

Series CP directly operated proportional solenoid valves can be used where an open loop flow control is required, with gas mixtures or to control flows. Their cartridge design makes them particularly compact, thus they can be mounted directly near the workstation.

Series CP valves have been designed to optimize dimensions and reduce friction and stick-slip effects. The output flow is proportional to the control signal. Apart from the pressure compensated version, these valves can work also in vacuum. A minimum working pressure is thus not required.

GENERAL DATA

TECHNICAL FEATURES	Size 16mm, 2/2 NC	Size 16mm, 2/2 NC pressure compensated	Size 20mm, 2/2 NC	Size 20mm, 2/2 NC pressure compensated
Operation	proportional directly operated	proportional pressure compensated	proportional directly operated	proportional pressure compensated
Pneumatic connections	cartridge	cartridge	cartridge	cartridge
Nominal diameters	1 mm - 1.5 mm - 2 mm	4.4 mm	3 mm - 3.5 mm	4.4 mm
Free flow capacity	70 l/min - 80 l/min - 90 l/min	120 l/min	130 l/min - 150 l/min	200 l/min
Operating pressure	3 bar - 5 bar - 8 bar	2 bar (max pressure 7 bar)	2.8 bar - 2 bar	2.8 bar (max pressure 6 bar)
Max overpressure	16 bar	10 bar	16 bar	16 bar
Linearity (5-95%)	3% FS	<7% FS	5% FS	2% FS
Hysteresis	10% FS	<20% FS	15% FS	15% FS
Repeatability	5% FS	<5% FS	5% FS	5% FS
Operating temperature	10°C ÷ 50°C	10°C ÷ 50°C	10°C ÷ 50°C	10°C ÷ 50°C
Media	filtered compressed air, unlubricated, according to ISO 8573-1 class 7.4.4, inert gas.	filtered compressed air, unlubricated, according to ISO 8573-1 class 7.4.4, inert gas.	filtered compressed air, unlubricated, according to ISO 8573-1 class 7.4.4, inert gas.	filtered compressed air, unlubricated, according to ISO 8573-1 class 7.4.4, inert gas.
Installation	in any position	in any position	in any position	in any position
MATERIALS IN CONTACT WITH THE MEDIUM				
Body	brass, stainless steel, PPS	stainless steel, PPS	brass, stainless steel, PPS	brass, stainless steel, PPS
Seals	FKM	FKM (FDA, BAM)	FKM	FKM
ELECTRICAL FEATURES				
Operation	PWM > 1000 Hz or current control	PWM > 1000 Hz or current control	PWM > 500 Hz or current control	PWM > 1000 Hz or current control
Operation voltage	6 V DC, 12 V DC, 24 V DC	6 V DC, 12 V DC, 24 V DC	6 V DC, 12 V DC, 24 V DC	6 V DC, 12 V DC, 24 V DC
Max power consumption	3.1 W	3 W (Nominal power 2 W)	3.7 W	4.2 W
Nominal resistance	11.8 Ohm - 37.6 Ohm - 184.7 Ohm	11.8 Ohm - 47.7 Ohm - 184.7 Ohm	6.4 Ohm - 25.1 Ohm - 102.1 Ohm	6.4 Ohm - 25.1 Ohm - 102.1 Ohm
Rated current	410 mA, 238 mA, 103 mA	410 mA, 205 mA, 103 mA	615 mA, 313 mA, 154 mA	700 mA, 350 mA, 175 mA
Duty cycle	100% with air flow	100% with air flow	100% with air flow	100% with air flow
Electrical connection	cable 300mm AWG24	cable 300 mm AWG 24	cable 300mm AWG24	cable 300mm AWG24
Protection class	IP00 / IP40	IP00 / IP40	IP00 / IP40	IP00 / IP40
Average lifecycles	50000000	50000000	50000000	50000000
Command signal	recommended PWM: 1000 Hz	recommended PWM: 1000 Hz	recommended PWM: 500 Hz	recommended PWM: 1000 Hz

Versions available on demand base with 1/8, 1/4 ports

CODING EXAMPLE

CP	-	C	6	2	1	-	G	W	2	-	0	P	3
-----------	----------	----------	----------	----------	----------	----------	----------	----------	----------	----------	----------	----------	----------

CP	SERIES		
C	PORTS: C = cartridge S = subbase		
6	BODY SIZE: 6 = size 16mm 7 = size 20mm	8 = size 16 pressure compensated 9 = size 20 pressure compensated	
2	NUMBER OF PORTS: 2 = 2-way		
1	FUNCTION: 1 = NC		
G	ORIFICE DIAMETRES: F = 1mm (size 16mm only) G = 1.5mm (size 16mm only)	N = 2mm (size 16mm only) M = \emptyset 3 mm (solo taglia 20 mm)	P = \emptyset 3.5 mm (solo taglia 20 mm) T = \emptyset 4.4 mm (pressure compensated only)
W	SEAL MATERIAL: W = FKM		
2	BODY MATERIAL: 2 = BRASS		
0	OVERMOULDING MATERIAL OF COIL: 0 = cartridge		
P	COIL DIMENSIONS: P = \emptyset 16 7 = \emptyset 20		
3	VOLTAGE: 1 = 6 V DC 3.1 W (size 16 mm only) 2 = 12 V DC 4.3 W (size 20 mm only) 3 = 24 V DC 3.1 W (size 16 mm only) 4 = 24 V DC 4.3 W (size 20 mm only)	5 = 12 V DC 3.1 W (size 16 mm only) 6 = 6 V DC 4.3 W (size 20 mm only) 10 = 6 V DC 4.2 W (size 20 mm only, pressure compensated) 11 = 24 V DC 4.2 W (size 20 mm only, pressure compensated)	12 = 12 V DC 4.2 W (size 20 mm only, pressure compensated) 13 = 6 V DC 3 W (size 16 mm only, pressure compensated) 14 = 12 V DC 3 W (size 16 mm only, pressure compensated) 15 = 24 V DC 3 W (size 16 mm only, pressure compensated)

SERIES CP PROPORTIONAL SOLENOID VALVES

HYSTERESIS AND RESPONSE TIMES

DIAGRAM LEGEND:

Q = flow (l/min)
I = current (A)
FS = full scale

NOTE TO THE TABLE:
* in the pressure compensated version the counter pressure at the valve outlet must be always lower than 15-20% of the inlet pressure.

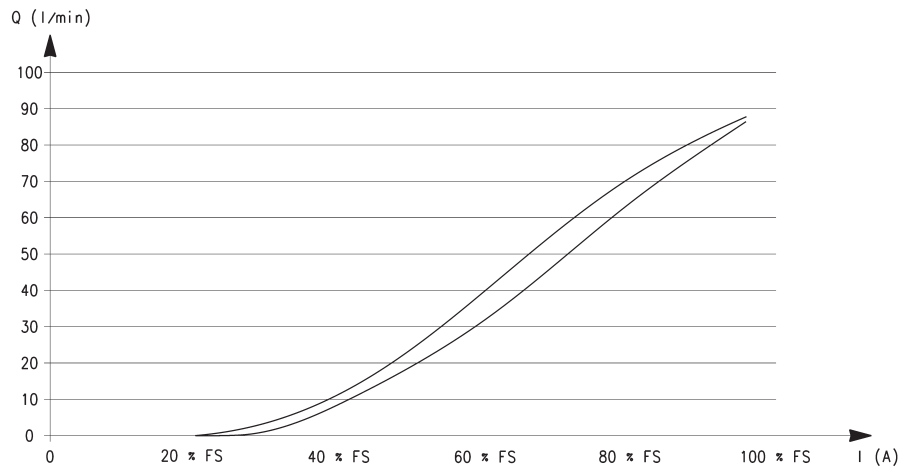

RESPONSE TIMES calculated according to the maximum flow at each operating pressure. [Electromechanical response time: 10 ms]							
Ø	Inlet pressure (bar)	Load response time (ms)			Exhaust response time (ms)		
		0% - 10%	0% - 90%	10% - 90%	100% - 90%	100% - 10%	90% - 10%
1 mm	8	12	42	30	9	33	24
1.5 mm	5	12	39	27	9	33	24
2 mm	3	11	39	28	9	33	26
3 mm	2.8	13	29	16	14	28.5	14.5
3.5 mm	2	15	31	16	12.5	27.5	15
4.4 mm *	2.8	13	52	49	10	37	27

FLOW DIAGRAMS - Size 16mm

SERIES CP PROPORTIONAL SOLENOID VALVES

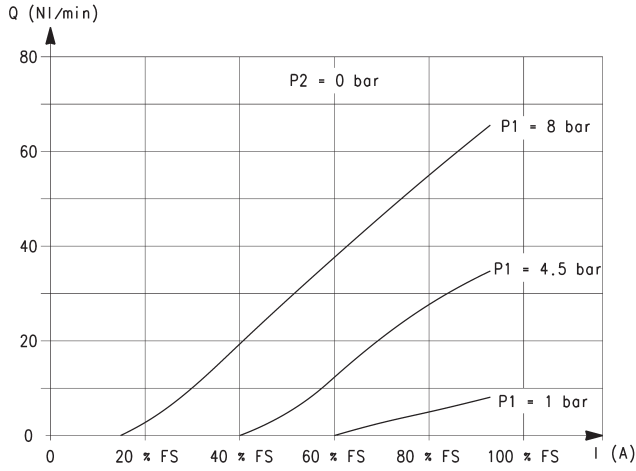

Nominal diameter 1mm

Q = flow (l/min)
I = current (A)
P1 = pressure in load (bar)
P2 = 0 [free flow pressure] (bar)
FS = full scale of the command signal

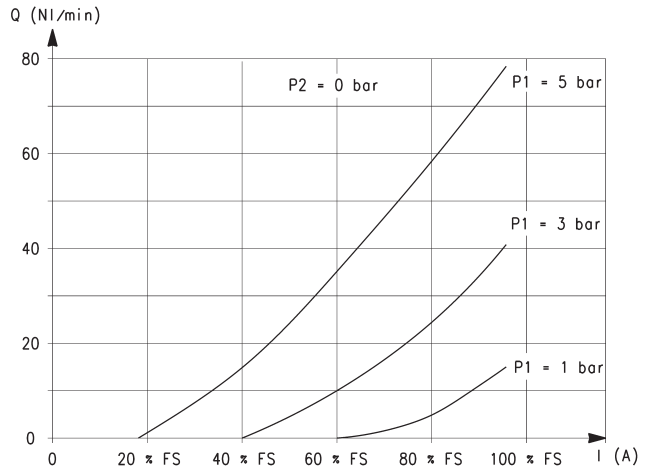

Nominal diameter 1.5mm

Q = flow (l/min)
I = current (A)
P1 = pressure in load (bar)
P2 = 0 [free flow pressure] (bar)
FS = full scale of the command signal

FLOW DIAGRAMS - Size 16 mm pressure compensated

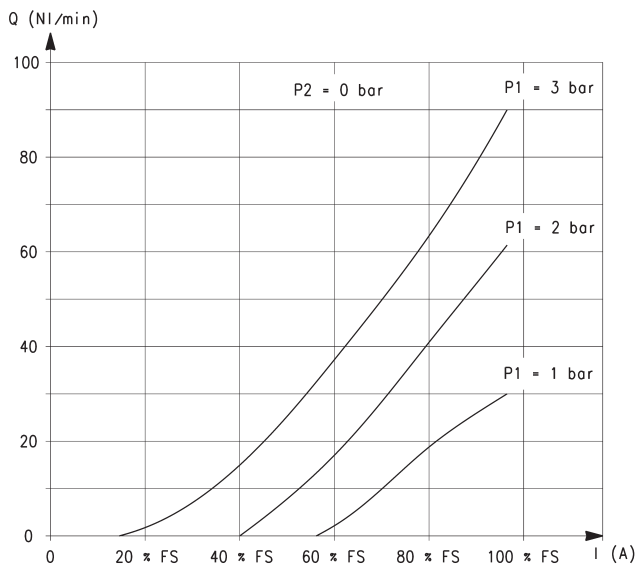

Nominal diameter 2mm

Q = flow (l/min)
I = current (A)
P1 = pressure in load (bar)
P2 = 0 [free flow pressure] (bar)
FS = full scale of the command signal

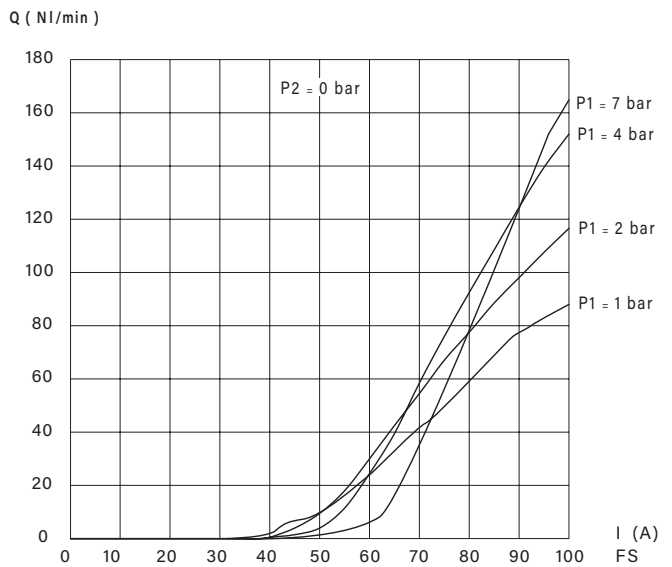

Nominal diameter 4.4mm

Q = flow (l/min)
I = current (A)
P1 = pressure in load (bar)
P2 = 0 [free flow pressure] (bar)
FS = full scale of the command signal

FLOW DIAGRAMS - Size 20mm

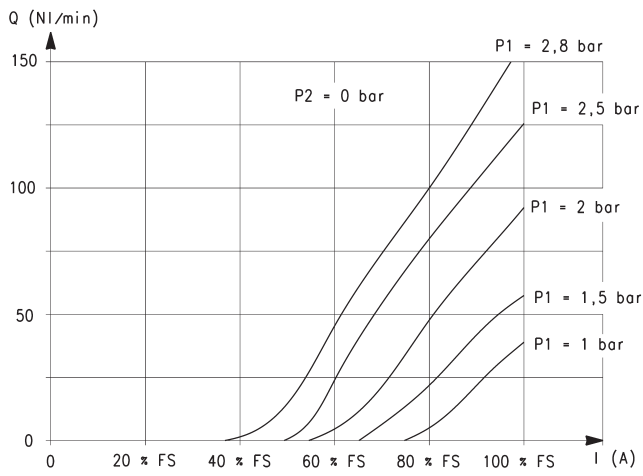

Nominal diameter 3mm

Q = flow (l/min)
 I = current (A)
 P1 = pressure in load (bar)
 P2 = 0 [free flow pressure] (bar)
 FS = full scale of the command signal

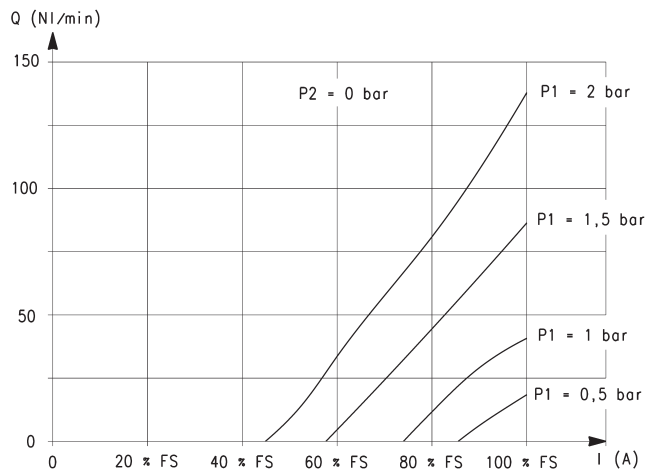

Nominal diameter 3.5mm

Q = flow (l/min)
 I = current (A)
 P1 = pressure in load (bar)
 P2 = 0 [free flow pressure] (bar)
 FS = full scale of the command signal

FLOW DIAGRAMS - Size 20mm pressure compensated

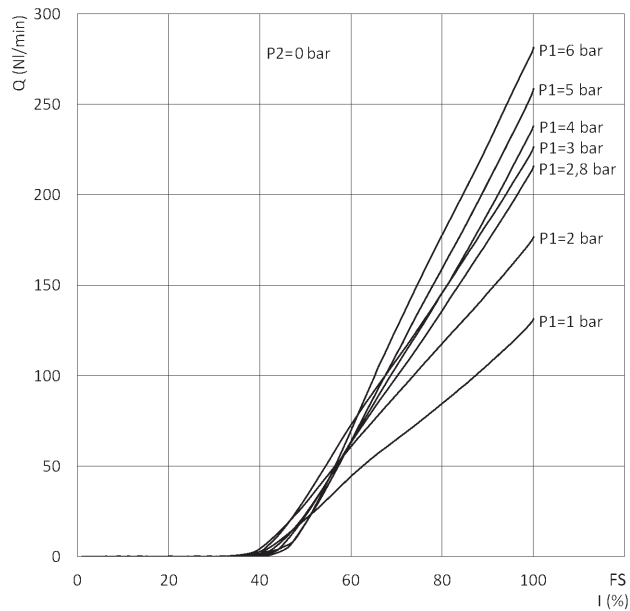

Nominal diameter 4.4mm

Q = flow (l/min)
 I = current (A)
 P1 = pressure in load (bar)
 P2 = 0 [free flow pressure] (bar)
 FS = full scale of the command signal

MAXIMUM FLOW ACCORDING TO THE INLET PRESSURE

SERIES CP PROPORTIONAL SOLENOID VALVES

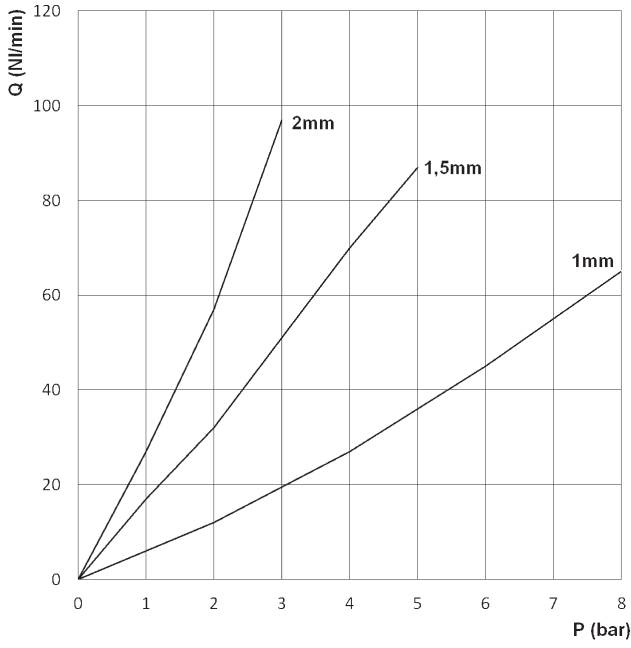

Size 16 mm

Q = Flow (NL/min)
P = Inlet pressure (bar)

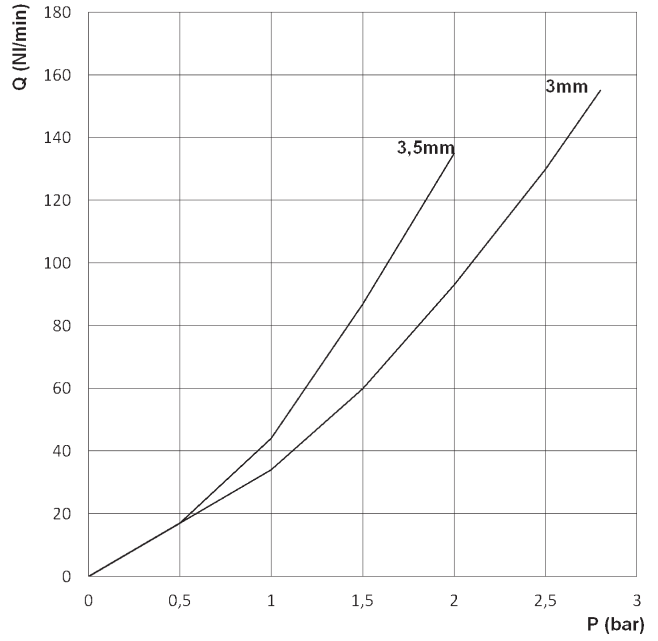

Size 20 mm

Q = Flow (NL/min)
P = Inlet pressure (bar)

Solenoid valves, size 16mm



Out of stock version

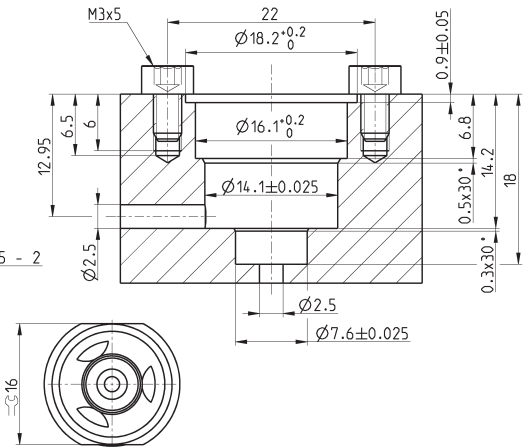
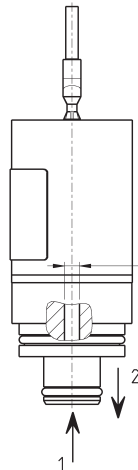
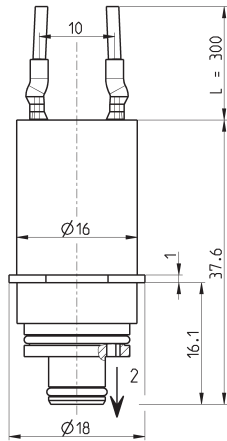
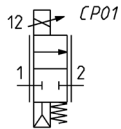

Mod.	Orifice Ø (mm)	Max operating pressure (bar)	Max flow (NL/min)	Max flow kv (l/min)	Operation voltage (V DC)	Max current (mA)
CP-C621-FW2-0P1	1	8	70	0.55	6	410
CP-C621-GW2-0P1	1.5	5	80	0.88	6	410
CP-C621-NW2-0P1	2	3	90	1.42	6	410
CP-C621-FW2-0P3	1	8	70	0.55	24	103
CP-C621-GW2-0P3	1.5	5	80	0.88	24	103
CP-C621-NW2-0P3	2	3	90	1.42	24	103
CP-C621-FW2-0P5	1	8	70	0.55	12	238
CP-C621-GW2-0P5	1.5	5	80	0.88	12	238
CP-C621-NW2-0P5	2	3	90	1.42	12	238

Solenoid valves, size 16m

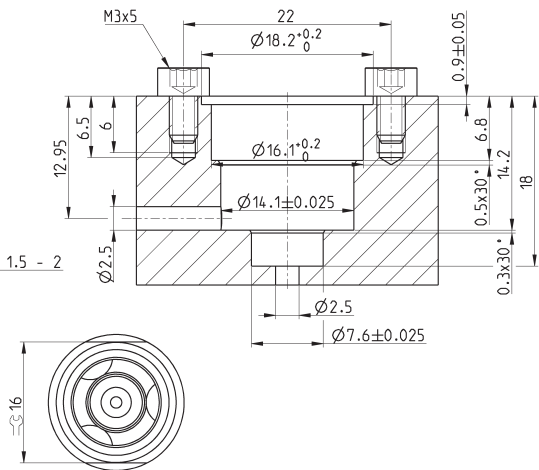
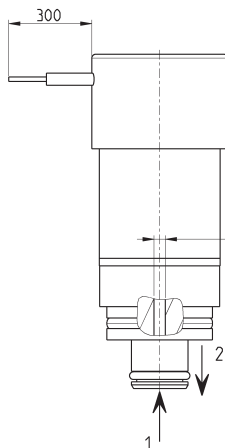
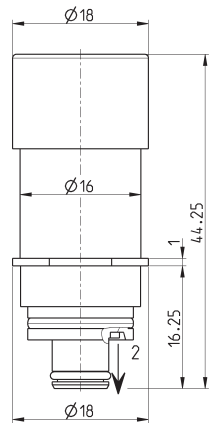
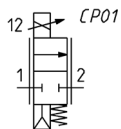

Mod.	Orifice Ø (mm)	Max operating pressure (bar)	Max flow (NL/min)	Max flow kv (l/min)	Operation voltage (V DC)	Max current (mA)
CPN-C621-FW2-0P1	1	8	70	0.55	6	410
CPN-C621-GW2-0P1	1.5	5	80	0.88	6	410
CPN-C621-NW2-0P1	2	3	90	1.42	6	410
CPN-C621-FW2-0P3	1	8	70	0.55	24	103
CPN-C621-GW2-0P3	1.5	5	80	0.88	24	103
CPN-C621-NW2-0P3	2	3	90	1.42	24	103
CPN-C621-FW2-0P5	1	8	70	0.55	12	238
CPN-C621-GW2-0P5	1.5	5	80	0.88	12	238
CPN-C621-NW2-0P5	2	3	90	1.42	12	238

Solenoid valves, size 16m pressure compensated

New

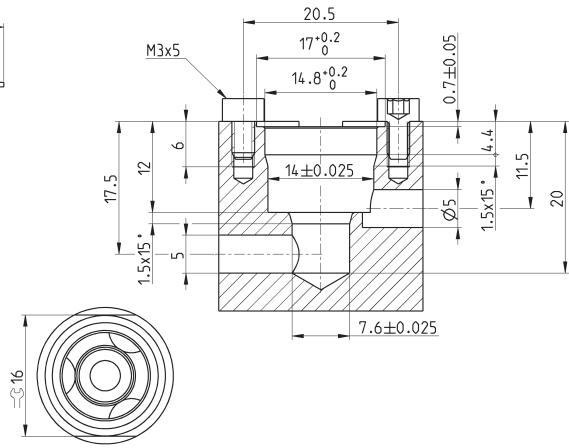
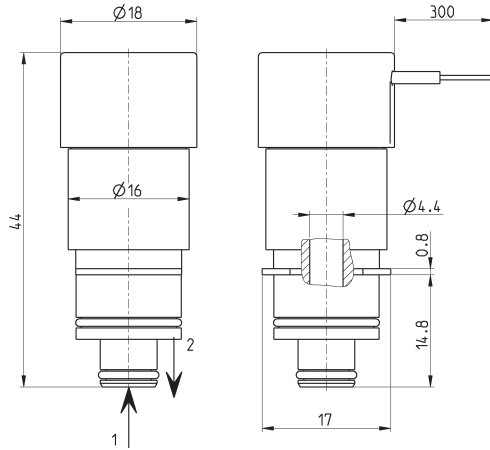
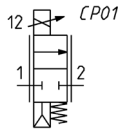

Mod.	Orifice Ø (mm)	Max operating pressure (bar)	Max flow (Nl/min)	Max flow kv (l/min)	Operation voltage (V DC)	Max current (mA)
CP-C821-TW2-0P13	4.4	7	160	-	6	410
CP-C821-TW2-0P14	4.4	7	160	-	12	205
CP-C821-TW2-0P15	4.4	7	160	-	24	103

SERIES CP PROPORTIONAL SOLENOID VALVES

Solenoid valves, size 20mm

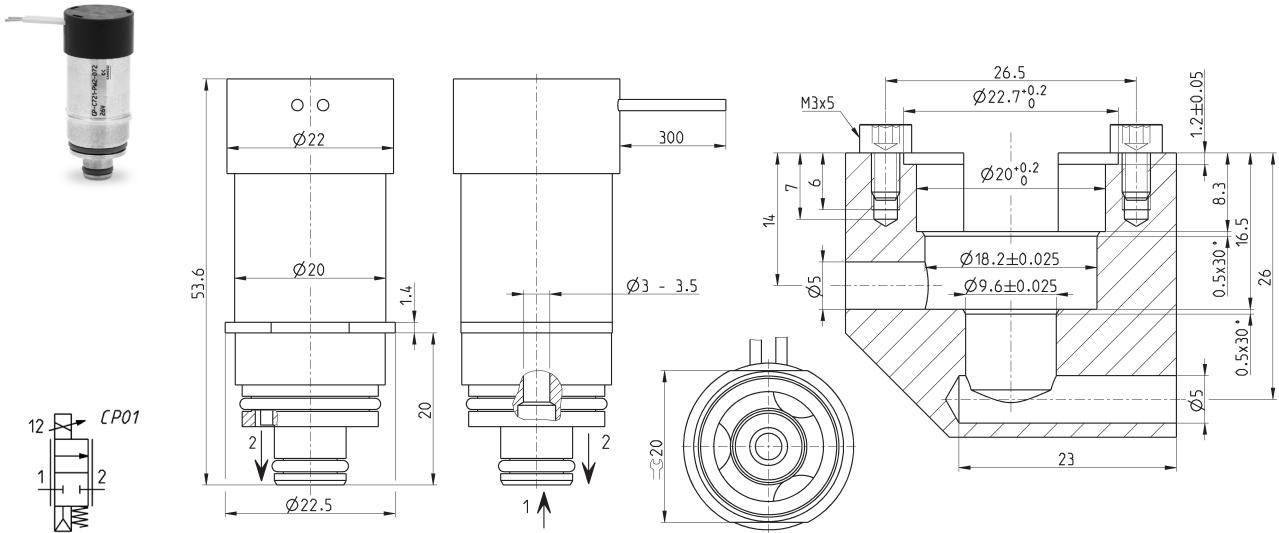

Mod.	Orifice Ø (mm)	Max operating pressure (bar)	Max flow (NL/min)	Max flow kv (l/min)	Operation voltage (V DC)	Max current (mA)
CP-C721-MW2-072	3	2.8	150	2.8	12	313
CP-C721-MW2-074	3	2.8	150	2.8	24	154
CP-C721-MW2-076	3	2.8	150	2.8	6	615
CP-C721-PW2-072	3.5	2	130	3	12	313
CP-C721-PW2-074	3.5	2	130	3	24	154
CP-C721-PW2-076	3.5	2	130	3	6	615

Solenoid valves, size 20mm pressure compensated

New

Working nominal pressure: 2.8 bar

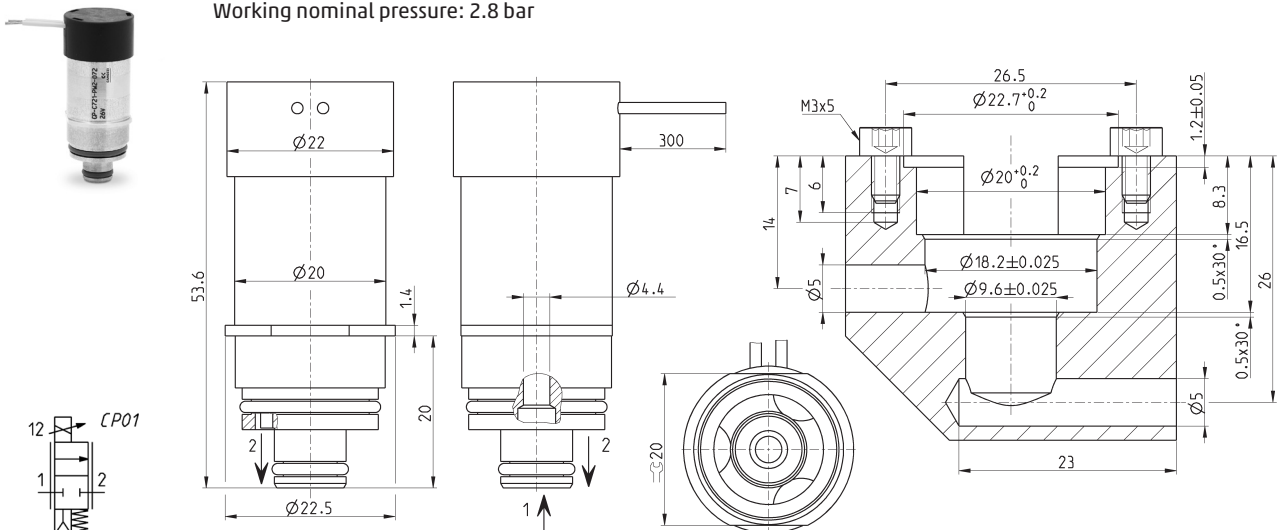

Mod.	Orifice Ø (mm)	Max operating pressure (bar)	Max flow (NL/min)	Max flow kv (l/min)	Operation voltage (V DC)	Max current (mA)
CP-C921-TW2-0710	4.4	6	200	4	6	700
CP-C921-TW2-0711	4.4	6	200	4	24	175
CP-C921-TW2-0712	4.4	6	200	4	12	350

New

Sub-base

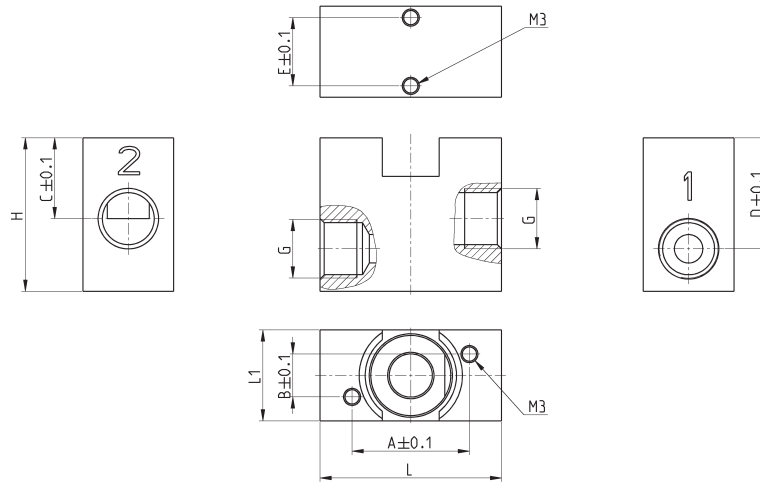

CP-S6 = for 16 mm versions
CP-C6... and CPN-C6...
CP-S8 = only for 16 mm
versions CP-C8...
CP-S7 = for 20 mm versions
CP-C7... and CPN-C9...

SERIES CP PROPORTIONAL SOLENOID VALVES

Mod.	Ø	A	B	C	D	E	G	H	L	L1
CP-S6	16	20.7	7.5	14.2	19.5	12	G1/8	27	32	16
CP-S7	20	25.2	8	14	22.5	15	G1/4	31.5	45	22
CP-S8	16	17.75	10.25	13.2	17.5	12	G1/8	27	32	16

Series 130 electronic control device for proportional valves

PWM control device, with current control system for directly operated proportional valves



Series 130 electronic control device allows to pilot any proportional valve with a maximum current of 1 A.

It turns a standard inlet signal (0-10V or 4-20 mA) into a PWM signal to obtain at the solenoid outlet a current which is proportional to the inlet signal.

- » Closed loop current control (max current that can be provided = 1A)
- » Management of up and down ramp
- » Command signal 0-10V and 4-20mA
- » Regulation of min and max current (Span and Offset)

A control system of the provided current allows to compensate variations due to heating of the solenoid or to the variation of the supply voltage. It is possible to adjust the maximum and minimum current provided to the solenoid. The outlet signal can have a ramp progress that is adjustable between 0 and 5 s. The device has a firmware dedicated to the proportional valve to pilot in order to guarantee the best performance.

GENERAL DATA

Material of container	Polycarbonate
Electrical connections	screw
Environmental temperature	0 ÷ 50°C
Mounting	in any position
Power supply	6 V ÷ 24 V DC (± 10%)
Consumption	0.4 W (without valve)
Analogical input	0 ÷ 10 V 4 ÷ 20 mA
Input impedance	>30 Kohm with inlet under voltage <200 ohm with inlet under current
Output PWM	120 Hz ÷ 11.7 KHz (fixed, according to the valve chosen)
Maximum current (valve)	1 A
Protection	Polarity inversion, short circuit of the outlet
External diameter of cable jacket	5 ÷ 7.5 mm with seal only 4 ÷ 6 mm with reducer and seal
Conductor section	26 ÷ 16 AWG / 0,13 ÷ 1,5 mm ²
Maximum length supply/signal cable	10 m
Maximum length valve cable	5 m
IP protection class according to EN 60529	IP 54
Ramp function	Adjustable time from 0 to 5 s
Regulation min. current (Offset)	0% ÷ 40% F.S.
Regulation maximum current	50% ÷ 100% F.S.

CODING EXAMPLE

130	-	2	2	2
------------	----------	----------	----------	----------

130	SERIES
2	VOLTAGE: 2 = 24 V DC (max power 24 W) 3 = 12 V DC (max power 12 W) 4 = 6 V DC (max power 6 W) 5 = 11 V DC (max power 11 W)
2	POWER: 1 = 3 W 2 = 6.5 W 3 = 3.2 W 4 = 4.3 W 5 = 10 W 6 = 4.2 W 7 = 2.5 W
2	PWM FREQUENCY: 2 = 500 Hz 3 = 1 KHz

SERIES 130 ELECTRONIC CONTROL DEVICE

NOTE: it is possible to realize configurations with voltage, power and PWM frequency values that are not yet foreseen in the coding example. For further information we suggest you to contact our technical department.

ELECTRICAL CONNECTIONS AND SETTINGS

DRAWING LEGEND:

- 1 = 6 ÷ 24 V DC (supply)
- 2 = 0 V (Ground) common also for the reference signal
- 3 = analogical reference signal 0 ÷ 10V DC
- 4 = analogical reference signal 4 ÷ 20 mA
- A = regulation of min. current (OFFSET)
- B = regulation of max. current (SPAN)
- C = regulation of the PWM outlet up and down ramp
- D = red LED
- E = yellow LED

Note 1: the GND of the reference signal and the GND of supply have to be linked together.

Note 2: For the valve connection use a connector without protection - diodes, varistors, etc... - as these might alter the regulation of the device.

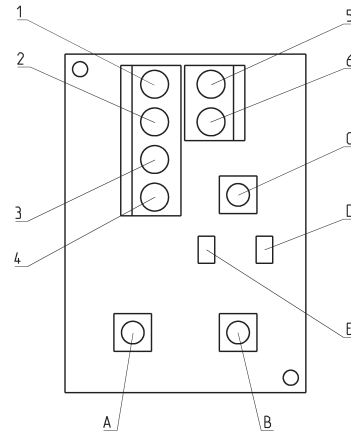

Series 130 electronic control device



NOTE: it is possible to realize configurations with voltage, power and PWM frequency values that are not shown in the table below. For further information we suggest you to contact our technical department.

Mod.	Matching valve family	Valve voltage (Output)	Adjusted power	Adjusted frequency
130-222	Series AP - size 22 mm	24 VDC	6.5 W	500 Hz
130-322	Series AP - size 22 mm	12 VDC	6.5 W	500 Hz
130-252	Series AP - size 22 mm	24 VDC	10 W	500 Hz
130-352	Series AP - size 22 mm	12 VDC	10 W	500 Hz
130-213	Series AP - size 16 mm	24 VDC	3 W	1000 Hz
130-313	Series AP - size 16 mm	12 VDC	3 W	1000 Hz
130-433	Series CP - size 16 mm	6 V DC	3.2 W	1000 Hz
130-533	Series CP - size 16 mm	11 V DC	3.2 W	1000 Hz
130-233	Series CP - size 16 mm	24 VDC	3.2 W	1000 Hz
130-442	Series CP - size 20 mm	6 V DC	4.3 W	500 Hz
130-342	Series CP - size 20 mm	12 VDC	4.3 W	500 Hz
130-242	Series CP - size 20 mm	24 VDC	4.3 W	500 Hz
130-463	Series CP pressure compensated - size 20 mm	6 V	4.2 W	1000 Hz
130-363	Series CP pressure compensated - size 20 mm	12 V	4.2 W	1000 Hz
130-263	Series CP pressure compensated - size 20 mm	24 V	4.2 W	1000 Hz
130-473	Series CP pressure compensated - size 16 mm	6 V	2.5 W	1000 Hz
130-373	Series CP pressure compensated - size 16 mm	12 V	2.5 W	1000 Hz
130-273	Series CP pressure compensated - size 16 mm	24 V	2.5 W	1000 Hz

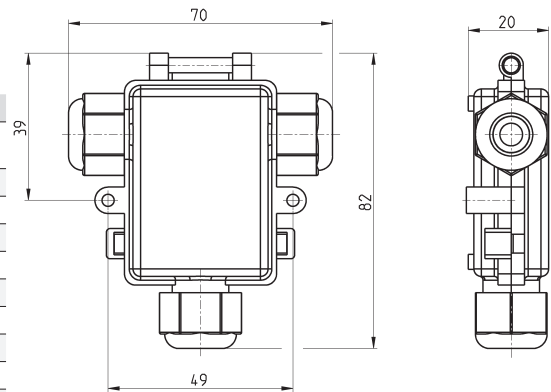

Connector Mod. 125-800 DIN 43650 pin spacing 9,4mm

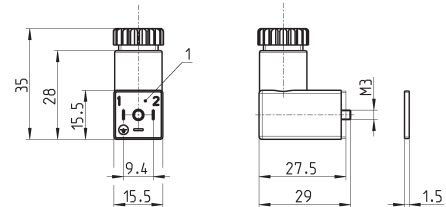

Mod.
125-800

1 = 90° adjustable connector

Connector Mod. 122-800 DIN 43650 (PG)

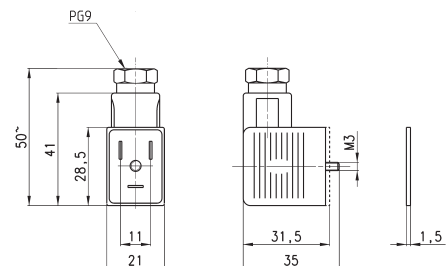

Mod.	Torque (Nm)
122-800	0.5

Series LR digital proportional servo valves

3/3-way directly operated servo valves for the flow (LRWD2), pressure (LRPD2) and position (LRXD2) control



- » Digital version which is completely configurable through micro USB
- » Rotating spool system with a metal to metal seal
- » High flow rate
- » Electronic control to ensure high precision in the flow control
- » 3-way-function with 4 - 6 mm nominal diameters
- » Compact version for cabinet mounting on DIN-rail
- » Position control version

Series LR digital proportional servo valves are direct driven 3/3-way valves with a patented rotating spool system with closed loop control circuit. The electronic board is integrated into the valve's body ready to connect.

Series LR*D2 digital proportional servo valve has been designed to be as compact as possible in order to save space and to be mounted on a DIN-rail. Thanks to this new digital version, the valve can be configured through a USB connection according to different requirements.

GENERAL DATA

Power supply	24 V DC +/- 10%, max absorption 1.5 A
Command signal	+/- 10 V 0-10 V 4-20 mA
Hysteresis	1% FS LRWD2 - 0,2% FS LRPD2
Linearity	1% FS LRWD2 - 0.3% FS LRPD2
Switching time	see the following pages
Working temperature	from 0 to 50° C
Relative humidity of air	max. 90%
Direction of assembly	any
Maximum flow	see the diagrams on the following pages
Medium	filtered compressed air, unlubricated, according to ISO 8573-1 class 3.4.3, inert gas
Supply pressure	-0.9 to 10 bar
Leakage	< 1% of maximum flow rate
Electrical connection	male connector M12 8 poles
Hardware configuration port	micro USB

CODING EXAMPLE

L	R	W	D	2	-	3	4	-	1	-	A	-	00
----------	----------	----------	----------	----------	----------	----------	----------	----------	----------	----------	----------	----------	-----------

L	SERIES: L = proportional servo valves	
R	TECHNOLOGY: R = rotating spool	
W	VERSION: W = flow control P = pressure control X = position control	
D	ELECTRONICS: D = digital	
2	MODEL: 2 = compact DIN-RAIL	
3	FUNCTION: 3 = 3/3-way	
4	NOMINAL DIAMETER: 4 = 4 mm 6 = 6 mm	
1	COMMAND SIGNAL (Setpoint): 1 = +/- 10 V 2 = 0 - 10 V 5 = 4 - 20 mA	
A	INPUT SIGNAL: 2 = 0 - 10 V (LRPD2 and LRXD2 only) 4 = 0 - 5V (LRPD2 and LRXD2 only) 5 = 4 - 20mA (LRPD2 and LRXD2 only)	A = internal encoder (LRWD2 only) B = 1 bar (internal sensor - LRPD2 only) D = 10 bar (internal sensor - LRPD2 only) E = 250 mbar (internal sensor - LRPD2 only) F = +1/-1 bar (internal sensor - LRPD2 only)
00	CABLE: 00 = no cable	2F = straight cable of 2 m 2R = 90° cable of 2 m 5F = straight cable of 5 m 5R = 90° cable of 5 m

SERIES LR DIGITAL PROPORTIONAL SERVO VALVES

FLOW DIAGRAMS FOR VALVES LRWD2-34 AND LRWD2-36

LEGEND:

- A = free flow
- B = ΔP1
- Q = flow (Nl/min)
- S = set point (%)
- Pa = inlet pressure (bar)

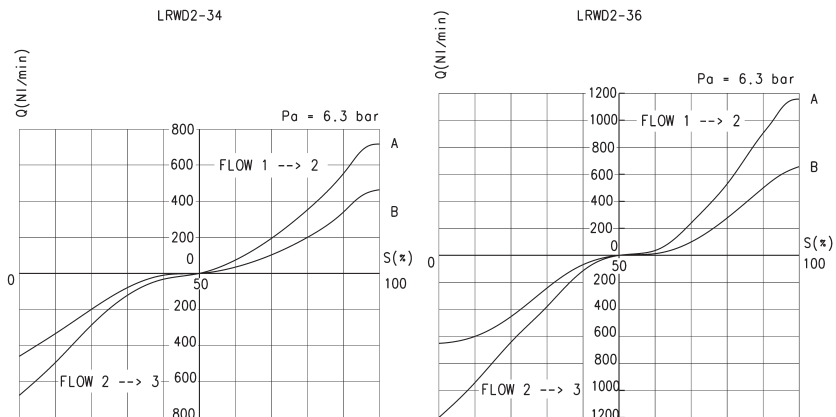

RESPONSE TIMES ACCORDING TO THE COMMAND SIGNAL IN COMPLIANCE WITH THE ISO 10094-2 STANDARD						
COMMAND SIGNAL	-5% ÷ +5%	+5% ÷ -5%	-25% ÷ +25%	+25% ÷ -25%	-90% ÷ +90%	+90% ÷ -90%
Time [ms] LRWD2-34	4	5	6	9	10	10
Time [ms] LRWD2-36	5	5	6	6	10	10

* closed valve with SET POINT = 0
 loaded valve with SET POINT = +
 exhaust valve with SET POINT = -

FLOW DIAGRAMS FOR VALVE LRPD2-34

LEGEND:
P = regulated pressure (bar)
F = flow (NL/min)
Pa = inlet pressure (bar)

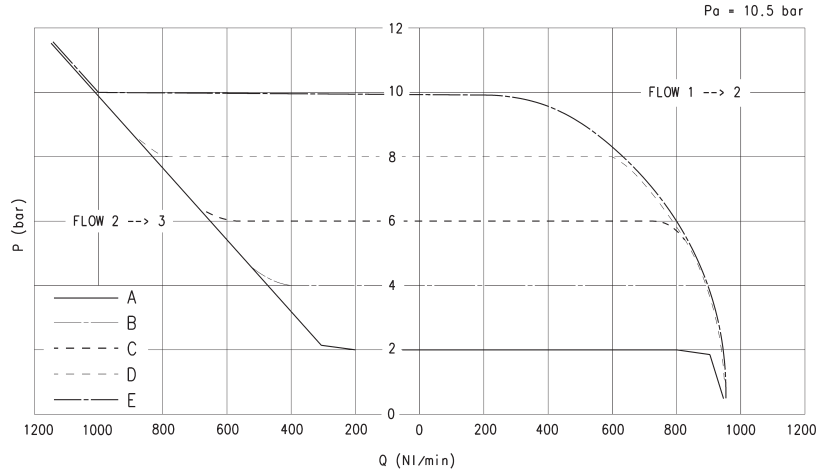

RESPONSE TIMES WITH COMMAND SIGNAL BETWEEN 0% AND 100% IN COMPLIANCE WITH ISO 10094-2 STANDARD

	Without volume	Volume 0,5 l	Volume 2 l
Filling [ms]	24	313	1841
Exhaust [ms]	35	663	3640

valve with SET POINT = 0% and regulated pressure = 0 bar

valve with SET POINT = 100% and regulated pressure = maximum pressure
(example: 10 - 1 bar or 250 mbar)

FLOW DIAGRAMS FOR VALVE LRPD2-36

LEGEND:
P = regulated pressure (bar)
F = flow (NL/min)
Pa = inlet pressure (bar)

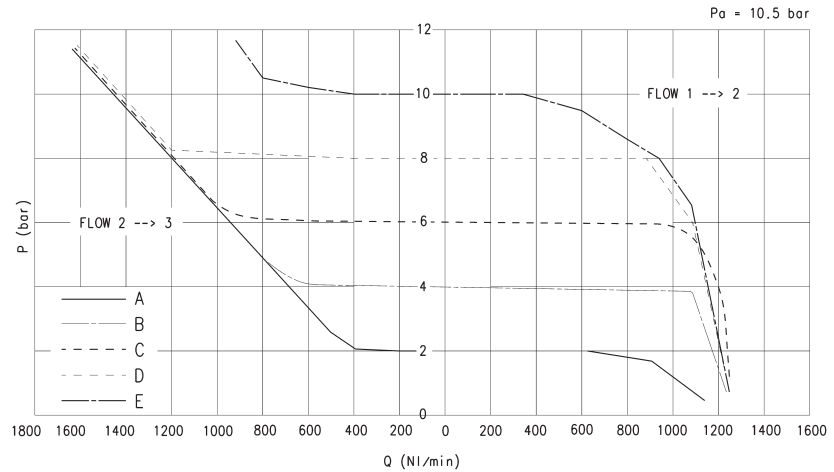

RESPONSE TIMES WITH COMMAND SIGNAL BETWEEN 0% AND 100% IN COMPLIANCE WITH ISO 10094-2 STANDARD

	Without volume	Volume 0,5 l	Volume 2 l
Filling [ms]	20	263	1560
Exhaust [ms]	32	357	1905

valve with SET POINT = 0% and regulated pressure = 0 bar

valve with SET POINT = 100% and regulated pressure = maximum pressure
(example: 10 - 1 bar or 250 mbar)

Series LRXD2 - pneumatic and electrical schemes for the installation

The LRXD2 servo valves are proportional valves with a high-precision integrated control for the positioning of pneumatic cylinders. The valves include a patented 3-way system based on the rotating spool principle with electronic control of the spool position. The servo pneumatic closed loop system allows the control of the position through the feedback of the external positioning sensor or of the Camozzi 6PF cylinder with the integrated linear transducer.

The electronic board which is integrated in the valve body manages speed and acceleration directly.

The Master valve Mod. LRXD2 is equipped with a proper signal to command a LRXD2 valve that will work as a slave-valve.

Configuration for the position control with two valves (Fig. 1)

A = Slave LRXD2-3*-2-A-00 - B = Master LRXD2-3*-4-00 - C = 6PF cylinder...

Configuration for the position control with a LRXD2 valve (Fig. 2)

A = Master LRXD2-3*-4-00 - B = PR104... - C = 6PF cylinder...

Fig.1

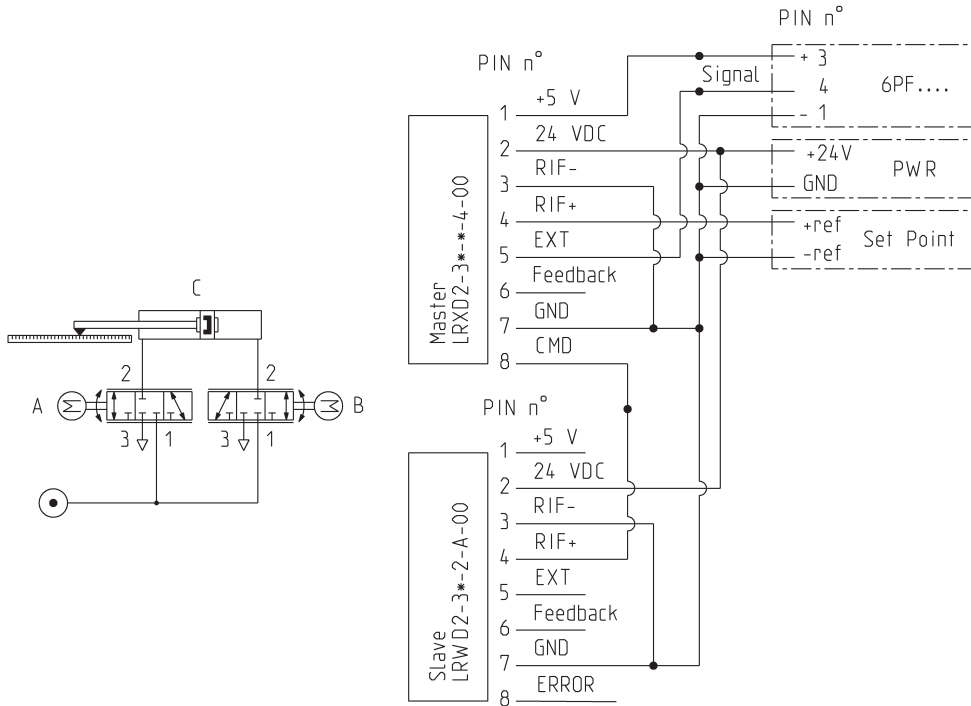
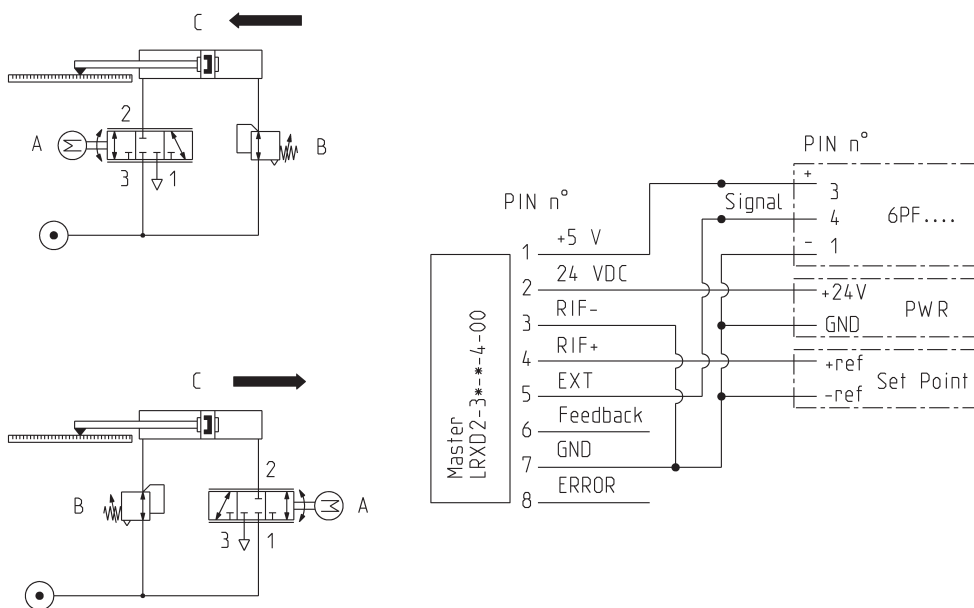
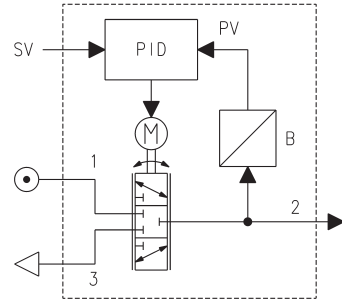
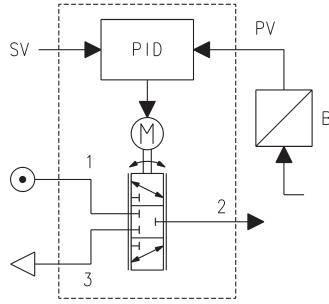

Fig.2



Series LRPD2 - pneumatic scheme for the installation

SV = setpoint value
 PV = process value
 B = sensor
 PID = proportional control, integrative, derivative



Series LR digital proportional servo valves - dimensions

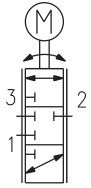

The detailed user and maintenance manual and the Hardware configuration Software of the valve is available online at <http://catalogue.camozzi.com>.

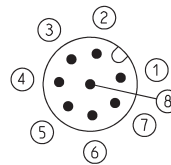
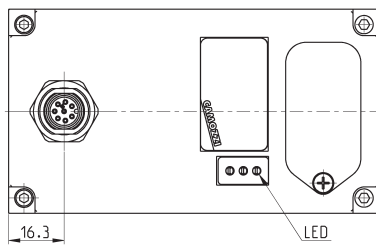
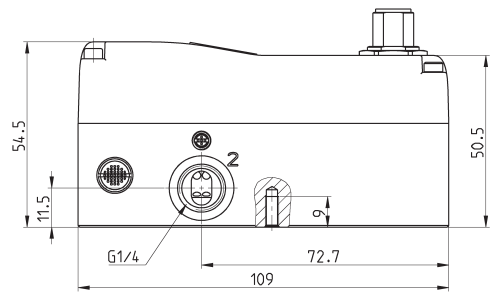
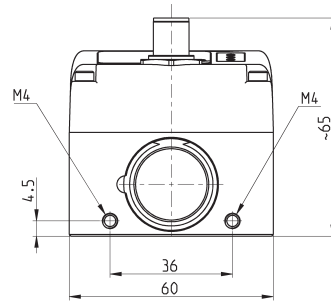
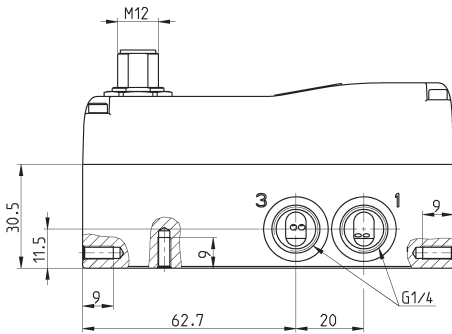
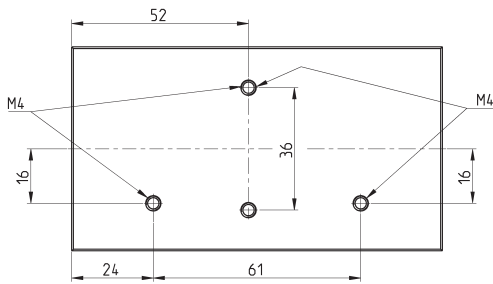

PIN	SIGNAL	DESCRIPTION
1	+5V	+5V power supply for external potentiometer transducer (ref. GND). If used, it is necessary to connect RIF- with GND.
2	24 V DC	24V DC power supply (logic and motor): connect to the positive pole of the 24V DC power supply (ref. GND)
3	RIF-	GND reference or NEGATIVE pole of the command signal (0-10V / 4-20mA / ±10V)
4	RIF+	POSITIVE reference of the command signal (0-10V / 4-20mA / ±10V)
5	EXT	for LRWD valve: not used for LRXD valve: feedback signal of the external transducer 0-5V / 0-10V / 4-20mA (ref. RIF-) for LRPD valve: feedback signal of the external transducer 0-5V / 0-10V / 4-20mA (ref. RIF-). To be used only with LRPD2 valve versions with external sensor.
6	FBK	feedback signal 0-10V / 4-20mA (ref. GND)
7	GND	common (reference pin 1 and 2): connect to the negative pole of the 24V DC power supply (compulsory)
8	ERR	for LRWD and LRPD valve: error signal (output) 0-24V (ref. GND) for LRXD valve: command signal 0-10V for slave valve (ref. GND)

Series LR digital proportional servo valves - technical characteristics



* To order the complete code, please replace the asterisk with 4 or 6 according to the desired nominal diameter.

SERIES LR DIGITAL PROPORTIONAL SERVO VALVES

Mod.	Control	Command/Input signal	Sensor/External signal	
LRWD2-3*-1-A-00	flow	+/- 10 V	-	
LRWD2-3*-2-A-00	flow	0-10 V	-	
LRWD2-3*-5-A-00	flow	4..20 mA	-	
LRPD2-3*-1-2-00	pressure	+/- 10 V	0..10 V	
LRPD2-3*-2-2-00	pressure	0-10 V	0..10 V	
LRPD2-3*-5-2-00	pressure	4..20 mA	0..10 V	
LRPD2-3*-1-4-00	pressure	+/- 10 V	0 - 5 V	
LRPD2-3*-2-4-00	pressure	0-10 V	0 - 5 V	
LRPD2-3*-5-4-00	pressure	4..20 mA	0 - 5 V	
LRPD2-3*-1-5-00	pressure	+/- 10 V	4..20 mA	
LRPD2-3*-2-5-00	pressure	0-10 V	4..20 mA	
LRPD2-3*-5-5-00	pressure	4..20 mA	4..20 mA	
LRPD2-3*-1-B-00	pressure	+/- 10 V	1 bar internal	
LRPD2-3*-2-B-00	pressure	0-10 V	1 bar internal	
LRPD2-3*-5-B-00	pressure	4..20 mA	1 bar internal	
LRPD2-3*-1-D-00	pressure	+/- 10 V	10 bar internal	
LRPD2-3*-2-D-00	pressure	0-10 V	10 bar internal	
LRPD2-3*-5-D-00	pressure	4..20 mA	10 bar internal	
LRPD2-3*-1-E-00	pressure	+/- 10 V	250 mbar internal	
LRPD2-3*-2-E-00	pressure	0-10 V	250 mbar internal	
LRPD2-3*-5-E-00	pressure	4..20 mA	250 mbar internal	
LRPD2-3*-1-F-00	pressure	+/- 10 V	+1/-1 bar internal	
LRPD2-3*-2-F-00	pressure	0-10 V	+1/-1 bar internal	
LRPD2-3*-5-F-00	pressure	4..20 mA	+1/-1 bar internal	
LRXD2-3*-1-4-00	position	+/- 10 V	0-5 V	suitable to work with the 6PF cylinder (see the PNEUMATIC ACTUATION catalogue)
LRXD2-3*-2-4-00	position	0-10 V	0-5 V	suitable to work with the 6PF cylinder (see the PNEUMATIC ACTUATION catalogue)
LRXD2-3*-5-4-00	position	4..20 mA	0-5 V	suitable to work with the 6PF cylinder (see the PNEUMATIC ACTUATION catalogue)
LRXD2-3*-1-2-00	position	+/- 10 V	0-10 V	
LRXD2-3*-2-2-00	position	0-10 V	0-10 V	
LRXD2-3*-5-2-00	position	4..20 mA	0-10 V	
LRXD2-3*-1-5-00	position	+/- 10 V	4..20mA	
LRXD2-3*-2-5-00	position	0-10 V	4..20mA	
LRXD2-3*-5-5-00	position	4..20mA	4..20mA	

Fixing foot Mod. LRADB



Supplied with:
2x feet
4x screws

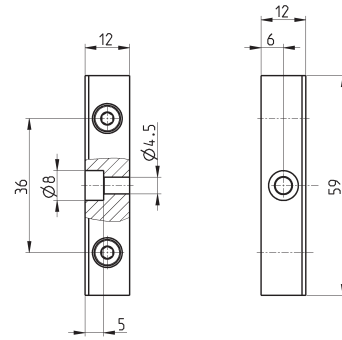

Mod.
LRADB

Mounting brackets for DIN-rail Mod. PCF-EN531



DIN EN 50022 (7,5mm x 35mm - width 1)

Supplied with:
2x mounting brackets
2x screws M4x6 UNI 5931
2x nuts

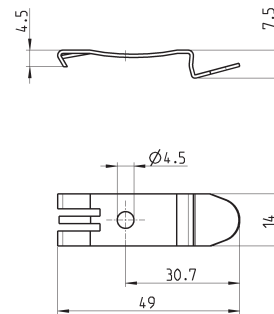

Mod.
PCF-EN531

Electrical tee box Mod. CS-AA08EC



Connection valve-PLC-external transducer

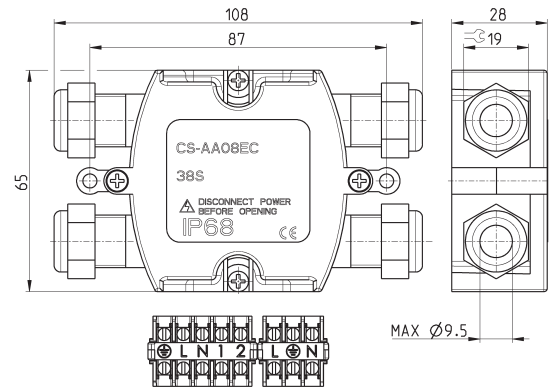

Mod.
CS-AA08EC

Straight female connector M12 8 poles



For electric supply and commands

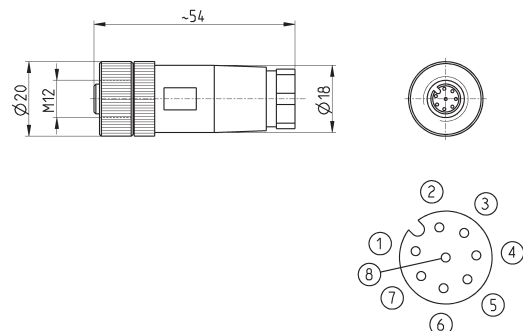

Mod.
CS-LF08HC

Cable with straight female connector M12 8 poles



For electrical supply and commands

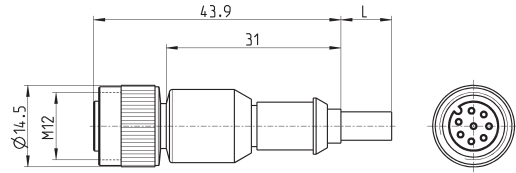

Mod.	Cable length (m)
CS-LF08HB-C200	2
CS-LF08HB-C500	5

Cable with angular (90°) female connector M12 8 poles



For electric supply and commands

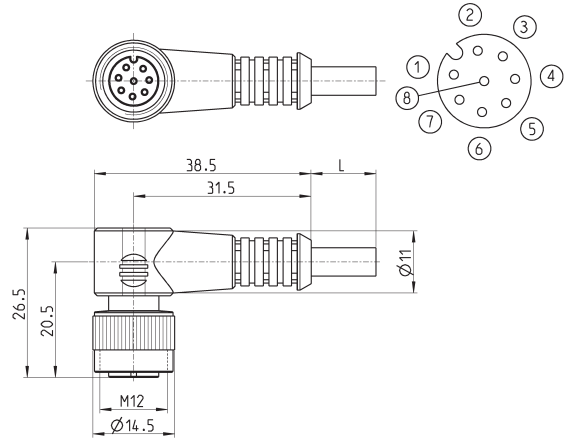

Mod.	Cable length (m)
CS-LR08HB-C200	2
CS-LR08HB-C500	5

USB to Micro USB cable Mod. G11W-G12W-2



For the hardware configuration of the Camozzi products

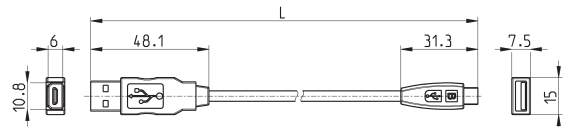

Mod.	description	connections	material for outer sheath	cable length "L" (m)
G11W-G12W-2	black shielded cable 28 AWG	standard USB to Micro USB	PVC	2

Open Frame Controller Modular proportional regulator



Modular system for proportional control of pressure, flow and position.



The Open Frame Controller can be easily configured to meet specific application needs, to provide the most efficient, turnkey solutions, this reducing assembly times and system complexity. The different Master and Slave modules can be combined and driven through simple serial communications, making the control of complex applications easier. Typical applications could include the mixing of different gases, piloting different pressures in different parts of the machine.

- » Closed loop flow control
- » Compatible to be used with oxygen
- » Composed of two base modules: Master and Slave
- » Customised, turnkey solutions
- » Analog, CanOpen or IO-Link interface

The new "Open Frame Controller" system is a platform for providing closed loop control of flow, pressure and position and is suitable for Industry 4.0 applications. The system is composed of two base modules: Master and Slave.

GENERAL DATA

Construction	modular, compact, directly operated
Number of ways	2/2-way 3/3-way Parallel
Flow	max. 90 Nl/min
Media	compressed air, inert gases and oxygen. Filtering according to ISO 8573-1 class 7.4.4
Supply pressure	-1 ÷ 10 bar
Operating pressure	-1 ÷ 10 bar
Ports	G1/8
Materials	seals: NBR, FKM, EPDM
Mounting position	any position
Analogical input	0-10 V or 4-20 mA
Analogical output	0-10 V
Supply voltage	24 VDC +/-10% o 12 VDC +/-5%
Current absorbed	0,3 A (Master module) 0,3 A (Slave module)
Control interface	CANopen CiA 301 RS485, RS232 IO-Link (connection type portclass B)
Protection class	IP20
Hysteresis	Pressure control version <= 3%FS; Flow control version <= 2%FS
Repeatability	Pressure control version <= 1%FS for pressures less than 1 Bar <=2%FS; Flow control version <= 2%FS
Resolution	Flow control version <= 2%FS
Environmental temperature (min and max °C)	0 ÷ 60°C For low temperature on request.
PWM frequency	1 kHz settable
Weight	300 g
Linearity	Pressure control version <= 2%FS; Flow control version <= 5%FS

CODING EXAMPLE

OF - 0 P 1 1 - L L W 2 - D - A - 04 - OX2 - CAC0001

OPEN FRAME

OF	SERIES: Open Frame	
0	ELECTRICAL INTERFACE: 0 = 0..10V analog / 24V supply 1 = CAN Open / 24 V supply 2 = IOlink -> CAN / 24V supply Portclass B compatible 8 = 4..20mA analog / 24V supply 9 = no header / 24V 4 = 0..10V analog / 12V supply 5 = CAN Open / 12 V supply 7 = 4..20mA analog / 12 V supply	A = no header/ 12V 3 = RS485 -> CAN / 24V supply T = TTL -> CAN / 24V E = Ethercat / 24V supply P = ProfiNet / 24V supply R = RS232 / 24V supply S = RS232 / 12V supply
P	CONTROL FUNCTION: = header only A = Open Loop (flow 2-way) Master B = Open loop (flow 3-way) Master & Slave Q = Flow 2- way closed loop Master C = Flow 3 way closed loop Master & Slave H = high flow 2-way pressure control (parallel) Master & Slave	N = pressure 2-way closed loop P = pressure 3-way closed loop Master & Slave W = position Controller single ended function Master & Slave X = position Controller A-side double ended function Master & Slave Y = position Controller B-side double ended function Master & Slave S = Slave only
1	SIZE: = header only 1 = SIZE 37 mm	
1	PNEUMATIC PORT: = header only 1 = G1/8	
L	MASTER VALVE SIZE: = header only 0 = mandatory for slaves F = Ø 1 mm H = Ø 1,2 mm L = Ø 1,6 mm N = Ø 2 mm Q = Ø 2,4 mm	
L	SLAVE VALVE SIZE: = header only 0 = mandatory for masters F = Ø 1 mm H = Ø 1,2 mm L = Ø 1,6 mm N = Ø 2 mm Q = Ø 2,4 mm	
W	SEALS MATERIAL: = header only W = FKM R = NBR E = EPDM	
2	BODY MATERIAL: = header only 2 = brass / aluminum	
D	MAX. PRESSURE (RELATIVE SENSOR) ONLY FOR MASTERS: = header only 0 = no relative pressure sensor; mandatory for Slaves B = 0,2 bar C = 1 bar D = 2 bar E = 7bar F = 10 bar G = +/- 1 bar	
A	MAX. PRESSURE (DIFFERENTIAL SENSOR) ONLY FOR MASTER: = header only 0 = no dp sensor A = 50mbar B = 200mbar C = 1bar	
04	NOZZLE SIZE FOR MASTER ONLY: = header only 00 = no nozzle 04 = 0,4 mm 06 = 0,6 mm 07 = 0,7 mm 09 = 0,9 mm 12 = 1,2 mm 14 = 1,4 mm	16 = 1,6 mm 18 = 1,8 mm 20 = 2,0 mm 23 = 2,3 mm 28 = 2,8 mm
OX2	CERTIFICATION: OX2 = Certification for Oxygen ASTM G93-03 Level B.	
CAC0001	Application code: increasing number for each special customized version	

Flow diagrams Open Frame - Closed loop flow control valve version

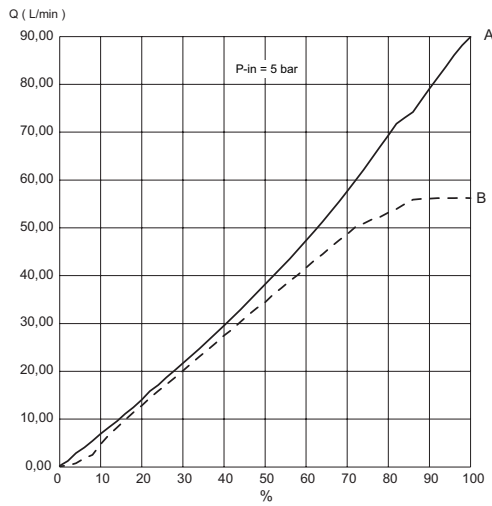

Q = Flow (l/min)
 % = Percentage of the command signal
 A = P out flow = P atmosphere
 B = Delta flow P 1 bar

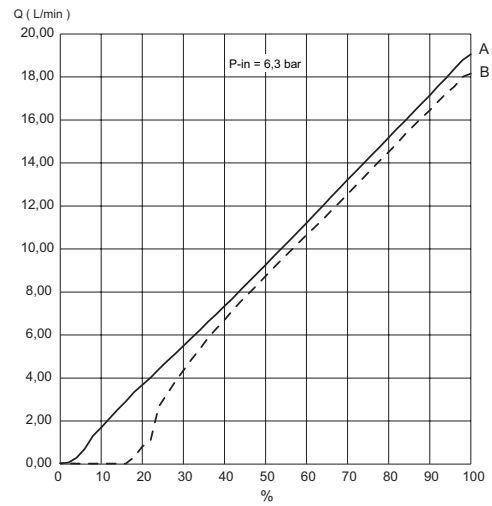

Q = Flow (l/min)
 % = Percentage of the command signal
 A = P out flow = P atmosphere
 B = Delta flow P 1 bar

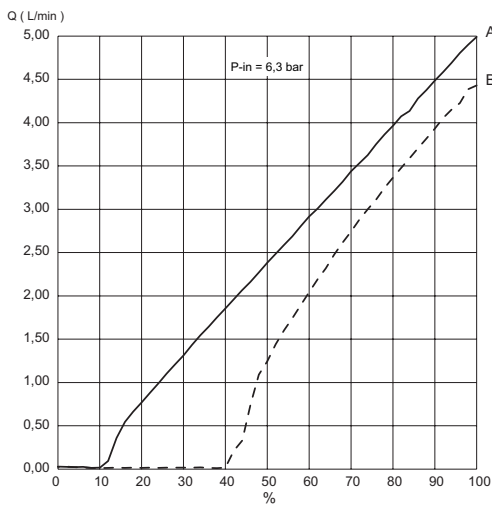

Q = Flow (l/min)
 % = Percentage of the command signal
 A = P out flow = P atmosphere
 B = Delta flow P 1 bar

Nota 1: The graphs shown above are for reference only. Thanks to the high flexibility of the Open Frame, the different modules will be calibrated accurately according to the specifications of each application, exploiting the product in the best way possible.

Flow diagrams Open Frame – 3-way and 2-way Pressure regulator version

OPEN FRAME

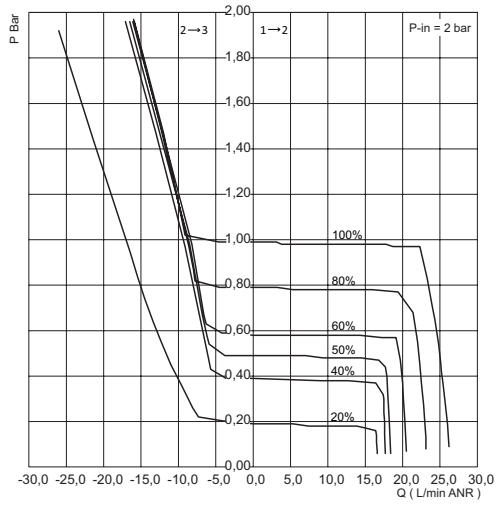

Operating pressure 1 bar

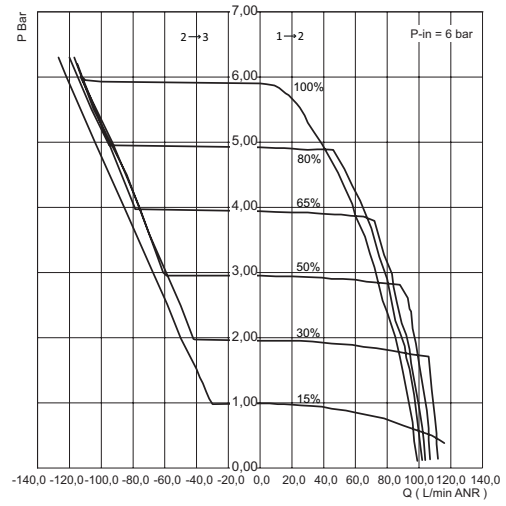

Operating pressure 6 bar

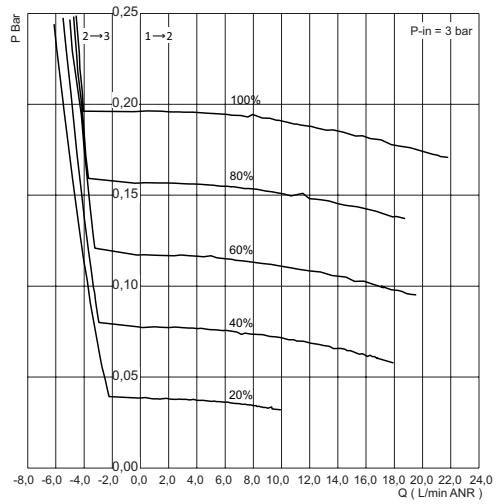

Operating pressure 0.2 bar

Nota 1: Regarding the pressure regulation graphs shown above, please do not consider the negative values when you refer to the 2-way regulator, as these values relate to the exhaust flow which is absent in the 2-way version.

Nota 2: The graphs shown above are for reference only. Thanks to the high flexibility of the Open Frame, the different modules will be calibrated accurately according to the specifications of each application, exploiting the product in the best way possible.

SERIES OPEN FRAME - PNEUMATIC SCHEME

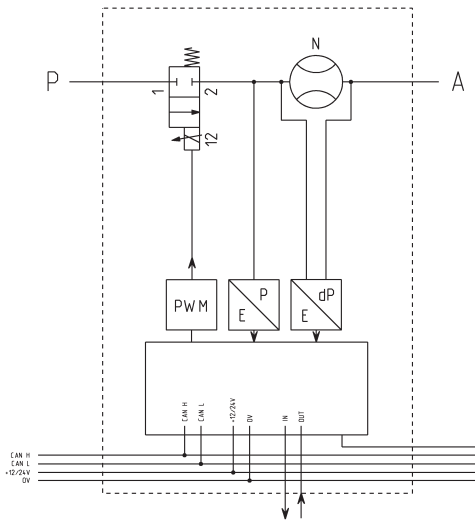

MASTER MODULE SCHEME

P= pressure inlet master
A= use of master
N= calibrated nozzle

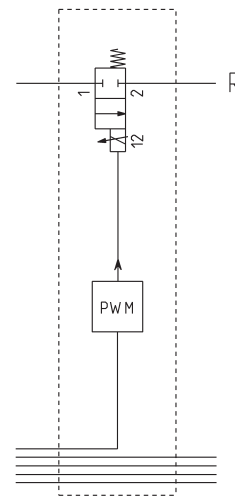

SLAVE MODULE SCHEME

R= slave exhaust

MOUNTING EXAMPLE

To correctly mount the modular MASTER and SLAVE components, insert the fixing elements (A) in the special seats between the two bodies and the O-Ring (C) in the seat on the SLAVE body.

Join the two bodies and fix them into position with the fixing nuts (B), close to the side in contact.

The positions of the covers (D), prepared at the factory, cannot be changed.

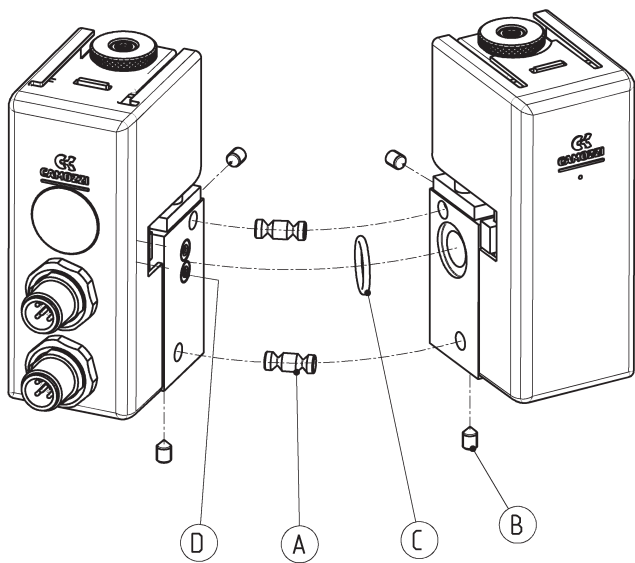

OPEN FRAME

Open Frame proportional controller - dimensions



OPEN FRAME

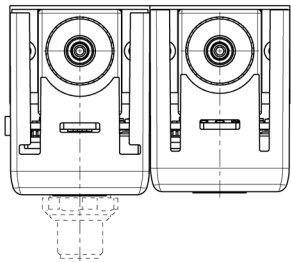
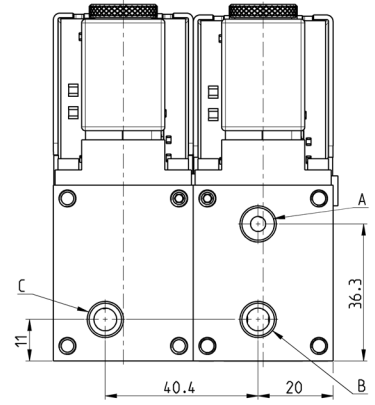
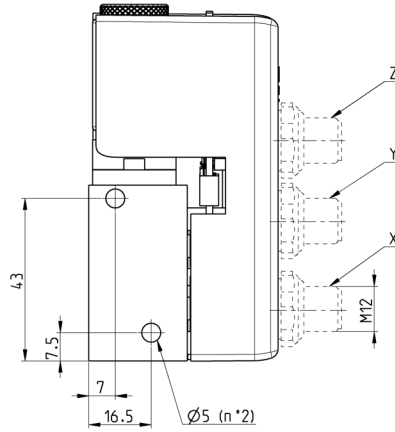
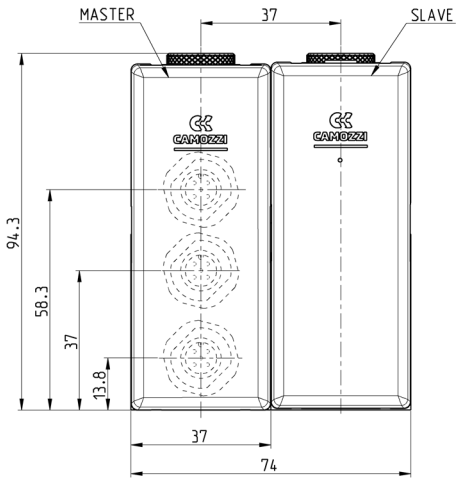
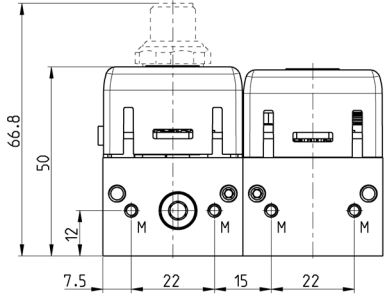

Mod.	X	Y	Z	A	B	C	M
OF-2	M12 5 PIN (Male)	M12 5 PIN (Male)	Micro USB	G1/8	G1/8	G1/8	M3 thread for mounting

Cable with M12 5 pin connector straight, female, not shielded

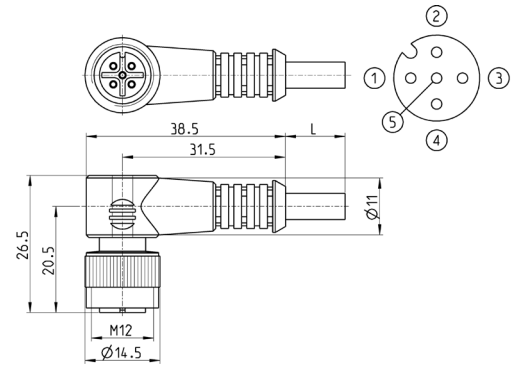

Mod.	Cable length (m)
CS-LR05HB-D200	2
CS-LR05HB-D500	5

USB to Micro USB cable Mod. G11W-G12W-2

For the hardware configuration of the Camozzi products

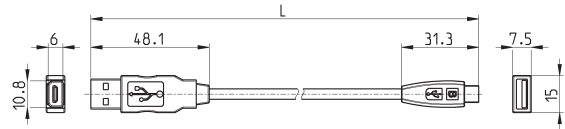

Mod.	description	connections	material for outer sheath	cable length "L" (m)
G11W-G12W-2	black shielded cable 28 AWG	standard USB to Micro USB	PVC	2

Series K8P electronic proportional micro regulator

Proportional regulator for the pressure control



- » High precision
- » Reduced response times
- » Minimum consumption
- » Self-regulation function
- » Flexibility of use
- » Compact design
- » Suitable for use with oxygen

The K8P regulator adjusts the outlet pressure through the operation of two K8 monostable valves according to the inlet signal and to the retroactivity of the internal pressure sensor. A self-adjusting function has been integrated into the regulator control algorithm to guarantee the highest levels of performance apart from the volume connected.

Series K8P electronic proportional micro regulators have evolved from our Series K8 mini-solenoid valves. Series K8P regulators guarantee excellent pressure regulation, fast response times, self-regulation and low energy consumption. Series K8P is a high performance proportional pressure regulator which is suitable for use in all applications where high precision, quick response times and low consumption are required.

GENERAL DATA

Fluids	filtered compressed air, unlubricated, according to ISO 8573-1 class 7.4.4, oxygen, inert gases (argon, molecular nitrogen)		
Pressures	Regulated pressure	Max inlet pressure	
	0.5 ÷ 10 bar	11 bar	
	0.15 ÷ 3 bar	4 bar	
	0.35 ÷ 7 bar	8 bar	
	0.05 ÷ 1 bar	1.5 bar	
Working temperature	0 ÷ 50°C		
Analogical input	0-10 V DC	4-20 mA	Ripple ≤ 0,2%
Analogical output	0.5 - 9.5 V [Feedback]		
Analog input impedance	20.000 Ω for versions 0-10 V 250 Ω for versions 4-20 mA		
Maximum flow	12 l/min with regulated pressure = 6 bar (IN Pres. 10 bar) 6 l/min with regulated pressure = 3 bar (IN Pres. 4 bar) 8 l/min with regulated pressure = 7 bar (IN Pres. 8 bar) 2 l/min with regulated pressure = 1 bar (IN Pres. 1.5 bar)		
Supply / Use	24 V - ~ 1 W		
Function	3/2 NC		
Linearity	≤ ±1% FS		
Hysteresis	±0.5% FS		
Resolution	±0.5% FS (referred to the command signal)		
Repeatability	±0.5% FS		
Minimal set point change	50 mV => 50 mB (10 bar) 100 mV => 30 mB (3 bar)		
Electrical connection	M8 4 Pin (Male)		
Protection class	IP65 (with standard sub-base or with single use) IP51 (with Light sub-base and Light Sub-base for the pressure remote reading)		

In compliance with the European Directive 2004/108/EC

CODING EXAMPLE

K8P	-	0	-	D	5	2	2	-	0
------------	----------	----------	----------	----------	----------	----------	----------	----------	----------

K8P	SERIES
0	<p>BODY DESIGN: 0 = Stand alone S = Standard Sub-base L = Light Sub-base T = Light Sub-base for the pressure remote reading</p>
D	<p>WORKING PRESSURE: D = 0 - 10 bar E = 0 - 3 bar F = 0 - 7 bar B = 0 - 1 bar</p>
5	<p>VALVE FUNCTIONS: 5 = 3/2-way NC</p>
2	<p>COMMAND: 2 = 0-10 V DC 3 = 4-20 mA</p>
2	<p>OUTPUT SIGNAL: 2 = 0-10 V</p>
0	<p>CABLE LENGTH: 0 = without cable 2F = straight cable, 2 m 2R = right angle cable (90 degrees), 2 m 5F = straight cable, 5 m 5R = right angle cable (90 degrees), 5 m</p>
OX1	<p>VERSIONS: = standard OX1 = for use with oxygen (in compliance with ASTM G93-03 Level E)</p>
<p>APPLICATIONS</p> <p>The K8P proportional regulator can be used as a pilot valve to control the opening of high flow valves or to check the high flow pressure regulators proportionally (version with sub-base for the pressure remote reading). It enables proportional control of power in lifting systems and can be used with inert gas to maintain a constant pressure in pneumatic cylinders or expansion valve chambers. It has also been designed to maintain a constant pressure during the pulling power applied to the wires in winding machines, to modulate pressure during the smoothing process in woodworking machines or to adjust the opening of diaphragm valves.</p>	

SERIES K8P ELECTRONIC PROPORTIONAL MICRO REGULATOR

Interface for single use without sub-base

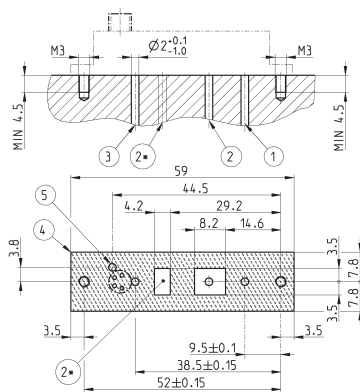

DRAWING LEGEND	
Notes	
1 = Inlet pressure	Pneumatic connection
2 = Outlet pressure	Pneumatic connection
2* = area for possible positioning of outlet port 2	Do not exceed the indicated outline
3 = Exhaust	Pneumatic connection
4 = OUTLET DIMENSION	
5 = VENT PORT FOR IP65	Optional when a OR seal is mounted

FLOW DIAGRAMS

SERIES K8P ELECTRONIC PROPORTIONAL MICRO REGULATOR

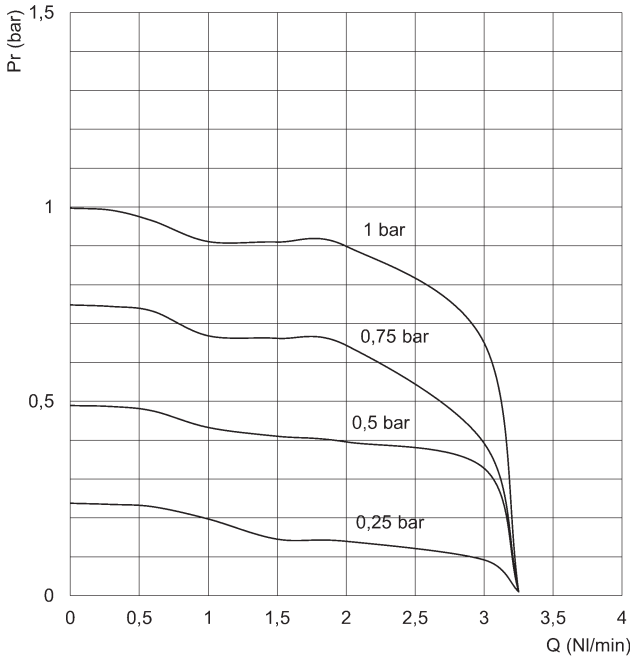

0-1 bar version

Pr = Outlet pressure (bar)*
Q = Flow (NL/min)*

* = Inlet pressure 2 bar

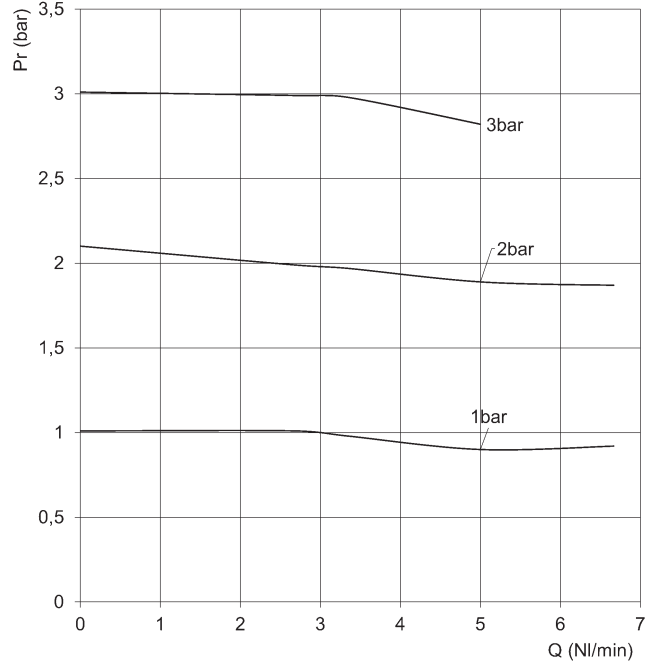

0-3 bar version

Pr = Outlet pressure (bar)*
Q = Flow (NL/min)*

* = Inlet pressure 4 bar

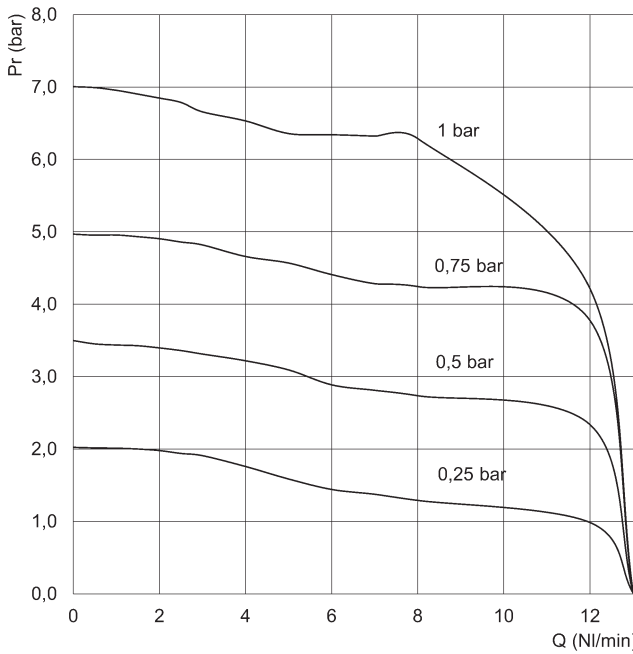

0-7 bar version

Pr = Outlet pressure (bar)*
Q = Flow (NL/min)*

* = Inlet pressure 8 bar

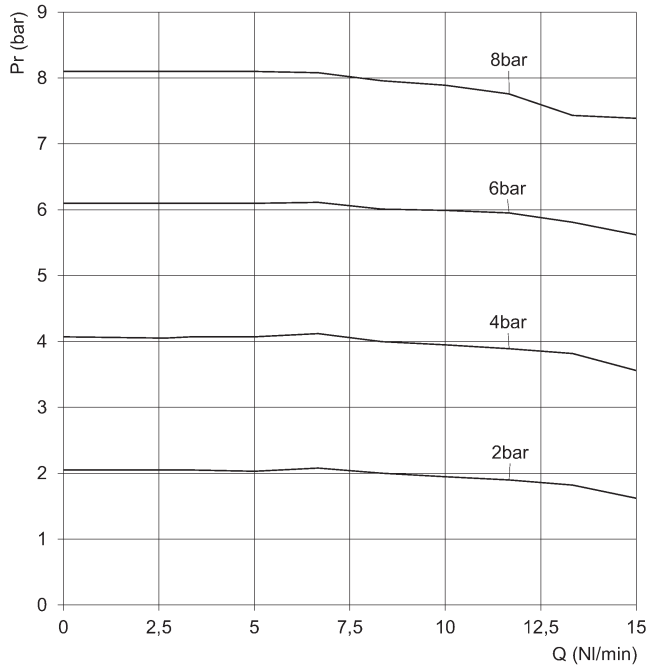

0-10 bar version

Pr = Outlet pressure (bar)*
Q = Flow (NL/min)*

* = Inlet pressure 10 bar

Series K8P electronic proportional micro regulator

* = sub-bases and single use can be supplied for all versions.
 ** = all the cables can be supplied for all versions.



M8 4-pole male connector

Pin 1: +24 V DC (Power supply)
 Pin 2: Command analogical signal 0-10 V DC or 4-20 mA
 Pin 3: 0 V (Ground) common also for the command signal
 Pin 4: Output analogical signal (according to the regulated pressure)

5 red LED
 6 green LED

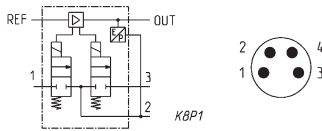
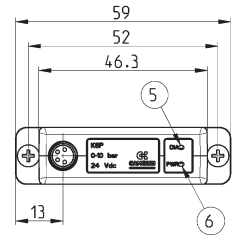
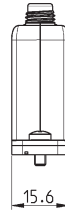
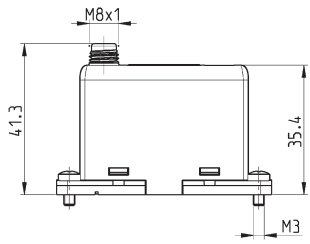

Mod.	Working pressure	Use with oxygen	Command
K8P- [*] -D522- ^{**}	0-10 bar	no	0-10 V DC
K8P- [*] -E522- ^{**}	0-3 bar	no	0-10 V DC
K8P- [*] -D532- ^{**}	0-10 bar	no	4-20 mA
K8P- [*] -E532- ^{**}	0-3 bar	no	4-20 mA
K8P- [*] -B522- ^{**}	0-1 bar	no	0-10 V DC
K8P- [*] -F522- ^{**}	0-7 bar	no	0-10 V DC
K8P- [*] -B532- ^{**}	0-1 bar	no	4-20 mA
K8P- [*] -F532- ^{**}	0-7 bar	no	4-20 mA
K8P- [*] -B522- ^{**} OX1	0-1 bar	yes	0-10 V DC
K8P- [*] -F522- ^{**} OX1	0-7 bar	yes	0-10 V DC
K8P- [*] -E522- ^{**} OX1	0-3 bar	yes	0-10 V DC
K8P- [*] -B532- ^{**} OX1	0-1 bar	yes	4-20 mA
K8P- [*] -F532- ^{**} OX1	0-7 bar	yes	4-20 mA
K8P- [*] -E532- ^{**} OX1	0-3 bar	yes	4-20 mA

Standard Sub-base

The use of a silencer (Mod. 2939 4) on the exhaust is recommended.

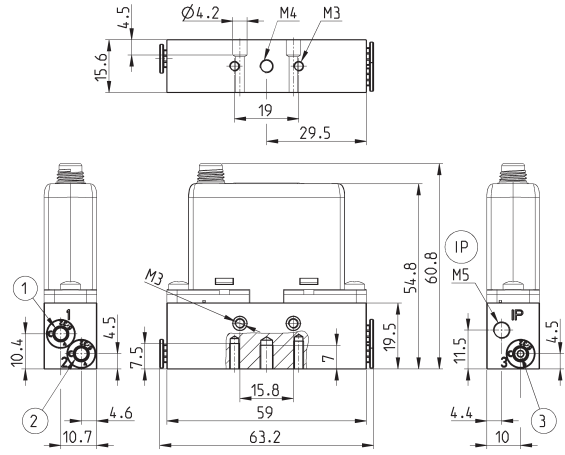

Mod.
K8P-AS

1 = Inlet pressure
2 = Outlet pressure
3 = Exhaust

IP = IP65 connection

Light Sub-base

The use of a silencer (Mod. 2931 M5, 2938 M5, 2901 M5) on the exhaust is recommended.

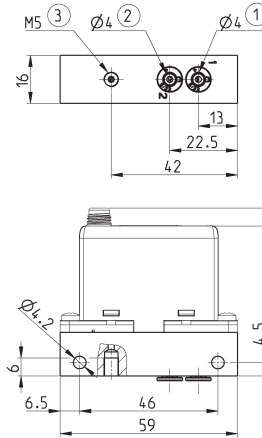

Mod.
K8P-AL

1 = Inlet pressure
2 = Outlet pressure
3 = Exhaust

Light Sub-base for the pressure remote reading

The use of a silencer (Mod. 2931 M5, 2938 M5, 2901 M5) on the exhaust is recommended.

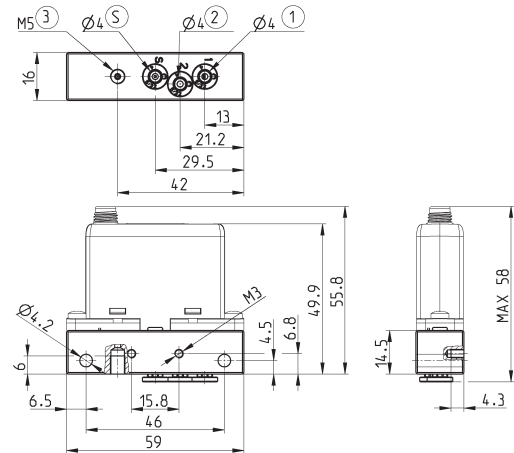

Mod.
K8P-AT

1 = Inlet pressure
2 = Outlet pressure
3 = Exhaust

S = remote-mounted sensor

Mounting bracket for DIN rail



DIN EN 50022 (7,5mm x 35mm - width 1)

Supplied with:
1x mounting bracket
1x screw M4x6 UNI 5931

This accessory cannot be used with the Light sub-base.

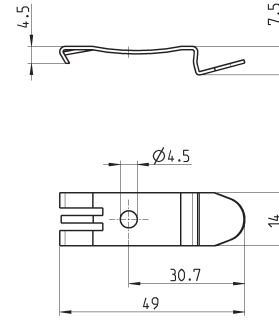

Mod.	
PCF-K8P	

Bracket for horizontal mounting, for standard sub-base



Supplied with:
1x mounting bracket
2x screws M3x8 UNI 5931

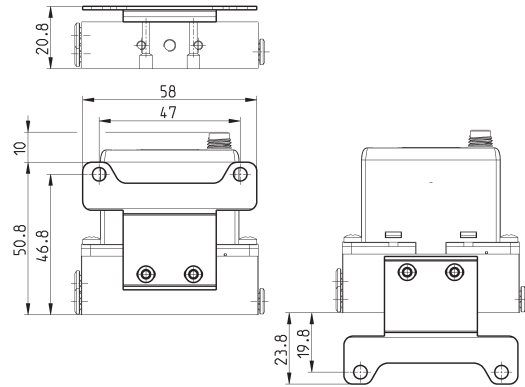

Mod.	
K8P-B1	

Circular M8 4-pole connectors, Female



With PU sheathing, non shielded cable.
Protection class: IP65

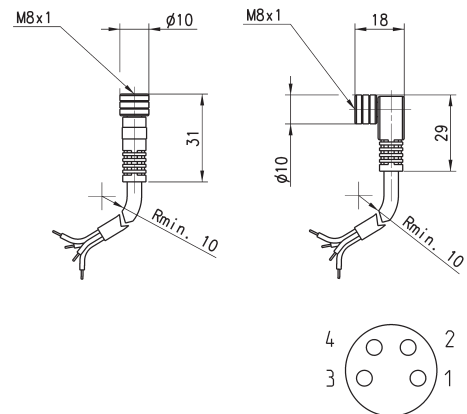

Mod.	Type of connector	Cable length (m)
CS-DF04EG-E200	straight	2
CS-DF04EG-E500	straight	5
CS-DR04EG-E200	right angle (90 degrees)	2
CS-DR04EG-E500	right angle (90 degrees)	5

Series MX-PRO proportional pressure regulator and proportional flow valve

Regulator and valve ports (standard and Manifold): G1/2
Regulator: with built-in pressure gauge or G1/8 threaded ports
Valve: without pressure gauge

SERIES MX-PRO PROPORTIONAL REGULATOR AND VALVE



Series MX-PRO electronic proportional pressure regulator is the result of combining advanced technology of Series K8P electronic proportional micro regulator, with reliability and high performance of Series MX2 modular regulators. This new regulator ensures high precision in pressure regulation, high flow rate and low consumption. Moreover, it can take the most of Series MX ease of assembly to provide particularly compact Manifolds.

- » High precision
- » Low electric consumption
- » High exhaust flow
- » Modular with Series MX
- » MANIFOLD and external servo pilot supply versions available
- » Suitable for use with oxygen

GENERAL DATA

	PROPORTIONAL PRESSURE REGULATOR	PROPORTIONAL FLOW VALVE
Construction	modular, compact, diaphragm type	modular, piston type
Materials	see material tables on the following pages	see material tables on the following pages
Ports	G1/2	G1/2
Mounting	vertical in-line, wall-mounting (by means of clamps)	vertical in-line, wall-mounting (by means of clamps)
Working pressure	0°C ÷ 50°C	0°C ÷ 50°C
Max inlet pressure	11 bar (10 bar), 4 bar (3 bar), 1.5 bar (1 bar), 8 bar (7 bar)	6 bar
Regulated pressure	0.5 ÷ 10 bar, 0.15 ÷ 3 bar, 0.05 ÷ 1 bar, 0.35 ÷ 7	-
Max servo-pilot pressure	4 bar (3 bar), 11 bar (10 bar), 1.5 bar (1 bar), 8 bar (7 bar)	4 bar (essential for the proper functioning)
Overpressure exhaust	with Relieving (standard) or without Relieving	NO
Nominal flow	see flow diagrams on the following pages	see flow diagrams on the following pages
Air specifications	filtered compressed air, non lubricated, class 7.4.4 according to ISO 8573.1 standard. If lubrication is necessary, please use only oils with maximum viscosity of 32 Cst and the version with external servo-pilot supply. The servo-pilot supply air quality class must be 7.4.4 according to ISO 8573.1 standard.	filtered compressed air, non lubricated, class 7.4.4 according to ISO 8573.1 standard. If lubrication is necessary, please use only oils with maximum viscosity of 32 Cst and the version with external servo-pilot supply. The servo-pilot supply air quality class must be 7.4.4 according to ISO 8573.1 standard.
Pressure gauge	with built-in pressure gauge (standard) with G1/8 port	without pressure gauge
Analogical input	0-10 V DC Ripple ≤ 0.2%; 4 – 20 mA	0-10 V DC Ripple ≤ 0.2%; 4 – 20 mA
Analogical output	0.5 - 9.5 V DC [Feedback]	not relevant
Electrical supply	24 V DC ±10%	24 V DC ±10%
Electrical connection	M8 4 Pin (Male)	M8 4 Pin (Male)
Linearity	≤ ± 1% FS	±4% FS
Hysteresis	±0.5% FS	±8% FS
Repeatability	±0.5% FS	±0.35% FS
Sensitivity	0.3% FS	5% FS
Protection class	IP51	IP51

CODING EXAMPLE

MX	2	-	1/2	-	R	CV	2	0	4	-	LH
-----------	----------	----------	------------	----------	----------	-----------	----------	----------	----------	----------	-----------

MX	SERIES
2	SIZE: 2 = G1/2
1/2	PORTS: 1/2 = G1/2
R	FUNCTIONING: R = pressure regulator M = Manifold pressure regulator V = flow valve W = Manifold flow valve
CV	COMMAND: CV = electrical command 0-10 V DC (regulator only) CA = electrical command 4-20 mA (regulator only) EV = electrical command 0-10 V DC with external servo pilot supply EA = electrical command 4-20 mA with external servo pilot supply
2	REGULATOR SETTING RANGE: 1 = working pressure 0 ÷ 3 bar 2 = working pressure 0 ÷ 10 bar 3 = working pressure 0 ÷ 1 bar 4 = working pressure 0 ÷ 7 bar VALVE SETTING RANGE: 8 = low flow 9 = high flow
0	DESIGN TYPE: 0 = relieving (regulator only) 1 = without relieving
4	PRESSURE GAUGE: 0 = without pressure gauge, with threaded port for gauges 2 = with built-in pressure gauge 0-6 bar (regulator only) 4 = with built-in pressure gauge 0-12 bar (regulator only)
LH	FLOW DIRECTION: = from left to right (standard) LH = from right to left
OX1	VERSIONS: = standard OX1 = for use with oxygen (in compliance with ASTM G93-03 Level E), FKM seals

Further details about the assembly of a single component with fixing flanges or wall-mounting can be found in the AIR TREATMENT catalogue, section SERIES MX ASSEMBLED FRL.

Series MX-PRO proportional pressure regulator - materials

R = proportional pressure regulator
M = Manifold proportional pressure regulator

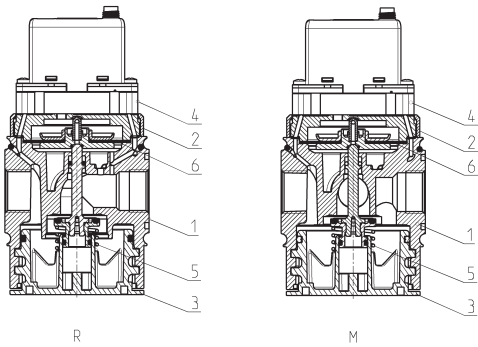

PARTS	MATERIALS, standard version	MATERIALS, oxygen version
1 = Body	Aluminium	Aluminium
2 = Covering	Polyacetal	PBT
3 = Valve holder plug	Polyacetal	PBT
4 = Upper base	Aluminium	Aluminium
5 = Lower spring	Stainless steel	Stainless steel
6 = Diaphragm	NBR	FKM
Seals	NBR	FKM

Series MX-PRO proportional flow valve - materials

V = proportional flow valve
W = Manifold proportional flow valve

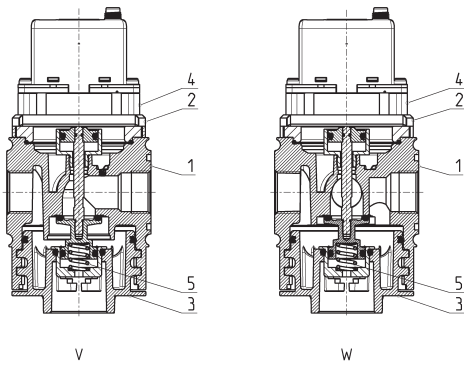

PARTS	MATERIALS, standard version	MATERIALS, oxygen version
1 = Body	Aluminium	Aluminium
2 = Covering	Polyacetal	PBT
3 = Valve holder plug	Polyacetal	PBT
4 = Upper base	Aluminium	Aluminium
5 = Lower spring	Stainless steel	Stainless steel
Seals	NBR	FKM

Series MX-PRO proportional pressure regulator



Male connector M8 4 poles
 Pin 1: +24 V DC (Power supply)
 Pin 2: Command analogical signal
 0-10 V DC or 4-20 mA
 Pin 3: 0 V (Ground) common also for
 the command signal
 Pin 4: Output analogical signal
 (according to the regulated
 pressure)

TABLE NOTES:

* = versions with or without external pilot supply

** = versions with our without relieving

LH = add LH at the end of the code for air inlet from the right to the left

5 red LED
 6 green LED

DRAWING NOTE:
 ** = in the versions with external servo pilot supply only (MX2-1/2-REV... and MX2-1/2-REA...)

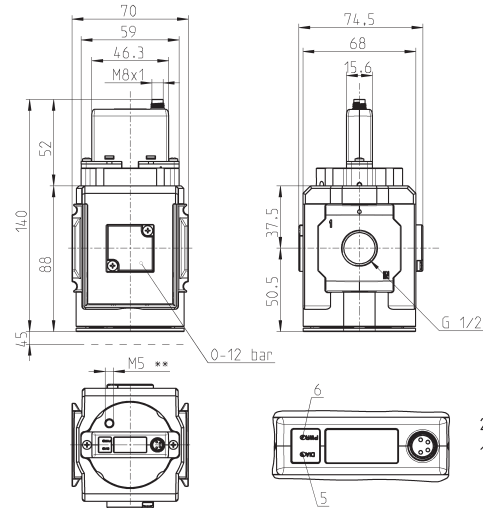

Mod.	Electrical command	Setting range	Pressure gauge
MX2-1/2-R ⁰ V1**0	0-10 V DC	0 ÷ 3 bar	without pressure gauge
MX2-1/2-R ⁰ V1**2	0-10 V DC	0 ÷ 3 bar	with built-in pressure gauge 0-6
MX2-1/2-R ⁰ V1**4	0-10 V DC	0 ÷ 3 bar	with built-in pressure gauge 0-12
MX2-1/2-R ⁰ V2**0	0-10 V DC	0 ÷ 10 bar	without pressure gauge
MX2-1/2-R ⁰ V2**2	0-10 V DC	0 ÷ 10 bar	with built-in pressure gauge 0-6
MX2-1/2-R ⁰ V2**4	0-10 V DC	0 ÷ 10 bar	with built-in pressure gauge 0-12
MX2-1/2-R ⁰ V3**0	0-10 V DC	0 ÷ 1 bar	without pressure gauge
MX2-1/2-R ⁰ V3**2	0-10 V DC	0 ÷ 1 bar	with built-in pressure gauge 0-6
MX2-1/2-R ⁰ V3**4	0-10 V DC	0 ÷ 1 bar	with built-in pressure gauge 0-12
MX2-1/2-R ⁰ V4**0	0-10 V DC	0 ÷ 7 bar	without pressure gauge
MX2-1/2-R ⁰ V4**2	0-10 V DC	0 ÷ 7 bar	with built-in pressure gauge 0-6
MX2-1/2-R ⁰ V4**4	0-10 V DC	0 ÷ 7 bar	with built-in pressure gauge 0-12
MX2-1/2-R ⁰ A1**0	4-20 mA	0 ÷ 3 bar	without pressure gauge
MX2-1/2-R ⁰ A1**2	4-20 mA	0 ÷ 3 bar	with built-in pressure gauge 0-6
MX2-1/2-R ⁰ A1**4	4-20 mA	0 ÷ 3 bar	with built-in pressure gauge 0-12
MX2-1/2-R ⁰ A2**0	4-20 mA	0 ÷ 10 bar	without pressure gauge
MX2-1/2-R ⁰ A2**2	4-20 mA	0 ÷ 10 bar	with built-in pressure gauge 0-6
MX2-1/2-R ⁰ A2**4	4-20 mA	0 ÷ 10 bar	with built-in pressure gauge 0-12
MX2-1/2-R ⁰ A3**0	4-20 mA	0 ÷ 1 bar	without pressure gauge
MX2-1/2-R ⁰ A3**2	4-20 mA	0 ÷ 1 bar	with built-in pressure gauge 0-6
MX2-1/2-R ⁰ A3**4	4-20 mA	0 ÷ 1 bar	with built-in pressure gauge 0-12
MX2-1/2-R ⁰ A4**0	4-20 mA	0 ÷ 7 bar	without pressure gauge
MX2-1/2-R ⁰ A4**2	4-20 mA	0 ÷ 7 bar	with built-in pressure gauge 0-6
MX2-1/2-R ⁰ A4**4	4-20 mA	0 ÷ 7 bar	with built-in pressure gauge 0-12
MX2-1/2-R ⁰ V1**0-OX1	0-10 V DC	0 ÷ 3 bar	without pressure gauge
MX2-1/2-R ⁰ V1**2-OX1	0-10 V DC	0 ÷ 3 bar	with built-in pressure gauge 0-6
MX2-1/2-R ⁰ V1**4-OX1	0-10 V DC	0 ÷ 3 bar	with built-in pressure gauge 0-12
MX2-1/2-R ⁰ V3**0-OX1	0-10 V DC	0 ÷ 1 bar	without pressure gauge
MX2-1/2-R ⁰ V3**2-OX1	0-10 V DC	0 ÷ 1 bar	with built-in pressure gauge 0-6
MX2-1/2-R ⁰ V3**4-OX1	0-10 V DC	0 ÷ 1 bar	with built-in pressure gauge 0-12
MX2-1/2-R ⁰ V4**0-OX1	0-10 V DC	0 ÷ 7 bar	without pressure gauge
MX2-1/2-R ⁰ V4**2-OX1	0-10 V DC	0 ÷ 7 bar	with built-in pressure gauge 0-6
MX2-1/2-R ⁰ V4**4-OX1	0-10 V DC	0 ÷ 7 bar	with built-in pressure gauge 0-12
MX2-1/2-R ⁰ A1**0-OX1	4-20 mA	0 ÷ 3 bar	without pressure gauge
MX2-1/2-R ⁰ A1**2-OX1	4-20 mA	0 ÷ 3 bar	with built-in pressure gauge 0-6
MX2-1/2-R ⁰ A1**4-OX1	4-20 mA	0 ÷ 3 bar	with built-in pressure gauge 0-12
MX2-1/2-R ⁰ A3**0-OX1	4-20 mA	0 ÷ 1 bar	without pressure gauge
MX2-1/2-R ⁰ A3**2-OX1	4-20 mA	0 ÷ 1 bar	with built-in pressure gauge 0-6
MX2-1/2-R ⁰ A3**4-OX1	4-20 mA	0 ÷ 1 bar	with built-in pressure gauge 0-12
MX2-1/2-R ⁰ A4**0-OX1	4-20 mA	0 ÷ 7 bar	without pressure gauge
MX2-1/2-R ⁰ A4**2-OX1	4-20 mA	0 ÷ 7 bar	with built-in pressure gauge 0-6
MX2-1/2-R ⁰ A4**4-OX1	4-20 mA	0 ÷ 7 bar	with built-in pressure gauge 0-12

PRESSURE REGULATOR FLOW DIAGRAMS - STANDARD VERSION

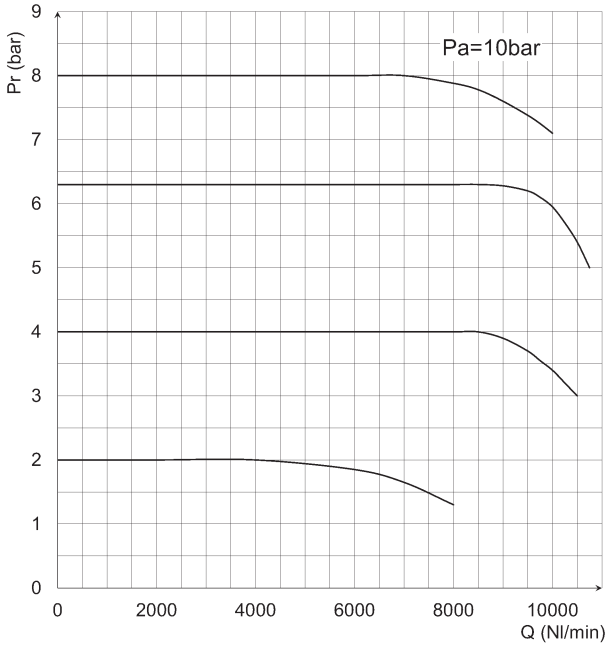

Pr = Regulated pressure
Q = Flow

Pa = Inlet pressure

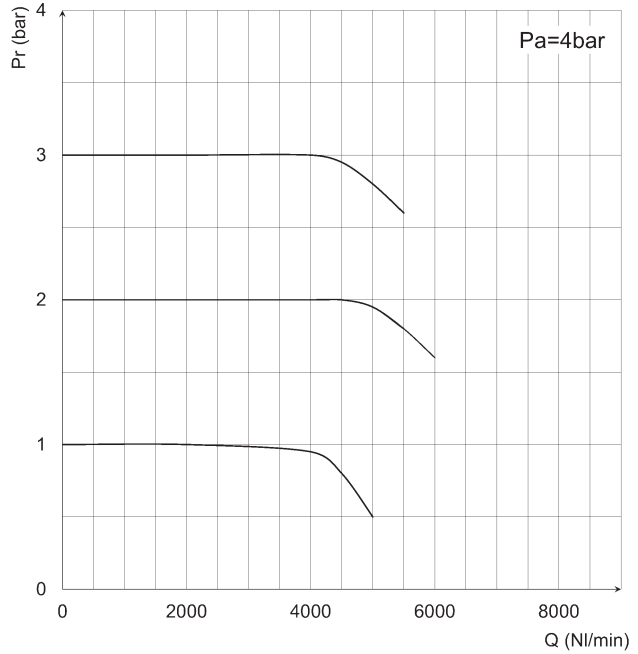

Pr = Regulated pressure
Q = Flow

Pa = Inlet pressure

EXHAUST FLOW DIAGRAM AND PNEUMATIC SYMBOLS

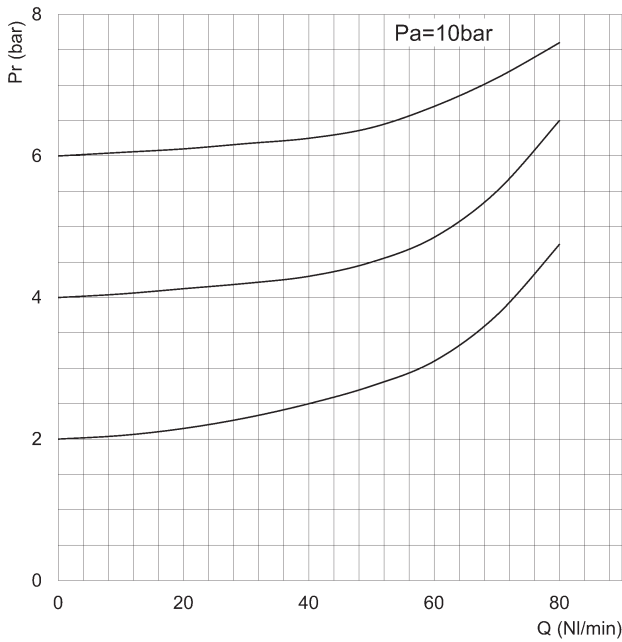

Pr = Regulated pressure
Q = Flow

Pa = Inlet pressure

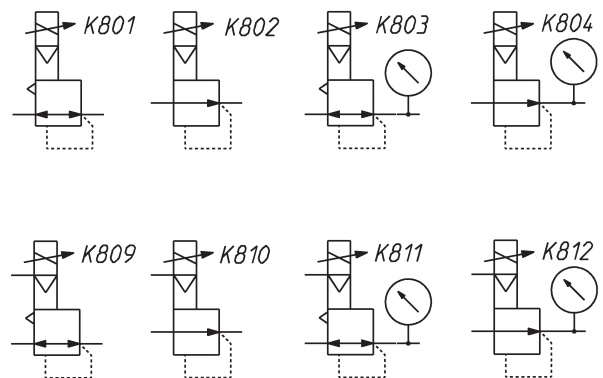

- K801 = relieving, electrical command
- K802 = NO relieving, electrical command
- K803 = relieving, electrical command, built-in pressure gauge
- K804 = NO relieving, electrical command, built-in pressure gauge
- K809 = relieving, electrical command, ext. servo pilot supply
- K810 = NO reliev., electrical command, ext. servo pilot supply
- K811 = reliev., el. com., built-in pr. gauge, ext. servo pilot supply
- K812 = NO reliev., el. com., built-in pr. gauge, ext. servo pilot sup.

Series MX-PRO proportional pressure regulator



Male connector M8 4 poles
 Pin 1: +24 V DC (Power supply)
 Pin 2: Command analogical signal
 0-10 V DC or 4-20 mA
 Pin 3: 0 V (Ground) common also for
 the command signal
 Pin 4: Output analogical signal
 (according to the regulated
 pressure)

TABLE NOTES:

* = versions with or without external pilot supply

** = versions with our without relieving

LH = add LH at the end of the code for air inlet from the right to the left

5 red LED
 6 green LED

DRAWING NOTE:

** = in the versions with external servo pilot supply only (MX2-1/2-REV... and MX2-1/2-REA...)

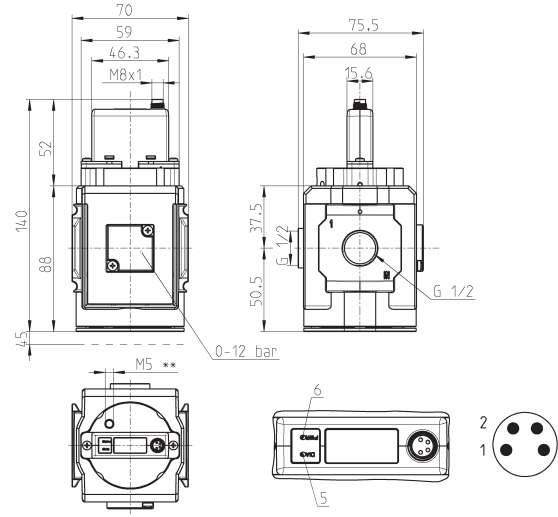

Mod.	Electrical command	Setting range	Pressure gauge
MX2-1/2-M [*] V1 ^{**} 0	0-10 V DC	0 ÷ 3 bar	without pressure gauge
MX2-1/2-M [*] V1 ^{**} 2	0-10 V DC	0 ÷ 3 bar	with built-in pressure gauge 0-6
MX2-1/2-M [*] V1 ^{**} 4	0-10 V DC	0 ÷ 3 bar	with built-in pressure gauge 0-12
MX2-1/2-M [*] V2 ^{**} 0	0-10 V DC	0 ÷ 10 bar	without pressure gauge
MX2-1/2-M [*] V2 ^{**} 2	0-10 V DC	0 ÷ 10 bar	with built-in pressure gauge 0-6
MX2-1/2-M [*] V2 ^{**} 4	0-10 V DC	0 ÷ 10 bar	with built-in pressure gauge 0-12
MX2-1/2-M [*] V3 ^{**} 0	0-10 V DC	0 ÷ 1 bar	without pressure gauge
MX2-1/2-M [*] V3 ^{**} 2	0-10 V DC	0 ÷ 1 bar	with built-in pressure gauge 0-6
MX2-1/2-M [*] V3 ^{**} 4	0-10 V DC	0 ÷ 1 bar	with built-in pressure gauge 0-12
MX2-1/2-M [*] V4 ^{**} 0	0-10 V DC	0 ÷ 7 bar	without pressure gauge
MX2-1/2-M [*] V4 ^{**} 2	0-10 V DC	0 ÷ 7 bar	with built-in pressure gauge 0-6
MX2-1/2-M [*] V4 ^{**} 4	0-10 V DC	0 ÷ 7 bar	with built-in pressure gauge 0-12
MX2-1/2-M [*] A1 ^{**} 0	4-20 mA	0 ÷ 3 bar	without pressure gauge
MX2-1/2-M [*] A1 ^{**} 2	4-20 mA	0 ÷ 3 bar	with built-in pressure gauge 0-6
MX2-1/2-M [*] A1 ^{**} 4	4-20 mA	0 ÷ 3 bar	with built-in pressure gauge 0-12
MX2-1/2-M [*] A2 ^{**} 0	4-20 mA	0 ÷ 10 bar	without pressure gauge
MX2-1/2-M [*] A2 ^{**} 2	4-20 mA	0 ÷ 10 bar	with built-in pressure gauge 0-6
MX2-1/2-M [*] A2 ^{**} 4	4-20 mA	0 ÷ 10 bar	with built-in pressure gauge 0-12
MX2-1/2-M [*] A3 ^{**} 0	4-20 mA	0 ÷ 1 bar	without pressure gauge
MX2-1/2-M [*] A3 ^{**} 2	4-20 mA	0 ÷ 1 bar	with built-in pressure gauge 0-6
MX2-1/2-M [*] A3 ^{**} 4	4-20 mA	0 ÷ 1 bar	with built-in pressure gauge 0-12
MX2-1/2-M [*] A4 ^{**} 0	4-20 mA	0 ÷ 7 bar	without pressure gauge
MX2-1/2-M [*] A4 ^{**} 2	4-20 mA	0 ÷ 7 bar	with built-in pressure gauge 0-6
MX2-1/2-M [*] A4 ^{**} 4	4-20 mA	0 ÷ 7 bar	with built-in pressure gauge 0-12
MX2-1/2-M [*] V1 ^{**} 0-OX1	0-10 V DC	0 ÷ 3 bar	without pressure gauge
MX2-1/2-M [*] V1 ^{**} 2-OX1	0-10 V DC	0 ÷ 3 bar	with built-in pressure gauge 0-6
MX2-1/2-M [*] V1 ^{**} 4-OX1	0-10 V DC	0 ÷ 3 bar	with built-in pressure gauge 0-12
MX2-1/2-M [*] V3 ^{**} 0-OX1	0-10 V DC	0 ÷ 1 bar	without pressure gauge
MX2-1/2-M [*] V3 ^{**} 2-OX1	0-10 V DC	0 ÷ 1 bar	with built-in pressure gauge 0-6
MX2-1/2-M [*] V3 ^{**} 4-OX1	0-10 V DC	0 ÷ 1 bar	with built-in pressure gauge 0-12
MX2-1/2-M [*] V4 ^{**} 0-OX1	0-10 V DC	0 ÷ 7 bar	without pressure gauge
MX2-1/2-M [*] V4 ^{**} 2-OX1	0-10 V DC	0 ÷ 7 bar	with built-in pressure gauge 0-6
MX2-1/2-M [*] V4 ^{**} 4-OX1	0-10 V DC	0 ÷ 7 bar	with built-in pressure gauge 0-12
MX2-1/2-M [*] A1 ^{**} 0-OX1	4-20 mA	0 ÷ 3 bar	without pressure gauge
MX2-1/2-M [*] A1 ^{**} 2-OX1	4-20 mA	0 ÷ 3 bar	with built-in pressure gauge 0-6
MX2-1/2-M [*] A1 ^{**} 4-OX1	4-20 mA	0 ÷ 3 bar	with built-in pressure gauge 0-12
MX2-1/2-M [*] A3 ^{**} 0-OX1	4-20 mA	0 ÷ 1 bar	without pressure gauge
MX2-1/2-M [*] A3 ^{**} 2-OX1	4-20 mA	0 ÷ 1 bar	with built-in pressure gauge 0-6
MX2-1/2-M [*] A3 ^{**} 4-OX1	4-20 mA	0 ÷ 1 bar	with built-in pressure gauge 0-12
MX2-1/2-M [*] A4 ^{**} 0-OX1	4-20 mA	0 ÷ 7 bar	without pressure gauge
MX2-1/2-M [*] A4 ^{**} 2-OX1	4-20 mA	0 ÷ 7 bar	with built-in pressure gauge 0-6
MX2-1/2-M [*] A4 ^{**} 4-OX1	4-20 mA	0 ÷ 7 bar	with built-in pressure gauge 0-12

PRESSURE REGULATOR FLOW DIAGRAMS - MANIFOLD VERSION

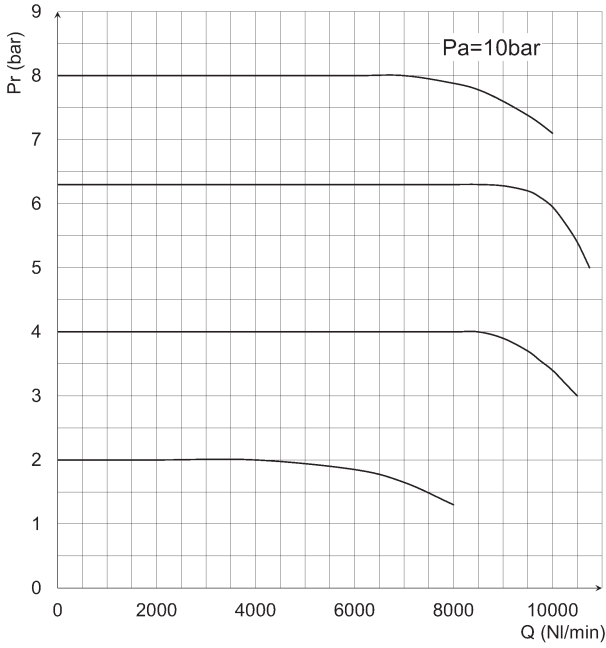

Pr = Regulated pressure
Q = Flow

Pa = Inlet pressure

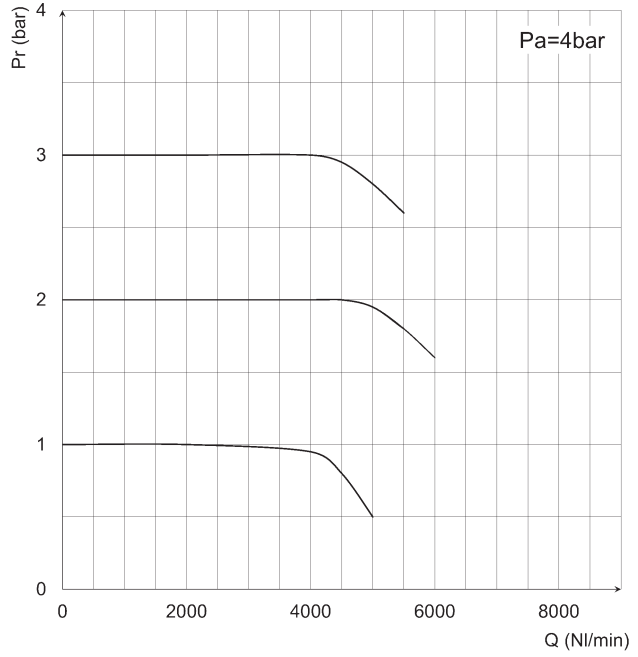

Pr = Regulated pressure
Q = Flow

Pa = Inlet pressure

EXHAUST FLOW DIAGRAM - MANIFOLD VERSION

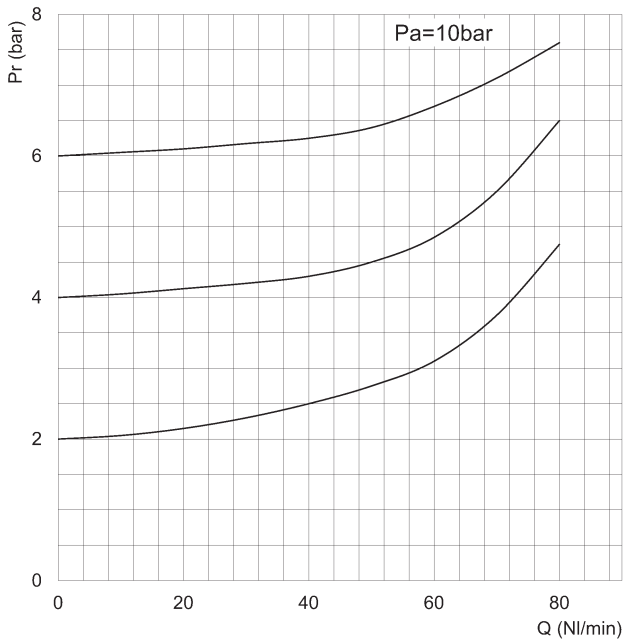

Pr = Regulated pressure
Q = Flow

Pa = Inlet pressure

PNEUMATIC SYMBOLS - MANIFOLD VERSION

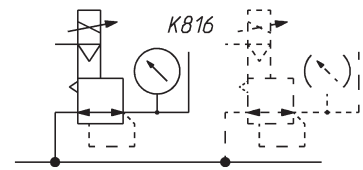
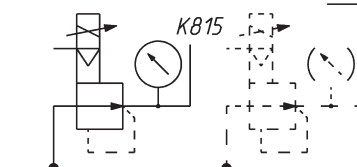
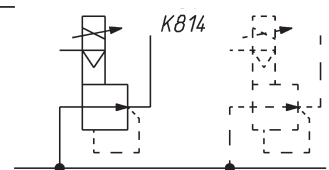
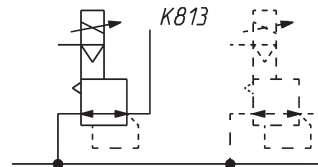
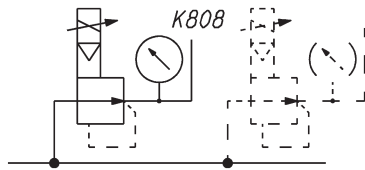
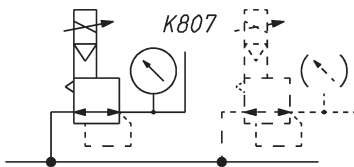
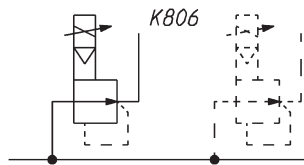
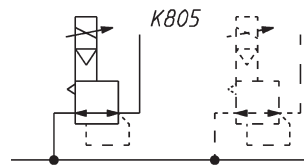

- K805 = MANIFOLD reg., relieving, electrical command
- K806 = MANIFOLD reg., NO relieving, electrical command
- K807 = MANIFOLD reg., relieving, electrical command and built-in pressure gauge
- K808 = MANIFOLD reg., NO relieving, electrical command and built-in pressure gauge

- K813 = MANIFOLD reg., relieving, electrical command, and external servo pilot supply
- K814 = MANIFOLD reg., NO relieving, electrical command, and external servo pilot supply
- K815 = MANIFOLD reg., relieving, electrical command, built-in pressure gauge and external servo pilot supply
- K816 = MANIFOLD reg., NO relieving, electrical command, built-in pressure gauge and external servo pilot supply

Series MX-PRO proportional flow valve



- Male connector M8 4 poles
- Pin 1: +24 V DC (Power supply)
- Pin 2: Command analogical signal
0-10 V DC or 4-20 mA
- Pin 3: 0 V (Ground) common also
for the command signal
- Pin 4: Output analogical signal
(according to the
regulated pressure)
- 5 red LED
- 6 green LED

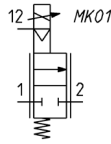
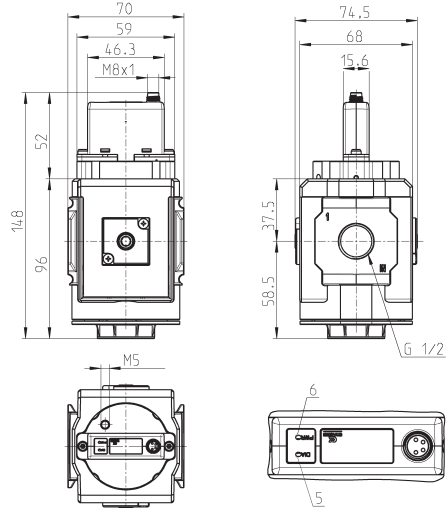

Mod.	Electrical command	Setting range
MX2-1/2-VEV810	0-10 V DC	low flow
MX2-1/2-VEA810	4-20 mA	low flow
MX2-1/2-VEV910	0-10 V DC	high flow
MX2-1/2-VEA910	4-20 mA	high flow
MX2-1/2-VEV810-LH	0-10 V DC	low flow
MX2-1/2-VEA810-LH	4-20 mA	low flow
MX2-1/2-VEV910-LH	0-10 V DC	high flow
MX2-1/2-VEA910-LH	4-20 mA	high flow
MX2-1/2-VEV8100X1	0-10 V DC	low flow
MX2-1/2-VEA8100X1	4-20 mA	low flow
MX2-1/2-VEV9100X1	0-10 V DC	high flow
MX2-1/2-VEA9100X1	4-20 mA	high flow
MX2-1/2-VEV810-LHOX1	0-10 V DC	low flow
MX2-1/2-VEA810-LHOX1	4-20 mA	low flow
MX2-1/2-VEV910-LHOX1	0-10 V DC	high flow
MX2-1/2-VEA910-LHOX1	4-20 mA	high flow

VALVE FLOW DIAGRAMS

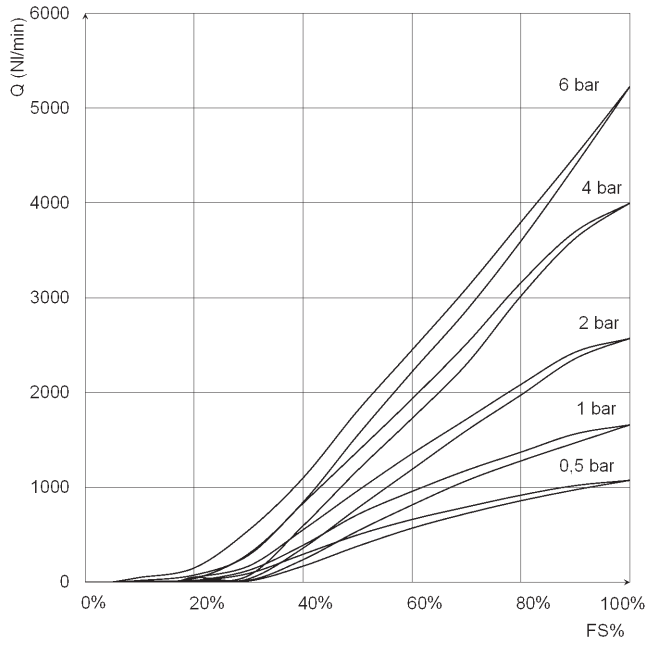

Low flow version

Q (NL/min) = flow
 FS% = full scale command signal

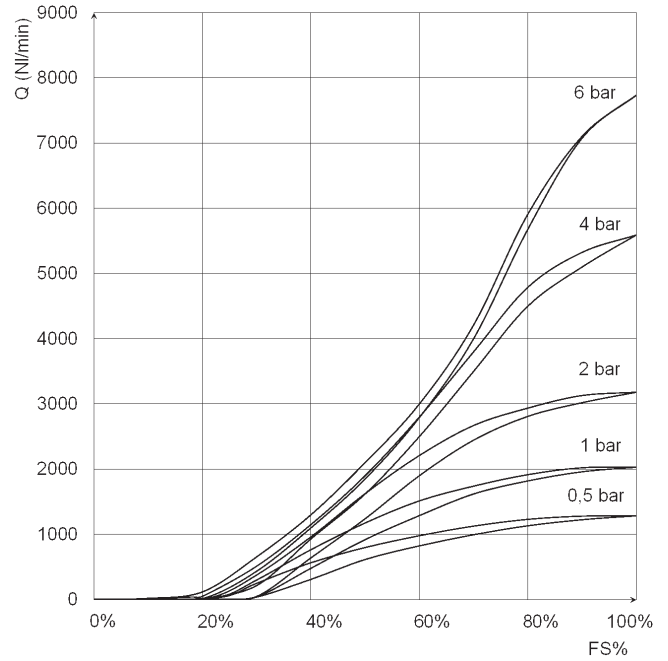

High flow

Q (NL/min) = flow
 FS% = full scale command signal

Series MX-PRO Manifold proportional flow valve



- Male connector M8 4 poles
- Pin 1: +24 V DC (Power supply)
- Pin 2: Command analogical signal
0-10 V DC or 4-20 mA
- Pin 3: 0 V (Ground) common also
for the command signal
- Pin 4: Output analogical signal
(according to the
regulated pressure)
- 5 red LED
- 6 green LED

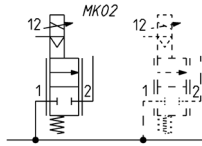
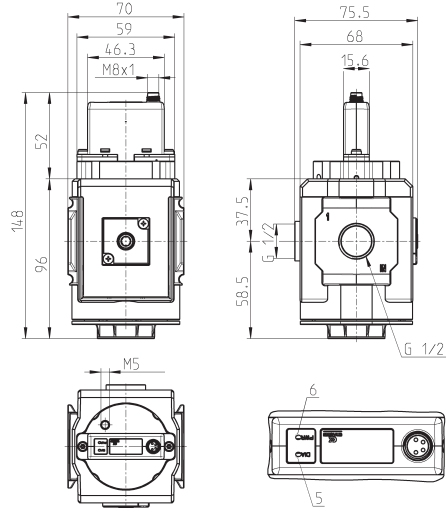

SERIES MX-PRO PROPORTIONAL REGULATOR AND VALVE

Mod.	Electrical command	Setting range
MX2-1/2-WEV810	0-10 V DC	low flow
MX2-1/2-WEA810	4-20 mA	low flow
MX2-1/2-WEV910	0-10 V DC	high flow
MX2-1/2-WEA910	4-20 mA	high flow
MX2-1/2-WEV810-LH	0-10 V DC	low flow
MX2-1/2-WEA810-LH	4-20 mA	low flow
MX2-1/2-WEV910-LH	0-10 V DC	high flow
MX2-1/2-WEA910-LH	4-20 mA	high flow
MX2-1/2-WEV810OX1	0-10 V DC	low flow
MX2-1/2-WEA810OX1	4-20 mA	low flow
MX2-1/2-WEV910OX1	0-10 V DC	high flow
MX2-1/2-WEA910OX1	4-20 mA	high flow
MX2-1/2-WEV810-LHOX1	0-10 V DC	low flow
MX2-1/2-WEA810-LHOX1	4-20 mA	low flow
MX2-1/2-WEV910-LHOX1	0-10 V DC	high flow
MX2-1/2-WEA910-LHOX1	4-20 mA	high flow

VALVE FLOW DIAGRAMS - MANIFOLD VERSION

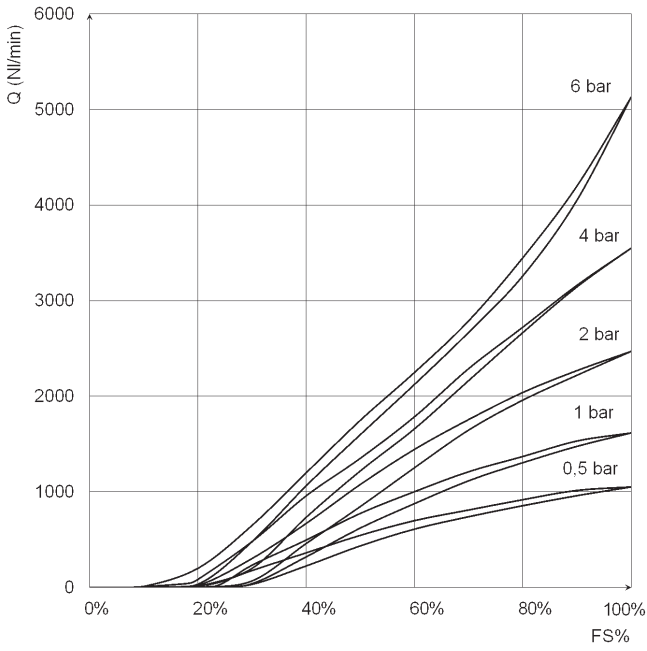

Low flow version

Q (NL/min) = flow
FS% = full scale command signal

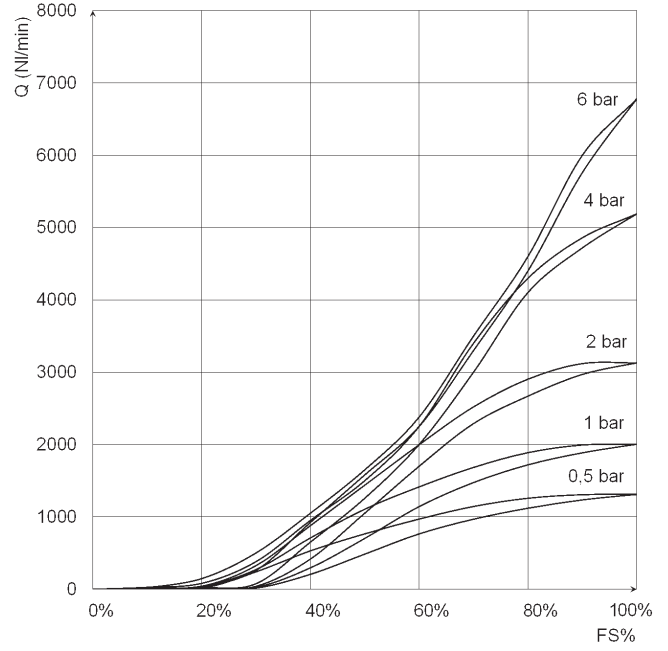

High flow version

Q (NL/min) = flow
FS% = full scale command signal

Flow characteristic curve of a proportional valve

Q% = flow
FS% = full scale command signal

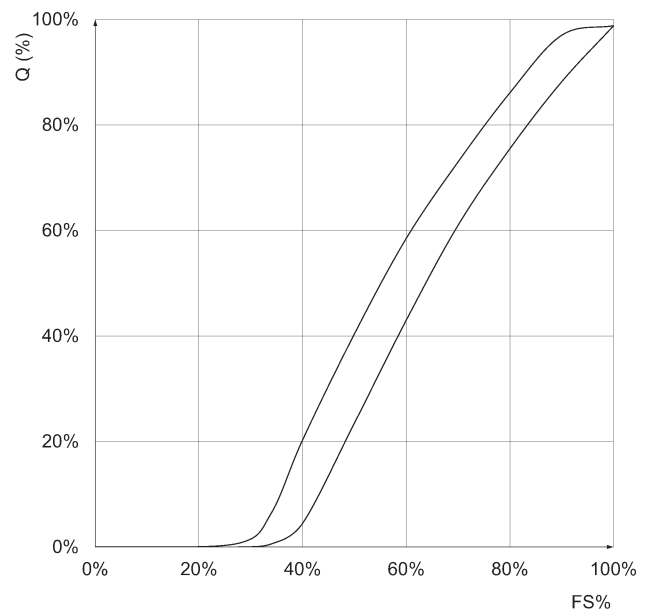

Valve maximum flow and response times

Maximum flow according to the inlet pressure

DIAGRAM LEGEND:

Q = flow (NL/min)
P = inlet pressure (bar)

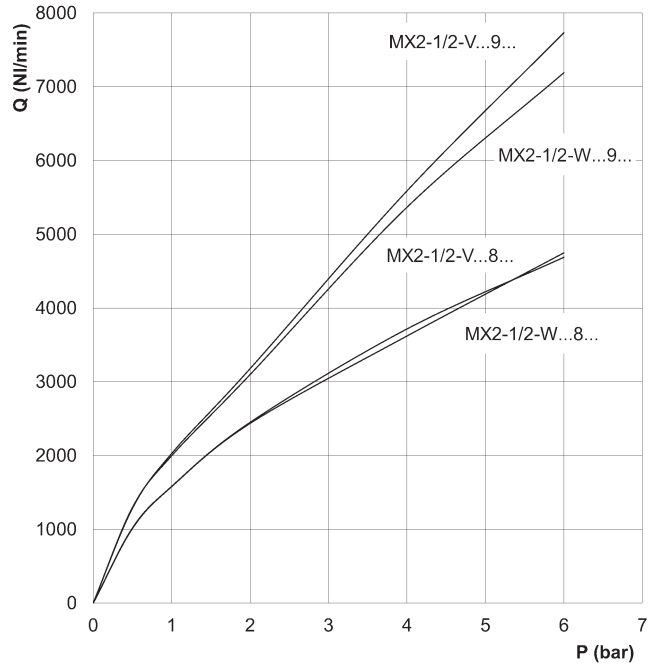

Pin	Type	Standard	Flow at steady speed [NL/min]	Command [V]		Load response time (ms)				Exhaust response time (ms)			
						0-10%	0-50%	0-90%	0-99%	0-10%	0-50%	0-90%	0-99%
2 bar	Low flow	Standard	915	6	351	452.4	967.2	6240	171.6	284.7	487.5	624	
		Manifold	1000	6.3	327.6	421.2	951.6	6162	249.6	366.6	577.2	780	
	High flow	Standard	960	4.7	331.5	444.6	1279.2	6942	245.7	329.16	526.5	702	
		Manifold	960	4.2	313	420	1156	9700	200	340	540	800	
4 bar	Low flow	Standard	952	5.4	319.8	436.8	1029.6	7410	187.2	304.2	491.4	624	
		Manifold	925	5.3	284.7	408.72	1474.2	6240	237.9	370.5	557.7	897	
	High flow	Standard	970	4.4	279.24	429	1177.8	7878	225	351	526.5	741	
		Manifold	940	3.8	230	400	1680	8500	175	360	580	900	

Set flow: about 1000 NL/min

Rapid clamp kit



The kit MX2-X is supplied with:
1 rapid clamp, 1 O-ring OR 3125 *,
2 exagonal nuts M5, 2 screws M5x69.

The kit MX2-Z is supplied with:
1 rapid clamp, 1 O-ring OR 3125 *,
1 exagonal nut M5, 1 screw M5x69,
1 screw M5x85 for wall fixing.

* it can be ordered separately (cod. 160-39-11/19)

Materials: technopolymer clamp, NBR O-ring,
zinc-plated steel nuts and screws.

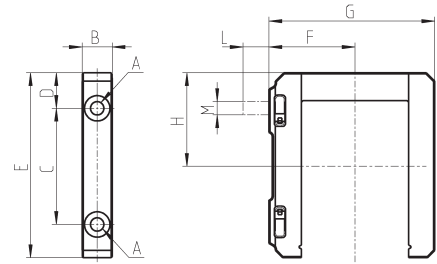

DIMENSIONS											
Mod.	A	B	C	D	E	F	G	H	L	M	Notes
MX2-X	5.2	12	46	14	73.5	37.5	70.5	37	-	-	
MX2-Z	5.2	12	46	14	73.5	37.5	70.5	37	14	M5	kit with wall fixing screw

Rapid clamp kit with wall fixing brackets



The kit MX2-Y is supplied with:
1 wall rapid clamp, 1 O-ring OR 3125 **, 2 exagonal nuts,
2 screws M5x69.

** it can be separately ordered (cod. 160-39-11/19)

Materials: technopolymer clamp, NBR O-ring,
zinc-plated steel nuts and screws.

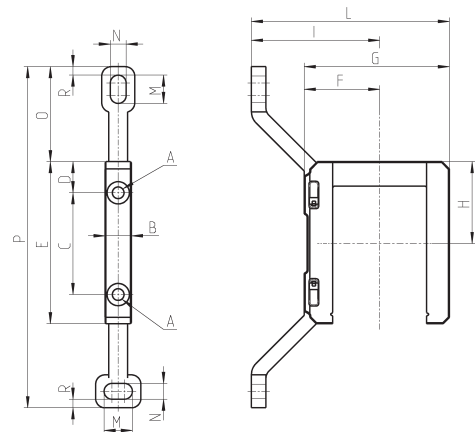

Mod.	A	B	C	D	E	F	G	H	I	L	M	N	O	P	R
MX2-Y	5,2	12	46	14	73,5	32,5	70,5	37	70,5	103	12	6,5	42	152	4

Terminal flanges (IN/OUT)

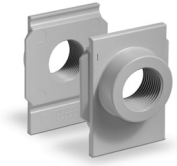

The kit is supplied with:

- 1 flange INLET side
- 1 flange OUTLET side

Materials: painted aluminium flanges.

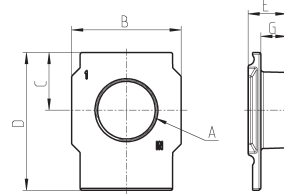

Mod.	A	B	C	D	E	G
MX2-1/2-FL	G1/2	50	26,5	63,5	17	11

Rapid clamps kit + flanges



Mod.	The kit is supplied with:
MX2-1/2-HH	1x MX2-1/2-FL + 2x MX2-X
MX2-1/2-JJ	1x MX2-1/2-FL + 2x MX2-Z

Rapid clamps kit with wall fixing brackets + flanges



Mod.	The kit is supplied with:
MX2-1/2-KK	1x MX2-1/2-FL + 2x MX2-Y

Block for pressure gauge fixing



The kit is supplied with:
 1 block
 1 grain
 2 screws
 1 seal

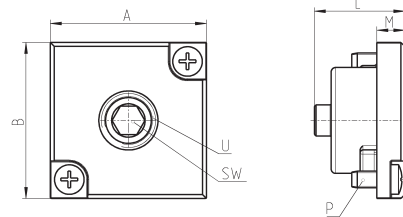

DIMENSIONS							
Mod.	A	B	L	M	P	U	SW
MX2-R26/1-P	28	28	16.5	5	M3X7	1/8	5

O-ring for assembling

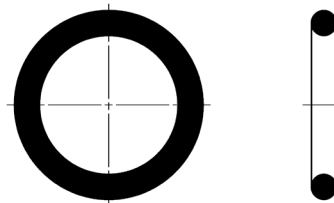

Mod.	O-ring	For assembly
160-39-11/19	OR 3125	MX2

Circular M8 4-pole connectors, Female

With PU sheathing, non shielded cable.
Protection class: IP65

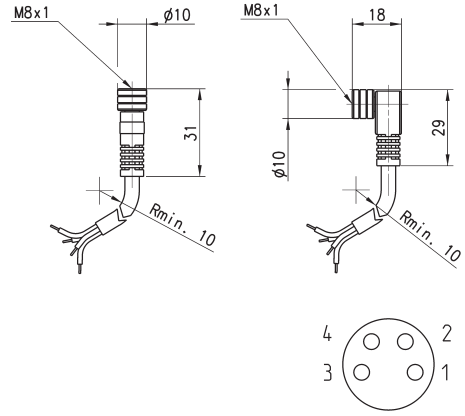

Mod.	Type of connector	Cable length (m)
CS-DF04EG-E200	straight	2
CS-DF04EG-E500	straight	5
CS-DR04EG-E200	right angle (90 degrees)	2
CS-DR04EG-E500	right angle (90 degrees)	5

New

Series PRE proportional pressure regulator with CoilVision technology

Two sizes available: PRE1 and PRE2
Ports G1/4 - G3/8 - 1/4NPTF

COILVISION TECHNOLOGY  



The Series PRE proportional pressure regulator is equipped with a new technology, CoilVision, which constantly monitors the operation of the solenoids in the regulator to assess their health status.

All data generated by the regulator can be transmitted wirelessly, for logging, aggregation and analysis and can be viewed through the UVIX software, downloadable from the Camozzi Catalogue website.

The Series PRE is available in two sizes and in different configurations, including IO-Link connectivity. As well as the standard options with and without display, there is a version with an integral exhaust valve, which enables the system to exhaust even without a power supply.

A manifold version enables the control of several outlets with only one inlet, while a version with an additional external sensor connection enables pressure control at any point in the system.

- » "CoilVision technology" for diagnostics and health status analysis
- » Compatible with OXYGEN
- » Control parameters can be customised
- » Configuration flexibility
- » IO-Link version
- » Version with and without display
- » Manifold version
- » Version with integrated exhaust valve UL CSA certificate
- » 5 bit PreSet version for a maximum of 32 different pressures
- » Modular with Series MD

GENERAL DATA

Standard of reference	CE; Rosh; UL-CSA		
Controlled quantity	Pressure		
Number of ways	3		
Flow (Qn)	PRE104 - 1100 NI/min	PRE238 - 4600 NI/min	
Media	Filtered and non-lubricated compressed air of class 7.4.4 according to ISO 8573.1. Inert gases and oxygen		
Min & max regulated pressure (bar)	0 - 1 bar (0-14,5 PSI)(B) 0,03 - 4 bar (0,43-58 PSI) (E)	0,05 - 10,3 bar (0,72-150 PSI)(D) 0,05 - 7 bar (0,72-101,5 PSI) (G)	0,05 - 6 bar (0,72-87 PSI)(F)
Maximum inlet pressure	2 bar (B) 5 bar (E)	11 bar (D); (G) ed (F)	
External sensor (optional)	input signal 0-10 V DC or 4-20 mA		
Resolution (% FS)	0,3 (Size 1) 0,6 (Size 2)		
Fluid temperature (min and max °C)	0 - 50 °C		
Environmental temperature (min and max °C)	0 - 50 °C		
Pneumatic ports	G1/4 - G3/8 - 1/4NPTF		
Materials	body: aluminium - cover: technopolymer - seals: NBR or FKM		
Supply voltage (V)	24 V DC		
Command signal	0-10V (2); 4-20 mA (4); 5 bit Digital (D); IO-Link (I)		
Hysteresis (% FS)	0,5% (Size 1) 0.7% (Size 2)		
Power consumption	Max 0,5A (Envisage a power supply of at least 1A)		
Type of electrical connection	M12 5 Pin Male (IO-Link) M12 8 Pin Male (Analog and PreSet) M12 12 Pin Male (version with external sensor)		
IP protection class	IP65		
Repeatability (% FS)	0,4		
Linearity (% FS)	0,4		
Modularity	with Series MD		
PRE in IO-Link version	V1.1 according to standard IEC 61131-9 / 61131-2		
Feedback signal	0-5 V DC and 4-20 mA (always present in the version with analog command signal (2) (4))		

CODING EXAMPLE

PRE	1	04	-	D	D	5	I	2	E	-	00		
------------	----------	-----------	----------	----------	----------	----------	----------	----------	----------	----------	-----------	--	--

PRE	SERIES
1	Size: 1 = Size 1 2 = Size 2
04	CONNECTION PORTS: 04 = G1/4 38 = G3/8 (only size 2) M4 = G1/4 Manifold 14 = NPTF 1/4 (only size 1) N4 = 1/4 NPTF Manifold
D	DISPLAY: E = without display D = with display
D	WORKING PRESSURE (1 bar = 14,5 psi): B = 0-1 bar E = 0-4 bar F = 0-6 bar (standard for OX1 version with internal servo pilot supply) G = 0-7 bar D = 0-10,3 bar 2 = external sensor 0-10 or 4-20 mA (only with command signal 2 or 4) The external sensor is not included with the regulator. It must be bought separately.
5	VALVE FUNCTIONS: 5 = 3 ways (standard) 6 = integrated exhaust valve (maximum working pressure B, E or G) 7 = 3 ways (connection 3 conveyable, optional for size 1, standard for size 2) 8 = integrated exhaust valve (connection 3 conveyable, optional for size 1, standard for size 2. Maximum working pressure B, E or G)
I	PILOT SUPPLY: I = Internal E = External
2	COMMAND SIGNAL: 2 = 0-10 V 4 = 4-20 mA D = 5 bit Preset for 32 different pressure values I = IO-Link
E	DIGITAL FEEDBACK SIGNAL: E = error signal (only with command signal 2, 4, D) P = pressure switch (only with command signal 2, 4, D) W = window (only with command signal 2, 4, D) N = no digital output (only with IO-Link version)
00	CABLE LENGTH: 00 = no cable 2F = 2 mt straight 2R = 2 mt 90° 5F = 5 mt straight 5R = 5 mt 90° 2FC = 2 mt straight shielded 2RC = 2 mt 90° shielded 5FC = 5 mt straight shielded 5RC = 5 mt 90° shielded
	ACCESSORY DIAGNOSTICS: = without diagnostics (only with command signal 2, 4, D) 0D = with Basic diagnostics (only with command signal 2, 4, D) 0W = Wireless connection (only with command signal 2, 4, D) DW = Wireless connection+ CoilVision diagnostics (only with command signal 2, 4, D) 1D = IO-Link + CoilVision diagnostics (only with IO-Link version)
	CERTIFICATIONS: = no certification OX1 = compatible with oxygen

SERIES PRE - COILVISION DIAGNOSTICS



SERIES PRE - PROPORTIONAL REGULATORS

The CoilVision function, (optional in the Series PRE proportional regulators), has the aim to constantly monitor the operation of the individual solenoids in the regulator, this is possible thanks to specific electronics and algorithms patented by Camozzi.

This option allows to monitor the health and operating status of the pilot solenoids, indicating any discrepancies compared to the ideal operating conditions. The information obtained allows the user to plan, in advance, any interventions on the most essential devices.

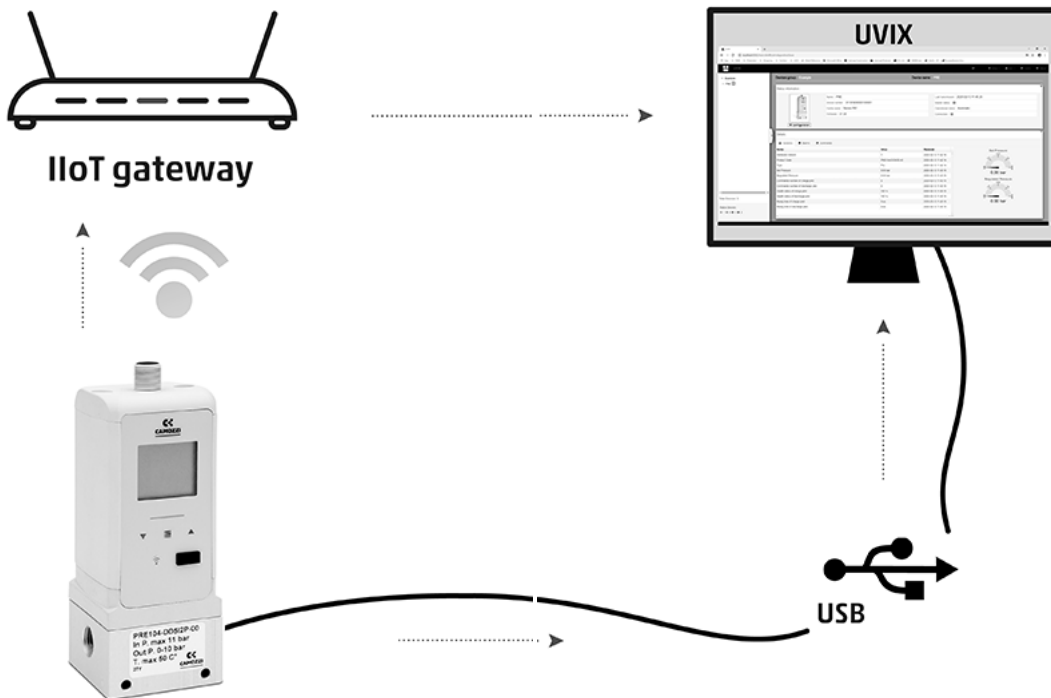

Through this function, you also have control over the internal temperature and the actual working hours of the regulator. All these indications can be read by the "UVIX" supervisor software, that can be downloaded free of charge from the Camozzi website in the products section.

Thanks to UVIX, data can be read via USB port or via wireless connection, where present. Devices equipped with an IO-Link connection can also make the data available to the PLC through the IO-Link master.

DIMENSIONAL CHARACTERISTICS SERIES PRE SIZE 1

SERIES PRE PROPORTIONAL REGULATORS

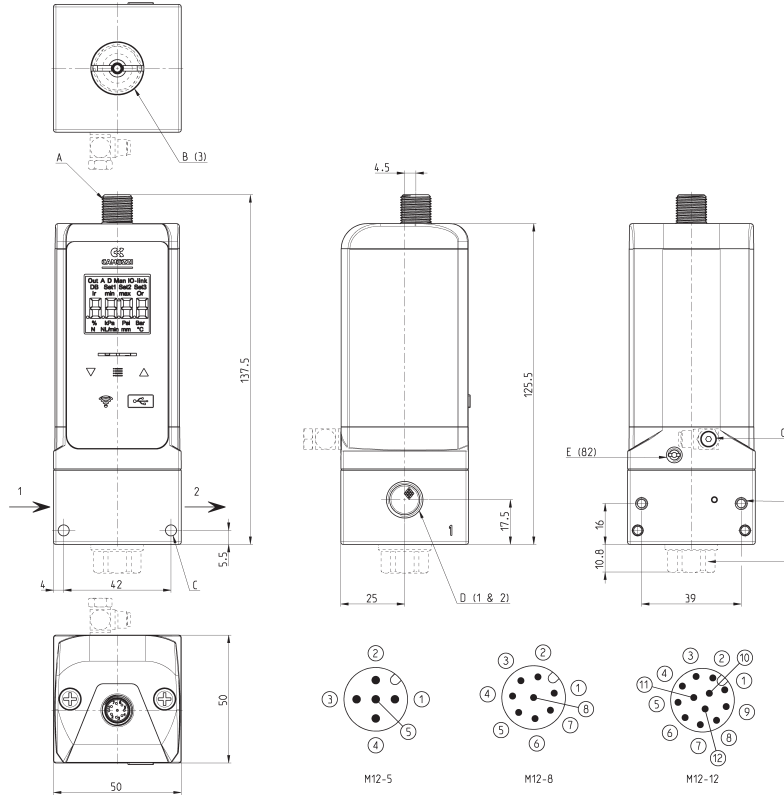

Mod.	A	B (3)	C	D (1 & 2)	E (82)	F	G	H
PRE 1	Electrical connection M12	Regulator exhaust	Fixing holes $\varnothing 4,3$	Port 1/4 or NPTF)	(GAS Exhaust of pilot solenoids M5	Fixing holes M4	External servo-pilot M5	Valve function (7 - 8) G 1/4

M12 - 5 (pin male) for I/O Link version	M12 - 8 (pin male) for analog version	M12 - 12 (pin male) for version with external sensor connection
--------------------------------------------	------------------------------------------	--------------------------------------------------------------------

DIMENSIONAL CHARACTERISTICS SERIES PRE SIZE 2

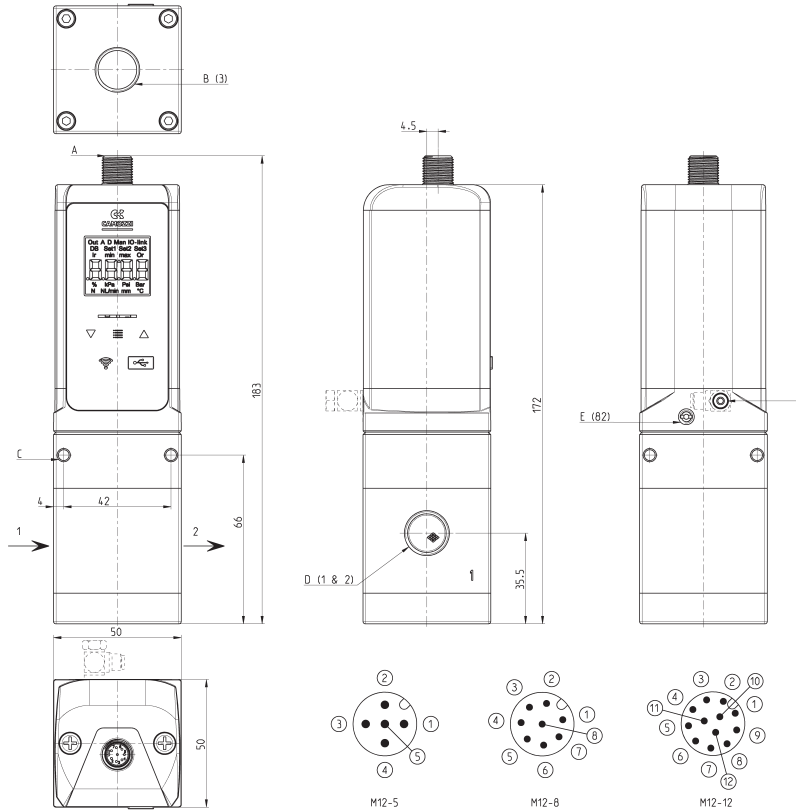

SERIES PRE PROPORTIONAL REGULATORS

Mod.	A	B (3)	C	D (1 & 2)	E (82)	F
PRE 2	Electrical Connection M12	Regulator exhaust G3/8	Fixing holes Ø4,3	Ports G 3/8 or G 1/4	Exhaust of pilot solenoids M5	External servo-pilot M5

M12 - 5 (pin male)
for I/O Link version

M12 - 8 (pin male)
for analog version

M12 - 12 (pin male)
for version with external sensor connection

DIMENSIONAL CHARACTERISTICS SERIES PRE SIZE 1 MANIFOLD

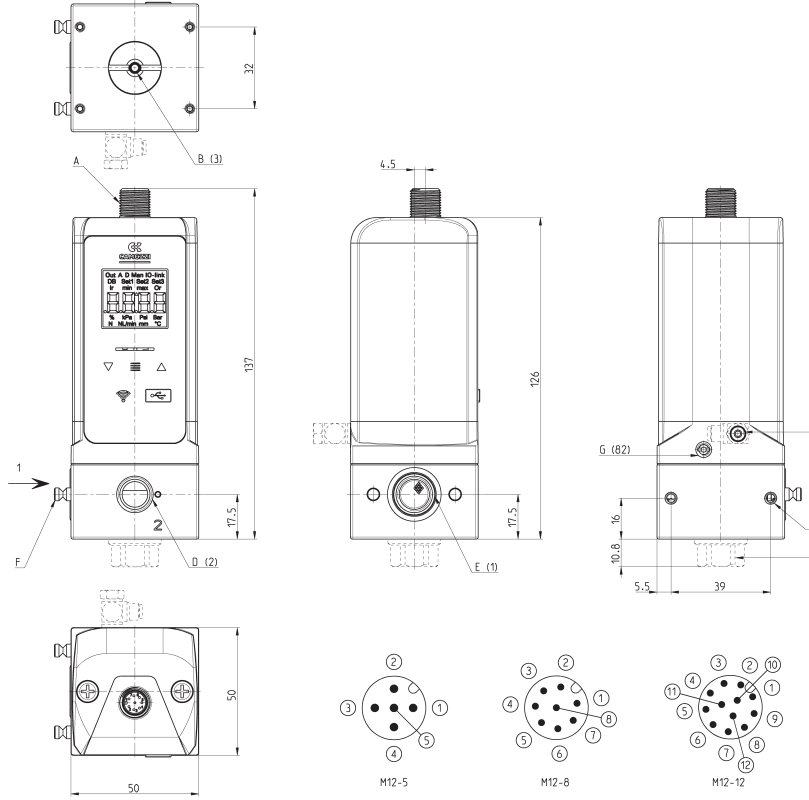

Mod.	A	B (3)	C	D (2)	E (1)	F	G (82)	H
PRE 1	Electrical connection M12	Regulator exhaust G3/8	Fixing holes $\varnothing 4.3$	Outlet G 1/4	Ports G 1/4	Connection pin	Exhaust of pilot solenoids M5	External servo-pilot M5

M12 - 5 (pin male)
for I/O Link version

M12 - 8 (pin male)
for analog version

M12 - 12 (pin male)
for version with external sensor connection

DIMENSIONAL CHARACTERISTICS SERIES PRE SIZE 2 MANIFOLD

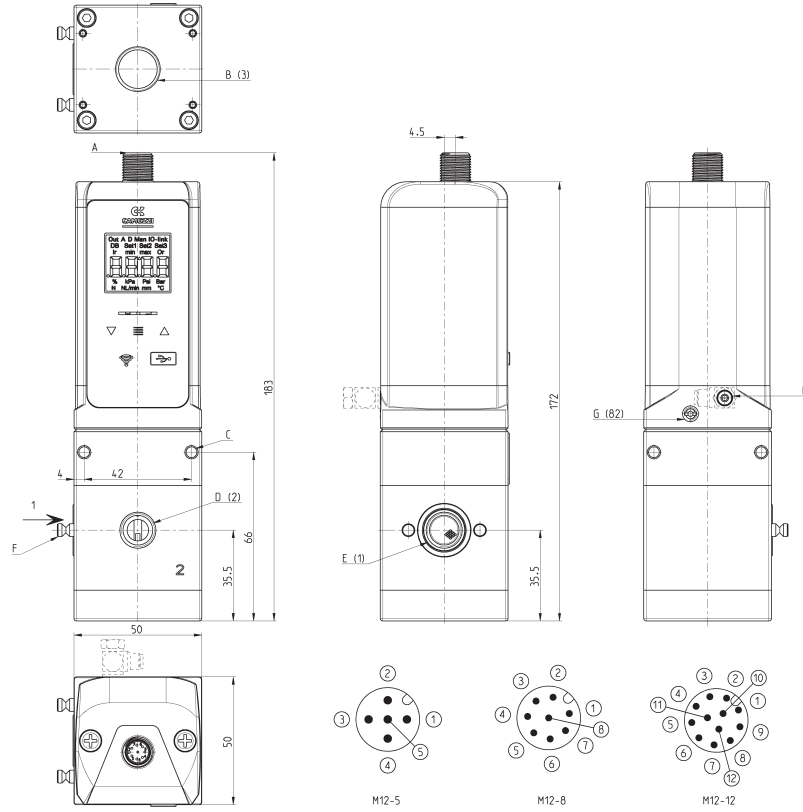

SERIES PRE PROPORTIONAL REGULATORS

Mod.	A	B (3)	C	D (2)	E (1)	F	G (82)	H	I
PRE 2	Electrical Connection M12	Regulator exhaust	Fixing holes M3	Outlet 1/4 (GAS or NPTF)	Ports 1/4 (GAS or NPTF)	Connection pin	Exhaust of pilot solenoids M5	External servo-pilot M5	Valve function (7 - 8) G 1/4

M12 - 5 (pin male)
for I/O Link version

M12 - 8 (pin male)
for analog version

M12 - 12 (pin male)
for version with external sensor connection

FLOW CHARTS SIZE 1 - Standard version (1/4G)

Working pressure 1 bar

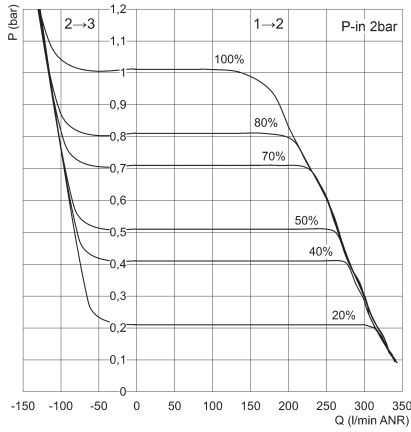

P = Regulated outlet pressure and exhaust pressure
Q = Flow
% = Percentage of the command signal

Working pressure 4 bar

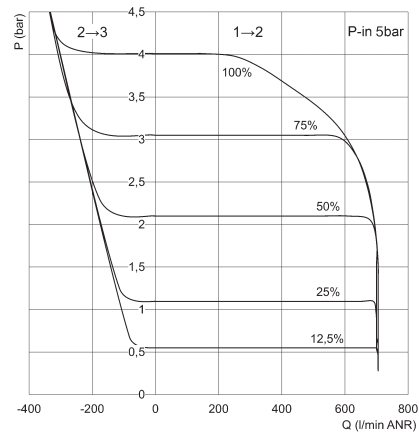

P = Regulated outlet pressure and exhaust pressure
Q = Flow
% = Percentage of the command signal

Working pressure 6 bar

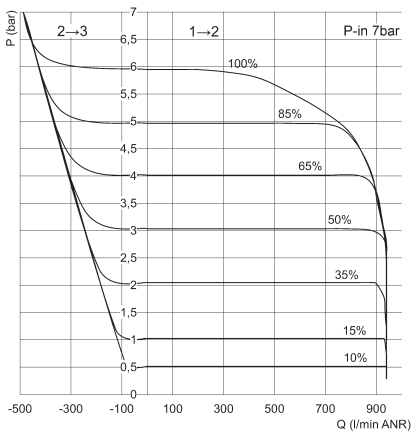

P = Regulated outlet pressure and exhaust pressure
Q = Flow
% = Percentage of the command signal

Working pressure 7 bar

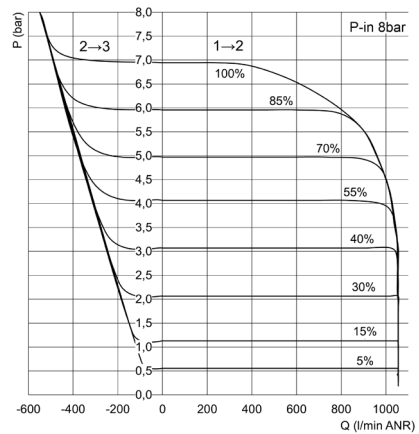

P = Regulated outlet pressure and exhaust pressure
Q = Flow
% = Percentage of the command signal

Working pressure 10.3 bar

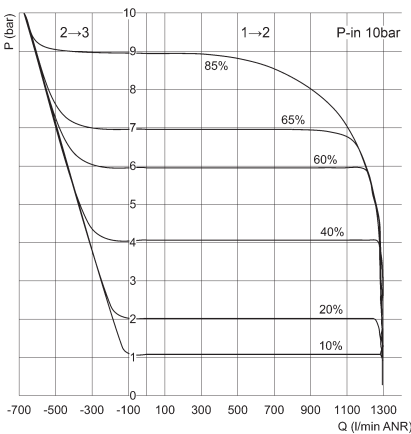

P = Regulated outlet pressure and exhaust pressure
Q = Flow
% = Percentage of the command signal

FLOW CHARTS SIZE 1 - Manifold version (1/4G)

Working pressure 1 bar

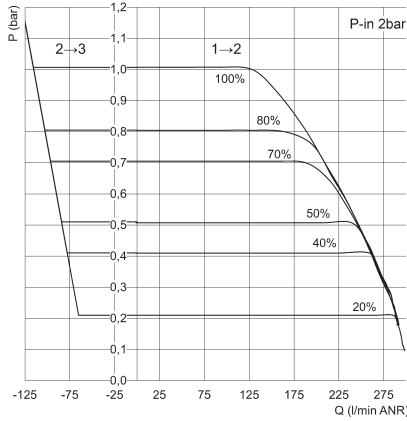

P = Regulated outlet pressure and exhaust pressure
 Q = Flow
 % = Percentage of the command signal

Working pressure 4 bar

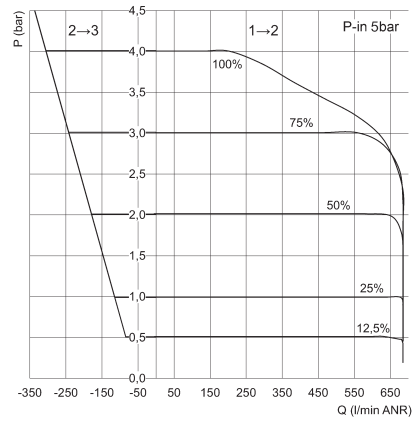

P = Regulated outlet pressure and exhaust pressure
 Q = Flow
 % = Percentage of the command signal

Working pressure 6 bar

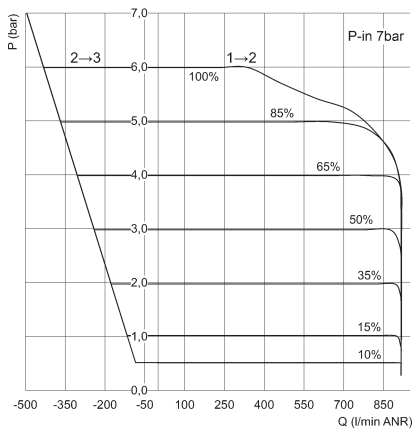

P = Regulated outlet pressure and exhaust pressure
 Q = Flow
 % = Percentage of the command signal

Working pressure 7 bar

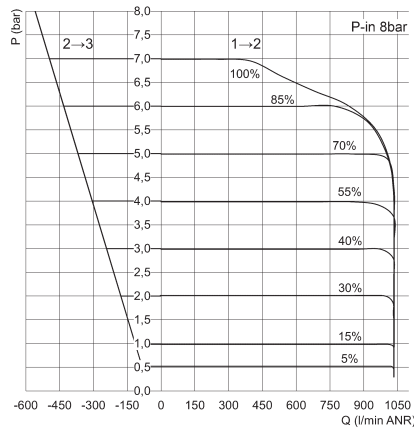

P = Regulated outlet pressure and exhaust pressure
 Q = Flow
 % = Percentage of the command signal

Working pressure 10.3 bar

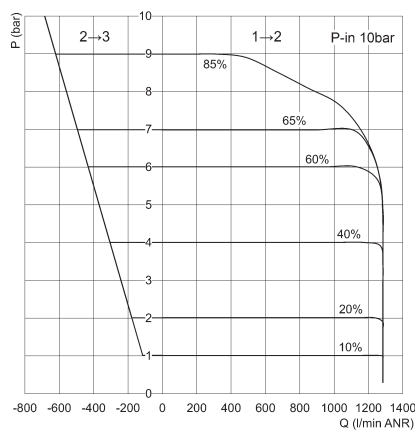

P = Regulated outlet pressure and exhaust pressure
 Q = Flow
 % = Percentage of the command signal

DECAY FACTOR FOR MANIFOLD REGULATORS SIZE 1

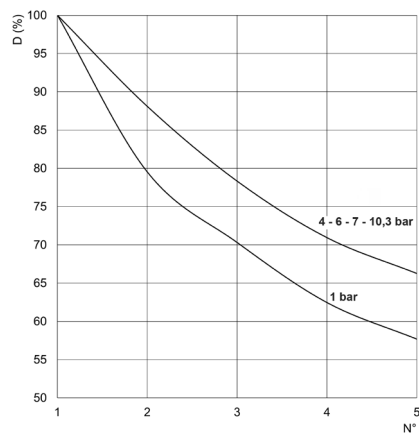

N° = number of regulators in manifold configuration
 D(%) = relative percentage decay of the maximum flow rate
 Note: the air inlet is only from one side, in case it should be on the right and on the left, only consider the positions as from 1 ÷ 3.

FLOW CHARTS SIZE 2 - Standard version (1/4G)

Working pressure 1 bar

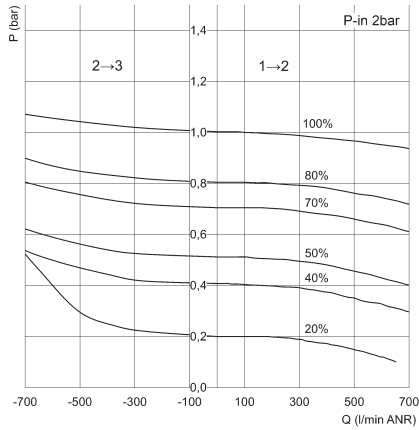

P = Regulated outlet pressure and exhaust pressure
Q = Flow
% = Percentage of the command signal

Working pressure 4 bar

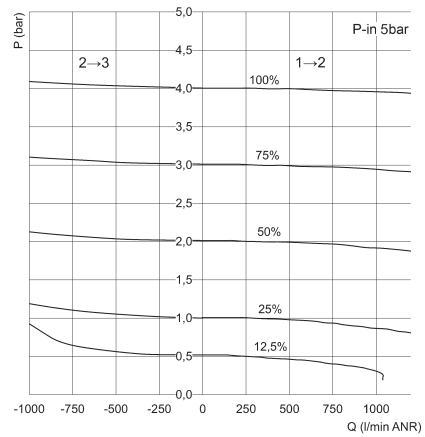

P = Regulated outlet pressure and exhaust pressure
Q = Flow
% = Percentage of the command signal

Working pressure 6 bar

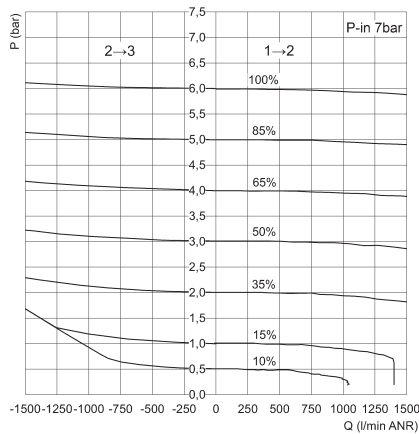

P = Regulated outlet pressure and exhaust pressure
Q = Flow
% = Percentage of the command signal

Working pressure 7 bar

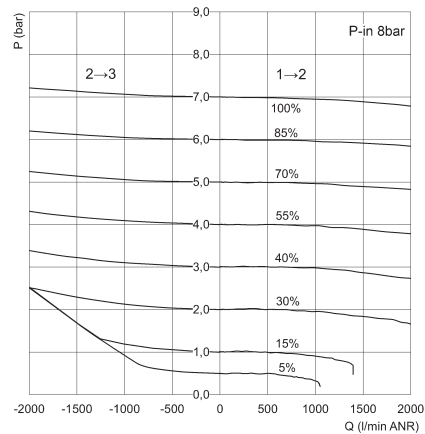

P = Regulated outlet pressure and exhaust pressure
Q = Flow
% = Percentage of the command signal

Working pressure 10.3 bar

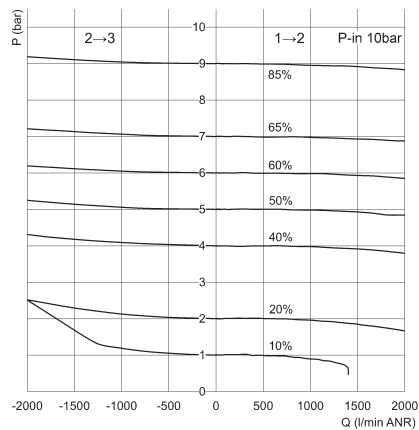

P = Regulated outlet pressure and exhaust pressure
Q = Flow
% = Percentage of the command signal

FLOW CHARTS SIZE 2 - Standard version (3/8G)

Working pressure 1 bar

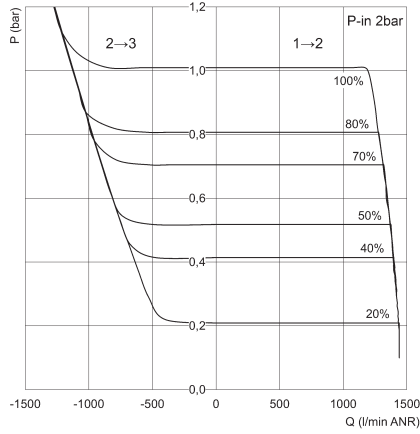

P = Regulated outlet pressure and exhaust pressure
 Q = Flow
 % = Percentage of the command signal

Working pressure 4 bar

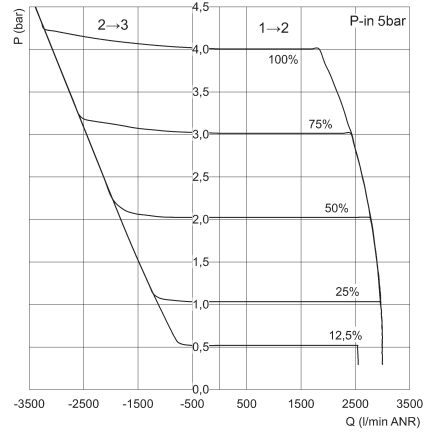

P = Regulated outlet pressure and exhaust pressure
 Q = Flow
 % = Percentage of the command signal

Working pressure 6 bar

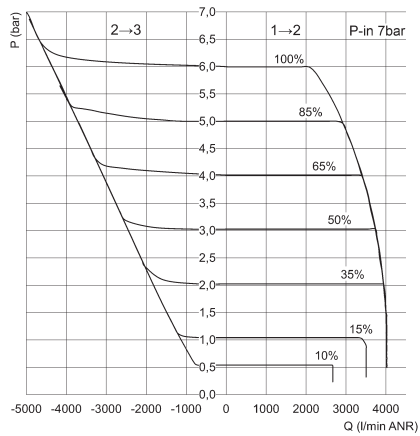

P = Regulated outlet pressure and exhaust pressure
 Q = Flow
 % = Percentage of the command signal

Working pressure 7 bar

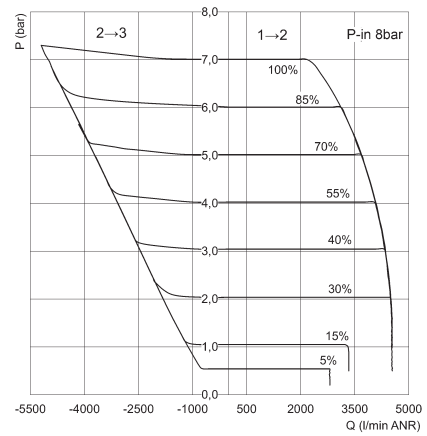

P = Regulated outlet pressure and exhaust pressure
 Q = Flow
 % = Percentage of the command signal

Working pressure 10.3 bar

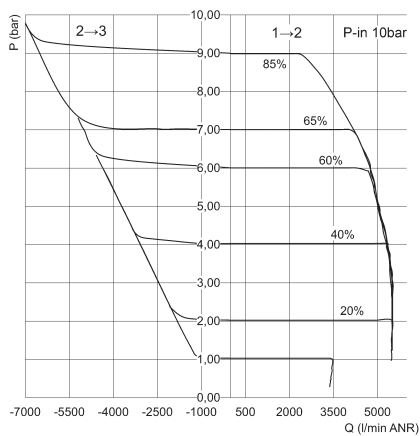

P = Regulated outlet pressure and exhaust pressure
 Q = Flow
 % = Percentage of the command signal

PNEUMATIC SYMBOLS

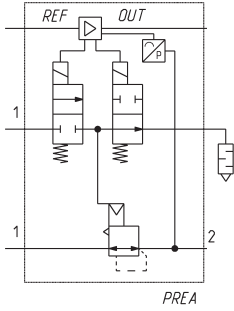

Version with integrated exhaust valve and external servo-pilot supply

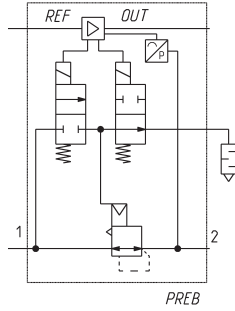

Version with integrated exhaust valve and internal servo-pilot supply

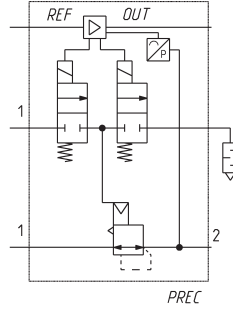

3 ways N.C. version with external servo-pilot supply

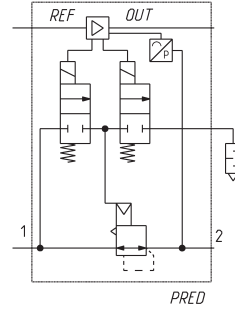

3 ways N.C. version with internal servo-pilot supply

SERIES PRE PROPORTIONAL REGULATORS

SIZE 1 - MATERIALS

R = Proportional regulator
M = Proportional regulator - manifold version

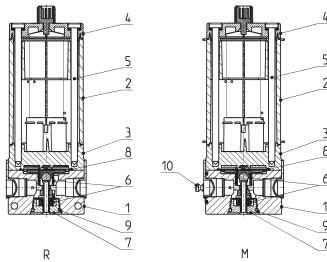

PARTS	MATERIALS, standard version	MATERIALS, oxygen version
1 = body	Anodised aluminium	Anodised aluminium
2 = cover	PA6 CM 30%	PA6 CM 30%
3 = valve body	PARA GF50%	PARA GF50%
4 = cap	PA6 CM 30%	PA6 CM 30%
5 = screws	stainless steel	stainless steel
6 = springs	stainless steel	stainless steel
7 = plug	nickel-plated brass	nickel-plated brass
8 = diaphragm	NBR	FKM
9 = seals and O-Ring	NBR	FKM
10 = pin for manifold version stainless steel only for manifold version stainless steel only for manifold version		

SIZE 2 - MATERIALS

R = Proportional regulator
M = Proportional regulator - manifold version

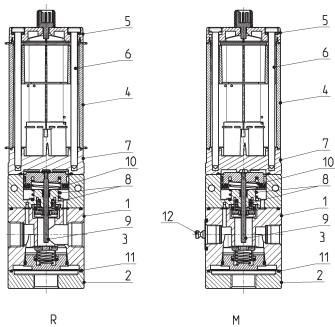

PARTS	MATERIALS, standard version	MATERIALS, oxygen version
1 = body	Anodised aluminium	Anodised aluminium
2 = end cover	Anodised aluminium	Anodised aluminium
3 = plug	brass	brass
4 = cover	PA6 CM 30%	PA6 CM 30%
5 = cap	PA6 CM 30%	PA6 CM 30%
6 = screws	stainless steel	stainless steel
7 = valve body	PARA GF50%	PARA GF50%
8 = springs	stainless steel	stainless steel
9 = piston rod	stainless steel	stainless steel
10 = piston seal	NBR	NBR
11 = seals and O-Ring	NBR	FKM
12 = pin for manifold version stainless steel only for manifold version stainless steel only for manifold version		

MEASURING THE EXHAUST FLOW RATE OF SERIES PRE REGULATOR

Measuring the exhaust flow rate: inlet pressure 9 bar, outlet pressure 4 bar. With the pressure regulator opposite the PRE (C), connected as shown in the diagram, the pressure rises progressively from a minimum value of 4 bar and with the flowmeter (B) the exhaust flow rate is measured from the exhaust port.

- A = Ball valve
- B = Flowmeter
- C = Back pressure regulator

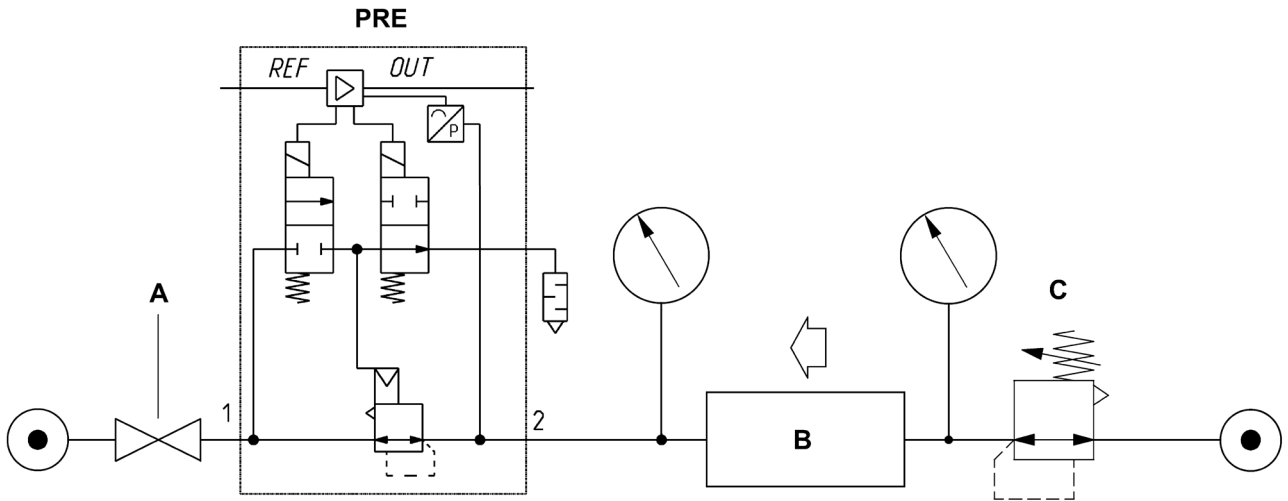

PNEUMATIC DIAGRAM FOR INSTALLATION

PRE version with integrated exhaust valve. We suggest to make a pneumatic diagram in order to create a pneumatic circuit that allows to discharge the regulated pressure in absence of power supply.

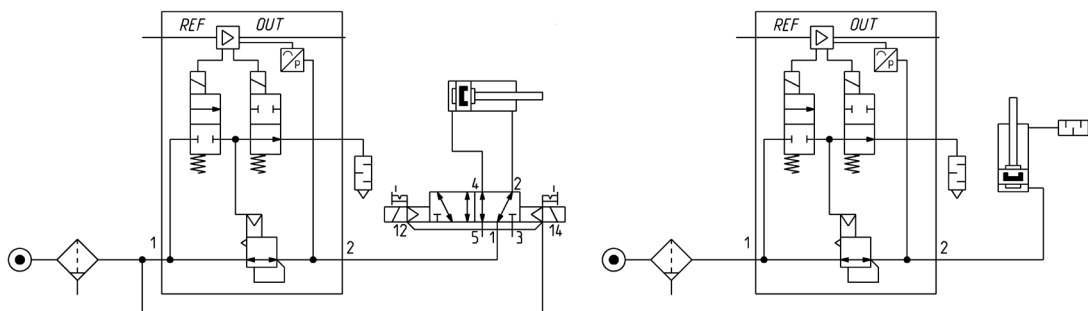

Cable with M12 8 pin straight connector, female

For power supply, analog command signal and PreSet

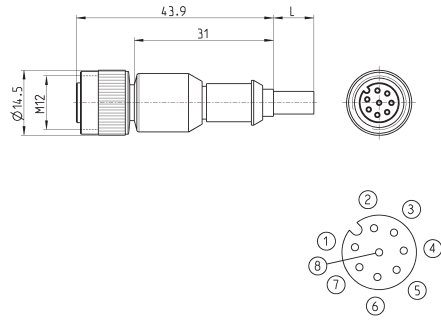

Mod.	Cable length (m)	
CS-LF08HB-H200	2	Unshielded
CS-LF08HB-H500	5	Unshielded
CS-LF08HC-G200	2	Shielded
CS-LF08HC-G500	5	Shielded

Cable with M12 8 pin connector, 90°, female

For power supply, analog command signal and PreSet

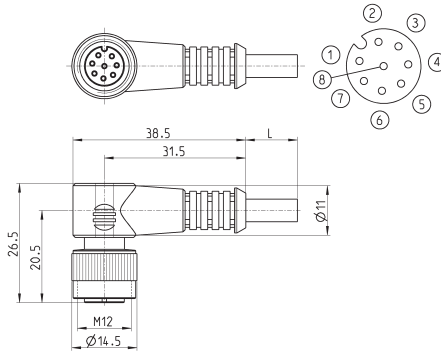

Mod.	Cable length (m)	
CS-LR08HB-H200	2	Unshielded
CS-LR08HB-H500	5	Unshielded
CS-LR08HC-G200	2	Shielded
CS-LR08HC-G500	5	Shielded

Cable with M12 5 pin connector, 90°, female, not shielded

For power supply and IO-Link command signal

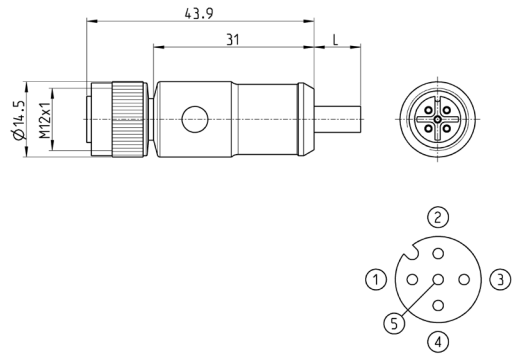

Mod.	Cable length (m)
CS-LF05HB-D200	2
CS-LF05HB-D500	5

Cable with M12 5 pin connector straight, female, not shielded

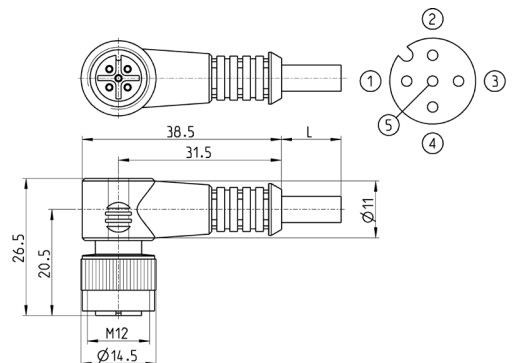

Mod.	Cable length (m)
CS-LR05HB-D200	2
CS-LR05HB-D500	5

Cable with M12, 12 pin connector, straight, female, not shielded

For power supply and analog command signal with external sensor

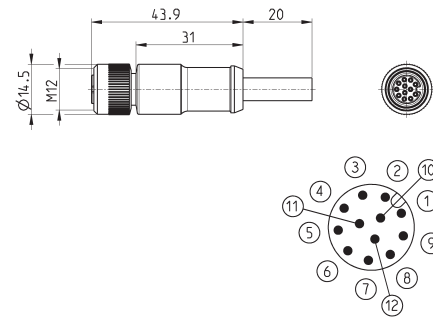

Mod.	Cable length (m)
CS-LF12HC-D200	2
CS-LF12HC-D500	5

Cable with M12 12 pin connector, 90°, female, not shielded

For electric supply and commands

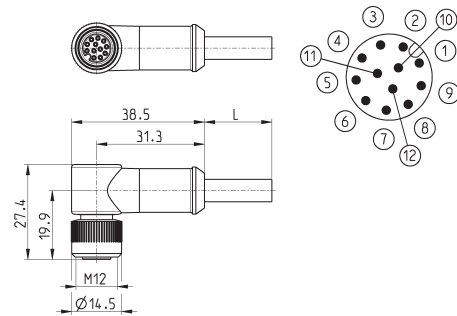

Mod.	Cable length (m)
CS-LR12HC-D200	2
CS-LR12HC-D500	5

Electrical tee box Mod. CS-AA08EC

To connect the external transducer, power supply and command signal

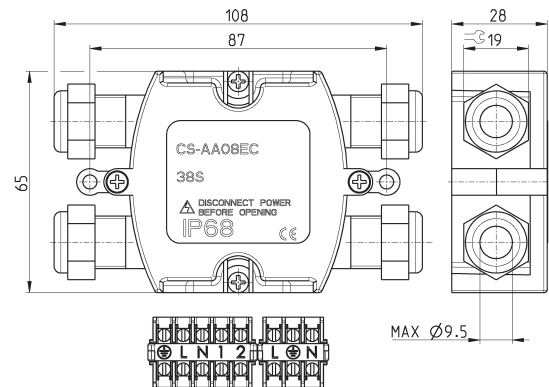

CS-AA08EC

Mounting brackets for DIN-rail Mod. PCF-EN531

DIN EN 50022 (7,5mm x 35mm - width 1)



Supplied with:
2x mounting brackets
2x screws M4x6 UNI 5931
2x nuts

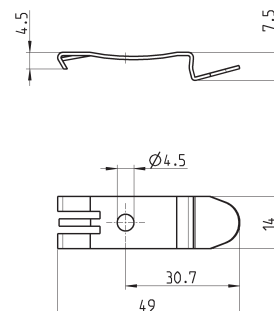

Mod.
PCF-EN531

Rear bracket Mod. PRE-ST



The kit includes
1x zinc-plated bracket
2x M4x55 white zinc-plated screws

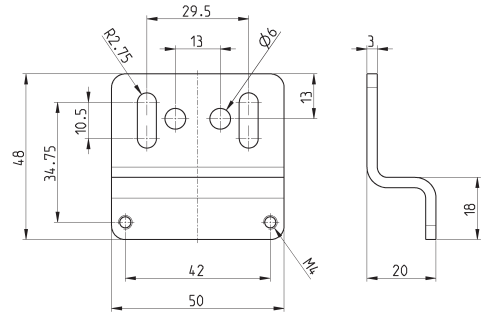

PRE-ST

Fixing kit for manifold version: PRE-M-PIN-1-2



The kit includes:
2x shaped steel pins
4x steel grub screws
1x O-Ring

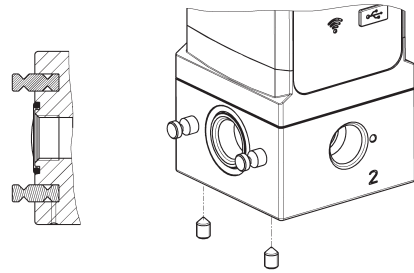

PRE-M-PIN-1-2

Fixing kit for Series MD: PRE



The kit includes:
1x bushing
1x O-Ring
2x special $\varnothing 4.5 \times 34$ white zinc-plated screws

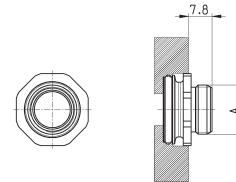

DIMENSIONS	
Mod.	A
PRE-1/4-C	G1/4
PRE-3/8-C	G3/8

Fittings for external pilot supply

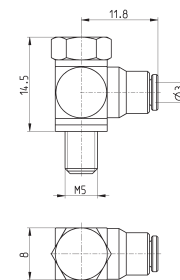

6625 3-M5

Series N filter-regulators

Ports G1/8, G1/4



» Available with: transparent PA12 bowl or nickel-plated brass bowl for the small version (N1)

The version with metal bowl is particularly suitable for applications subject to impacts or in the presence of aggressive agents that could damage the PA12 bowl.

Series N filter-regulator is available with G1/4 and G1/8 ports. Its design incorporates a self relieving diaphragm. The transparent filter bowl allows an easy monitoring of the condensate level. The semi-automatic manual drain makes both the manual and automatic condensate exhaust easier when there is no pressure.

GENERAL DATA

Construction	HDPE and coalescing filtering element
Materials	brass body and poppet stainless steel spring NBR O-ring HDPE filtering element transparent PA12 or nickel-plated bowl others: PA
Ports	G1/8 - G1/4
Max. condensate capacity	11 cm ³ (bowl size = 1) 28 cm ³ (bowl size = 2)
Weight	0.370 Kg
Pressure gauge ports	G1/8
Mounting	vertical, in-line
Operating temperature	-5°C ÷ 50°C a 10 bar (with the dew point of the fluid lower than 2°C at the min. working temperature)
Quality of delivered air according to ISO 8573-1 2010	Class 7.8.4 with 25 µm filtering element Class 6.8.4 with 5 µm filtering element
Draining of condensate	see the coding example
Inlet pressure	with standard drain and protected depressurisation 0.3 ÷ 16 bar
Outlet pressure	with depressurisation drain 0.3 ÷ 10 bar
Nominal flow	see FLOW DIAGRAMS on the following pages
Secondary pressure relieving	with relieving (standard) without relieving
Fluid	compressed air

CODING EXAMPLE

N	2	04	-	D	0	0	-	4	-
----------	----------	-----------	----------	----------	----------	----------	----------	----------	----------

N	SERIES
2	SIZE: 1 = small bowl (11 cm ³) 2 = normal bowl (28 cm ³)
04	PORTS: 08 = G1/8 04 = G1/4
D	D = FILTER-REGULATOR
0	FILTERING ELEMENT: 0 = 25µm (standard) 1 = 5µm
0	DRAINING OF CONDENSATE (further details in the dedicated section) AND DESIGN TYPE: 0 = semi-automatic manual drain with self-relieving 1 = semi-automatic manual drain without relieving 4 = depressurisation with self-relieving (with normal bowl only) 5 = protected depressurisation with self-relieving (with normal bowl only) 8 = no drain (direct port 1/8), with self-relieving
4	OPERATING PRESSURE: = 0.5 ÷ 10 bar (standard) 2 = 0.5 ÷ 2 bar 4 = 0.5 ÷ 4 bar 7 = 0.5 ÷ 7 bar
	BOWL MATERIAL: = transparent PA12 (standard) TM = nickel-plated brass (only in the small size with semi-automatic manual drain or without drain)

SERIES N FILTER-REGULATORS

Series N filter-regulators



FR01 = filter-regulator with relieving and manual drain
FR02 = FR with relieving and without drain
FR11 = FR with manual drain and without relieving

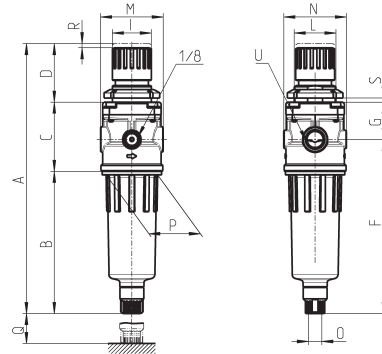
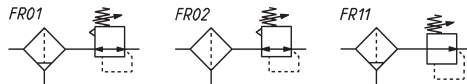

Mod.	A	B	C	D	F	G	I	L	M	N	O	P	Q	R	S	U
N108-D00	167	78	50	39	101	27	28	M30x1,5	45	45	G1/8	38	40	3	0 ÷ 6	G1/8
N104-D00	167	78	50	39	101	27	28	M30x1,5	45	45	G1/8	38	40	3	0 ÷ 6	G1/4
N208-D00	191	102	50	39	125	27	28	M30x1,5	45	45	G1/8	38	40	3	0 ÷ 6	G1/8
N204-D00	191	102	50	39	125	27	28	M30x1,5	45	45	G1/8	38	40	3	0 ÷ 6	G1/4
N104-D19-OX1	147	59	50	39	82	27	28	M30x1,5	45	45		38	40	3	0 ÷ 6	G1/4
N108-D19-OX1	147	59	50	39	82	27	28	M30x1,5	45	45		38	40	3	0 ÷ 6	G1/8

FLOW DIAGRAMS

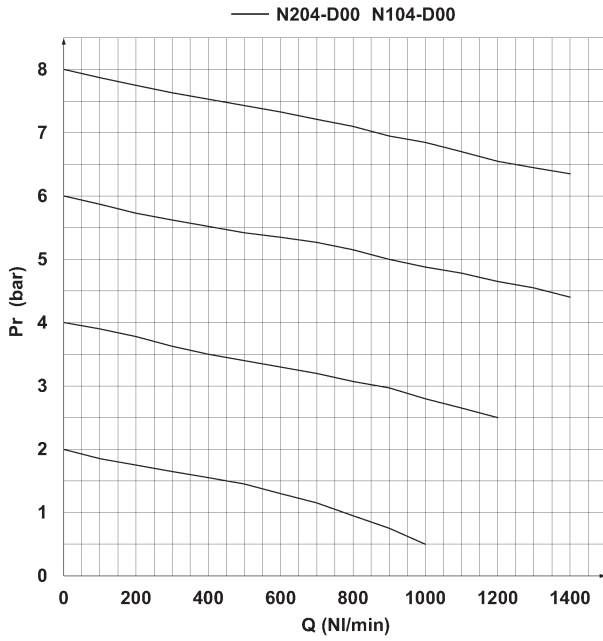

Flow diagrams for models: N204-D00 - N104-D00

Pa = Inlet pressure (bar)
 Pr = Regulated pressure (bar)
 Qn = Flow (NL/min)

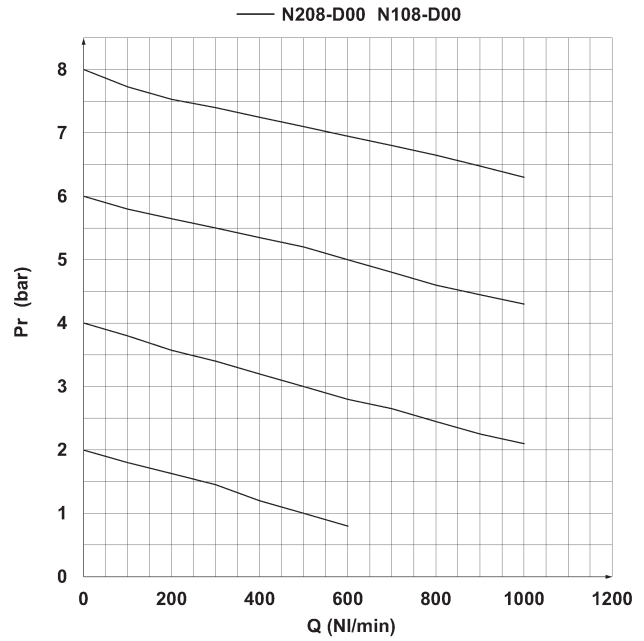

Flow diagrams for models: N208-D00 - N108-D00

Pa = Inlet pressure (bar)
 Pr = Regulated pressure (bar)
 Qn = Flow (NL/min)

Series TC pressure microregulators

For applications with oxygen, without relieving
Ports: cartridge construction, G1/8 and 1/8 NPTF

SERIES TC MICROREGULATORS



- » Compact design
- » High performance
- » Easy to install
- » Materials suitable with several gases

The Series TC pressure regulator has been designed to be used for all the applications and equipment where it is needed to insert the single component in customized integrated pneumatic circuits (manifolds) or collectors.

The cartridge design and the compact size allow the regulator to be plugged in a proper seat, making the installation easier and reducing the assembly time. To produce the new TC regulator, materials have been analyzed and chosen on the basis of their suitability with the contact medium. The body in PPS and the seals in FKM ensure thus full compatibility with a wide range of gaseous fluids.

GENERAL DATA

Construction	compact with pre-formed diaphragm
Materials	see the TABLE OF MATERIALS on the following page
Ports	cartridge construction in manifold - G1/8 or 1/8NPTF (aluminium body version only)
Mounting	in-line or cartridge (any position)
Operating temperature	-5°C ÷ 50°C
Inlet pressure	0 ÷ 10 bar
Outlet pressure	0.03 ÷ 0.5 bar 0.1 ÷ 2 bar 0.15 ÷ 3 bar 0.2 ÷ 4 bar
Overpressure exhaust	without relieving
Nominal flow	see FLOW DIAGRAMS on the following pages
Medium	air, inert and medical gases, OXYGEN
Repeatability	±0.2% FS

CODING EXAMPLE

TC	1	-	R	3	1	-	C	-	V	-	OX2
-----------	----------	----------	----------	----------	----------	----------	----------	----------	----------	----------	------------

TC	SERIES
1	SIZE
R	REGULATOR
3	WORKING PRESSURE: 1 = 0.03 ÷ 0.5 bar 2 = 0.1 ÷ 2 bar 3 = 0.15 ÷ 3 bar 4 = 0.2 ÷ 4 bar
1	TYPE OF CONSTRUCTION: 1 = without relieving
C	PORTS: C = Cartridge 1/8 = G1/8 1/8TF = 1/8NPTF
V	SEALS MATERIAL: V = FKM
OX2	VERSIONS: OX1 = for oxygen (non-volatile residue lower than 550 mg/m ²) OX2 = for oxygen (non-volatile residue lower than 35 mg/m ²)

SERIES TC MICROREGULATORS

Series TC pressure microregulators - materials

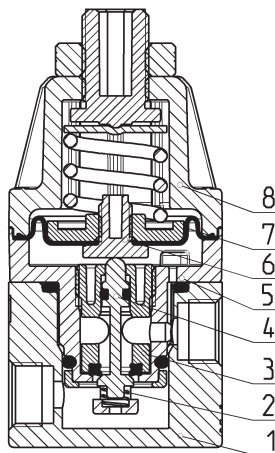

PARTS	MATERIALS
1. Base body	Anodized aluminium
2. Lower spring	Stainless steel
3. Insert	PPS
4. Poppet	Stainless steel
5. Body	PPS
6. Valve guide	PPS
7. Diaphragm	FKM
8. Bell	Polyamide
Seals	FKM

FLOW DIAGRAMS - 0.5 and 2 bar working pressure

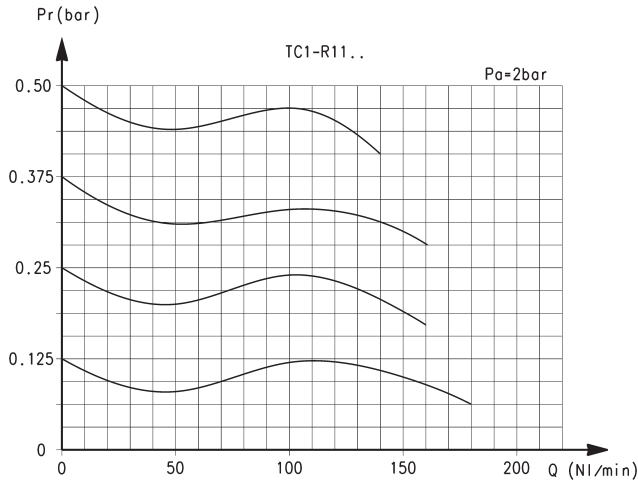

Pr = Regulated pressure (bar)
Q = Flow (NI/min)

Pa = Inlet pressure (bar)

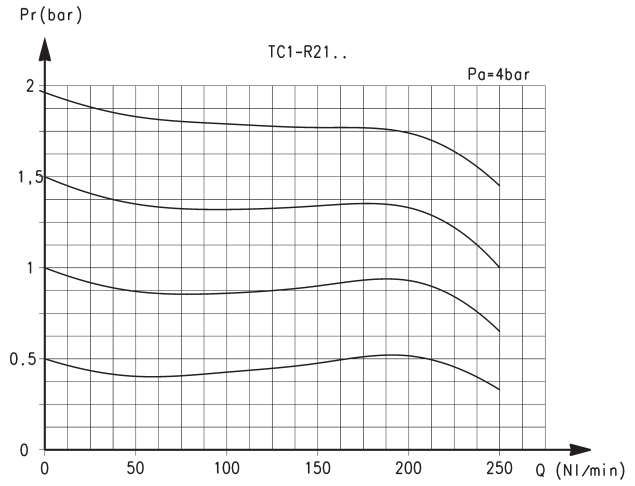

Pr = Regulated pressure (bar)
Q = Flow (NI/min)

Pa = Inlet pressure (bar)

FLOW DIAGRAMS - 3 and 4 bar working pressure

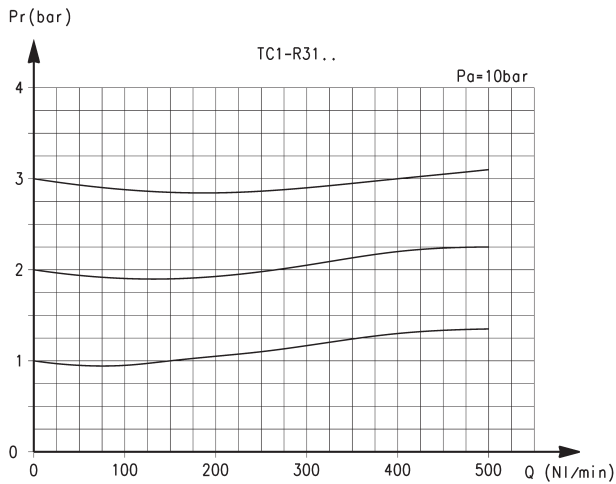

Pr = Regulated pressure (bar)
Q = Flow (NI/min)

Pa = Inlet pressure (bar)

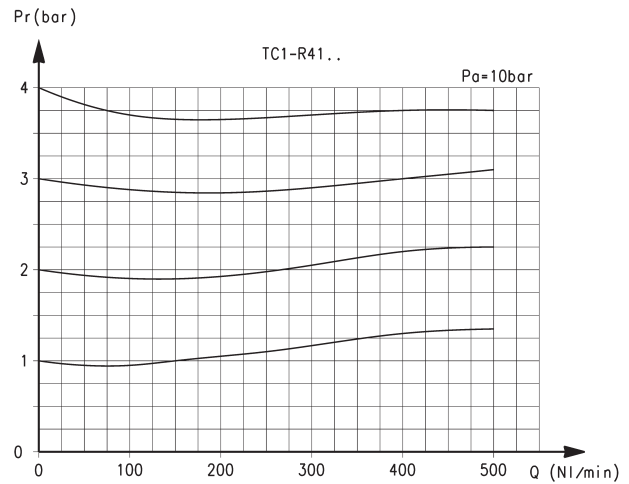

Pr = Regulated pressure (bar)
Q = Flow (NI/min)

Pa = Inlet pressure (bar)

Series TC cartridge pressure microregulators

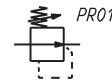
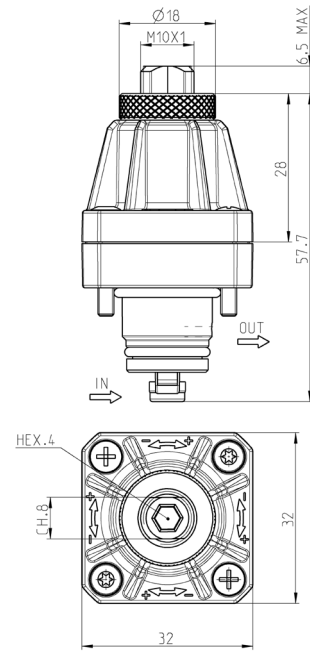

PR01 = regulator without relieving

Mod.

TC1-R11-C-V-OX1

TC1-R11-C-V-OX2

TC1-R21-C-V-OX1

TC1-R21-C-V-OX2

TC1-R31-C-V-OX1

TC1-R31-C-V-OX2

TC1-R41-C-V-OX1

TC1-R41-C-V-OX2

Series TC pressure microregulators with aluminium body



* to choose the type of thread (G1/8 or 1/8 NPTF)
see the Coding example

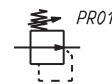
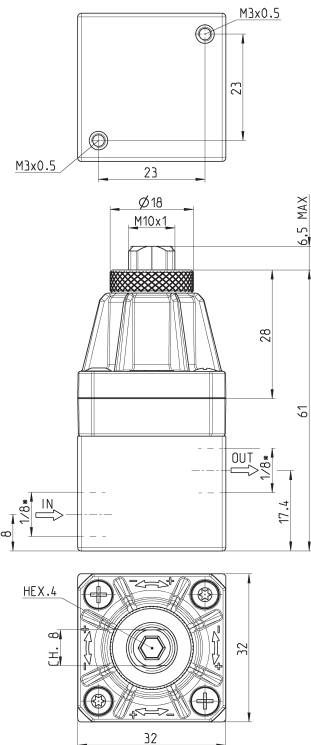

PR01 = regulator without relieving

Mod.

TC1-R11-^o-V-OX1

TC1-R11-^o-V-OX2

TC1-R21-^o-V-OX1

TC1-R21-^o-V-OX2

TC1-R31-^o-V-OX1

TC1-R31-^o-V-OX2

TC1-R41-^o-V-OX1

TC1-R41-^o-V-OX2

Seat dimensions for cartridge version

SERIES TC MICROREGULATORS

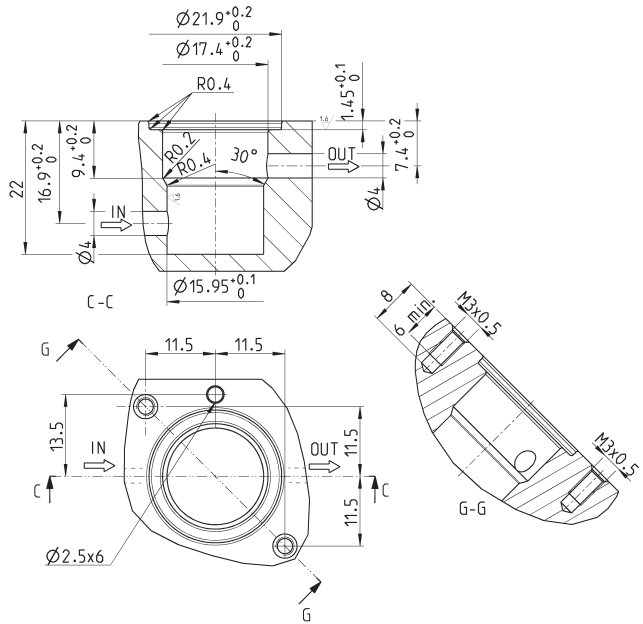

Series PR precision regulators with manual override

Size 1 ports: G1/4

Size 2 ports: G1/4, G3/8



- » High precision adjustment
- » Multi-diaphragm construction to reach the highest stability
- » Adjustment lock
- » Compact dimensions
- » Removable adjustment knob

The Series PR precision pressure regulators are ideal for applications that require a precise and stable air pressure control. The operating principle using multiple diaphragms allows the Series PR to react to even the smallest pressure variations that may occur during use.

GENERAL DATA

Construction	compact, multi-diaphragm type
Materials	see the following page
Ports	Size 1: G1/4 Size 2: G1/4, G3/8
Mounting	vertical in-line, wall or panel mounting (in any position)
Working temperature	0°C ÷ 50°C
Inlet pressure	0.1 ÷ 12 bar
Outlet pressure	0.05 ÷ 2 bar 0.05 ÷ 4 bar 0.05 ÷ 7 bar 0.05 ÷ 10 bar
Overpressure exhaust	with relieving (standard)
Nominal flow	see FLOW DIAGRAMS on the following pages
Media	filtered and not lubricated compressed air according to DIN ISO 8573-1 Classes 1-3-2
Hysteresis	20mbar
Repeatability	±0.2% FS
Bleed air consumption	≤ 5 l/min

CODING EXAMPLE

PR	1	04	-	M	07
PR	SERIES				
1	SIZE: 1 = size 1 2 = size 2				
04	PORTS: 04 = G1/4 38 = G3/8 (size 2 only)				
M	TYPE OF ADJUSTMENT: M = manual				
07	OPERATING PRESSURE (1 bar = 14,5 psi): 02 = 0.05 ÷ 2 bar 04 = 0.05 ÷ 4 bar 07 = 0.05 ÷ 7 bar 00 = 0.05 ÷ 10 bar				

SERIES PR PRECISION REGULATORS

Series PR precision regulators - materials

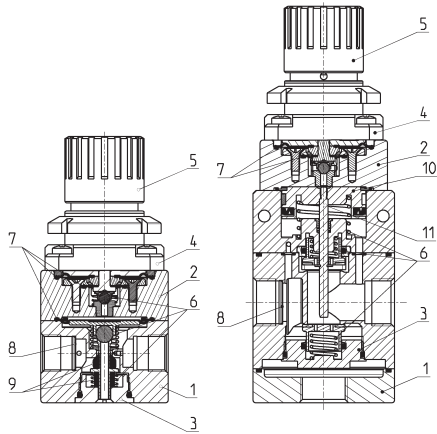

PARTS	MATERIALS
1 = Body	Anodized aluminium
2 = Intermediate body	Aluminium
3 = Valve holder plug	Brass
4 = Bell	Polyamide
5 = Regulator knob	Polyamide
6 = Springs	Stainless steel
7 = Diaphragms	NBR
8 = Filters	Stainless steel
9 = Seals	NBR
10 = Piston	Aluminium
11 = Rod	Stainless steel
O-ring	NBR

Series PR precision regulators - size 1



* to complete the code, add the OPERATING PRESSURE (see the CODING EXAMPLE)

PR02 = Regulator with relieving

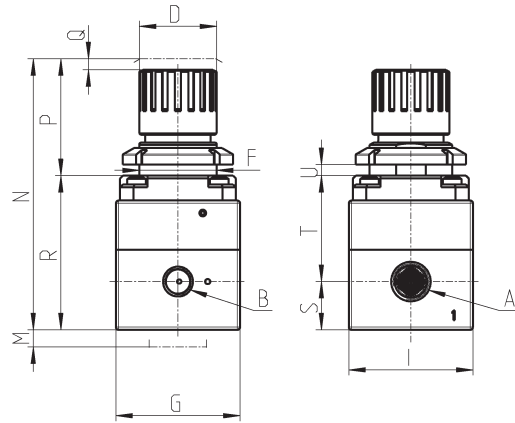
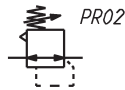

DIMENSIONS																
Mod.	A	B	D	F	G	I	M	N	P	Q	R	S	T	U	Weight (Kg)	
PR104-M*	G1/4	G1/8	28	30	45	45	25	96	40	2	56	17.5	38.5	0-6	0.35	

Series PR precision regulators - size 2



* to complete the code, add the OPERATING PRESSURE (see the CODING EXAMPLE)

PR02 = Regulator with relieving

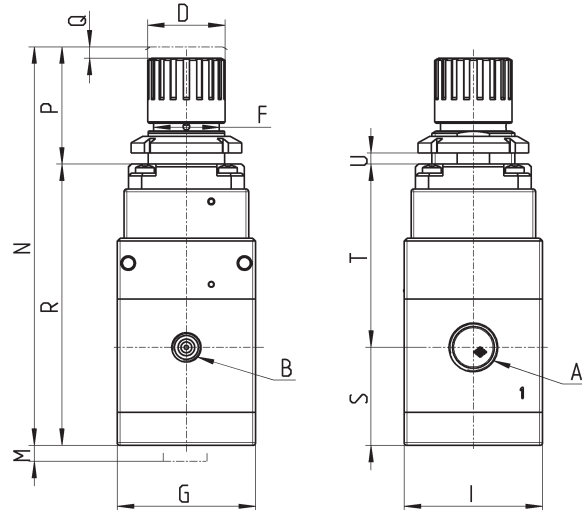

DIMENSIONS																
Mod.	A	B	D	F	G	I	M	N	P	Q	R	S	T	U	Weight (Kg)	
PR204-M*	G1/4	G1/8	28	30	50	50	25	140	40	2	101.8	35.5	66.3	0-6	0.645	
PR238-M*	G3/8	G1/8	28	30	50	50	25	140	40	2	101.8	35.5	66.3	0-6	0.645	

FLOW DIAGRAMS Mod. PR104-M00

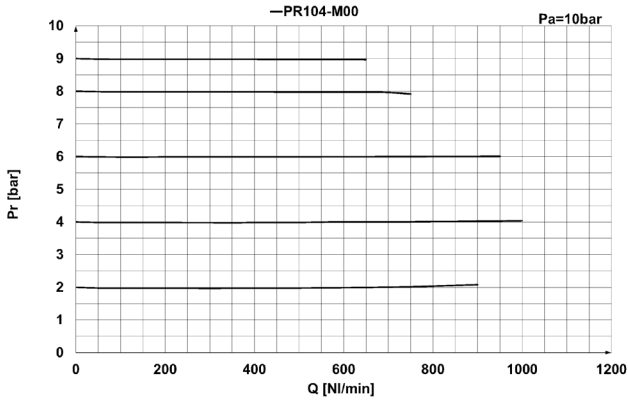

Pr = Regulated pressure (bar)
Q = Flow (NL/min)
Pa = Inlet pressure (bar)

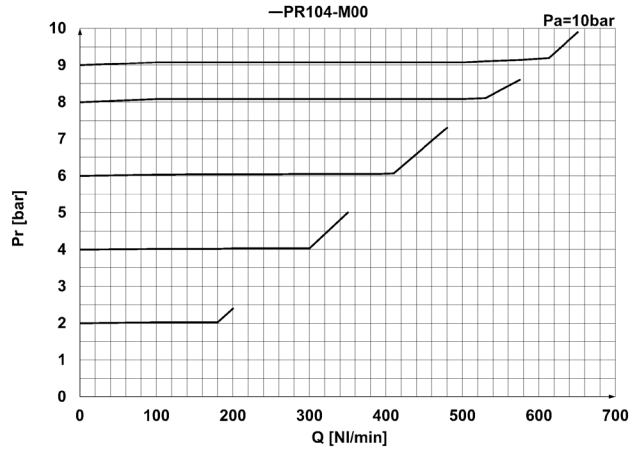

EXHAUST FLOW
Pr = Regulated pressure (bar)
Q = Flow (NL/min)
Pa = Inlet pressure (bar)

FLOW DIAGRAMS Mod. PR104-M07

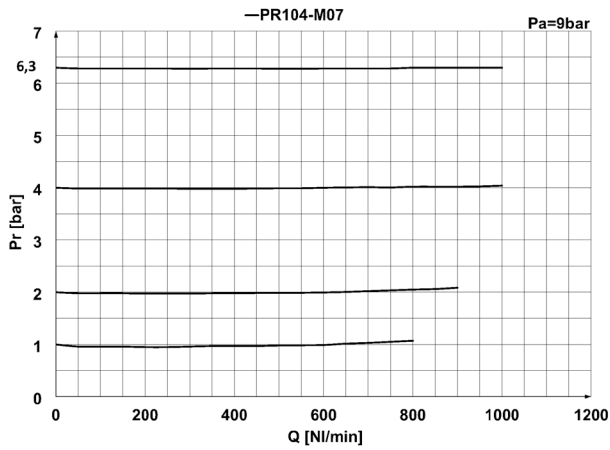

Pr = Regulated pressure (bar)
Q = Flow (NL/min)
Pa = Inlet pressure (bar)

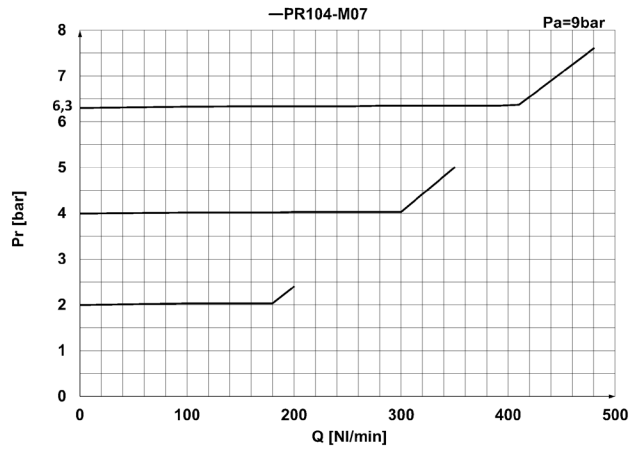

EXHAUST FLOW
Pr = Regulated pressure (bar)
Q = Flow (NL/min)
Pa = Inlet pressure (bar)

FLOW DIAGRAMS Mod. PR104-M04

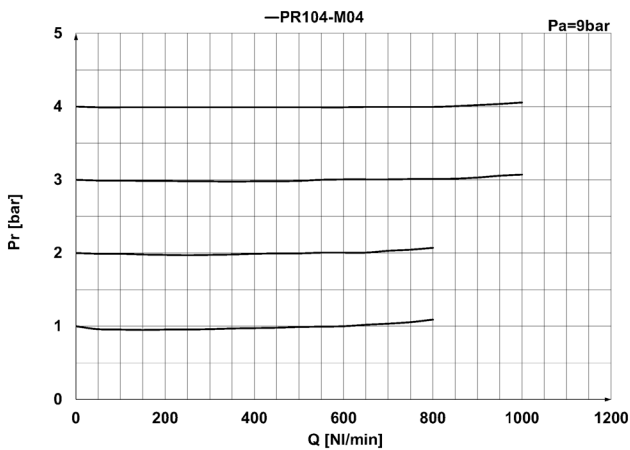

Pr = Regulated pressure (bar)
Q = Flow (NL/min)
Pa = Inlet pressure (bar)

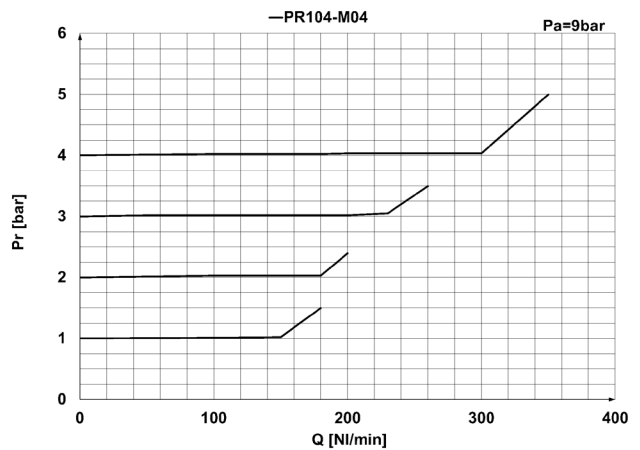

EXHAUST FLOW
Pr = Regulated pressure (bar)
Q = Flow (NL/min)
Pa = Inlet pressure (bar)

FLOW DIAGRAMS Mod. PR104-M02

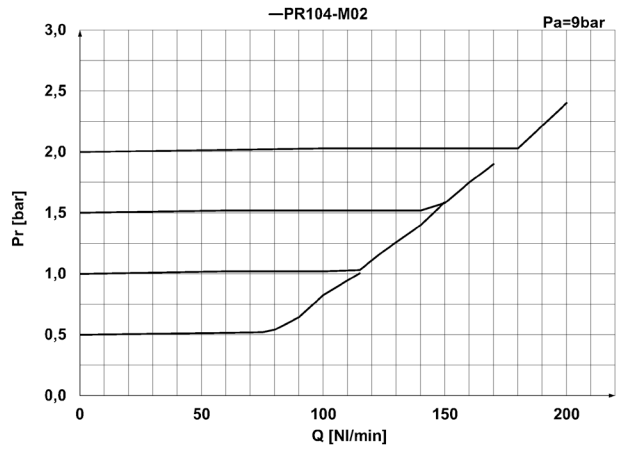
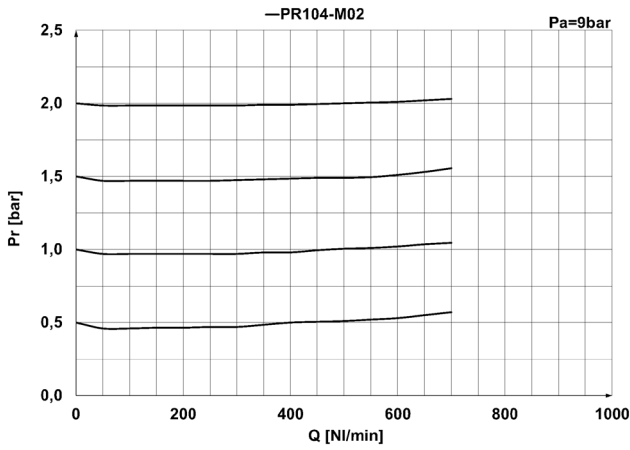

Pr = Regulated pressure (bar)
 Q = Flow (NL/min)
 Pa = Inlet pressure (bar)

EXHAUST FLOW
 Pr = Regulated pressure (bar)
 Q = Flow (NL/min)
 Pa = Inlet pressure (bar)

FLOW DIAGRAMS Mod. PR204-M00

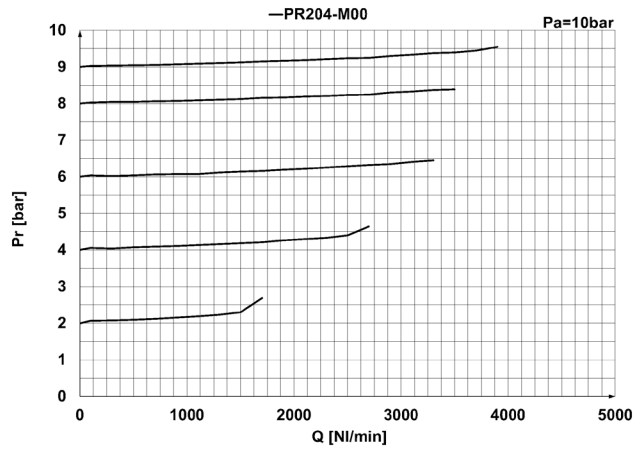
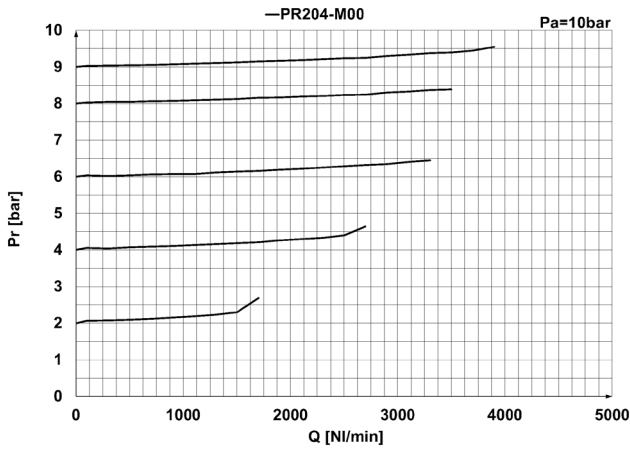

Pr = Regulated pressure (bar)
 Q = Flow (NL/min)
 Pa = Inlet pressure (bar)

EXHAUST FLOW
 Pr = Regulated pressure (bar)
 Q = Flow (NL/min)
 Pa = Inlet pressure (bar)

FLOW DIAGRAMS Mod. PR204-M07

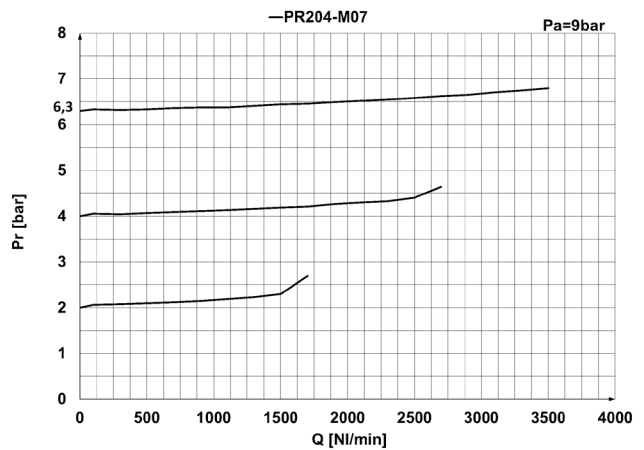
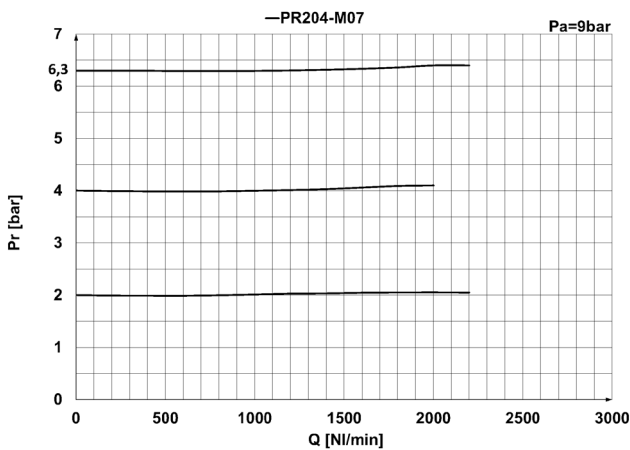

Pr = Regulated pressure (bar)
 Q = Flow (NL/min)
 Pa = Inlet pressure (bar)

EXHAUST FLOW
 Pr = Regulated pressure (bar)
 Q = Flow (NL/min)
 Pa = Inlet pressure (bar)

FLOW DIAGRAMS Mod. PR204-M04

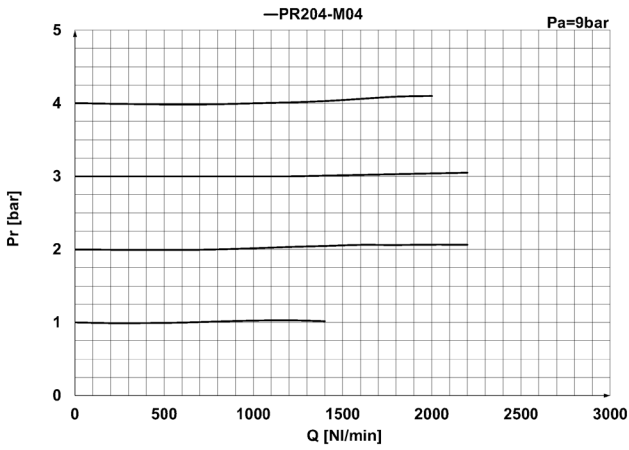

Pr = Regulated pressure (bar)
Q = Flow (NL/min)
Pa = Inlet pressure (bar)

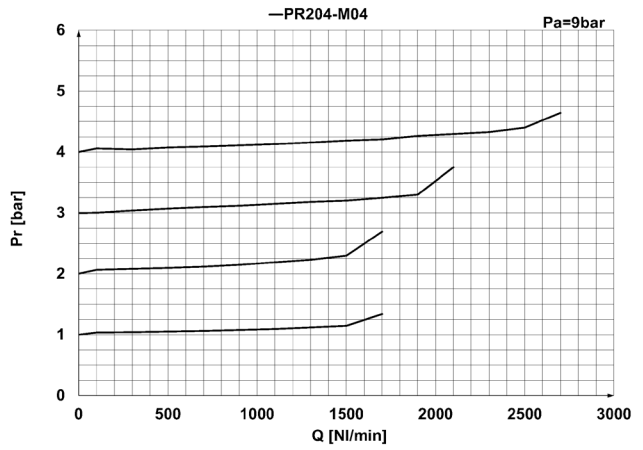

EXHAUST FLOW
Pr = Regulated pressure (bar)
Q = Flow (NL/min)
Pa = Inlet pressure (bar)

FLOW DIAGRAMS Mod. PR204-M02

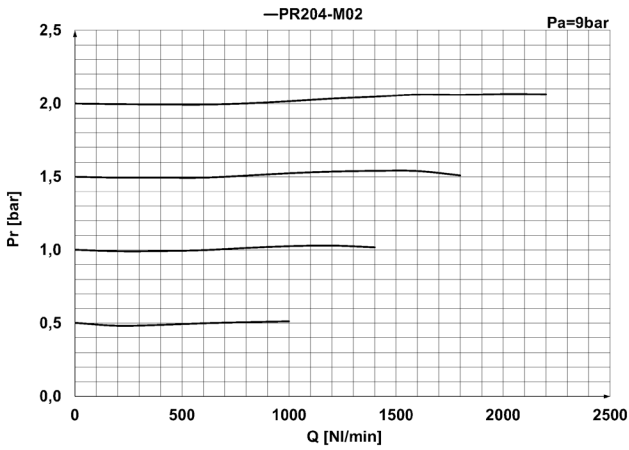

Pr = Regulated pressure (bar)
Q = Flow (NL/min)
Pa = Inlet pressure (bar)

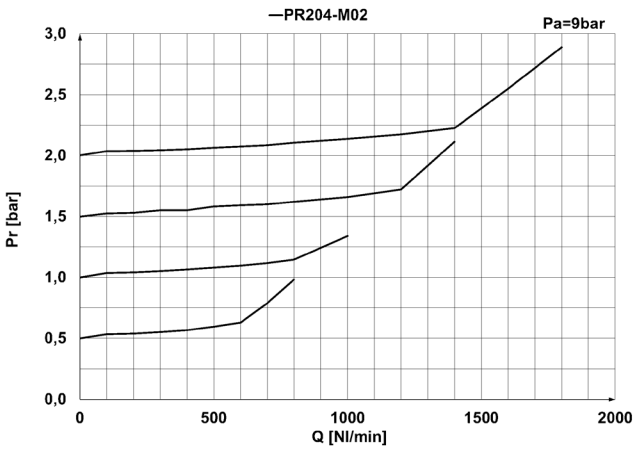

EXHAUST FLOW
Pr = Regulated pressure (bar)
Q = Flow (NL/min)
Pa = Inlet pressure (bar)

FLOW DIAGRAMS Mod. PR238-M00

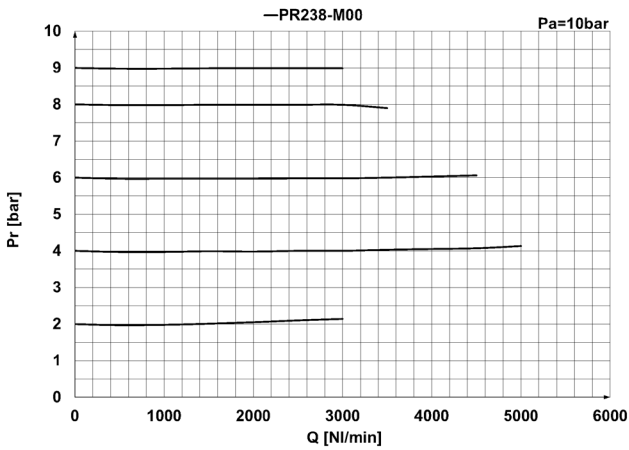

Pr = Regulated pressure (bar)
Q = Flow (NL/min)
Pa = Inlet pressure (bar)

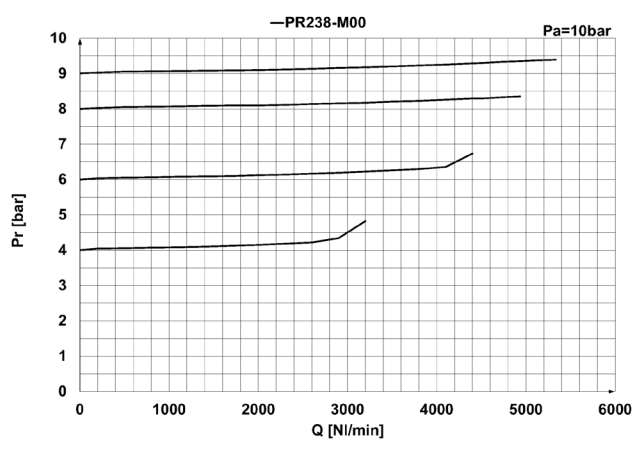

EXHAUST FLOW
Pr = Regulated pressure (bar)
Q = Flow (NL/min)
Pa = Inlet pressure (bar)

FLOW DIAGRAMS Mod. PR238-M07

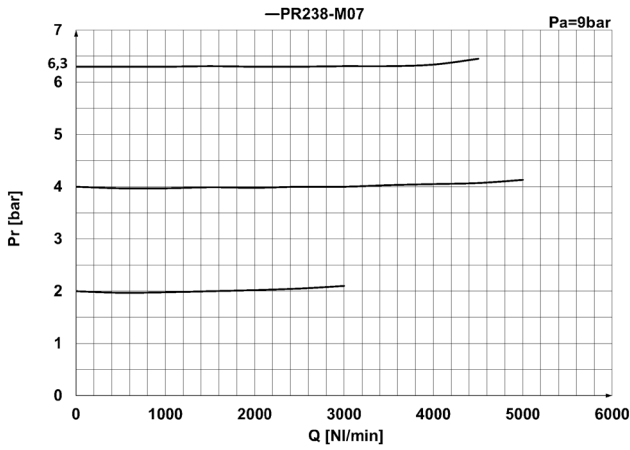

Pr = Regulated pressure (bar)
 Q = Flow (NL/min)
 Pa = Inlet pressure (bar)

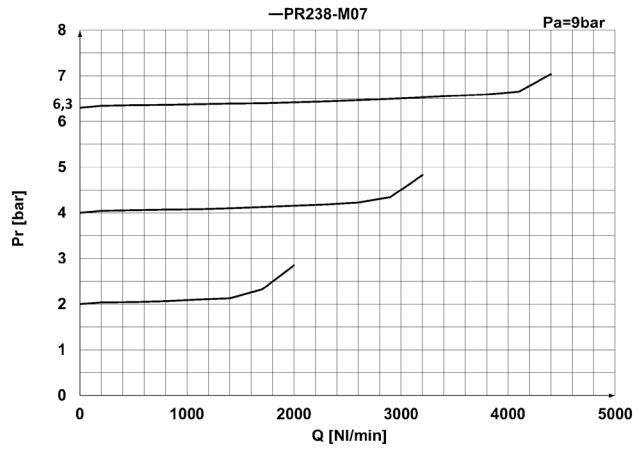

EXHAUST FLOW
 Pr = Regulated pressure (bar)
 Q = Flow (NL/min)
 Pa = Inlet pressure (bar)

FLOW DIAGRAMS Mod. PR238-M04

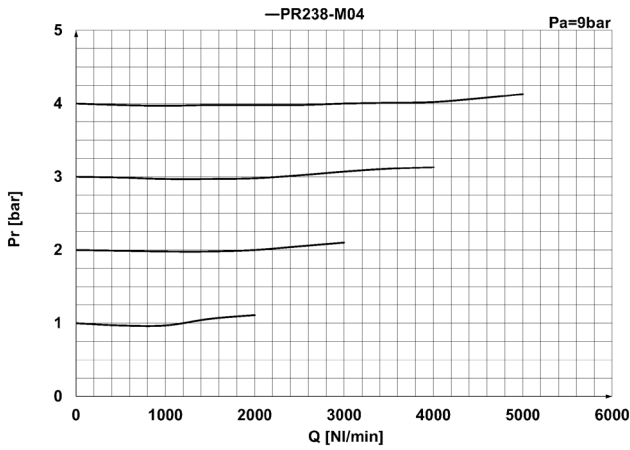

Pr = Regulated pressure (bar)
 Q = Flow (NL/min)
 Pa = Inlet pressure (bar)

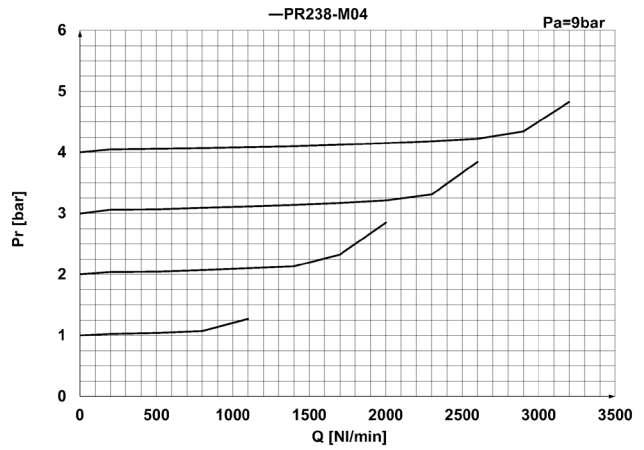

EXHAUST FLOW
 Pr = Regulated pressure (bar)
 Q = Flow (NL/min)
 Pa = Inlet pressure (bar)

FLOW DIAGRAMS Mod. PR238-M02

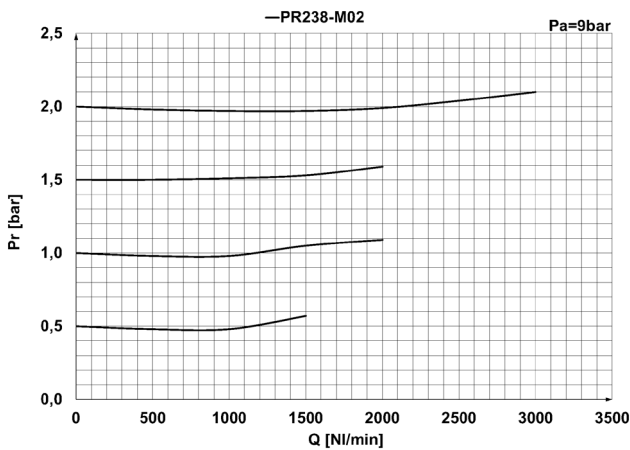

Pr = Regulated pressure (bar)
 Q = Flow (NL/min)
 Pa = Inlet pressure (bar)

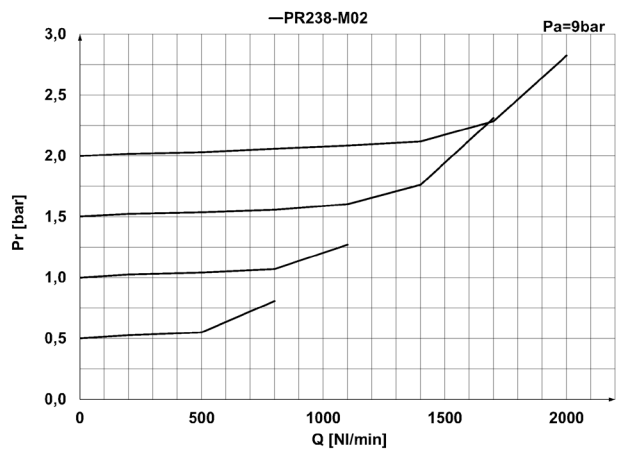

EXHAUST FLOW
 Pr = Regulated pressure (bar)
 Q = Flow (NL/min)
 Pa = Inlet pressure (bar)

Series CLR micro pressure regulators

Ports G1/4, G1/8
With banjo stem with or without relieving
Available with or without banjo



Series CLR micro pressure regulators are available with G1/8 and G1/4 connections. A piston with or without relieving and VS function (by-pass valve) has been incorporated into its design. The body is in brass, while the connection fitting is in technopolymer which guarantees maximum lightness. They can be supplied with or without banjo and can be console mounted.

With a threaded top part of the body both direct mounting to a valve outlet (1/8 and 1/4 threads) and console mounting are easily facilitated. The pressure is precisely regulated simply by turning the polymer knob with a locking nut available to set the desired output.

- » Extremely lightweight
- » Compact
- » In-line or console mounting

GENERAL DATA

Construction	piston
Materials	brass body, technopolymer banjo, stainless steel spring; NBR O-ring
Ports	G1/8 - G1/4
Weight	Kg 0,035
Mounting	in-line or panel mounting (in any position)
Operating temperature	-5°C ÷ 50°C (with the dew point of the fluid lower than 2°C at the min. working temperature)
Inlet pressure	2 ÷ 10 bar
Outlet pressure	0,5 ÷ 10 bar
Nominal flow	see FLOW DIAGRAMS on the following pages
Secondary pressure (relieving)	with relieving (standard) without relieving (all regulators are provided with high relief flow VS function)

CODING EXAMPLE

CL	R		1/8	-	01	-	4
CL	SERIES:						
R	R = REGULATOR						
1/8	PORTS: 1/8 = G1/8 1/4 = G1/4						
01	DESIGN TYPE: = with relieving 01 = without relieving						
4	TUBE: = without banjo 4 = single technopolymer banjo with tube diameter Ø4 mm (only CLR 1/8) 6 = single technopolymer banjo with tube diameter Ø6 mm 8 = single technopolymer banjo with tube diameter Ø8 mm 1/8L = single metal banjo with thread G1/8 (only CLR 1/8) 1/8D = double metal banjo with double thread G1/8 (only CLR 1/8)						

SERIES CLR MICRO PRESSURE REGULATORS

FLOW DIAGRAMS at 6 bar with ΔP1

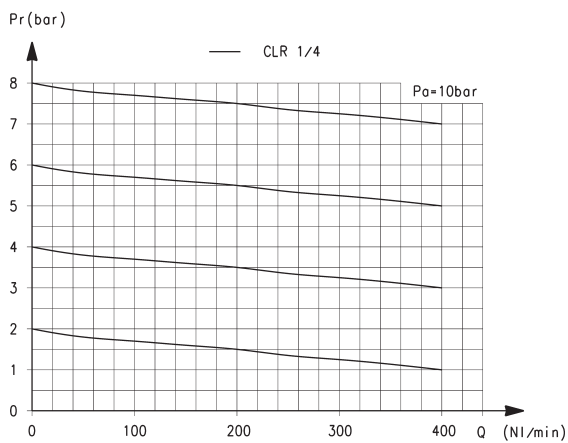

Pa = Inlet pressure (bar)
Pr = Regulated pressure (bar)
Q = Flow (NL/min)

CLR 1/4-6 = 209 NL/min
CLR 1/4-8 = 310 NL/min

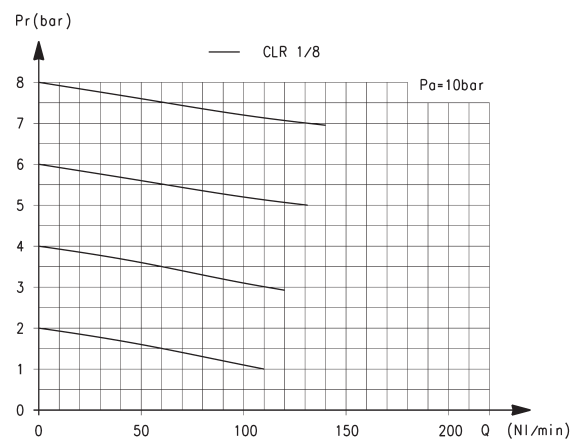

Pa = Inlet pressure (bar)
Pr = Regulated pressure (bar)
Q = Flow (NL/min)

CLR 1/8-4 = 90 NL/min
CLR 1/8-6 = 120 NL/min
CLR 1/8-8 = 120 NL/min

Series CLR Micro pressure regulators with banjo

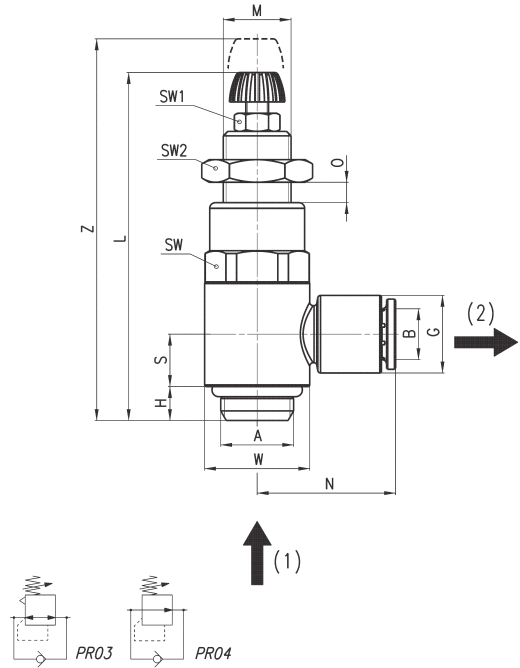

Mod.	A	B	G	H	L	M	N	O	S	W	SW	SW1	SW2	Z
CLR 1/8-4	G1/8	4	11.6	5	52	M11x1	21	0 ÷ 6.5	7.75	14	14	7	14	59
CLR 1/8-6	G1/8	6	11.6	5	52	M11x1	21	0 ÷ 6.5	7.75	14	14	7	14	59
CLR 1/8-8	G1/8	8	13.9	5	52	M11x1	22.5	0 ÷ 6.5	7.75	14	14	7	14	59
CLR 1/4-6	G1/4	6	13.9	6	59.5	M12x1	24.5	0 ÷ 8	9.25	18.6	17	7	17	68
CLR 1/4-8	G1/4	8	13.9	6	59.5	M12x1	24.5	0 ÷ 8	9.25	18.6	17	7	17	68

DRAWING NOTE
(1) = inlet pressure
(2) = regulated pressure

PR03 = Regulator with relieving and by-pass valve
PR04 = Regulator without relieving and with by-pass valve

Series CLR Micro pressure regulators without banjo

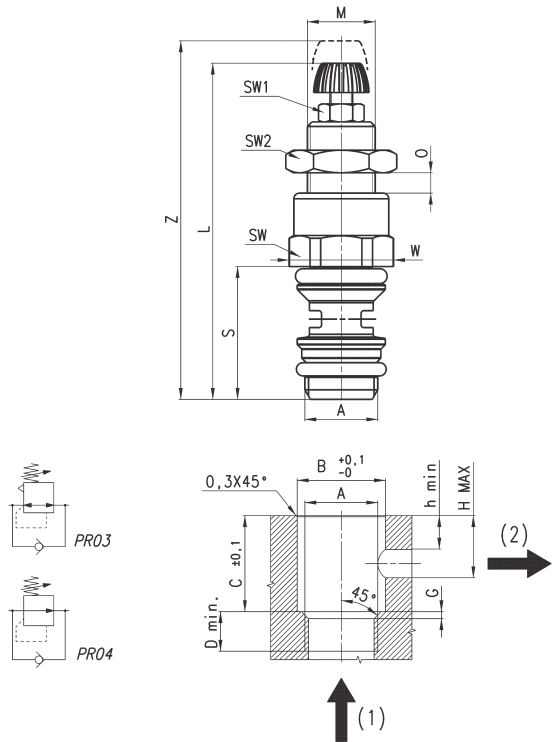

DIMENSIONS																
Mod.	A	B	C	D min	G	h min	H MAX	L	M	O	S	W	SW	SW1	SW2	Z
CLR 1/8	G1/8	11	15.5	6	1	5.5	10	52	M11x1	0 ÷ 6.5	20.5	15.2	14	7	14	59
CLR 1/4	G1/4	15.65	18.5	7	1.25	7	12	59.5	M12x1	0 ÷ 8	24.5	18.5	17	7	17	68

DRAWING NOTE
(1) = inlet pressure
(2) = regulated pressure

PR03 = Regulator with relieving and by-pass valve
PR04 = Regulator without relieving and with by-pass valve

Series CLR Micro pressure regulators with double banjo

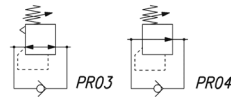
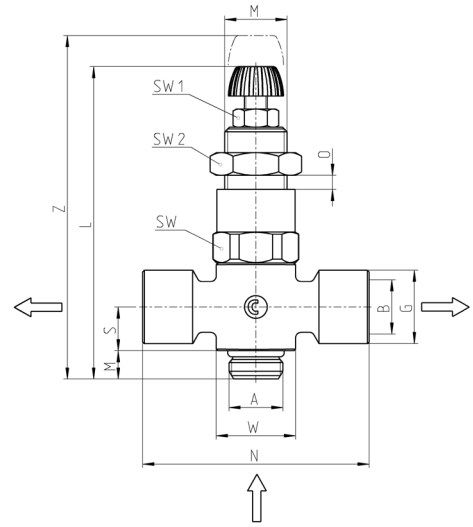

Mod.	A	B	G	H	L	M	N	O	S	W	SW	SW1	SW2	Z
CLR 1/8-1/8D	G1/8	G1/8	13	5	52	M11x1	40	0 ÷ 6.5	7.75	14	14	7	14	59

DRAWING NOTE
 (1) = inlet pressure
 (2) = regulated pressure

PR03 = Regulator with relieving and by-pass valve
 PR04 = Regulator without relieving and with by-pass valve

Series CLR Micro pressure regulators with banjo

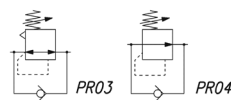
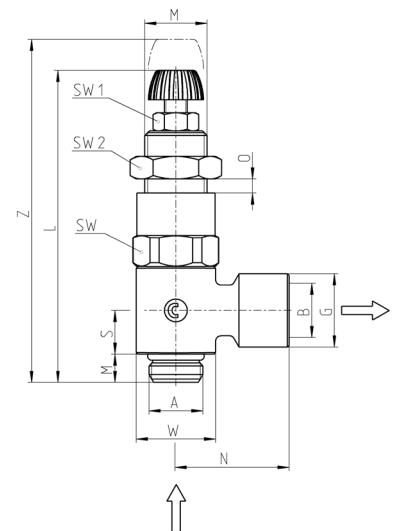

Mod.	A	B	G	H	L	M	N	O	S	W	SW	SW1	SW2	Z
CLR 1/8-1/8L	G1/8	G1/8	13	5	52	M11x1	20	0 ÷ 6.5	7.75	14	14	7	14	59

DRAWING NOTE
 (1) = inlet pressure
 (2) = regulated pressure

PR03 = Regulator with relieving and by-pass valve
 PR04 = Regulator without relieving and with by-pass valve

Series M pressure microregulators for use with water and fluids

Ports G1/8, G1/4

SERIES M PRESSURE MICROREGULATORS



- » Versions with certified diaphragms and seals materials available
- » Version with non nickel-plated body for applications with water or fluids (gaseous or liquid) available

Series M pressure regulator is available with G1/8 and G1/4 ports.

The versions with non nickel-plated body are equipped with KTW certified seals and can be thus used with water or non aggressive fluids.

GENERAL DATA

Construction	diaphragm type
Materials	body: non nickel-plated brass spring: stainless steel seals: diaphragm in EPDM (H versions only)
Ports	G1/8 - G1/4
Weight	Kg 0.235
Pressure gauge ports	G1/8
Mounting	in-line or panel mounting (in any position)
Operating temperature	10°C ÷ 50°C with water
Inlet pressure	0 ÷ 16 bar
Outlet pressure	0.5 ÷ 10 bar
Nominal flow	air: Qn 480 (NL/min) water: Kv 0.42 (N3h)

CODING EXAMPLE

M	0	04	-	R	0	1	-	H
M	SERIES							
0	SIZE							
04	PORTS: 08 = G1/8 04 = G1/4							
R	REGULATOR							
0	OPERATING PRESSURE: 0 = 0.5 ÷ 10 bar							
1	DESIGN TYPE: 1 = non relieving							
H	VERSION: H = for use with water F = for use with various fluids							

SERIES M PRESSURE MICROREGULATORS

Series M pressure microregulator

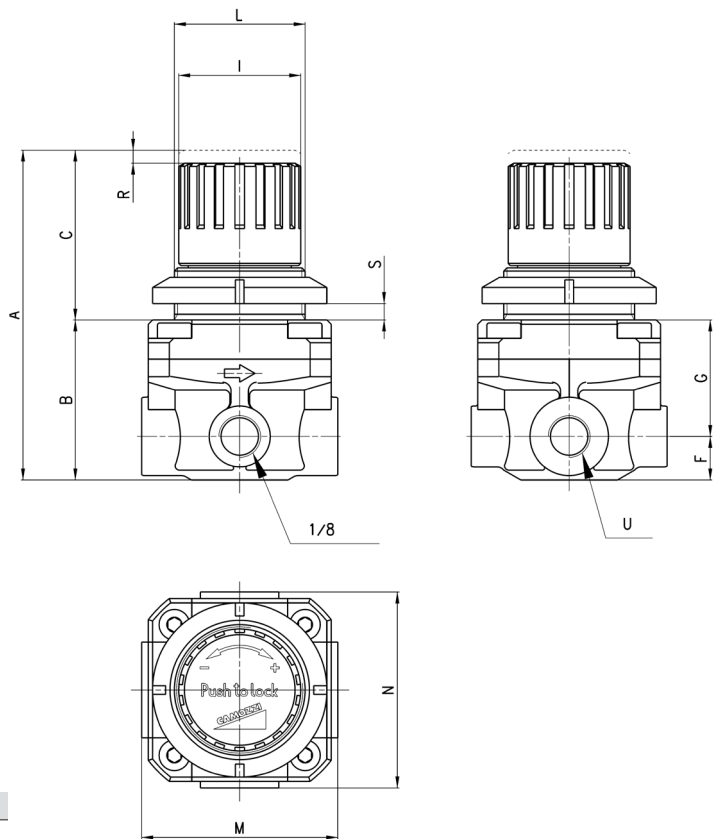

DIMENSIONS												
Mod.	A	B	C	F	G	I	L	M	N	R	S	U
M008-R01-H	76	37	39	10	27	28	M30x1,5	45	45	3	0 ÷ 6	G1/8
M008-R01-F	76	37	39	10	27	28	M30x1,5	45	45	3	0 ÷ 6	G1/8
M004-R01-H	76	37	39	10	27	28	M30x1,5	45	45	3	0 ÷ 6	G1/4
M004-R01-F	76	37	39	10	27	28	M30x1,5	45	45	3	0 ÷ 6	G1/4

Series T pressure microregulators

Ports G1/8 and G1/4



- » Extremely lightweight
- » Compact
- » In-line or console mounting

All models are equipped with a by-pass valve which is useful when a regulator should be inserted between the valve and cylinder (or capacity) without any negative influence on the exhaust.

Series T pressure regulators are available with G1/8 and G1/4 brass connections. A self-relieving piston has been incorporated into the design to allow decreasing adjustments. Non-relieving versions are also available.

GENERAL DATA

Construction	piston
Materials	technopolymer body and piston, stainless steel spring, brass inserts, NBR O-ring and poppet
Ports	G1/8 - G1/4
Weight	g 95
Pressure gauge ports	G1/8
Mounting	in-line or panel mounting (in any position)
Operating temperature	-5 °C ÷ 50 °C (with the dew point of the fluid lower than 2°C at the min. working temperature)
Inlet pressure	0 ÷ 12 bar
Outlet pressure	0.5 ÷ 10 bar
Nominal flow	see graphs
Secondary pressure relieving	standard
Type of fluid	air and water. Special versions for other types of gas are available upon request.

CODING EXAMPLE

T	1	08	-	R	0	0
T	SERIES					
1	SIZE					
08	PORTS: 08 = G1/8 04 = G1/4					
R	REGULATOR					
0	OPERATING PRESSURE: 0 = 0,5 ÷ 10 1 = 0 ÷ 4 2 = 0 ÷ 2 7 = 0 ÷ 7 (standard)					
0	DESIGN TYPE: 0 = self-relieving 1 = non relieving					

SERIES T PRESSURE MICROREGULATORS

FLOW DIAGRAMS

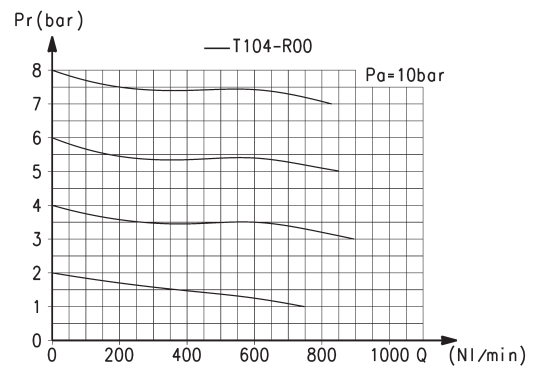
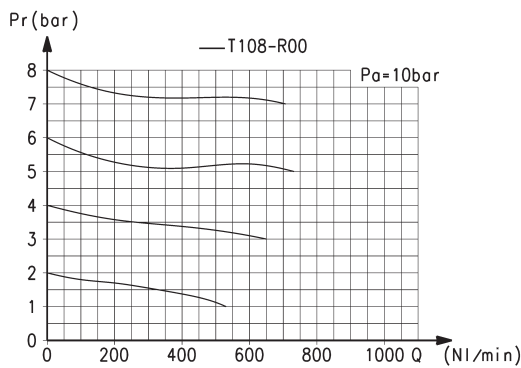

Flow diagram for model: T108-R00
Pa = Inlet pressure (bar)
Pr = Regulated pressure (bar)
Q = Flow (NI/min)

Flow diagram for model: T104-R00
Pa = Inlet pressure (bar)
Pr = Regulated pressure (bar)
Q = Flow (NI/min)

Series T pressure microregulator

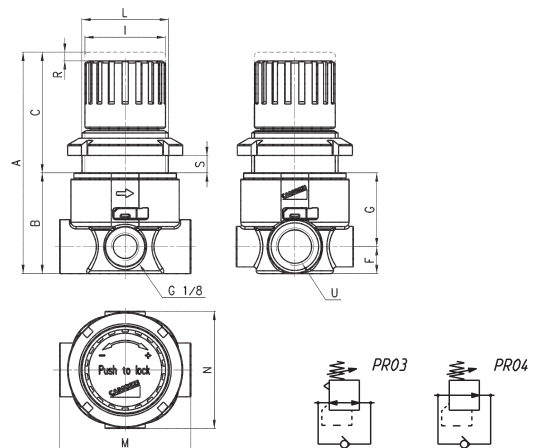

DIMENSIONS												
Mod.	A	B	C	F	G	I	L	M	N	R	S	U
T108-R00	77	35	42	9.5	25.5	28	M30X1.5	46	41	3	7	G1/8
T104-R00	77	35	42	9.5	25.5	28	M30X1.5	46	41	3	7	G1/4

PR03 = regulator with relieving and by-pass valve

PR04 = regulator without relieving and with by-pass valve

Series PG digital pressure gauges

Possibility of a direct mounting with rear or panel connection

SERIES PG DIGITAL PRESSURE GAUGES



- » Pressure unit on display
- » Battery-powered / with cable
- » Easy and fast read out with digital display
- » 4 user programmable pressure units available
- » Power saving mode
- » Back light
- » Dust-proof and splash-proof (IP65 protection class)

The new Series PG digital pressure gauges meet the need of an even more precise pressure adjustment, above all in proportional control. Thanks to the IP65 protection class these pressure gauges are particularly suitable for applications where the highest environmental protection is required.

TECHNICAL DATA

CHARACTERISTICS		
	Vacuum PG...-VB...	Pressure PG...-PB...
Pressure units	psi, bar, mmHg, kPa programmable by the user	psi, bar, kgf/cm ² , MPa programmable by the user
Rated pressure range	0 ÷ -1 bar	0 ÷ 10 bar
Display pressure range	0.1 ÷ -1 bar	-0.1 ÷ 10 bar
Withstand pressure	3 bar	15 bar
Repeatability	≤ ± 1% F.S. ± 1 digit	≤ ± 0,2% F.S. ± 1 digit
Resolution: kPa	1	-
MPa	-	0.001
kgf/cm ²	0.01	0.01
bar	0.01	0.01
psi	0.1	0.1
Indicator accuracy	≤ ± 2% F.S. ± 1 digit (ambient temperature: 25 ± 3°C)	
Medium	Filtered air, incombustible and non-corrosive gases	
Back light	Yes	
Sample rate	2 Hz (2 times/second)	
LCD display	3 ½ digit, 7 segment	
Environment: Protection class	IP65 (an air tube must be installed to maintain this grade)	
Temperature	Operation: 0 ÷ 50°C Storage: -10 ÷ 60°C (no condensation or freezing)	
Relative humidity	Operation/storage: 35 ÷ 85% RH (no condensation)	
Vibrations	Total amplitude 1.5mm or 10G 10Hz-55Hz-10Hz scan for 1 minute 2 hours for each direction of X, Y and Z	
Shock	100 m/s ² (10G) 3 times for each direction of X, Y and Z	
Changes due to temperature	≤ ± 2% F.S. of detected pressure (25°C) within the operating temperature range	
Pneumatic connections ports	G1/4 - M5 or G1/8 - M5	
FOR BATTERY-POWERED PRESSURE GAUGES ONLY		
Battery: Type	CR 2032 lithium	
Life	1 year (5 times/day)	
Low-power indicator	Yes	
Replacement	Yes	
Turn-on interval	Display turns off after 60 seconds	
FOR PRESSURE GAUGES WITH POWER SUPPLY CABLE ONLY		
Supply voltage	from 12 to 28 V DC ± 10% Ripple	
Power consumption	10 mA	
Maximum voltage	1000V AC in 1-min (between the casing and the cables)	
Isolation resistance	50 Mohm min (at 500 V DC, between the casing and the cables)	
Electrical connection: for pressure gauges PG...-2	Unshielded 2-pole cable, length 2 m	
for pressure gauges PG...-M	Connection with M8 4-pole connector	

CODING EXAMPLE

PG	010	-	P	B	-	1/8	-	2
PG	SERIES							
010	BOTTOM SCALE: 010 = 10 bar 001 = -1 bar							
P	PRESSURE RANGE: P = pressure V = vacuum							
B	LIGHTING: B = back light							
1/8	PNEUMATIC CONNECTIONS: 1/8 = G 1/8 BSPP; M5 1/4 = G 1/4 BSPP; M5 (for battery-powered version only)							
2	ELECTRICAL CONNECTION (for version with cable only): 2 = with unshielded 2-pole cable of 2 m M = with cable of 150 mm and M8 4-pole connector							

SERIES PG DIGITAL PRESSURE GAUGES

Series PG digital pressure gauges - battery-powered

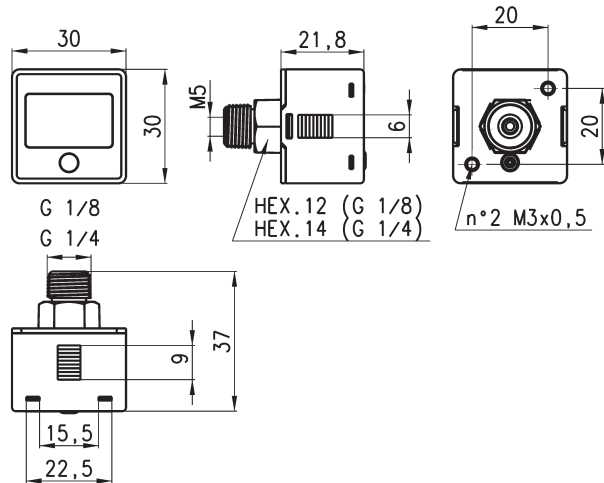

Mod.
PG010-PB-1/8
PG001-VB-1/8
PG010-PB-1/4
PG001-VB-1/4

Series PG digital pressure gauges - with cable

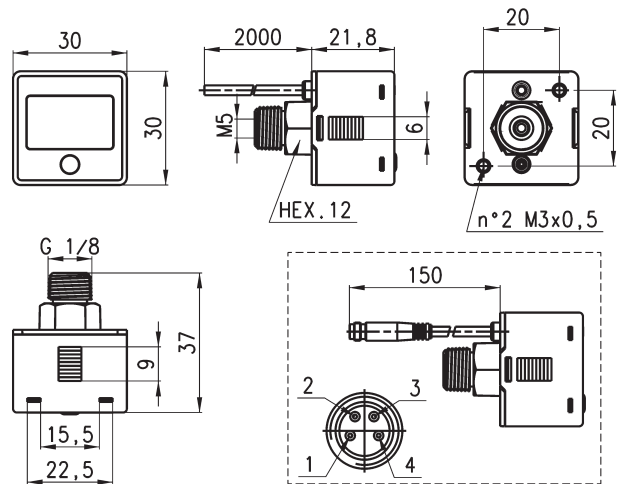

Mod.
PG010-PB-1/8-2
PG001-VB-1/8-2
PG010-PB-1/8-M
PG001-VB-1/8-M

Mounting brackets Mod. PG-B



Supplied with:
 1x bracket type A
 1x bracket type B
 2x screws M3x6

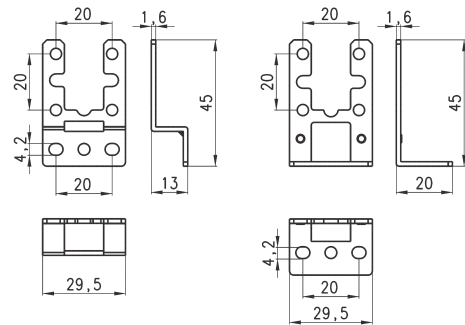

Mod.
PG-B

Panel mounting adapter Mod. PG-F



Supplied with:
 1x adapter type A
 1x adapter type B

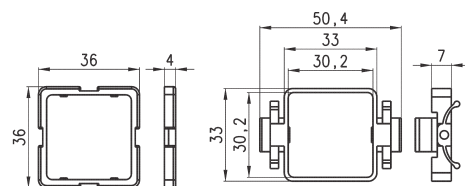

Mod.
PG-F

New

OX1 fittings and accessories for applications of medical gases

Tube external diameters: 4, 6 and 8 mm
Fittings threads: metric (M5), BSP (G1/8, G1/4), BSPT (R1/8, R1/4)

OX1 FITTINGS AND ACCESSORIES FOR APPLICATIONS OF MEDICAL GASES



OX1 fittings are designed for the Life Science market, particularly for medical and analytical applications. Equipment manufacturers of Ventilators, Anaesthesia devices, Oxygen Concentrators, Mass Spectrometry or Bio Medical analysers have qualified the Series OX1 fittings for many years.

OX1 Products Cleanliness level:
Non volatile residue equal to or less than 550 mg/m²
Level OX1 : ultrasonic cleaning of components, inspection with UV black light, lubrication with a specific grease suitable to be used with oxygen.

- » Ultrasonic cleaning
- » Oxygen suitable grease
- » Approved Collet technology
- » Long life service
- » Use with PA, PU, PE or Fluoropolymer Tubings

Serie 6000 OX1 push in fittings:
Series 6000 OX1 super-rapid fittings have been designed with a special collet which provides an homogeneous tight on the whole surface of plastic tubes, thus ensuring high reliability and a long service life, also after connections and disconnections of the tube are repeated several times.

Serie VNR OX1 unidirectional valves:
They are available with Integrated Push-in Fittings. Thanks to their construction they operate at low pressure.

Serie 2000 OX1 brass pipe fittings:
The wide range of Camozzi pipe fittings, which includes straight, L and Tee, male or female couplings, guarantees the necessary support during the design of medical and analytical systems.

GENERAL CHARACTERISTICS

Series 6000	
Diameters	∅ 4, 6 and 8mm
Threads	GAS cylindrical ISO 228 (BSP); M5
Temperature	-15 °C ÷ 80 °C (see the technical data of tubing used)
Tube to connect	Polyamide (PA) 6 - 11 - 12, Polyurethane (PU), Fluoropolymer (FEP)
Fluid	Oxygen, Medical Gases, Compressed Air or Other low pressure fluids
Materials	Standard models: body and collet in nickel-plated brass, O-ring with FKM with Oxygen suitable grease.
Working pressure	Standard models: min -0,9 bar - max 16 bar (see tubing)

Series VNR	
Valve group	automatic valves
Construction	poppet-type
Materials	brass body stainless steel spring FKM seals
Mounting	in any position
Dimensions tube version	∅4; ∅6; ∅8
Operating temperature	0 °C ÷ 80 °C
Fluid	Oxygen, Medical Gases, Compressed Air or Other low pressure fluids

Series 2000	
Threads	GAS conical ISO 7 (BSPT) GAS cylindrical ISO 228 (BSP)
Temperature	-40 °C ÷ 120 °C
Fluid	Oxygen, Medical Gases, Compressed Air or Other low pressure fluids
Materials	nickel-plated brass
Working pressure	80 bar

OX1 FITTINGS AND ACCESSORIES FOR APPLICATIONS OF MEDICAL GASES

Fittings Mod. 6512-OX1

New

Metric-BSP Male Connector

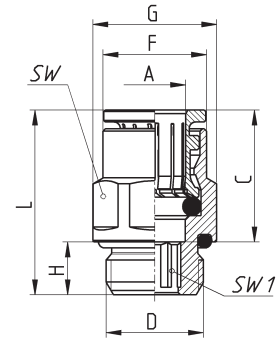

DIMENSIONS										
Mod.	A	D	C	F	G	H	L	SW	SW1	Weight (g)
6512 4-M5-OX1	4	M5	14.0	7.8	8.8	4	20	8	2	4
6512 4-1/8-OX1	4	G1/8	14.0	8.8	13.5	6	19	12	2.5	10
6512 6-M5-OX1	6	M5	16.0	11.7	13.2	4	22	12	2	8
6512 6-1/8-OX1	6	G1/8	16.0	11.7	13.5	6	21	12	4	10
6512 6-1/4-OX1	6	G1/4	16.0	11.7	16.4	7	22	15	4	13
6512 8-1/8-OX1	8	G1/8	17.5	13.7	15.2	6	26	14	5	15
6512 8-1/4-OX1	8	G1/4	17.5	13.7	16.4	7	24.5	15	6	17

Fittings Mod. 6700-OX1

New

Cartridge

S* = for both metallic and synthetic seat

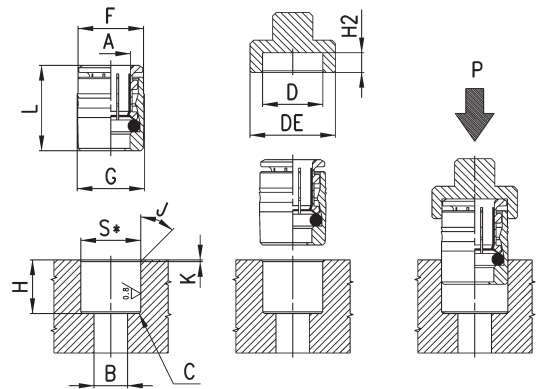

Mod.	A	B	C	D	DE	F	G	H	H2	J	K	L	P min	P max	S (+0,01/-0,04)	Weight (g)
6700 4-OX1	4	3.5	0.5x45°	8.8	14	8.6	9	11	3.3	15°	0.5	14.5	200	360	8.75	4
6700 6-OX1	6	4	0.5x45°	12	17	11.8	12.2	12	3.8	15°	0.5	16.5	160	570	11.95	8

Fittings Mod. 6463-OX1

New

Metric-BSP Female Connector

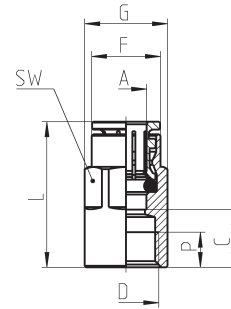

DIMENSIONS									
Mod.	A	D	C	F	G	L	P (min)	SW	Weight (g)
6463 4-1/8-OX1	4	G1/8	10	9	13	24	6	12	14
6463 6-1/8-OX1	6	G1/8	10	11.7	13	26	6	12	14
6463 6-1/4-OX1	6	G1/4	11.5	11.9	16.5	27.5	7	15	23

Fittings Mod. 6522-OX1

New

Metric-BSP Swivel Male Elbow

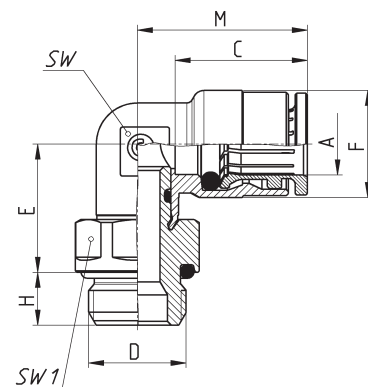

DIMENSIONS										
Mod.	A	D	C	E	F	H	M	SW	SW1	Weight (g)
6522 4-M5-OX1	4	M5	14.0	12.5	9	4	17.5	8	8	12
6522 4-1/8-OX1	4	G1/8	14.0	14.5	9	6	17.5	8	12	15
6522 6-M5-OX1	6	M5	16.0	13	12.7	4	20	9	10	14
6522 6-1/8-OX1	6	G1/8	16.0	15	12.7	6	20	9	12	19
6522 6-1/4-OX1	6	G1/4	16.0	16	12.7	7	20	9	15	27
6522 8-1/8-OX1	8	G1/8	17.5	16	14.2	6	22.5	11	12	22
6522 8-1/4-OX1	8	G1/4	17.5	17	14.2	7	22.5	11	15	28

Fittings Mod. 6590-OX1

New

Bulkhead Connector

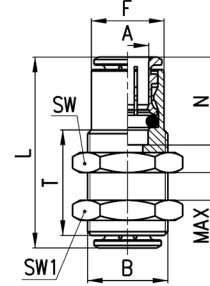

DIMENSIONS										
Mod.	A	B	F	L	N	MAX	SW	SW1	T	Weight (g)
6590 4-OX1	4	M10x1	8.8	29	14	10.5	14	14	20	16
6590 6-OX1	6	M14x1	12.5	33	16	10.5	17	17	20	28

Fittings Mod. 6580-OX1

New

Union Connector

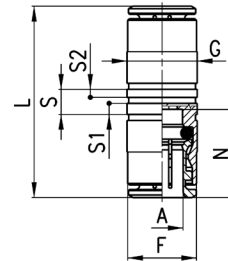

DIMENSIONS										
Mod.	A	F	G	L	N	S	S1	S2	Weight (g)	
6580 4-OX1	4	8.4	9	29	14	5	2.2	1.6	11	
6580 6-OX1	6	11.7	12	34	16	5	2.2	1.6	16	
6580 8-OX1	8	13.7	14	37	17.5	5	2.2	1.6	23	

Fittings Mod. 6550-OX1

New

Elbow connector

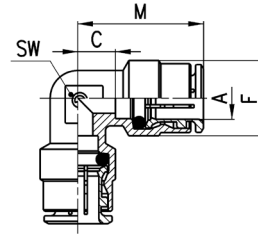

DIMENSIONS						
Mod.	A	C	F	M	SW	Weight (g)
6550 4-OX1	4	3.5	9	17.5	8	8
6550 6-OX1	6	4	12.7	20	9	17

Fittings Mod. 6540-OX1

New

Tee Connector

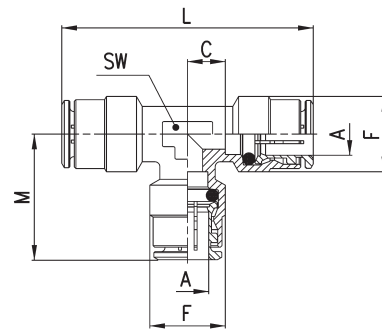

DIMENSIONS							
Mod.	A	C	F	L	M	SW	Weight (g)
6540 4-OX1	4	3.5	9	35	17.5	8	14
6540 6-OX1	6	4	12.7	40	20	9	24

Fittings Mod. 6560-OX1

New



Y Union

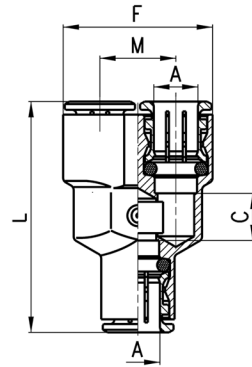

DIMENSIONS						
Mod.	A	C	F	L	M	Weight (g)
6560 4-OX1	4	5	18	33	9	19
6560 6-OX1	6	7	24.5	39	12.5	30

Fittings Mod. 6750-OX1

New



Female Plug

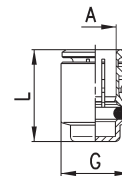

DIMENSIONS				
Mod.	A	G	L	Weight (g)
6750 4-OX1	4	8.8	15	4
6750 6-OX1	6	11.8	17	7

Fittings Mod. 6800-OX1

New



Reducer Junction

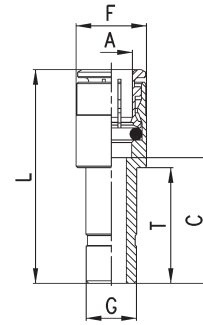

DIMENSIONS							
Mod.	A	G	C	F	L	T	Weight (g)
6800 4-6-OX1	4	6	15.5	9	29.5	18	9
6800 4-8-OX1	4	8	18	9	32	20.5	10
6800 6-8-OX1	6	8	18	12.7	34	20.5	12

Fittings Mod. 6555-OX1

New



Junction Elbow

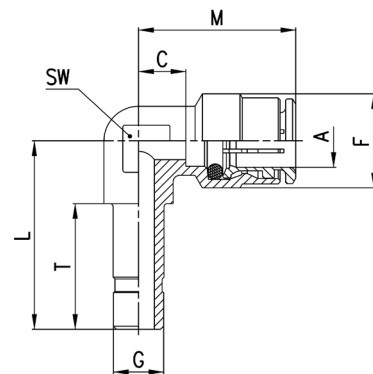

DIMENSIONS										
Mod.	A	G	C	L	F	T	M	SW	Weight (g)	
6555 6-6-OX1	6	6	4	24.5	12.7	18	20	9	14	

Accessory Mod. 6900-OX1

New



Plastic Male Plug

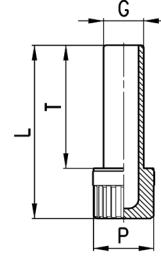

DIMENSIONS					
Mod.	G	L	P	T	Weight (g)
6900 4-OX1	4	29	8	20	1
6900 6-OX1	6	31.5	8	22.5	1

Series VNR unidirectional valves

New

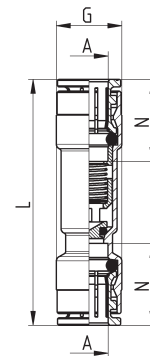

Mod.	A	G	L	N	Flow 6 bar $\Delta P1$ (NL/min)	Min. operating pressure (bar)	Max operating pressure (bar)	Weight (g)
6580 4-VNR-OX1	4	9	40	14	85	0,2	10	13
6580 6-VNR-OX1	6	12	48	16	450	0,2	10	20
6580 8-VNR-OX1	8	14	52.5	17.5	900	0,2	10	30



New

Fittings Mod. 2500-OX1

BSPT Nipple

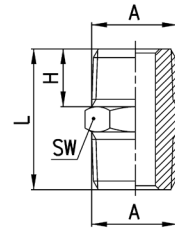

DIMENSIONS					
Mod.	A	H	L	SW	Weight (g)
2500 1/8-OX1	R1/8	7,5	19,5	12	9
2500 1/4-OX1	R1/4	11	27	14	16

New

Fittings Mod. 2501-OX1

Metric-BSP Nipple

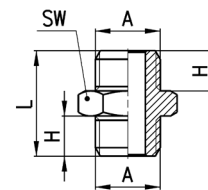

DIMENSIONS					
Mod.	A	H	L	SW	Weight (g)
2501 1/8-OX1	G1/8	6	16,5	13	9
2501 1/4-OX1	G1/4	8	21	17	15

Fittings Mod. 2510-OX1

New

BSPT Reducing Nipple

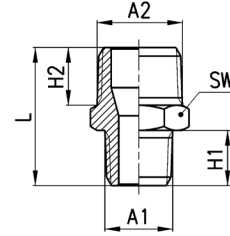

DIMENSIONS							
Mod.	A1	A2	H2	H1	L	SW	Weight (g)
2510 1/8-1/4-OX1	R1/8	R1/4	11	7,5	23,5	14	14

Fittings Mod. 2531-OX1

New

BSP Reducing

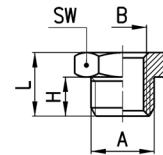

DIMENSIONS							
Mod.	A	B	H	L	SW	Weight (g)	
2531 1/8-M5-OX1	G1/8	M5	6	10,5	13	8	*
2531 1/4-1/8-OX1	G1/4	G1/8	8	13	17	11	*

* = with through-out thread

New

Fittings Mod. 2543-OX1

Sleeve

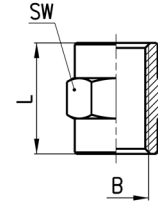

DIMENSIONS				
Mod.	B	L	SW	Weight (g)
2543 M5-OX1	M5	11	8	3
2543 1/8-OX1	G1/8	15	13	8
2543 1/4-OX1	G1/4	22	17	19

New

Fittings Mod. 2611-OX1

BSP Male Plug

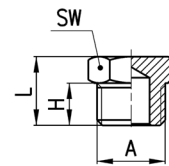

DIMENSIONS					
Mod.	A	H	L	SW	Weight (g)
2611 M5-OX1	M5	4	7,5	8	2
2611 1/8-OX1	G1/8	6	10,5	13	7
2611 1/4-OX1	G1/4	8	13	17	13

Fittings Mod. 2013-OX1

New

BSPT Female Elbow

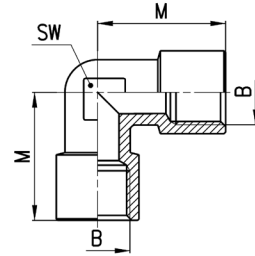

DIMENSIONS				
Mod.	B	M	SW	Weight (g)
2013 1/8-OX1	G1/8	19	11	16
2013 1/4-OX1	G1/4	23	14	28

OX1 FITTINGS AND ACCESSORIES FOR APPLICATIONS OF MEDICAL GASES

Fittings Mod. 2021-OX1 and 2020-OX1

New

Mod. 2021-OX1: Metric Male Female Elbow
Mod. 2020-OX1: BSPT Male Female Elbow

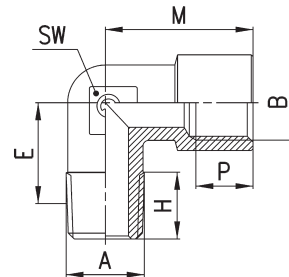

DIMENSIONS								
Mod.	A	B	E	H	M	P (min)	SW	Weight (g)
2020 1/8-1/8-OX1	R1/8	G1/8	11,5	8,5	19	6	11	17
2020 1/4-1/4-OX1	R1/4	G1/4	15	11	23	7	13	27

Fittings Mod. 2003-OX1

New

Female Tee

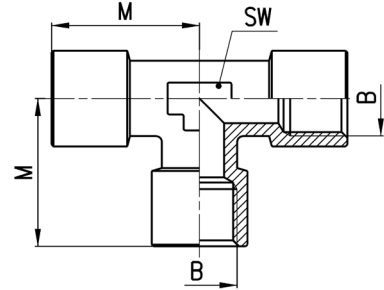

DIMENSIONS				
Mod.	B	M	SW	Weight (g)
2003 1/8-OX1	G1/8	19	12	23
2003 1/4-OX1	G1/4	23	13	39

Fittings Mod. 2043-OX1

New

Female Y

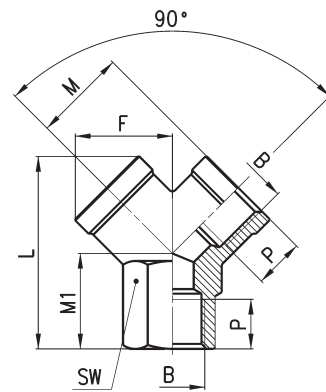

DIMENSIONS								
Mod.	B	F	L	M	M1	P	SW	Weight (g)
2043 1/8-OX1	G1/8	14,5	26,5	14	12	8	13	18
2043 1/4-OX1	G1/4	18	32	17,5	14	11	17	32

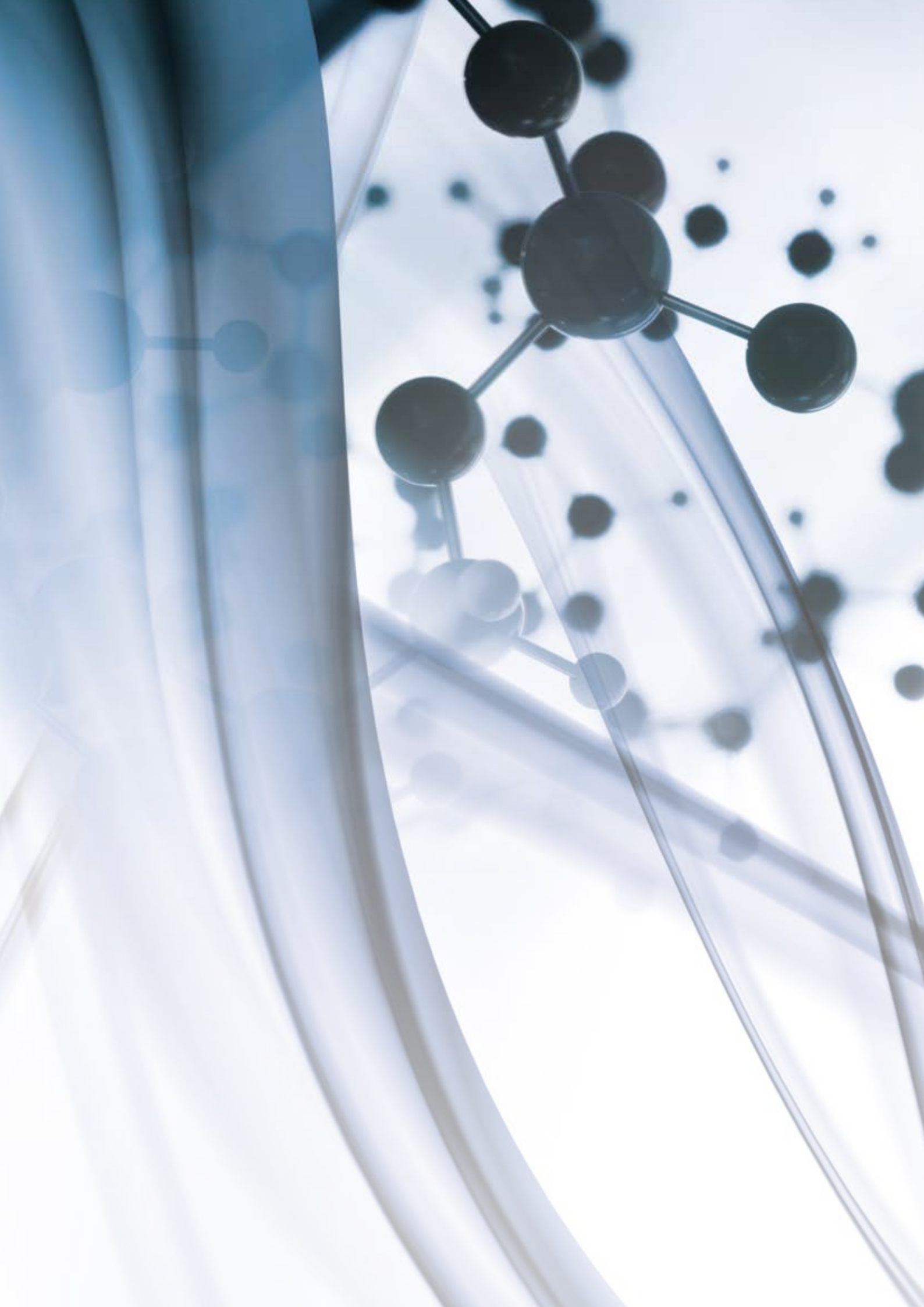

Appendix

Valve islands	a.01
Vacuum and pressure switches	a.02
Series MD modular FRL units	a.03
Fittings	a.04
Chemical compatibility of materials	a.05
Conversion tables	a.07
Flow measuring	a.09
Fluid viscosity	a.09
Solenoid valves dimensioning	a.10
Specifications of Camozzi Clean room	a.10
ATEX Directive 2014/34/EU	a.11
ATEX certified Camozzi products	a.12
IP protection class	a.12
Fluid Control range of products	a.13
BQF (Business Qualification Form)	a.17

Valve islands

The control of actuation is one of the aspects that mostly affect the performance of a pneumatic circuit in industrial applications. Guaranteeing flexible and reliable components and solutions is the

target that Camozzi pursues in the constant development of valve islands, conceived to satisfy all needs in terms of flow, dimensions and performance, both in the multipole and serial versions.

Series D valve islands, Multipole and Fieldbus



- » Integrated pneumatic and electronic connections
- » Valve functions 5/2, 2x3/2 and 5/3-way CC,CP,CO
- » Individual pneumatic module
- » Valve sizes 10, 16, 25 mm
- » Flow rate 280, 950, 2000 NL/min

- » Connection:
 - Multipole with 25 or 44 pins
 - Serial Profibus-Dp, CANopen, DeviceNet, Ethernet/IP, PROFINET, Ethercat IO-Link
- » Coilvision
- » WLAN

Series HN valve islands, Multipole and Fieldbus



- » Multipole connection with 25 or 37 pins
- » Valve functions: 2x2/2; 2x3/2; 5/2; 5/3 CC
- » Valve size: 10,5 and 21mm
- » Valve flow: 400 and 700 NL/min
- » Modular subbases: 2 positions for valve size 10.5mm, single position for valve size 21mm

- » Subbases for monostable and bistable valves (size 10.5mm)
- » Serial connection with the most common communication protocols: PROFIBUS-DP, CANopen, DeviceNet, EtherNet/IP, PROFINET, EtherCAT

Series F valve islands, Multipole and Fieldbus

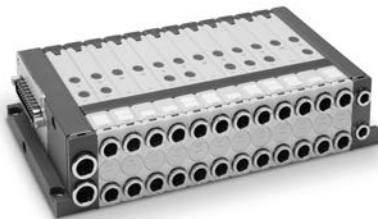

- » Multipole integrated electrical connection (PNP)
- » Valve functions: 2x2/2; 2x3/2; 5/2; 5/3 CC
- » Valve size: 12 and 14mm
- » Modularity: single

- » Valve positions: from 2 to 24
- » Manual override: Push or Push & Turn
- » It can interface with all major serial communication protocols: PROFIBUS-DP, CANopen, DeviceNet, EtherNet/IP, PROFINET, EtherCAT

The complete catalogue of our valve islands is available on the site <http://catalogue.camozzi.com>.

Vacuum and pressure switches

Our range of vacuum and pressure switches includes compact and light solutions, able to satisfy the most different conditions of application and use. The electronic pressure switches with digital display are ideal for safety monitoring and enable the optimization of cycle times or energy saving devices.

Thanks to the programmable switching point and hysteresis, they perfectly suit the customer's needs. The two separate outputs (digital and analog) are programmable and enable the setting of upper and lower limit vacuum values and continuous vacuum control.

Series SWDN electronic vacuum/pressure switches



- » With digital display
- » High precision, easy to use
- » Digital indicator: precision electronic insertion with two separated switch outputs
- » Switching point and hysteresis can be programmed with a membrane keypad
- » Port: with external thread G1/8 and internal thread M5
- » Electric connection: with M8 4-pole connector or pre-wired cable of 2 meters

Series SWCN electronic vacuum/pressure switches



- » With digital display
- » High precision, easy to use
- » Digital indicator: precision electronic insertion with two separated switch outputs
- » Switching point and hysteresis can be programmed with a membrane keypad
- » Upper and lower limit values can be programmed through two PNP switch outputs
- » Port: with external thread G1/8 and internal thread M5
- » Electric connection: with M8 4-pole connector or pre-wired cable of 2 meters

Series MD modular FRL units

The Series MD air preparation product line is characterized by a modern and linear design as well as high performance.

The technopolymer structure has allowed to create a simplified, product, lightweight and robust at the same time.

Filters, coalescing filters, activated carbon filters, regulators and take-off blocks



SERIES MD MODULAR FRL UNITS

Filters:

- » Removal of impurities and condensate
- » Visual blockage indicator
- » Condensate drain options: semi-automatic manual, automatic protected depressurisation, direct G1/8 exhaust
- » Bowl locking system reducing the risk of accidents
- » Additional air intakes with the same characteristics of the outlet air (line)

Coalescing filters:

- » High performance and high purity compressed air
- » Air quality according to ISO 8573-1:2010 standard, Class 1.8.1 and Class 2.8.2

Activated carbon filters:

- » Removal of oil, liquid and gaseous components from compressed air through the active carbons
- » Air quality in compliance with ISO 8573-1 standard, Class 1.7.1

Regulators:

- » Minimal pressure decreases
- » Knob with position lock
- » Tamper-proof system (lockable regulator)
- » With or without overpressure exhaust (relieving)

Take-off blocks:

- » Compact design
- » Utilities orientation

Fittings

Our range of fittings and accessories is composed of numerous series in brass and technopolymer studied in order to respond to the needs of different types of systems. Super-rapid, rapid, universal fittings, accessories and couplings are available in different sizes with threads

ranging from M3 to G1. The patented Sprint® system guarantees tightening even under the worst conditions, with the possibility to repeat the connection and disconnection of the fitting several times.

Series 6000 super-rapid fittings for plastic tubes



- » In ottone nichelato
- » Diametri esterni tubo: 3, 4, 5, 6, 8, 10, 12, 14, 16 mm
- » Filetti dei raccordi: M3, M5, M6, M7, G1/8, G1/4, G3/8, G1/2, G3/4, R1/8, R1/4, R3/8, R1/2

Series 7000 super-rapid Compact fittings



- » In tecnopolimero
- » Diametri esterni tubo: 4, 6, 8, 10, 12, 16 mm
- » Filetti dei raccordi: M5, M7, G1/8, G1/4, G3/8, G1/2, G3/4

Series 8000 dual seal super-rapid fittings



- » In nickel-plated brass
- » Tube external diameters: 4, 6, 8, 10, 12mm
- » Fittings threads: G1/8, G1/4, G3/8, G1/2

Series H8000 fittings with double tightening for harsh environments



- » In nickel-plated brass
- » Diameters: 4, 6, 8, 10, 12, 14, 16mm
- » Fittings threads: Gas cylindrical ISO-228 (BSP)

Series X6000 super-rapid fittings



- » In stainless steel 316L
- » Tube external diameters: 4, 6, 8, 10, 12mm
- » Fittings threads: G1/8, G1/4, G3/8, G1/2, R1/8, R1/4, R3/8, R1/2

Series 1000 rapid push-in fittings for plastic tubes



- » In nickel-plated brass
- » Tube external diameters: 5/3, 6/4, 8/6, 10/8, 12/10, 15/12.5mm
- » Fittings threads: M5, M6, M12 x1, M12 x1.25, G1/8, G1/4, G3/8, G1/2, R1/8, R1/4, R3/8, R1/2

Series 2000 pipe fittings



- » In nickel-plated brass
- » Fittings threads: M5, G1/8, G1/4, G3/8, G1/2, G3/4, G1, R1/8, R1/4, R3/8, R1/2, R3/4, R1

Series 5000 quick-release couplings



- » In nickel-plated brass
- » Nominal diameters: 5.7mm
- » Threads: G1/8, G1/4, G3/8, G1/2

Technical information about the seal materials which are shown in the previous page	
BUNA "N" (NBR-HNBR)	Nitrile rubber. This is a mix of polymers based on butadiene which is being used with aliphatic hydrocarbons (propane, butane, oils and mineral fats, oils and petroleum gas, kerosene), with air, water, soft acids, alcohols and with turpentine. The use of this rubber is not recommended with aromatic essences, polar solvents and with strong acids. NBR shows good mechanical properties and has very high abrasion resistance. On the contrary, it is not resistant to oxygen, ozone and light. Operating temperature: from -20°C to +100°C.
VITON (FPM)	Fluorocarbon rubber. It has excellent resistance to high temperatures, ozone, oxygen and light. It is resistant to mineral oils, fuels, hydraulic fluids, organic solvents and to forced vacuum. On the contrary it is not resistant to halogen hydrocarbons and to freon. It is not recommended to be used at low operating temperature. Operating temperature: from -10°C to +200°C.
NEOPRENE (CR)	Chloroprene rubber. It is suitable for use with alcohols, soft acids, air, water, acetone and neutral gases. It has moderate resistance to oils. It is used in refrigeration systems using oils with high aniline points. Chloroprene shows in general good ozone and aging resistance. It has good mechanical resistance at every working temperature. Operating temperature: from -30°C to +100°C.
E.P.D.M.	Ethylene-propylene-diene rubber derives from the ethylene and propylene copolymerization. It is recommended to be used with hydraulic fluids based on phosphates esters and with brake fluids based on glycols, with hot water and steam with temperatures up 150°C, as well as with polar solvents. It is oxygen, ozone and light resistant. Operating temperature: from -40°C to +130°C.
KALREZ (FFKM - FFKM)	Perfluoro rubber having the same chemical properties as PTFE (TEFLON) and the same elastic properties as FPM (VITON) rubber. It is chemically compatible with almost every chemicals, in particular it is recommended to be used with corrosive fluids. It is oxygen, ozone and aging resistant. It is also suitable for use at high temperatures with forced vacuum. It is not recommended for use with fluorinated combined fluids like freon. Operating temperature: from -20°C to +250°C.
TEFLON (PTFE)	Polytetrafluoroethylene. PTFE has almost absolute chemical resistance. It is not suitable for use with melted alkaline metals, nor with fluorinated combinations at high pressure and high temperature, nor with some halogen units. It doesn't show any particular problem of absorption in the presence of fluids like water. Operating temperature: from -150°C to +180°C.
KEL-F (PCTFE)	Polychlorotrifluoroethylene polymer (CTFE). It is suitable for use with most of corrosive chemicals, organic solvents, hot water and steam, chlorate gases, cryogenic liquids. PCTFE is not recommended for use with some halogen products. It is light and radiation resistant. Operating temperature: from -50°C to +180°C.
SILICONE (Q, MQ, MVQ)	"Silicone rubber" includes various rubber-like materials composed of methyl-vinyl silicone. It is suitable for use with motor or transmission oils and with animal and vegetables fats and oils. It is not recommended to be used with steam, silicone fats and oils, fuels and aromatic hydrocarbons. It is weatherproof, ozone and aging resistant and shows physiologically neutral properties. It has good resistance to low and high temperature. Operating temperature: from -50°C to +190°C.
RUBINO	Synthetic ruby corundum is inert to all the chemical agents and is resistant to high temperatures. Synthetic ruby is generally used as siphon nozzle, batching plant nozzles, burner nozzles and valves.
POLIURETANO (PUR)	Polyurethane rubber can be, according to its poly oil components, both in polyester-urethane (AU) and in polyeter-urethane (EU). The last one shows better resistance to hydrolysis and it is used with pure aliphatic hydrocarbons, oils and mineral fats or with silicone, as well as with water temperatures of up to 50°C. It is not recommended to be used with hot water and with steam, esters and eters, alcohols and glycols. Polyurethane shows excellent abrasion resistance compared with other elastomers and has great elasticity. It has also excellent ozone and aging resistance. Operating temperature: from -30°C to +80°C.

Conversion tables

Systems of measurement

LENGTH				
	meter	inch	foot	yard
1 m	1	39,37	3,2808	1,0936
1 in	0,0254	1	0,0833	0,0278
1 ft	0,3048	12	1	0,033
1 yd	0,9144	36	3	1

 $1 \text{ m} = 10^3 \text{ km} = 10 \text{ dm} = 10^2 \text{ cm} = 10^3 \text{ mm} = 10^6 \text{ }\mu\text{m} = 10^{12} \text{ nm}$

MASS				
	kilogram	pound	tons short (US)	long (Imp)
1 kg	1	2,205	$1,102 \cdot 10^{-3}$	$0,9843 \cdot 10^{-3}$
1 lb	0,4536	1	$0,500 \cdot 10^{-3}$	$0,4464 \cdot 10^{-3}$
1 short ton (US)	907,2	2000	1	0,8929
1 long ton (Imp)	1016	2240	1,12	1

 $1 \text{ kg} = 10^3 \text{ g} = 10^2 \text{ dkg}$

AREA					
	cm ²	m ²	sq.inch	sq.foot	sq.yard
1 cm ²	1	$1 \cdot 10^{-4}$	0,155	$1,0764 \cdot 10^{-3}$	$1,196 \cdot 10^{-4}$
1 m ²	$1 \cdot 10^4$	1	1550	10,764	1,196
1 sq in	6,4516	$0,64516 \cdot 10^{-3}$	1	0,00694	$0,772 \cdot 10^{-3}$
1 sq ft	929,0	0,0929	144	1	0,1111
1 sq yd	8360	0,8360	1296	9	1

 $1 \text{ m}^2 = 10^{-6} \text{ km} = 10^{-4} \text{ ha} = 10^2 \text{ dm}^2 = 10^6 \text{ mm}^2$

DENSITY					
	kg/ltr	kg/m ³	pound/cubic foot	pound/gallon Imperial	US
1 kg/ltr	1	1000	62,43	10,022	8,345
1 kg/m ³	0,001	1	0,06243	0,010022	0,008345
1 lb/cu ft	0,01602	16,02	1	0,16054	0,1337
1 lb/gal (Imp)	0,0998	99,78	6,229	1	0,8327
1 lb/gal (US)	0,1198	119,8	7,481	1,201	1

VOLUME						
	liter (dm ³)	m ³	cubic inch	cubic inch	gallons US	Imperial
1 l	1	$1 \cdot 10^{-3}$	61,024	0,03531	0,2642	0,220
1 m ³	1000	1	61024	35,31	264,2	220
1 cu in	$16,387 \cdot 10^{-3}$	$16,387 \cdot 10^{-6}$	1	$0,5787 \cdot 10^{-3}$	$4,329 \cdot 10^{-3}$	$3,606 \cdot 10^{-3}$
1 cu ft	28,320	$28,320 \cdot 10^{-3}$	1728	1	7,481	6,229
1 US gal	3,785	$3,785 \cdot 10^{-3}$	231	0,1337	1	0,8327
1 Imp gal	4,546	$4,546 \cdot 10^{-3}$	277,3	0,1605	1,210	1

Imperial = British

SPECIFIC VOLUME			
	ltr/kg	m ³ /kg	cubic foot/pound
1 ltr/kg	1	0,001	0,01602
1 m ³ /kg	1000	1	16,02
1 cu ft/lb	62,43	0,06243	1

FORCE			
	Newton	kilopound	poundal
1 N	1	0,1020	7,24
1 kp	9,807	1	70,90
1 pdl	0,1383	0,0141	1

 $1 \text{ N} = 10^5 \text{ dyn}$; $1 \text{ dyn} = 1 \text{ g} \times 1 \text{ cm/s}^2$; $1 \text{ kg} = 1 \text{ kg} \times \text{g}$
 $1 \text{ Poundal} = 1 \text{ Pound} \times \text{g}$

PRESSURE									
	1 bar = 10 ⁵ N/m ²	1 at = 1 Kp/cm ²	poundal sq ft	poundal sq in = Psi	1 atm = 760 Torr = 760 mm Hg (0°C)	Hg column (0°C)		H ₂ O column (WC) (4°C)	
						mm Hg = Torr	in Hg	m H ₂ O	ft H ₂ O
1 Pa = 1 N/m ²	1.10 ⁻⁵	1,02.10 ⁻⁵	0,0209	1,45.10 ⁻⁴	9,87.10 ⁻⁶	0,0075	2,95.10 ⁻⁴	1,02.10 ⁻⁴	3,35.10 ⁻⁴
1 bar	1	1,0197	2089	14,504	0,9869	750	29,5	10,20	33,5
1 at	0,980665	1	2048	14,22	0,96784	735,56	29,0	10,00	32,8
1 pdl/sq ft	0,4790.10 ⁻³	0,4882.10 ⁻³	1	6,944.10 ⁻³	0,4725.10 ⁻³	0,359	0,141	4,88.10 ⁻³	0,0160
1 pdl/sq in = Psi	0,06895	0,07031	144	1	0,06806	51,7	2,04	0,703	2,31
1 atm	1,013	1,033	2120	14,70	1	760	29,09	10,33	33,9
1 mm Hg	1,330.10 ⁻³	1,360.10 ⁻³	2,78	0,0193	1,316.10 ⁻³	1	0,0394	0,0136	0,0446
1 in Hg	0,0339	0,0345	70,7	0,4910	0,0334	25,4	1	0,3450	1,133
1 mH ₂ O	0,0981	0,1000	205	1,4220	0,0968	73,6	2,90	1	3,28
1 ft H ₂ O	0,0299	0,0305	62,4	0,4340	0,0295	22,4	0,883	0,3050	1

1 N/m² = Pa (Pascal) = 10 dyn/cm²; 1 kp/m² = 10⁻⁴ kp/cm² = 1 mm WC (a 4°C)

WORK, ENERGY, HEAT CONTENT									
	1 kcal	1 kp m	Btu (British thermal unit)	ft poundal	1 kWh	Horsepower/hour (hph)		on-day of refrigeration	1 Joule = 1 Nm = Ws
						metrical 75 kp m/s h	imperial 550 lb ft/s h		
1 kcal	1	427,0	3,968	3088	1,163.10 ⁻³	1,581.10 ⁻³	1,560.10 ⁻³	13,779.10 ⁻⁶	4190
1 kpm	2,342.10 ⁻³	1	9,294.10 ⁻³	7,233	2,723.10 ⁻⁶	3,704.10 ⁻⁶	3,653.10 ⁻⁶	32,270.10 ⁻⁶	9,807
1 Btu	0,252	107,59	1	778,0	0,293.10 ⁻³	0,398.10 ⁻³	0,393.10 ⁻³	3,472.10 ⁻⁶	1055
1 ft pdl	0,3238.10 ³	0,13826	1,285.10 ⁻³	1	0,377.10 ⁻⁶	0,512.10 ⁻⁶	0,505.10 ⁻⁶	4,462.10 ⁻⁹	1,356
1 kWh	860	367,1.10 ⁻³	3412,8	2,655.10 ⁶	1	1,360	1,341	11,850.10 ⁻³	2,6.10 ⁶
1 PSh	632,3	270.10 ⁻³	2509	1,953.10 ⁶	0,7353	1	0,9863	8,713.10 ⁻³	2,65.10 ⁶
1 hph	641,1	273,7.10 ⁻³	2545	1,980.10 ⁶	0,7457	1,014	1	8,834.10 ⁻³	2,68.10 ⁶
1 ton-day	72,57.10 ⁻³	30,99.10 ⁻³	288.10 ³	244,1.10 ⁶	84,39	144,78	113,2	1	304.10 ⁶
1 J	0,239.10 ⁻³	0,102	0,948.10 ⁻³	0,738	0,278.10 ⁻⁶	0,378.10 ⁻⁶	0,372.10 ⁻⁶	3,280.10 ⁻⁹	1

1 erg = 1 dyn cm = 10⁻⁷ Nm; 1 kJ = 10³J

CAPACITY, ENERGY FLOW, HEAT FLOW									
	1 kcal/h	1 kp m/s	British thermal unit per hour	1 kcal/s = British theor. unit of refrigeration	1 kWh = 1 kJ/s	Horsepower hour (HP)		US Standard commercial ton of refrigeration	British commercial ton of refrigeration
						metrical 75 kp m/s	imperial 550 lb.ft/s		
1 kcal/h	1	0,1186	3,968	0,278.10 ⁻³	1,163.10 ⁻³	1,581.10 ⁻³	1,560.10 ⁻³	0,331.10 ⁻³	0,299.10 ⁻³
1 kp m/s	8,4312	1	33,455	2,342.10 ⁻³	9,804.10 ⁻³	13,333.10 ⁻³	13,150.10 ⁻³	2,792.10 ⁻³	2,520.10 ⁻³
1 Btu/h	0,252	29,89.10 ⁻³	1	0,07.10 ⁻³	0,293.10 ⁻³	0,398.10 ⁻³	0,393.10 ⁻³	0,083.10 ⁻³	75,310.10 ⁻³
1 kcal/s	3600	427,0	14,285.10 ⁻³	1	4,186	5,693	5,615	1,190	1,078
1 kW	860,0	102,0	3414	0,2389	1	1,360	1,341	0,2846	0,2572
1 HP	632,3	75	2509,3	0,1756	0,736	1	0,9863	0,2094	0,1891
1 hp	641,2	76,04	2545	0,1781	0,7455	1,014	1	0,2123	0,21227
1 ton	3024	358,2	12,0.10 ³	0,831	3,513	4,776	4,711	1	0,9037
1 Brton	3340	396,9	13,26.10 ³	0,9277	3,888	5,287	5,214	1,1045	1

ENTHALPY DIFFERENCE, SPECIFIC HEAT			
Δh	kJ/kg	kcal/kg	Btu/pound
1 kJ/kg	1	0,239	0,43
1 kcal/kg	4,19	1	1,80
1 Btu/lb	2,33	0,556	1

1 cal/g = kcal/kg

ENTROPY DIFFERENCE, SPECIFIC HEAT			
Δs	kJ/kg K	kcal/kg °C	Btu/pound °F
1 kJ/kg K	1	0,239	0,239
1 kcal/kg °C	4,19	1	1
1 Btu/lb °F	4,19	1	1

TEMPERATURE
°F = [1,8 · °C] + 32
°C = [°F - 32] · 0,55
°K = °C + 273
°C = degrees Celsius
°K = degrees Kelvin
°F = degrees Fahrenheit

MULTIPLES AND SUB-MULTIPLES		
Name	Symbol	Value
tera	T	10 ¹²
giga	G	10 ⁹
mega	M	10 ⁶
kilo	k	10 ³
etto	h	10 ²
deca	da	10
deci	d	10 ⁻¹
centi	c	10 ⁻²
milli	m	10 ⁻³
micro	μ	10 ⁻⁶
nano	n	10 ⁻⁹
pico	p	10 ⁻¹²

Flow measuring

The flow of gases is indicated in NI/min, of liquids in m³/h.
In fluid valves, the flow is obtained by using a Flow Coefficient Kv.
The Flow Coefficient Kv defines the quantity of water at a temperature between 5°C and 40°C that passes through a valve when there is a Δp of 1 bar between inlet and use.

To find the flow with different liquids, you need to divide the flow calculated with water by the value of kinematic viscosity of the liquid to intercept.

Conversion coefficients

Kv = quantity of water m³/h
kv = quantity of water l/min
Cv = quantity of water Gal/min
Av = flow coefficient m²
Qn = flow rate l/min
S = orifice cross-section mm²

S (mm ²)	ORIFICE (mm)
0,02	0,16
0,2	0,50
0,5	0,80
0,52	0,81
0,54	0,83
0,56	0,84
0,58	0,86
0,6	0,87
0,65	0,91
0,7	0,94
0,75	0,98
0,8	1,01
0,85	1,04
0,9	1,07
0,95	1,10
1	1,13
1,5	1,38
2	1,60
2,5	1,78
3	1,95
3,5	2,11
4	2,26
4,5	2,39
5	2,52
5,5	2,65
6	2,76
6,5	2,88
7	2,99
10	3,57
15	4,37
25	5,64
35	6,68
45	7,57
55	8,37
65	9,10
75	9,77

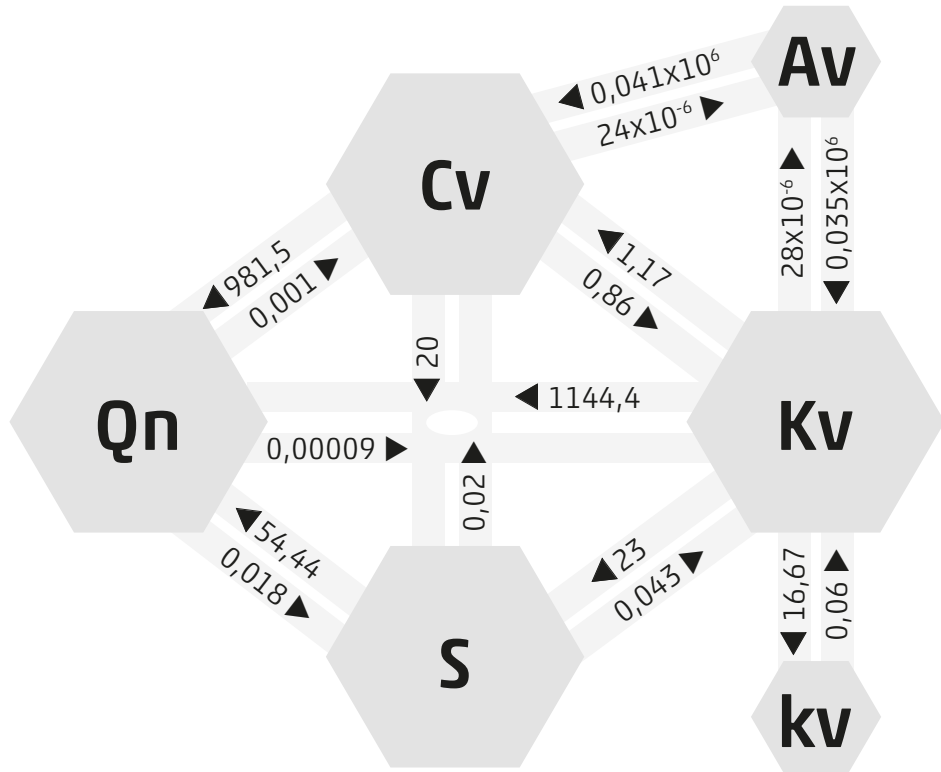

FLOW MEASURING - FLUID VISCOSITY

Fluid viscosity

Not all liquids have the same viscosity, i.e. that characteristic that can be considered a sort of friction inside the liquid that opposes to its flowing. It is the opposite of fluidity. Water runs quicker through a tube than a gel, because it is less viscous than gel.
Viscosity affects the flow and the response times.
Do not confuse Viscosity with Density that is the relation between the Mass of the liquid and the occupied Volume. The Camozzi solenoid valves can be used with fluids with a max. viscosity of 37 cSt.

Viscosity can be of two types: Dynamic and Kinematic.

Dynamic viscosity is proportional to the value of the resisting force that opposes to the flowing of a liquid.
Kinematic viscosity is the relation between Dynamic Viscosity and the Density of the liquid.
In other words, when a liquid passes through a conduct, its speed is minor where it is in contact with the conduct (where there is more friction) and major inside the flow.

Dynamic viscosity is the result of a mathematic calculation that considers the trend of the speed curve inside the tube.

The flowing speed varies according to the Density of liquids, the relation between Dynamic Viscosity and Density gives the value of Kinematic Viscosity.

Dynamic Viscosity can be indicated in

Pa s (Pascal * second)
N s/m²
kg/m s

$$1 \text{ Pa s} = 1 \text{ N s/m}^2 = 1 \text{ kg/m s}$$

Kinematic Viscosity is indicated in St or cSt (Stoke or CentiStokes)

$$\text{St} = 100 \text{ cSt} = 10^{-4} \text{ m}^2/\text{s}$$

Solenoid valves dimensioning

a) Solenoid valves for fluids:

Flow:

$$Q = K_v \cdot \sqrt{\frac{\Delta P}{\gamma}}$$

Flow factor:

$$K_v = Q \cdot \sqrt{\frac{\gamma}{\Delta P}}$$

where:

Q = m³/h

ΔP = bar

γ = Kg/dm³

In case of liquids with viscosity higher than 3°E (22 c Stokes), Kv changes according to the following formula:

$$K_{v_1} = K_v + C$$

where C is the viscosity correction factor that is calculated through the formula:

$$C = \frac{\delta \cdot \sqrt{K_v}}{200 \cdot Q} + 1$$

where:

δ = kinematic viscosity of the fluid in Centistokes

Kv = flow factor of the solenoid valve

Q = flow l/m

Load loss:

$$\Delta P = \gamma \cdot \left(\frac{Q}{K_v} \right)^2$$

b) Solenoid valves for gases:

Se ΔP ≤ 1/2 P₁ use the following formula:

Flow:

$$Q_n = 514 \cdot K_v \cdot \sqrt{\frac{\Delta P \cdot P_2}{\gamma \cdot n \cdot (273 + t)}}$$

Flow factor:

$$K_v = \frac{Q_n}{514} \cdot \sqrt{\frac{(273 + t) \cdot \gamma \cdot n}{\Delta P \cdot P_2}}$$

where:

Qn = Nm³/h

P₁ = bar

P₂ = bar

t = °C

γ n = Kg/m³

Load loss:

$$\Delta P = \frac{(273 + t) \cdot \gamma \cdot n}{P_2} \cdot \frac{Q_n^2}{(514 \cdot K_v)^2}$$

Se ΔP > 1/2 P₁ use the following formula:

$$Q_n = 757 \cdot K_v \cdot \sqrt{\frac{\Delta P \cdot P_2}{(273 + t) \cdot \gamma \cdot n}}$$

Specifications of Camozzi Clean room

Class	maximum number of particles/m ³			FED STD 209E
	≥ 0.5 μm	≥ 1 μm	≥ 5 μm	
ISO 7	352,000	83,200	2,930	Class 10,000

OX1:

non-volatile residue equal to or less than 550 mg/m²
 Level OX1: ultrasonic cleaning of components, inspection with UV black light, lubrication (only if necessary for the product's operation) with a specific grease suitable to be used with oxygen.
 Assembly, testing and packaging outside the clean room.

OX2:

non-volatile residue equal to or less than 33 mg/m²
 Level OX2: ultrasonic cleaning of components, inspection with UV black light, lubrication (only if necessary for the product's operation) with a specific grease suitable to be used with oxygen.
 Assembly, testing and packaging inside a clean room with ISO 7 classification according to ISO 14644-1.



ATEX Directive 2014/34/EU



As from 19 April 2016 all products which are commercialised in the European Union and destined to be used in **potentially explosive atmospheres** have to be approved according to the directive 2014/34/EU, also known as ATEX. This new directive also refers to non-electric items, like pneumatic drives, which need to be approved.

These are the main changes introduced by the new directive 2014/34/EU:

- Also non-electric apparatus and devices, as pneumatic cylinders, are part of the Directive.
 - The apparatus are assigned to different categories which are assigned to certain potentially explosive zones.
 - The products are identified with the CE mark Ex.
 - The instructions for use and the declarations of conformity should in order to be supplied with each sold product used in potentially explosive zones.
 - Products destined to be used in potentially explosive zones, because of the presence of dust, are included in the directive like the products destined to be used in zones with the presence of dangerous gases.
- A potentially explosive atmosphere could be composed of gas, mist, steam or dust which can be created in manufacturing processes or in all those areas in which there is a constant or random presence of inflammable substances. An explosion can occur when there is an existing presence of inflammable substances and an ignition source in a potentially explosive atmosphere.

An ignition source could be:

- Electrical (electric arcs, induced current, heat generated by the Joule effect).
- Mechanical (heat between surfaces caused by friction, sparks generated by the collision of metallic bodies, electrostatic discharges, adiabatic compression).
- Chemical (exothermic reactions between materials).
- Naked flames.

The products which are subject to the approval are those which, during their normal use or because of a malfunction, present one or more ignition sources for the potentially explosive atmospheres.

The producer has to guarantee that the product conforms with the declarations and to the marking of the product. Moreover the product should always be accompanied by the relative instructions. The builder of the equipment and/or user should identify the risk zone in which the products, to which directive 99/92/CE refers, are used and purchase the product according to the use in the pre-determined zone paying attention to the specifications in the relative instructions.

In case a product is composed by two components with different markings, the component which is classified in the lowest category defines the class to which the complete product belongs.

Example:
solenoid suitable for Category 3 marked ...
Ex - II 3 EEx...

and valve suitable for Category 2 ...
Ex - II 2 EEx...
The valve unit with solenoid can be used only in category 3 or zone 2/22

Zones, groups and categories

In the places and for the types of equipment subject to Directive 99/92/CE, the employer should execute the classification of the zones regarding the danger of the creation of explosive atmospheres because of the presence of gas or dust. The apparatus for the use in potentially explosive zones are divided in GROUPS:

GROUP I > apparatus used in mines

GROUP II > apparatus used in installations above the ground

GROUP I: APPARATUS FOR MINES

CATEGORY M1
Functioning in explosive atmosphere

CATEGORY M2
Non-supplied equipment in explosive atmospheres

GROUP II: APPARATUS FOR INDUSTRIES ABOVE THE GROUND

PRODUCT CATEGORY	GAS	DUST
1	Zone 0	Zone 20
2	Zone 1	Zone 21
3	Zone 2	Zone 22

Classification in zones according to Directive 99/92/CE

- Category 1** Zone 0 - Area in which (permanently, for long periods or often) an explosive atmosphere is present, consisting of a mixture of air and inflammables in the form of gas, vapour or mist.
Zone 20 - Area in which (permanently, for long periods or often) an explosive atmosphere is present in the form of a dust/powder cloud which is combustible in the air.
- Category 2** Zone 1 - Area in which, during normal activities, the formation of an explosive atmosphere is probable, consisting of a mixture of air and inflammables in the form of gas, vapours or mist.
Zone 21 - Area in which occasionally during normal activities the formation of an explosive atmosphere is probable, in the form of a dust/powder cloud which is combustible in the air.
- Category 3** Zone 2 - Area in which, during normal activities, the formation of an explosive atmosphere, consisting of a mixture of air and inflammables in the form of gas, vapour or mist is not probable and, whenever this should occur, it is only of a short duration.
Zone 22 - Area in which, during normal activities, the formation of an explosive atmosphere in the form of a combustible dust/powder cloud is not probable and, whenever this should occur, it is only of a short duration.

Example of Marking: II 2 GD c T100°C (T5) -20°C ≤ Ta ≤ 60°C

- II Group: Devices which are to be used in spaces exposed to risks of an explosive atmosphere, different from underground spaces, mines, tunnels, etc., individuated according to the criteria in enclosure I of the Directive 94/9/CE (ATEX)
- 2 Category: Devices designed to function in compliance with the operational parameters determined by the manufacturer and guarantee a high protection level
- GD Protected against gas (G) and explosive powders (D)
- c Non-electrical constructions for potentially explosive atmospheres. Protection through constructive security
- T 100°C Max. superf. temp. of 100 °C reg. potential hazards resulting from striking within the vicinity of hazardous powders
- T5 Max. superf. temp. of 100 °C regarding potential hazards which may result from striking within gassy environments
- Ta Environmental temperature: -20°C ≤ Ta ≤ 60°C. Environmental temperature range (with dry air)

Group I: Temperature classes

Temperature = 150 °C
or = 450 °C according to the level
of dust on the apparatus.

Group II: Temperature classes

Temp. classes for gas (G)	Admissible surface temperatures
T1	450°C
T2	300°C
T3	200°C
T4	135°C
T5	100°C
T6	85°C

ATEX certified Camozzi products

APPARATUS REGARDING ATEX - GROUP II							
Solenoids				Valvole			
Series	Category	Zone	Gas/Dust	Series	Category	Zone	Gas/Dust
U70	3	2/22	G/D	9#*	2	1/21	G/D
U80	2	1/21	G/D	K	3	2/22	G/D
U80I**	2	1/21	G/D	P	3	2/22	G/D
Pressure switches				W	3	2/22	G/D
Series	Category	Zone	Gas/Dust	A#	2	1/21	G/D
PM 11**	1	0/20	G/D	3#	2	1/21	G/D
FRL				4#	2	1/21	G/D
Series	Category	Zone	Gas/Dust	NAMUR#	2	1/21	G/D
MC#	2	1/21	G/D	E (pneumatiche)	2	1/21	G/D
N	2	1/21	G/D	E (elettropneumatiche)	3	2/22	G/D
MX#	2	1/21	G/D	Y	3	2/22	G/D
T	2	1/21	G/D	2	2	1/21	G/D
CLR	2	1/21	G/D	* According ISO			
M	2	1/21	G/D	** Products with ATEX and IECEx certification			
				# Without solenoid			

COMPONENTS REGARDING ATEX - GROUP II			
Products			
Clamp	Category	Zone	Gas/Dust
Silencers	2	1/21	G/D
Quick release couplings	2	1/21	G/D
Manifolds	2	1/21	G/D
Subbases	2	1/21	G/D
Feet	2	1/21	G/D
Caps	2	1/21	G/D
Plates	2	1/21	G/D

» The order code number of the certified products is obtained by adding "EX" to the standard article number
 Es. 358-015 standard solenoid valve
 Es. 358-015EX ATEX certified solenoid valve

Accessories available in category 2 zone 1/21: couplings, junctions, brackets, piston rod nuts, nuts, counter brackets, bushings, pins, clevis pins, caps, gaskets, diaphragm, sub-bases, plates, feet, hand operated valves, flow valves, flanges, screw, tie rods, automatic and blocking valves, silencers and pressure gauge, connector kits, clamps, rapid and super rapid push-in fittings, hoses, sealing rings, locking nuts. Accessories available in category 3, zone 2/22: adaptors, slot covers, extensions, connectors. For more informations on this kind of products see the website: <http://catalogue.camozzi.com> within the section: Downloads > Certifications > ATEX Directive 2014/34/EU > List of products excluded from the directive 2014/34/EU ATEX.

IP protection class

IP 6 5

DEGREE OF PROTECTION AGAINST THE PENETRATION OF LIQUIDS

DEGREE OF PROTECTION AGAINST THE PENETRATION OF FOREIGN BODIES COMING INTO CONTACT WITH LIVE PARTS

DEGREE OF PROTECTION AGAINST THE PENETRATION OF LIQUIDS	DEGREE OF PROTECTION AGAINST THE PENETRATION OF FOREIGN BODIES COMING INTO CONTACT WITH LIVE PARTS	Not protected	Protected against solid bodies greater than Ø 50mm	Protected against solid bodies greater than Ø 12mm	Protected against solid bodies greater than Ø 2.5mm	Protected against solid bodies greater than Ø 1mm	Protected against dust	Totally protected against dust
		IP 0 _X	IP 1 _X	IP 2 _X	IP 3 _X	IP 4 _X	IP 5 _X	IP 6 _X
Not protected	IP _X 0	IP 00	IP 10	IP 20	IP 30	IP 40	IP 50	IP 60
Protected against water falling vertically (condensate)	IP _X 1		IP 11	IP 21	IP 31	IP 41		
Protected against drops of water falling up to 15° off the vertical	IP _X 2		IP 12	IP 22	IP 32	IP 42		
Protected against rain water up to 60° off the vertical	IP _X 3			IP 23	IP 33	IP 43		
Protected against sprays of water from any direction	IP _X 4				IP 34	IP 44	IP 54	
Protected against jets of water fired from any direction	IP _X 5						IP 55	IP 65
Protected against sea waves or the like	IP _X 6							IP 66
Protected against the effects of immersion	IP _X 7							IP 67

Fluid Control range of products

When choosing a valve, it is essential to consider parameters linked to the mechanics of the product and to the environmental conditions of use. The Camozzi range includes many solutions suitable to control different types of fluids with good performances and a high reliability, optimizing consumption

and dimensions. The table on the next page shows the main parameters to evaluate in order to find the most suitable type of valve. Furthermore it is possible to develop customized solutions in order to satisfy the needs of every single client.



	K8 - K8X	K8B	K8DV	K	KL Coming soon	KN	W
COIL SIZE	8 mm	8 mm	8 mm	10 mm	10 mm	10 mm	15 mm
FUNCTION	2/2 - 3/2 NC - NO - UNI	2/2 - 3/2 NC - NO	2/2 NC	2/2 - 3/2 NC - NO	2/2 - 3/2 NC - NO - UNI	3/2 NC - NO - UNI	3/2 NC - NO
OPERATION	direct poppet	servo operated spole	direct diaphragm isolation	direct poppet	direct poppet	direct poppet	direct poppet
PNEUMATIC CONNECTIONS	cartridge barb fittings	cartridge flange M7	cartridge flange	flange	flange ISO 15218	ISO 15218	ISO 15218
ORIFICE DIAMETER	0.5 ... 0.7 mm	3.6 mm	0.7 mm	0.6 ... 1.0 mm	0.6 ... 1.6 mm	0.65 ... 1.1 mm	0.8 ... 1.5 mm
Kv (l/min)	0.08 ... 0.15	2.8	0.1	0.12 ... 0.30	0.12 ... 0.52	0.15 ... 0.39	0.21 ... 0.54
PRESSURE RANGE	-1 ÷ 3 ... 7 bar	1 ÷ 7 bar	0 ÷ 1.5 ... 2.1 bar	0 ÷ 3 ... 7 bar	0 ÷ 3 ... 9 bar	0 ÷ 3 ... 7 bar	0 ÷ 5 ... 10 bar
TEMPERATURE RANGE	0 ÷ 50 °C	0 ÷ 50 °C	5 ÷ 50 °C 20 ÷ 50 °C	0 ÷ 50 °C	0 ÷ 50 °C	0 ÷ 50 °C	0 ÷ 50 °C
MEDIA	inert gas oxygen	inert gas oxygen	inert/aggressive gas/liquid	inert gas oxygen	inert gas	inert gas oxygen	inert gas oxygen
SEALS	FKM	FKM	EPDM FKM FFKM	FKM NBR	FKM	FKM NBR	EPDM FKM PU-NBR
VOLTAGE	3 ... 24 VDC	3 ... 24 VDC	3 ... 24 VDC	6 ... 24 VDC	6 ... 24 VDC	5 ... 24 VDC	12 ... 48 VDC
POWER CONSUMPTION	0.6 W	0.6 W	0.6 W	1 W	1 W 1.3/0.3 W 4/1 W	1.3/0.25 W 4/1 W	1 W 2 W
DUTY CYCLE	ED 100%	ED 100%	ED 100%	ED 100%	ED 100%	ED 100%	ED 100%
ELECTRIC CONNECTION	2 Pins 0.5 x 0.5 connector	2 Pins 0.5 x 0.5 connector	2 Pins 0.5 x 0.5	connector flying leads	connector	connector	connector flying leads



	P	PL	PN	PD	PDV	A	6
COIL SIZE	15 mm	15 mm	15 mm	15 mm	15 mm	22 mm	32 mm
FUNCTION	3/2 NC - NO	2/2 - 3/2 NC - NO - UNI	3/2 NC	2/2 NC	2/2 NC	2/2 - 3/2 NC - NO	2/2 - 3/2 NC - NO
OPERATION	direct poppet	direct poppet	direct poppet	direct poppet	direct diaphragm isolation	direct poppet	direct poppet
PNEUMATIC CONNECTIONS	ISO 15218	flange ISO 15218	flange ISO 15218	flange M5	flange	flange M5-G1/8-R1/8" fitting Ø 4 mm barb fitting Ø 6 mm	flange G1/8 - G3/8 fitting Ø 4 mm
ORIFICE DIAMETER	0.8 ... 1.5 mm	1.1 ... 1.6 mm	0.8 mm	0.8 ... 2.5 mm	0.8 ... 2.0 mm	1.2 ... 2.5 mm	2.0 ... 4.0 mm
Kv (l/min)	0.21 ... 0.54	0.34 ... 0.62	0.19	0.39 ... 1.93	0.25 ... 0.80	0.62 ... 2.0	1.2 ... 5.4
PRESSURE RANGE	0 ÷ 3 ... 10 bar	0 ÷ 3.5 ... 8 bar	0 ÷ 10 bar	-0.9 ÷ 4 ... 12 bar	0 ÷ 1.2 ... 7 bar	-0.9 ÷ 1 ... 15 bar	0 ÷ 4 ... 15 bar
TEMPERATURE RANGE	0 ÷ 50 °C	0 ÷ 50 °C -50 ÷ 50 °C	0 ÷ 50 °C	0 ÷ 50 °C	10 ÷ 50 °C 20 ÷ 50 °C	10 ÷ 60 °C	0 ÷ 60 °C -50 ÷ 50 °C
MEDIA	inert gas oxygen	inert gas oxygen	inert gas	inert gas/liquid oxygen	inert/aggressive gas/liquid	inert gas	inert gas
SEALS	EPDM FKM PU-NBR	FKM NBR	FKM NBR	EPDM FKM NBR	EPDM FKM FFKM	FKM HNBR	FKM NBR
VOLTAGE	12 ... 110 VDC 24 ... 110 VAC	6 ... 110 VDC	24 ... 205 VDC	12 ... 24 VDC	6 ... 24 VDC	12 ... 110 VDC 24 ... 380 VAC	12 ... 110 VDC 24 ... 230 VAC
POWER CONSUMPTION	1 W 2 W	1.2 ... 2.7 W	1 W 2 W	1 ... 4 W	2 W	3 ... 5 W 3.5 ... 7 VA	10 W 19/12 VA
DUTY CYCLE	ED 100%	ED 100%	ED 100%	ED 50% ED 100%	ED 100%	ED 100%	ED 100%
ELECTRIC CONNECTION	connector	connector	connector	connector	connector flying leads	connector	connector

Fluid Control range of products



	CFB	CFB INOX	8 CARTRIDGE	8	TC	ASX	ASP Coming soon	AP
COIL SIZE	22 ... 36 mm	30 mm	pneumatic acting	10 ... 15 mm pneumatic acting	pneumatic acting	pneumatic acting	pneumatic acting	16 mm
FUNCTION	2/2 - 3/2 NC - NO	2/2 - 3/2 NC	2/2 - 3/2 NC	2/2 - 3/2 NC	2/2 NC	2/2 NC - NO - DE	2/2 NC - NO - DE	2/2 PROPO NC
OPERATION	direct / servo poppet diaphragm	direct poppet	direct poppet	direct poppet	direct poppet	direct poppet	direct poppet	poppet
PNEUMATIC CONNECTIONS	G1/8 ... G2	G1/8 ... G1/2	manifold	G1/8 ... G3/8	manifold	1/4 ... 4 thread / flange / clamp	3/8 ... 2-1/2 thread	flange - M5
ORIFICE DIAMETER	1.4 ... 50 mm	1.5 ... 4 mm	5 ... 9 mm	5 ... 9 mm	-	13 ... 90 mm	12 ... 59 mm	0.8 ... 1.6 mm
Kv (l/min)	0.14 ... 45 (m ³ /h)	0.08 ... 28 (m ³ /h)	6.5 ... 23	6.5 ... 23	3.7	2.2 ... 132 (m ³ /h)	2.6 ... 65 (m ³ /h)	26 ... 80 l/min
PRESSURE RANGE	0 ÷ 0.8 ... 22 bar	0 ÷ 4 ... 25 bar	3 ÷ 6 bar 0 ÷ 6 bar	3 ÷ 6 bar 0 ÷ 6 bar	0 ÷ 10 bar	0 ÷ 2 ... 16 bar	0 ÷ 6 ... 20 bar	0 ÷ 4 ... 10 bar
TEMPERATURE RANGE	-10 ÷ 90 ... 140 °C	-10 ÷ 140 °C	0 ÷ 50 °C	0 ÷ 50 °C	-5 ÷ 50 °C	-10 ÷ 180 °C 25 ÷ 220 °C	-20 ÷ 130 °C	0 ÷ +60 °C
MEDIA	inert gas/liquid	inert gas/liquid	inert gas oxygen	inert gas oxygen	inert gas oxygen	inert gas/liquid steam	inert gas/liquid steam	inert gases, oxygen
SEALS	EPDM FKM NBR	EPDM FKM	FKM	FKM	FKM	PTFE	EPDM	NBR FKM EPDM
VOLTAGE	12 ... 24 VDC 24 ... 230 VAC	12 ... 24 VDC 24 ... 230 VAC	-	24 VDC	-	-	-	12-24 VDC
POWER CONSUMPTION	10 ... 30 W 12 ... 29 VA	19 W 15 VA	-	1.3/0.25 ... 2 W	-	-	-	3 W
DUTY CYCLE	ED 100%	ED 100%	-	ED 100%	-	-	-	ED 100%
ELECTRIC CONNECTION	connector	connector	-	connector	-	-	-	DIN 43650 8mm connector



	AP	CP16	CP20	K8P	OPEN FRAME	PRE	MX-PRO
COIL SIZE	22 mm	16 mm	20 mm	16 mm	22 mm	50x50 mm	70 mm
FUNCTION	2/2 PROPO NC	2/2 NC	2/2 NC	3/2 NC	2/2-way 3/3-way Parallel	3 NC - NO	3/2 NC
OPERATION	poppet	poppet	poppet	poppet	0-10 V or 4-20 mA IO-Link	0-10 V DC 4-20 mA digital 5 input I/O Link	membrane
PNEUMATIC CONNECTIONS	flange G1/8 - M5	cartridge	cartridge	flange	G1/8	1/4G 3/4G NPTF	G1/2
ORIFICE DIAMETER	1 ... 2.4 mm	1 ... 2 mm	3; 3,5 mm	0.5 mm	G1/8	-	
Kv (l/min)	33 ... 132 l/min	70 ... 90 l/min	145 ... 165 l/min	12 l/min (6 bar) 6 l/min (3 bar) 8 l/min (7 bar) 2 l/min (1 bar)	max 90 NI/min	1100 NI/min 4600 NI/min	0 ... 10 000 l/min
PRESSURE RANGE	0 ÷ 4 ... 10 bar	3; 5; 8 bar	2; 2,8 bar	0 ÷ 10 bar 0 ÷ 3 bar 0 ÷ 7 bar 0 ÷ 1 bar	-1 ÷ 10 bar	1; 4; 6; 7; 10,3 bar	0 ÷ 10 bar 0 ÷ 3 bar 0 ÷ 7 bar 0 ÷ 1 bar
TEMPERATURE RANGE	0 ÷ +60°C	10 ÷ +50°C	10 ÷ +50°C	0 ÷ +50°C	0 ÷ 60°C for low temperature on request	0 ÷ +50°C	0 ÷ 50°C
MEDIA	inert gases, oxygen	inert gases, oxygen	inert gases, oxygen	inert gases	compressed air, inert gases and oxygen Filtering according to ISO 8573-1 class 7.4.4	inert gases, oxygen	inert gases
SEALS	NBR FKM EPDM	FKM	FKM	NBR	NBR FKM EPDM	FKM	NBR
VOLTAGE	12-24 V DC	6-12-24 V DC	6-12-24 V DC	24 V DC (supply) 0-10 V DC (input) 4-20 mA (input)	24 VDC +/-10% or 12VDC +/- 5%	+24 V DC	19-28 V DC 0-1 V (input) 4-20 mA (input)
POWER CONSUMPTION	5 W	3,1 W	5; 3,7 W	1 W	0,3 A (Master module) 0,3 A (Slave module)	2 W	1 W
DUTY CYCLE	ED 100%	ED 100%	ED 100%	ED 100%	ED 100%	ED 100%	ED 100%
ELECTRIC CONNECTION	DIN 43650 (B Shape) connector	cables	cables	M8 4 Pin (male) connector	M12 5 Pin (male)	M12	M8 4 Pin (male) connector

BQF (Business Qualification Form)

BQF (BUSINESS QUALIFICATION FORMULAR)

BQF ▶ ACCOUNT _____ SALES REP _____

*Function n° Way 2/2 NO 2/2 NC 3/2 NO 3/2 NC

*Function direct servo membrane separate flow

*Actuation monostable bistable proportional

*Orifice size (mm) 1>2 2>3

*Connection Ports body/base m5 1/8 1/4 other flange

*Flow rate 1>2 2>3

Flow Factor (Kv) _____

*Pressure range (bar) min max working pressure back pressure

*Ambient temperature (°C) min max

*Media temperature (°C) min max

* Media _____

Water Hammer no yes

*Body material _____

*Seal material _____ static _____ dynamic

*Valve assembling single manifold

Coil assembling 0° 180°

*Manual override bistable monostable no

*Electrical connection (ex. Cable, pins, PCB etc) _____

Response time (msec) on/off off/on

*Coil voltage (Volt) 12 24 48 110 220
 other DC AC

Power consumption (Watt/VA) _____

Protection degree IP _____

Frequency (Hz) _____

*Approvals _____

* = mandatory data

NOTE:



Contacts

For further information about our products and conditions of sale, please contact the Camozzi Fluid Control department at:

Camozzi Automation S.p.A.

Società Unipersonale
Via Eritrea, 20/I
25126 Brescia
Italy
Tel. +39 030 37921

Customer Service

Tel. +39 030 3792790
service@camozzi.com

Export Department

Tel. +39 030 3792262
info@camozzi.com



Automation

