

Series GSCU, GMCU, GSVU, GMVU, GSCO, GMCO flow control valves

Unidirectional and bidirectional banjo flow controllers with nominal diameter 1,5 - 3,5 - 5 mm
Ports: M5, G1/8 and G1/4



These unidirectional and bidirectional flow controllers have been designed as small as possible to enable mounting directly on valves or cylinders. The flow regulation range is wide and gradual, allowing the regulation to be very accurate either at minimum or maximum flow.

GENERAL DATA

Construction	needle - type
Valve group	unidirectional and bidirectional controller
Materials	body and screws M5 inox; 1/8 - 1/4 - 3/8 - 1/2 OT58 seals NBR
Mounting	by male threaded
Installation	in any position
Operating temperature	0°C ÷ 80°C (with dry air -20°C)
Operating pressure	1 ÷ 10 bar
Nominal pressure	6 bar
Nominal flow	see graph
Nominal diameter	M5 = 1.5 mm - G1/8 = 2 mm - G1/4 = 4 mm G3/8 = 7 mm - G1/2 = 12 mm
Fluid	filtered air

CODING EXAMPLE

GM	CU		9	03	-	1/8	-	6																					
GM	ACTUATION: GM = manual GS = screwdriver																												
CU	ASSEMBLY: CU = on cylinders unidirectional VU = on valves unidirectional CO = bidirectional																												
9	VERSIONS: 8 = needle (screwdriver operated) 9 = needle (manually operated)																												
03	FLOW CONTROL RANGE: <table border="1"> <thead> <tr> <th></th> <th>size</th> <th>∅ tube</th> </tr> </thead> <tbody> <tr> <td>13 =</td> <td>1.5</td> <td>3</td> </tr> <tr> <td>14 =</td> <td>1.5</td> <td>4</td> </tr> <tr> <td>03 =</td> <td>3.5</td> <td>6</td> </tr> <tr> <td>04 =</td> <td>3.5</td> <td>8</td> </tr> <tr> <td>05 =</td> <td>5</td> <td>8</td> </tr> <tr> <td>06 =</td> <td>5</td> <td>10</td> </tr> </tbody> </table>									size	∅ tube	13 =	1.5	3	14 =	1.5	4	03 =	3.5	6	04 =	3.5	8	05 =	5	8	06 =	5	10
	size	∅ tube																											
13 =	1.5	3																											
14 =	1.5	4																											
03 =	3.5	6																											
04 =	3.5	8																											
05 =	5	8																											
06 =	5	10																											
1/8	PORTS: M5 1/8 1/4																												
6	∅ TUBE: 3 4 6 8 10																												

To ensure the right choice of unidirectional flow controller, proceed as follows: calculate the quantity of air in NI/min (see cylinder Table); determine the stroke time of the cylinder; refer to graph to see which controller is the right type.

UNIDIRECTIONAL AND BIDIRECTIONAL FLOW CONTROL REGULATORS

SERIES GSCU, GMCU, GSCO, GMCO VALVES

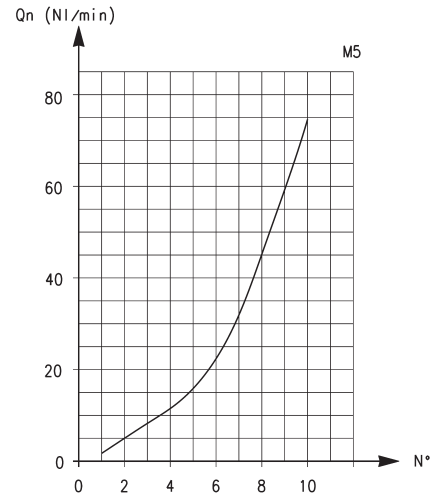

To ensure the right choice of unidirectional flow controller, proceed as follows: calculate the quantity of air in NL/min (see cylinder Table); determine the stroke time of the cylinder; refer to graph to see which controller is the right type. In the case of bidirectional regulators, refer to the graph and check whether the flow control range is suitable for the work required.

M5
Flow Qn (NL/min.) from 2 → 1 with controller OPEN: 70
Flow Qn (NL/min.) from 2 → 1 with controller CLOSED: 33

N° = number of screw turns
NB: Qn is determined with a supply pressure of 6 bar and with ΔP = 1 bar at the outlet.

UNIDIRECTIONAL AND BIDIRECTIONAL FLOW CONTROL REGULATORS

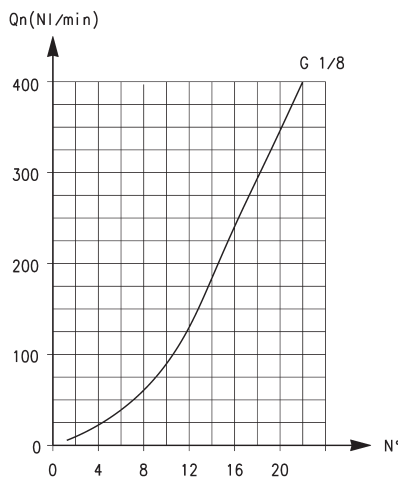

G1/8
Flow Qn (NL/min.) from 2 → 1 with controller OPEN: 440
Flow Qn (NL/min.) from 2 → 1 with controller CLOSED: 170

N° = number of screw turns
NB: Qn is determined with a supply pressure of 6 bar and with ΔP = 1 bar at the outlet.

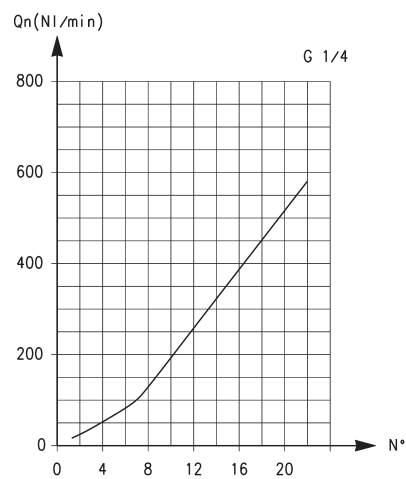

G1/4
Flow Qn (NL/min.) from 2 → 1 with controller OPEN: 790
Flow Qn (NL/min.) from 2 → 1 with controller CLOSED: 460

N° = number of screw turns
NB: Qn is determined with a supply pressure of 6 bar and with ΔP = 1 bar at the outlet.

Valves Series GSCU



Unidirectional flow controller for mounting on single-acting or double-acting cylinders.
Screwdriver adjustment.
Ports: M5, G1/8, G1/4.

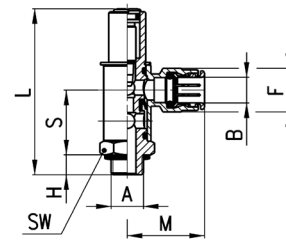

DIMENSIONS								
Mod.	A	B	S	H	L	M	F	SW
GSCU 813-M5-3	M5	3	12	3	27,5	12,5	6,5	8
GSCU 814-M5-4	M5	4	12	3	27,5	19	8,8	8
GSCU 803-1/8-6	G1/8	6	22,5	5	50	26,5	13	14
GSCU 804-1/8-8	G1/8	8	22,5	5	50	28	15	14
GSCU 805-1/4-8	G1/4	8	27	7	67,5	28,5	15	19
GSCU 806-1/4-10	G1/4	10	27	7	67,5	31	17,5	19

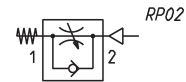

Valves Series GMCU



Unidirectional flow controller for mounting on single-acting or double-acting cylinders.
Knurled screw adjustment.
Ports: M5, G1/8, G1/4.

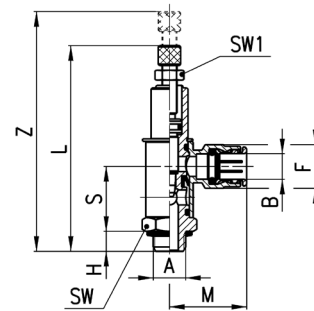

DIMENSIONS										
Mod.	A	B	S	H	L	Z	M	F	SW	SW1
GMCU 913-M5-3	M5	3	12	3	37	42,5	12,5	6,5	8	5,5
GMCU 914-M5-4	M5	4	12	3	37	42,5	19	8,8	8	5,5
GMCU 903-1/8-6	G1/8	6	22,5	5	65,5	72,5	26,5	13	14	7
GMCU 904-1/8-8	G1/8	8	22,5	5	65,5	72,5	28	15	14	7
GMCU 905-1/4-8	G1/4	8	27	7	85	97,5	28,5	15	19	10
GMCU 906-1/4-10	G1/4	10	27	7	85	97,5	31	17,5	19	10

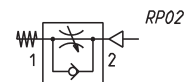

Valves Series GSVU



Unidirectional flow controller for mounting on valves.
Screwdriver adjustment.
Ports: M5, G1/8, G1/4.

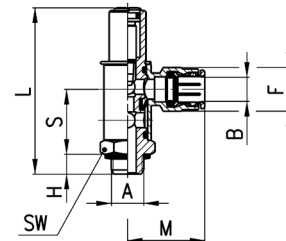

DIMENSIONS								
Mod.	A	B	S	H	L	M	F	SW
GSVU 813-M5-3	M5	3	12	3	27,5	12,5	6,5	8
GSVU 814-M5-4	M5	4	12	3	27,5	19	8,8	8
GSVU 803-1/8-6	G1/8	6	22,5	5	50	26,5	13	14
GSVU 804-1/8-8	G1/8	8	22,5	5	50	28	15	14
GSVU 805-1/4-8	G1/4	8	27	7	67,5	28,5	15	19
GSVU 806-1/4-10	G1/4	10	27	7	67,5	31	17,5	19

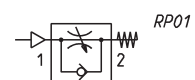

Valves Series GMVU



Unidirectional flow controller for mounting on valve.
Adjustment of setting by a manually operated knurled screw.
Ports: M5, G1/8, G1/4.

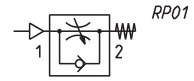
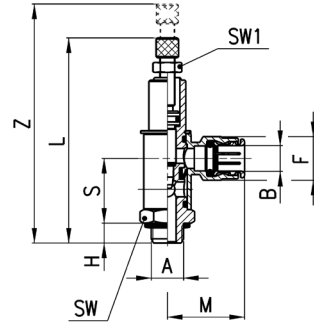

DIMENSIONS										
Mod.	A	B	S	H	L	Z	M	F	SW	SW1
GMVU 913-M5-3	M5	3	12	3	37	42,5	12,5	6,5	8	5,5
GMVU 914-M5-4	M5	4	12	3	37	42,5	19	8,8	8	5,5
GMVU 903-1/8-6	G1/8	6	22,5	5	50	72,5	26	13	14	7
GMVU 904-1/8-8	G1/8	8	22,5	5	50	72,5	28	15	14	7
GMVU 905-1/4-8	G1/4	8	27	7	67,5	97,5	29	15	19	10
GMVU 906-1/4-10	G1/4	10	27	7	67,5	97,5	31	17,5	19	10

Valves Series GSCO



Bidirectional flow controller.
Screwdriver adjustment.
Ports: M5, G1/8, G1/4.

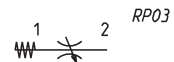
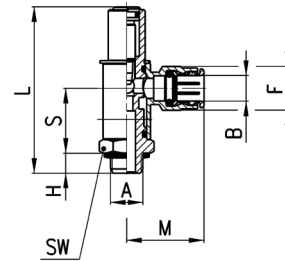

DIMENSIONS									
Mod.	A	B	S	H	L	M	F	SW	
GSCO 813-M5-3	M5	3	12	3	27,5	12,5	6,5	8	
GSCO 814-M5-4	M5	4	12	3	27,5	19	8,8	8	
GSCO 803-1/8-6	G1/8	6	22,5	5	50	26,5	13	14	
GSCO 804-1/8-8	G1/8	8	22,5	5	50	28	15	14	
GSCO 805-1/4-8	G1/4	8	27	7	67,5	28,5	15	19	
GSCO 806-1/4-10	G1/4	10	27	7	67,5	31	17,5	19	

Valves Series GMCO



Bidirectional flow controller.
Adjustment of setting by a manually operated knurled screw.
Ports: M5, G1/8, G1/4.

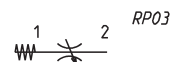
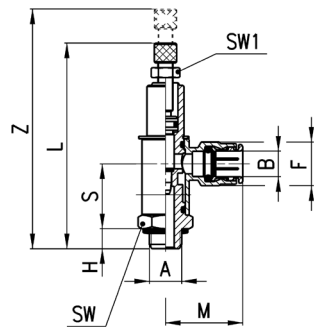

DIMENSIONS										
Mod.	A	B	S	H	L	Z	M	F	SW	SW1
GMCO 913-M5-3	M5	3	12	3	37	42,5	12,5	6,5	8	5,5
GMCO 914-M5-4	M5	4	12	3	37	42,5	19	8,8	8	5,5
GMCO 903-1/8-6	G1/8	6	22,5	5	65,5	72,5	26,5	13	14	7
GMCO 904-1/8-8	G1/8	8	22,5	5	65,5	72,5	28	15	14	7
GMCO 905-1/4-8	G1/4	8	27	7	85	97,5	28,5	15	19	10
GMCO 906-1/4-10	G1/4	10	27	7	85	97,5	31	17,5	19	10