

Valve islands Cabinet Version Series HC

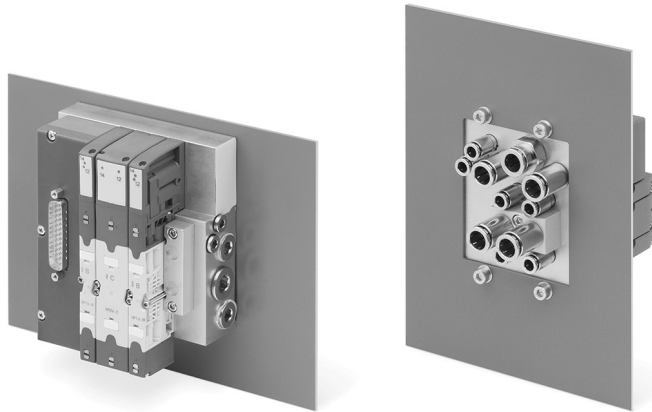

Multipole connection with 25 or 37 pins
Valve functions: 2x2/2, 2x3/2, 5/2, 5/3 CC



- » Valve flow: 400 and 700 NL/min
- » Subbases: from 4 to 32 positions for valve size 10.5mm, from 2 to 16 positions for valve size 21mm
- » Same subbase for both sizes
- » Rear pneumatic outlets
- » Interface seal with the internal part of the Cabinet

In applications which are subject to washing or operate in particularly dirty environments, having a specific solution represents a distinct advantage. With the Series HC it is possible to exploit the subbase and relative perimetric seal to close the passage window of all tubings. In this way the external environment is isolated from the internal part of the cabinet, guaranteeing a high protection level against solid and liquid particles that, upon entering, may damage the components.

All pneumatic connections are immediately available avoiding operations for the installation of panel mount fittings. Series HC uses the same valve functions as those available in Series HN.

Thanks to a particularly flexible use of the valve positions, different configurations can be realized (further details can be found on the following pages regarding the correct management of electrical signals).

GENERAL DATA

SERIES HC VALVE ISLANDS

PNEUMATIC SECTION	
Valve construction	spool with seals
Valve functions	5/2 monostable and bistable 5/3 CC 2x2/2 NO 2x2/2 NC 1x2/2 NC + 1xNO 2x3/2 NC 2x3/2 NO 1x3/2 NC + 1x3/2 NO
Materials	spool in aluminium spool seals in HNBR other seals in NBR cartridges in brass body and end covers in technopolymer subbases in aluminium
Connections	Inlets 2 and 4, size 10.5mm: M7, tube Ø 4, tube Ø 6 Inlets 2 and 4, size 21mm: G1/4, tube Ø 6, tube Ø 8, tube Ø 10 Supply 1: G3/8, tube Ø 8, tube Ø 10, tube Ø 12 Supply 12/14: M7, tube Ø 6 (6512 6-M7-M) Exhausts 3 and 5: G1/4, tube Ø 10 (6512 10-1/4-M) Exhausts 82/84: M7, silencer (2931 M7)
Temperature	0 ÷ 50°C
Air specifications	Filtered compressed air, non lubricated, class [6:4:4] according to ISO 8573-1:2010. If lubrication is necessary, please only use oils with maximum viscosity of 32 Cst and the version with external servo-pilot supply. The servo-pilot supply air quality class must be [6:4:4] according to ISO 8573-1:2010 (do not lubricate).
Valve sizes	10.5mm 21mm
Working pressure	-0.9 ÷ 10 bar
Pilot pressure	3 ÷ 7 bar 4.5 ÷ 7 bar (with working pressure exceeding 6 bar for the versions 2x2/2 and 2x3/2)
Flow rate	400 NL/min (10.5mm) 700 NL/min (21mm)
Mounting position	any position
Protection class	IP 65
ELECTRICAL SECTION	
Type of Sub-D connector	25 or 37 pins
Max. absorption	0.8 A (with Sub-D connector 25 pins) 1 A (with Sub-D connector 37 pins)
Supply voltage	24 V DC +/-10%
Max. number of coils to operate	Size 10.5mm: 24 coils on 12 valve positions (with Sub-D connector 25 pins) 32 coils on 32 valve positions (with Sub-D connector 37 pins) Size 21mm: 24 coils on 6 valve positions (with Sub-D connector 25 pins) 32 coils on 16 valve positions (with Sub-D connector 37 pins) Sizes 10.5 mm and 21 mm simultaneously (further details can be found on the following pages the correct management of electrical signals)
Valve signalling	yellow led

MULTIPOLE VERSION and MULTIPOLE WITH SUB-D ADAPTOR VERSION

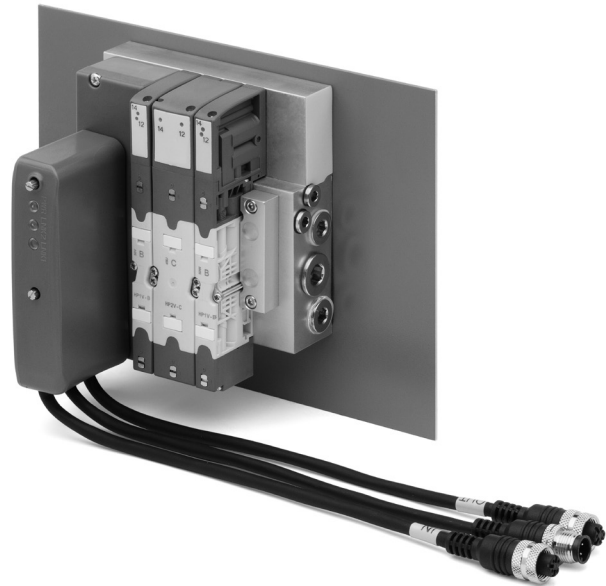
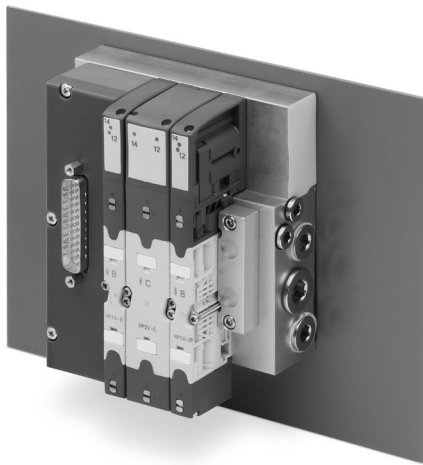

The Series HC can be connected in a quick and secure way thanks to the multipole electrical connection and to the pre-wired cable with 25 or 37 pins with in-line or angular connection.

The multipole valve island can be integrated in a serial structure managed by the Series CX multi-serial module.

SERIES HC VALVE ISLANDS

SUBBASE CHARACTERISTICS

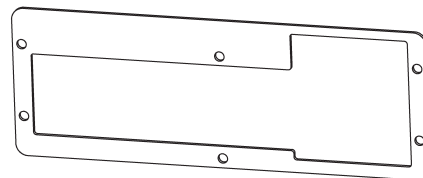
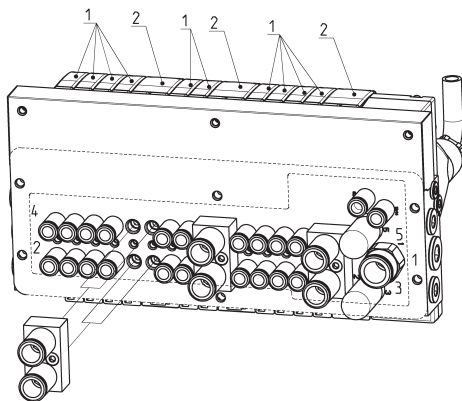

All the pneumatic connections are available on the lower side. The Series HC subbase has all the outlets for valves size 1. To use the major flow of valve size 2, a specific interface is used which joints the two outlets "2" and "4" of size 1 together into a single outlet "2" and "4" of size 2. This allows to use the same subbase regardless of valve size.

A specific seal can be placed on this side, thus allowing to isolate the internal part of the Cabinet as well as the components inside from the external environment. The solution is particularly useful in presence of liquid substances, as for example in the Food & Beverage sector and in the process industry. The valves can be placed as desired in any position. In case it is necessary to optimize the electric signals, we would recommend initially installing valves size 1 with two solenoids.

CODING EXAMPLE - MULTIPOLE VERSION

HC 5 H - 03A - T4GTGST3G - M2B2CBMZV3M - G - G

SERIES HC VALVE ISLANDS

HC	SERIES		
5	SIZE: 1 = 10.5 2 = 21 5 = Mixed		
H	ELECTRICAL CONNECTION: M = Multipole 25 pin PNP H = Multipole 37 pin PNP		
03A	CONNECTION: 000 = without connector/cable	CONNECTOR WITH CABLE AXIAL OUTPUT: 03A = 3m 05A = 5m 10A = 10m 15A = 15m 20A = 20m 25A = 25m CONNECTOR WITH CABLE RADIAL OUTPUT: 03R = 3m 05R = 5m 10R = 10m 15R = 15m 20R = 20m 25R = 25m	CONNECTOR WITHOUT CABLE: 4XA = 25 pins axial 4XR = 25 pins radial 9XA = 37 pins axial 9XR = 37 pins radial
T4GTGST3G	VALVE DIMENSION AND TYPE OF CONNECTION: Size 1 F = M7 threads G = with fittings for tube ø 4 L = with fittings for tube ø 6	Size 2 M = G1/4 threads N = with fittings for tube ø 6 P = with fittings for tube ø 8 T = with fittings for tube ø 10 S = silencers for Z plate	
M2B2CBMZV3M	SOLENOID VALVES Size 1 and 2: M = 5/2 Monostable B = 5/2 Bistable V = 5/3 CC C = 2x3/2 NC A = 2x3/2 NO G = 1x3/2 NC + 1x3/2 NO E = 2x2/2 NC F = 2x2/2 NO I = 1x2/2 NC + 1x2/2 NO L = free position	SOLENOID VALVE + PRESSURE REGULATOR on channel 1, Size 2: N = 5/2 Monostable P = 5/2 Bistable Q = 5/3 CC R = 2x3/2 NC S = 2x3/2 NO T = 1x3/2 NC + 1x3/2 NO U = 2x2/2 NC X = 2x2/2 NO Y = 1x2/2 NC + 1x2/2 NO	PLATES: Z = plate for supplementary exhaust K = plate for supplementary supply
G	CONNECTIONS: Internal servo-pilot Internal servo-pilot and silencers External servo-pilot External servo-pilot and silencers If the connection on the right side only, add X at the end of the code. For example: GX (Internal servo-pilot, silencers, fitting tube ø 8) The connections on the sides that are not used are equipped with closing taps.	Supply fitting (1) Thread ø 8 ø 10 ø 12 A E I P - G M R B F L Q - H N S Fitting ø 10 on exhausts 3/5 Fitting ø 6 on servo-pilot 12/14 Silencer on 82/84 If the connection on the left side only, add K at the end of the code. For example: GK A and B versions are equipped with taps on the left side and on the right one.	If the connection is on both sides, add W at the end of the code. For example: GW
	ACCESSORIES G = Interface Seal = no seal interface		

In presence of identical consequent codes both for the subbases as for the valves you need to substitute the letter with the number.
Ex: HC5H-03A-TGGGGTGSTGGG-MBBCCBMZVMMM-G is converted to HHC5H-03A-T4GTGST3G-M2B2CBMZV3M-G.

CODING - MULTIPOLE VERSION

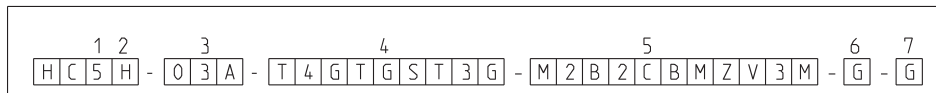
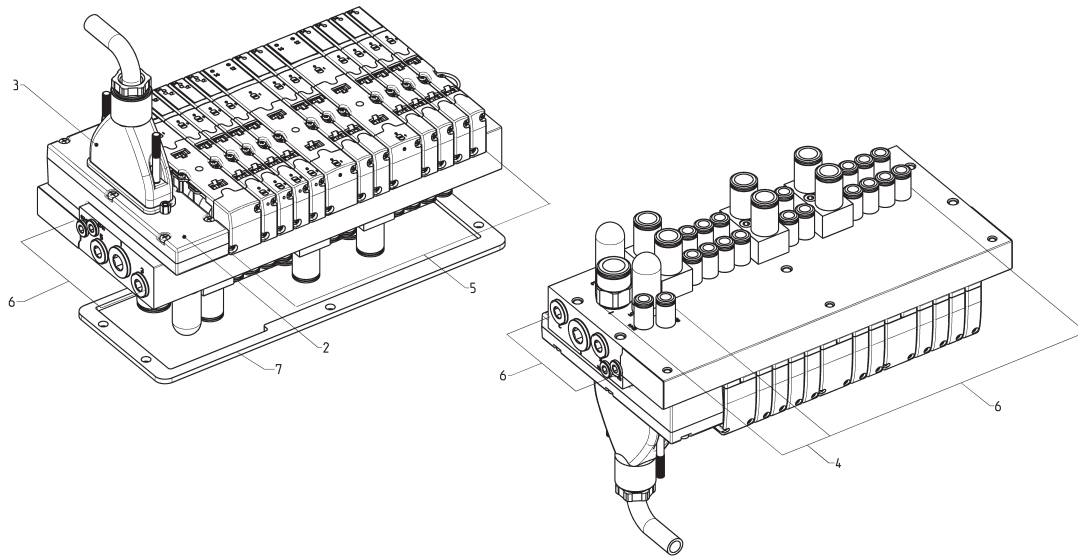

HC...						
SIZE (1)	ELECTRICAL CONNECTION (2)	CONNECTION (3)	VALVE DIMENSION and CONNECTION Size 1 (4)	SOLENOID VALVES Size 1 and 2 (5)	CONNECTIONS / SERVO PILOT Threaded (low side) (6)	ACCESSORIES (7)
1	M	000	F	M	A	G
2	H	03A	G	B	B	
5		05A	L	V	CONNECTIONS / SERVO PILOT Fittings tube Ø 8 (low side)	
		10A	VALVE DIMENSION and CONNECTION Size 2	C	E	
		15A	M	A	F	
		20A	N	G	G	
		25A	P	E	H	
		03R	T	F	CONNECTIONS / SERVO PILOT Fittings tube Ø 10 (low side)	
		05R	S	I	I	
		10R		L	L	
		15R		SOLENOID VALVE + PRESSURE REGULATOR channel 1, size 2	M	
		20R		N	N	
		25R		P	CONNECTIONS / SERVO PILOT Fittings tube Ø 12 (supply)	
		4XA		Q	P	
		4XR		R	Q	
		9XA		S	R	
		9XR		T	S	
		CXA		U	See the notes at the end of the coding example	
				X		
				Y		
				PLATES		
				Z		
				K		

MULTIPOLE version - COMPONENTS

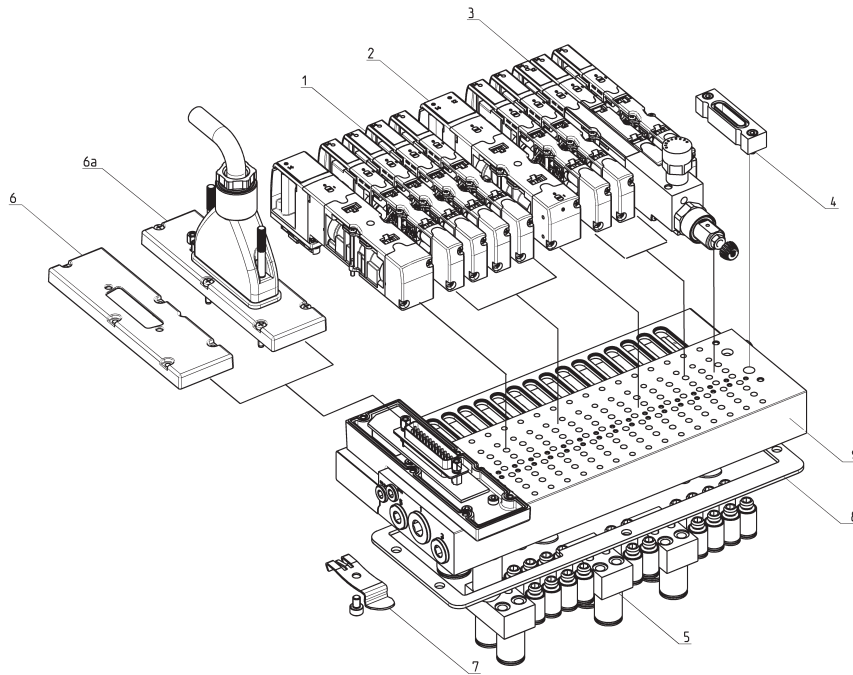

COMPONENTS

1	Solenoid valve size 1 (10.5 mm)
2	Solenoid valve size 2 (21 mm)
3	Valve size 2 with pressure regulator
4	Plate for internal/external servo pilot
5	Outlet interface for valves size 2
6	Multipole electric cover 25 pins
6a	Multipole electric cover 37 pins
7	Mounting bracket for DIN rail
8	Interface seal
9	Subbase

AVAILABLE FUNCTION - SYMBOLS FOR SOLENOID VALVES

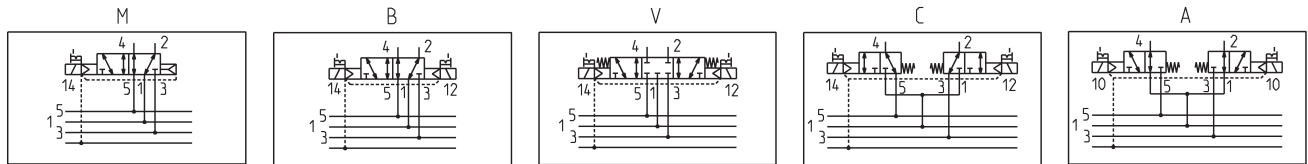

M = 5/2-way, Monostable

B = 5/2-way, Bistable

V = 5/3-way Centres Closed

C = 2 x 3/2-way NC

A = 2 x 3/2-way NO

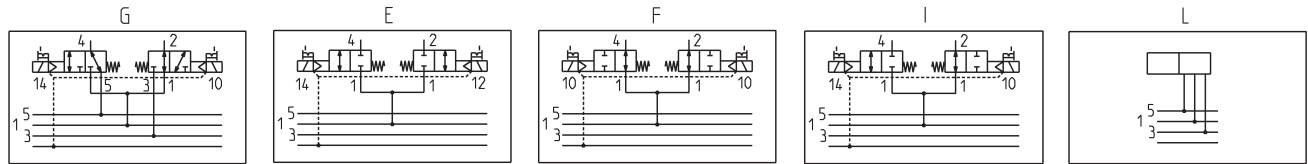

G = 1 x 3/2-way NC + 1 x 3/2-way NO

E = 2 x 2/2-way NC

F = 2 x 2/2-way NO

I = 1 x 2/2-way NC + 1 x 2/2-way NO

L = free position

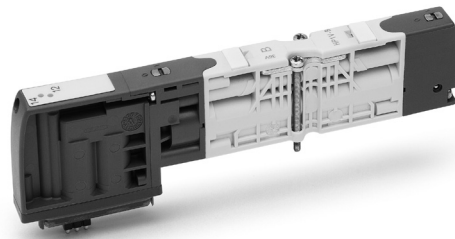

AVAILABLE FUNCTIONS - SYMBOLS FOR SOLENOID VALVES WITH PRESSURE REGULATOR

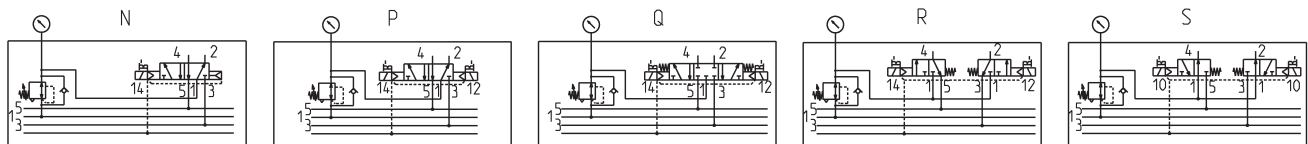

N = 5/2-way, Monostable

P = 5/2-way, Bistable

Q = 5/3-way Centres Closed

R = 2 x 3/2-way NC

S = 2 x 3/2-way NO

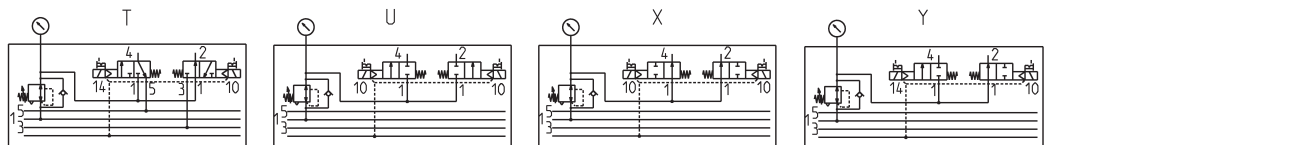

T = 1 x 3/2-way NC + 1 x 3/2-way NO

U = 2 x 2/2-way NC

X = 2 x 2/2-way NO

Y = 1 x 2/2-way NC + 1 x 2/2-way NO

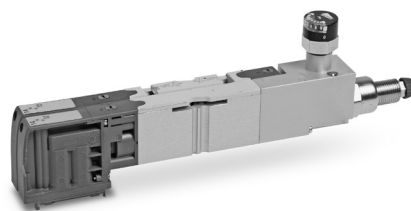

CORRECT MANAGEMENT OF ELECTRICAL SIGNALS - SIZE 10.5mm

- = (A)
- = (B)
- ⊗ = (C)

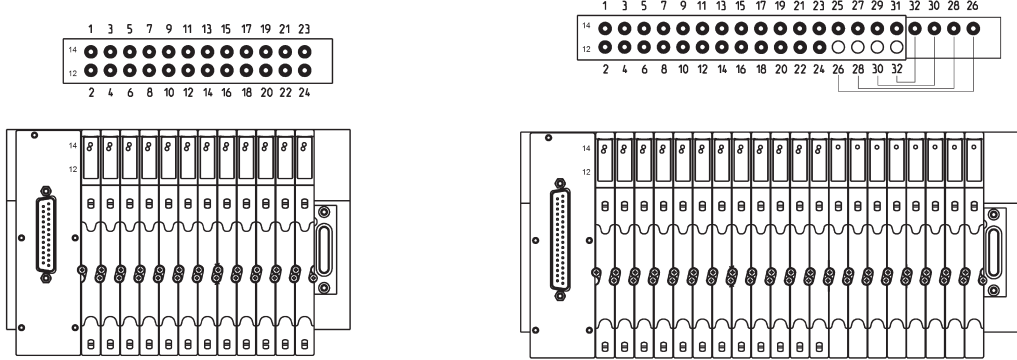

- A = free pin
- B = pin used to control the solenoid
- C = pin not usable
- 12 14 = solenoid position

25-pin connector: 24 signals usable and available on a max of 12 valve positions size 1. The 12 pos. can be freely configured between size 1 and 2, valves size 2 occupy 2 pos. size 1.

37-pin connector: 32 signals can be freely used up to a max of 16 valve positions, bistable or monostable size 1. To make the best of electrical signals, it is necessary to use valves with two solenoids in the first positions. Signals that are not necessary to control the solenoids are not lost but can be used on the internal expansion board (see pins 32/30/28/26 in the above example).

CORRECT MANAGEMENT OF ELECTRICAL SIGNALS - SIZE 21mm

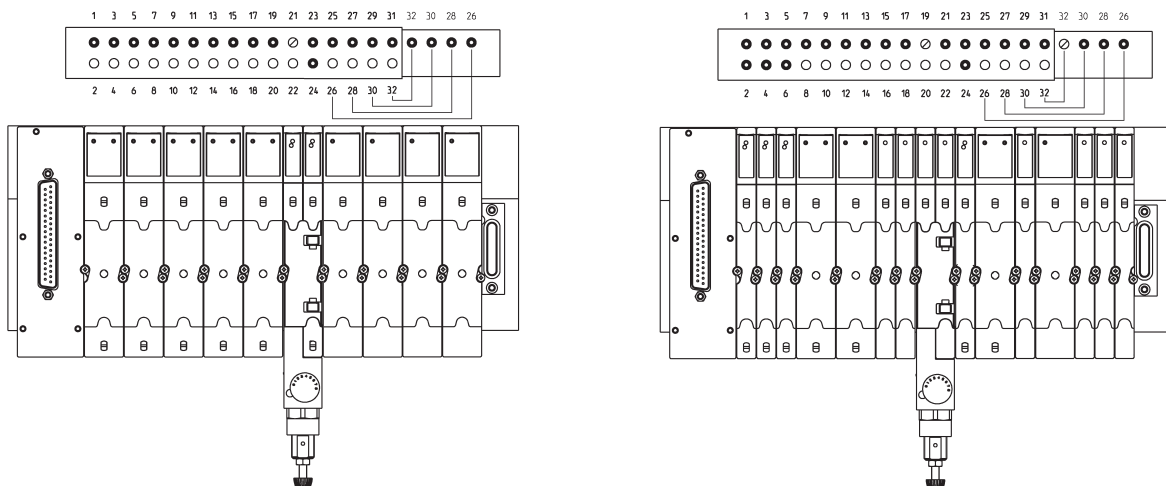

The valve size 2 doesn't need commands with even numbers (of pins) placed in the lower part of the board. These can be used in the expansion board, thus allowing the realization of valve islands consisting of up to 16 valves.

In case the valves with 2 solenoids are not included in the initial positions, the expansion possibility is reduced. In the example, the signals before pin 26 cannot be used in the expansion board.

37-pin connector: with valves size 2, 32 signals can be used up to a max of 16 valve positions, bistable or monostable.

Valve with integrated pressure regulator HP2V-...

This solution has the advantage of reducing the valve island's overall height compared to traditional "sandwich" solutions. The pressure regulator allows to set the supply pressure of the lateral valve.

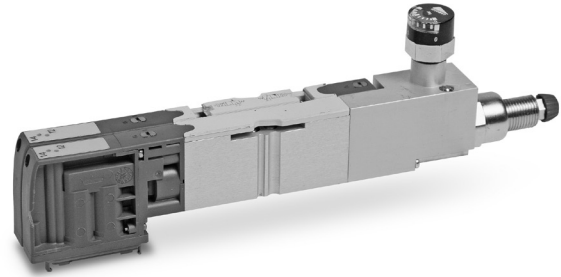

SIZE AND SHAPE OF THE PASSAGE WINDOW

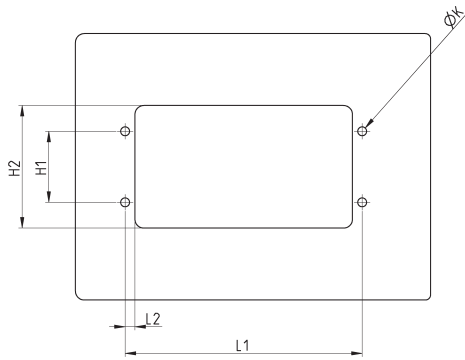

VALVE ISLANDS FROM 4 TO 8 PLACES

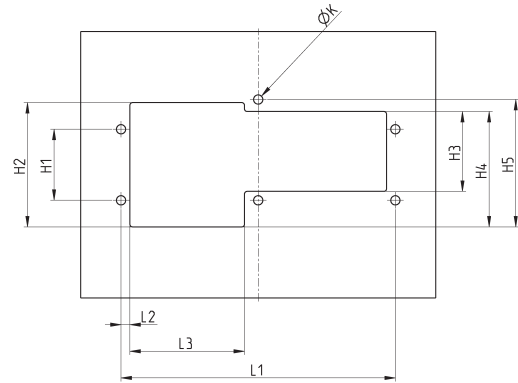

VALVE ISLANDS FROM 10 TO 16 PLACES

Nr of PLACES	H1	H2	L1	L2	ØK	Nr of PLACES	H1	H2	H3	H4	H5	L1	L2	L3	ØK
4	40	70	91.5	5	5	10	40	70	45	65	71.7	154.5	5	64.5	5
6	40	70	112.5	5	5	12	40	70	45	65	71.7	175.5	5	64.5	5
8	40	70	133.5	5	5	14	40	70	45	65	71.7	196.5	5	64.5	5
						16	40	70	45	65	71.7	217.2	5	64.5	5

Nr of PLACES		Nr of PLACES	
4	HCA1G-4	16	HCA1G-16
6	HCA1G-6	20	HCA1G-20
8	HCA1G-8	22	HCA1G-22
10	HCA1G-10	24	HCA1G-24
12	HCA1G-12	28	HCA1G-28
14	HCA1G-14	32	HCA1G-32

MULTIPOLE version 25 and 37 pin - DIMENSIONS

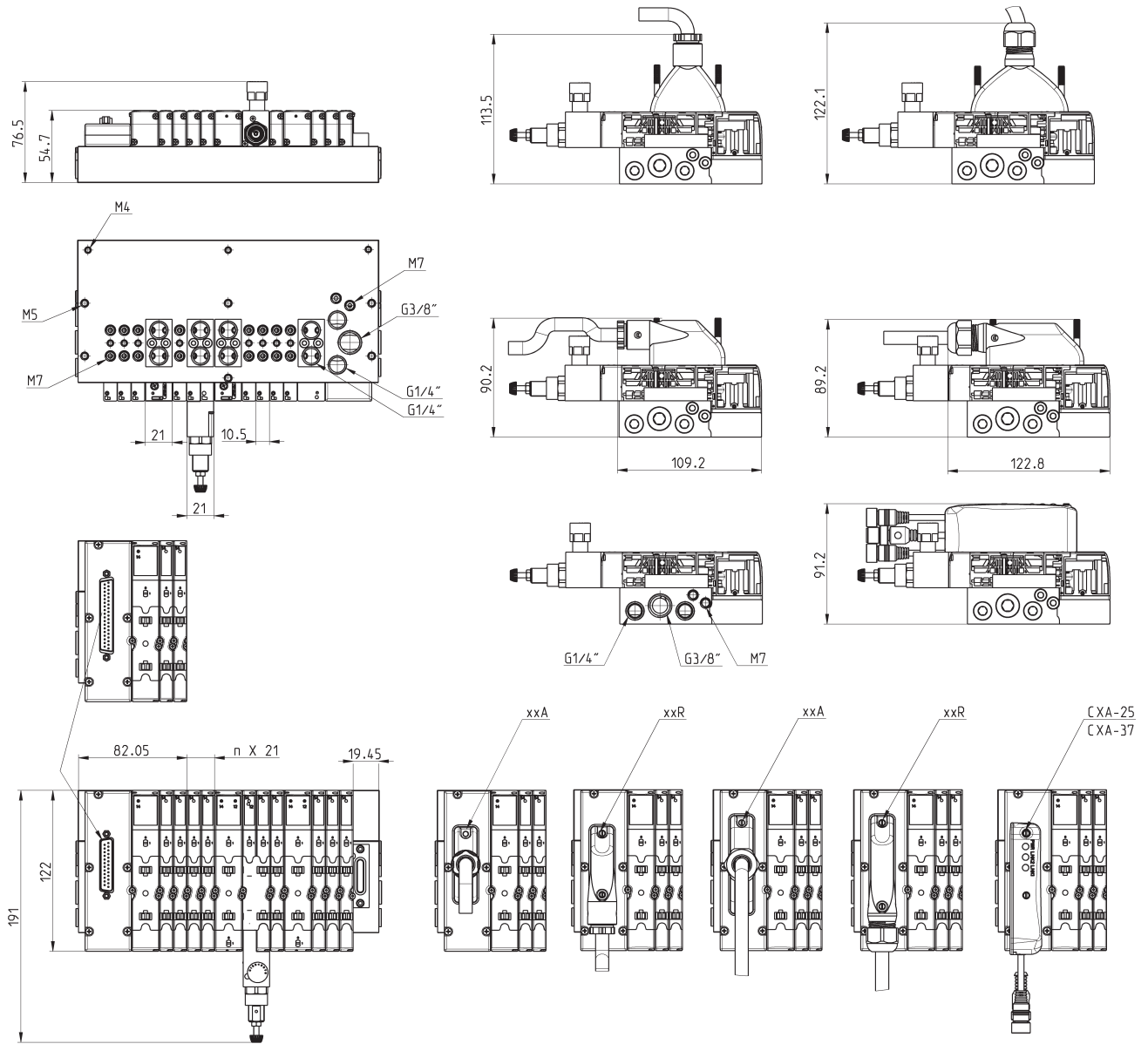

CODING EXAMPLE OF SINGLE VALVE (Spare part)

H	P	1	V	-	M
----------	----------	----------	----------	----------	----------

H	SERIES				
P	TYPE: P = pneumatic				
1	SIZE: 1 = 10,5 2 = 21				
V	TYPE OF ACCESSORY: V = Solenoid valve				
M	SOLENOID VALVE: M = 5/2 Monostable B = 5/2 Bistable V = 5/3 Centres Closed C = 2 x 3/2 NC A = 2 x 3/2 NO G = 1 x 3/2 NC + 1 x 3/2 NO E = 2 x 2/2 NC F = 2 x 2/2 NO I = 1 x 2/2 NC + 1 x 2/2 NO L = free position		SOLENOID VALVE + REGULATOR + SUBBASE N = 5/2 Monostable P = 5/2 Bistable Q = 5/3 Centres Closed R = 2 x 3/2 NC S = 2 x 3/2 NO T = 1 x 3/2 NC + 1 x 3/2 NO U = 2 x 2/2 NC X = 2 x 2/2 NO Y = 1 x 2/2 NC + 1 x 2/2 NO		

SERIES HC VALVE ISLANDS

CODING EXAMPLE OF SUBBASES - Accessories

HC	A	1	R	-	10
-----------	----------	----------	----------	----------	-----------

HC	SERIES				
A	TYPE: A = accessories				
1	SIZE: 1 = 10,5				
R	TYPE OF ACCESSORY: R = subbase for multipole connection G = seal				
10	VALVE POSITIONS: 4 = 4 6 = 6 8 = 8 10 = 10 12 = 12 14 = 14 16 = 16 20 = 20 24 = 24 28 = 28 32 = 32				

Interface for valve outlets size 10.5mm

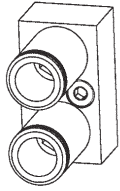

Interface for junction 2 M7 outputs in a single output 1/4

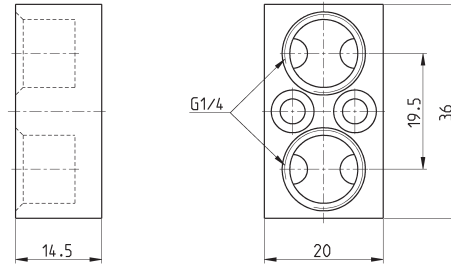

Supplied with:
1x interface
2x M4 screws
4x O-rings

Mod.
HC-M7-1/4

Plate for supplementary supply

It enables to integrate the supply. It uses two valve positions and allows, through the HC-M7-1/4 interface for the valve outlets, to integrate the air flow in the supply 1 channel.

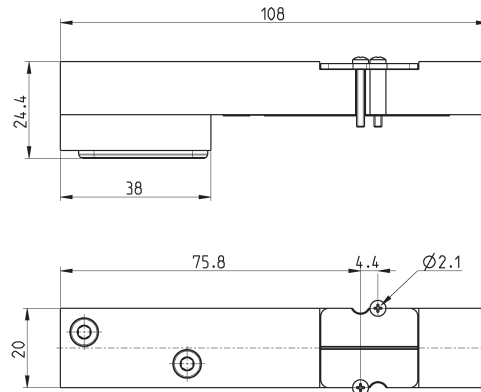

Supplied with:
1x plate
1x interface HC-M7-1/4

Mod.
HC-K-1/4

Plate for supplementary exhaust

It improves the flow characteristics of the exhaust. It is positioned on the sub-base, uses two valve positions and enables to increase the quantity of exhaust air, while keeping unchanged the aesthetics on the valve side. Also in Cabinet applications, it allows not to supply air into the protected area.

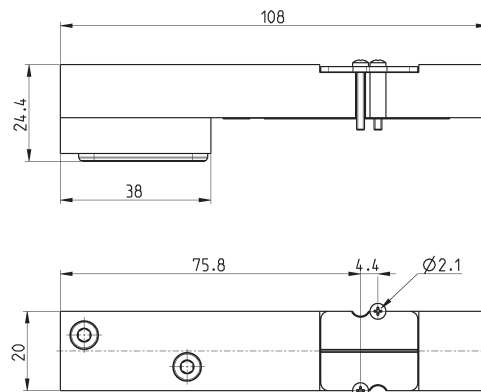

Supplied with:
1x plate
4x silencers 2931 M7

Mod.
HC-4Z-M7

Sub-D adaptor module 25 and 37 pin Mod. CXA-25P and CXA-37P



Led 1 = Yellow LNK1
Led 2 = Yellow LNK2
Led 3 = Green PWR, supply present and OK

It is an Expansion module of the subnet and can be connected to all valve islands with Sub-D connection. In the 25 pin version, it can manage up to a maximum of 24 outputs, while with 37 pin version, the outputs become 32. It has its own M12 A 4 pin male connection for the supply of the valves connected, distinguishing both logic supply and power supply and two M12 D 4 pin female connections for the Bus-IN and Bus-OUT of the subnet. The subnet can have a length of maximum 100 metres. The power of a single Output is 3 W to 24 V DC. Thanks to the PWM technique it is possible to set a power reduction to only maintain operation.

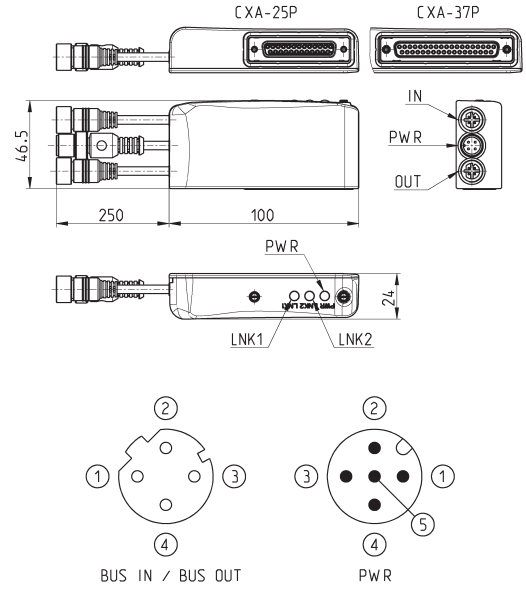

Mod.	Interface	Digital Outs	Bus-IN connection	Bus-OUT connection	PWR connection	Supply	Power for every Output
CXA-25P	Sub-D 25 pin	24	M12D 4 pin female	M12D 4 pin female	M12A 4 pin male	24 V DC	3 W
CXA-37P	Sub-D 37 pin	32	M12D 4 pin female	M12D 4 pin female	M12A 4 pin male	24 V DC	3 W

Straight Sub-D 25 pin female connector with axial cable

Protection class IP65

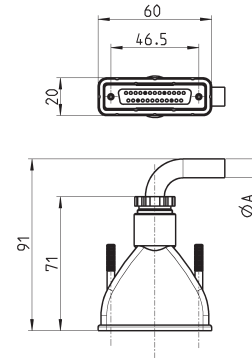

Mod.	mA	PIN	cable length (m)
G3X-3	7.7	16	3
G3X-5	7.7	16	5
G3X-10	7.7	16	10
G3X-15	7.7	16	15
G3X-20	7.7	16	20
G3X-25	7.7	16	25
G4X-3	9	25	3
G4X-5	9	25	5
G4X-10	9	25	10
G4X-15	9	25	15
G4X-20	9	25	20

Straight Sub-D 37 pin female connector with axial cable



Protection class IP65

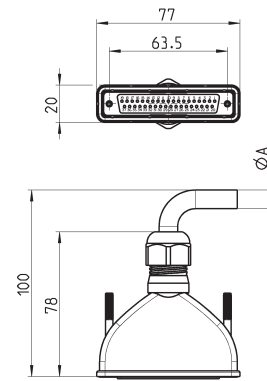

Mod.	$\varnothing A$	PIN	cable length (m)
G9X-3	12	37	3
G9X-5	12	37	5
G9X-10	12	37	10
G9X-15	12	37	15
G9X-20	12	37	20
G9X-25	12	37	25

Right angle Sub-D 37 pin female connector with radial cable



Protection class IP65

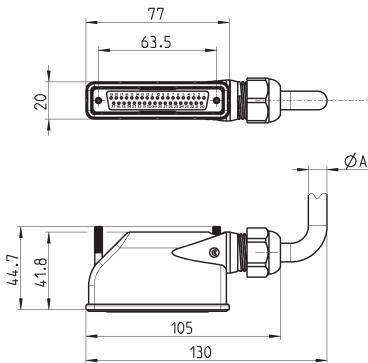

Mod.	$\varnothing A$	PIN	cable length (m)
G9X1-3	12	37	3
G9X1-5	12	37	5
G9X1-10	12	37	10
G9X1-15	12	37	15
G9X1-20	12	37	20
G9X1-25	12	37	25

Adapter cable, M8 3-pin male - M12 4-pin female



Protection class: IP69K

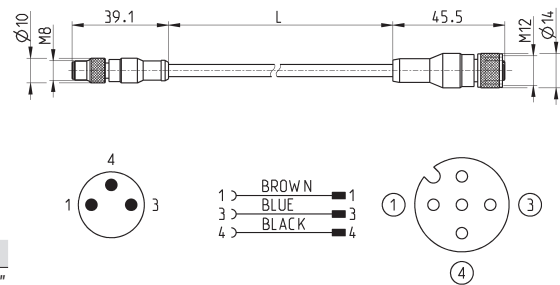

Mod.	description	max voltage	max current	Nr conn. wires	connections	outer sheath	cable "L" (m)
CS-AG03HB-C250	3-pin cable 24 AWG, high flexibility	50V AC / 60V DC	3 A	3	M8 3-pin male - M12 4-pin fem.	PUR black	2.5
CS-AG03HB-C500	3-pin cable 24 AWG, high flexibility	50V AC / 60V DC	3 A	3	M8 3-pin male - M12 4-pin fem.	PUR black	5