

Cilindri Compatti magnetici Serie 32

Semplice e doppio effetto, antirotazione
 ø 20, 25, 32, 40, 50, 63, 80, 100 mm

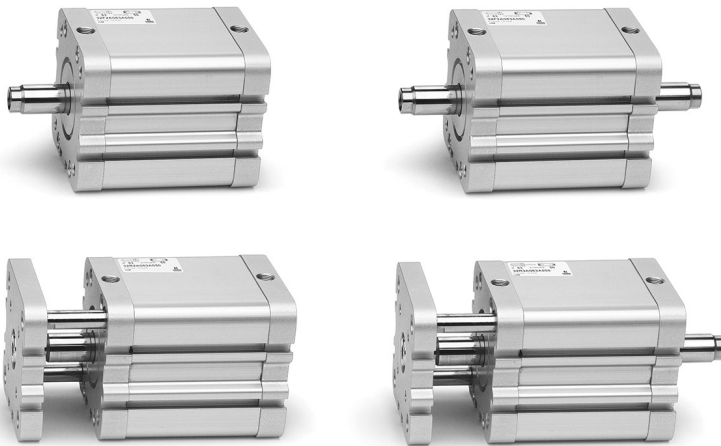

- » Conformi alla normativa ISO 21287
- » Design Compatto
- » Ampia gamma di modelli disponibili in vari diametri

I cilindri Serie 32, grazie alla loro estrema compattezza, sono adatti per l'installazione in spazi contenuti.
 Conformi alla normativa ISO 21287, consentono un grande vantaggio nell'uso di fissaggi identici ad altre serie di cilindri ISO15552.

CARATTERISTICHE GENERALI

Tipo di costruzione	a profilo compatto
Funzionamento	semplice e doppio effetto magnetico
Design	ISO 21287
Materiali	Testate e profilo in alluminio anodizzato - stelo inox AISI 303 rullato pistone in alluminio anodizzato - guarnizione stelo - or testata e guarnizione pistone in pu alte temperature guarnizione stelo - or testata e pistone in FKM (140°)
Fissaggio	con fori filettati sulle testate flangia - piedini - cerniere
Corse min. e max. (1)	Serie 32F,32M,32R Ø20-25=5-300mm Serie 32F,32M,32R Ø32-40-50-63=5-400mm Serie 32F,32M,32R Ø80-100=5-500mm
Temperatura d'esercizio	0°C ÷ 80°C (con aria secca -20°C)
Pressione d'esercizio	1 ÷ 10 bar (doppio effetto) 2 ÷ 10 bar (semplice effetto)
Fluido	Aria filtrata senza lubrificazione nel caso si utilizzasse aria lubrificata, si consiglia olio ISOVG32 e di non interrompere mai la lubrificazione.
Velocità d'esercizio	10 ÷ 1000 mm\sec (senza carico)

(1) = la corsa minima per l'utilizzo dei sensori è di 10 mm.

TABELLA CORSE STANDARD PER CILINDRI SERIE 32

✕ = Antirotazione; ● = Doppio effetto maschio/femmina;
■ = Semplice effetto molla ant./post. maschio/femmina.

CORSE STANDARD										
Ø	5	10	15	20	25	30	40	50	60	80
20	✕ ● ■	✕ ● ■	✕ ● ■	✕ ● ■	✕ ● ■	✕ ●	✕ ●	✕ ●		
25	✕ ● ■	✕ ● ■	✕ ● ■	✕ ● ■	✕ ● ■	✕ ●	✕ ●	✕ ●		
32	✕ ● ■	✕ ● ■	✕ ● ■	✕ ● ■	✕ ● ■	✕ ●	✕ ●	✕ ●	✕ ●	✕ ●
40	✕ ● ■	✕ ● ■	✕ ● ■	✕ ● ■	✕ ● ■	✕ ●	✕ ●	✕ ●	✕ ●	✕ ●
50		✕ ● ■	✕ ● ■	✕ ● ■	✕ ● ■	✕ ●	✕ ●	✕ ●	✕ ●	✕ ●
63		✕ ● ■	✕ ● ■	✕ ● ■	✕ ● ■	✕ ●	✕ ●	✕ ●	✕ ●	✕ ●
80		✕ ● ■	✕ ● ■	✕ ● ■	✕ ● ■	✕ ●	✕ ●	✕ ●	✕ ●	✕ ●
100		✕ ● ■	✕ ● ■	✕ ● ■	✕ ● ■	✕ ●	✕ ●	✕ ●	✕ ●	✕ ●

ESEMPIO DI CODIFICA

32	M	2	A	032	A	050	
-----------	----------	----------	----------	------------	----------	------------	--

32	SERIE	
M	VERSIONE M = filetto stelo maschio, montato con dado stelo Mod. U F = filetto stelo femmina R = antirotazione con flangia (no semplice effetto)	
2	FUNZIONAMENTO 1 = semplice effetto, molla anteriore 2 = doppio effetto 3 = doppio effetto, stelo passante 4 = semplice effetto, molla posteriore	SIMBOLI PNEUMATICI CS06 CD08 CD12 CS08
A	CARATTERISTICHE MATERIALI A = testate e profilo in AL anodizzato - pistone in AL anodizzato guarnizione stelo, OR testate e guarnizione pistone in PU	
032	ALESAGGIO 020 = 20 mm - 025 = 25 mm - 032 = 32 mm - 040 = 40 mm 050 = 50 mm - 063 = 63 mm - 080 = 80 mm - 100 = 100 mm	
A	TIPO COSTRUTTIVO A = standard	
050	CORSA (vedi tabella)	
	= standard V = guarnizione stelo in FKM W = alte temperature (doppio effetto non magnetico con guarnizioni in FKM per alte temperature 140°)	

SIMBOLI PNEUMATICI

I simboli pneumatici indicati nell'ESEMPIO DI CODIFICA sono riportati di seguito.

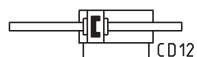

ACCESSORI DISPONIBILI PER LA SERIE 32

Snodo sferico maschio
Mod. GY

Dado stelo Mod. U



Spinotto Mod. S

Cerniera con snodo
Mod. RGiunto compensatore
Mod. GKF

Snodo sferico Mod. GA

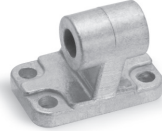
Supp. 90° per cerniera
femmina Mod. ZCCombinazione di
accessori Mod. C+L+SFlangia anteriore e post.
Mod. D-ESnodo autoallineante
Mod. GK

Controcerniera Mod. I

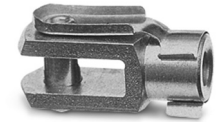

Piedini Mod. B

Cerniera femmina ant.
Mod. H e C-HCerniera femmina post.
Mod. C e C-H

Forcella Mod. G

Cerniera maschio post.
Mod. LBoccola di centraggio
Mod. TR

Tutti gli accessori sono forniti separatamente al cilindro.

Diagrammi carichi ammissibili

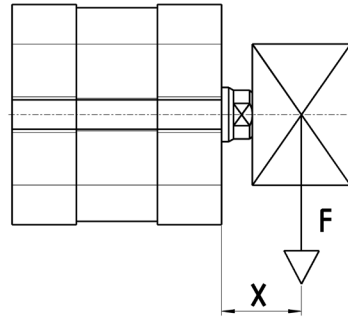
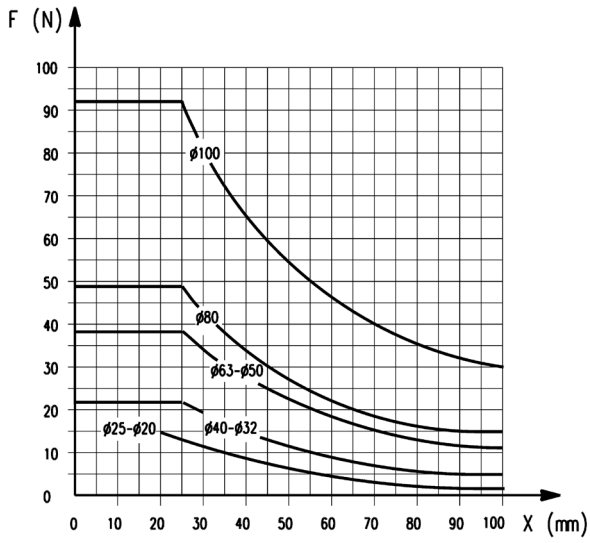

Standard.
Carico trasversale (F) in funzione della sporgenza (X)

Diagrammi carichi ammissibili

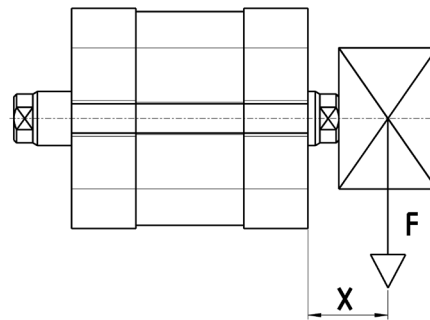
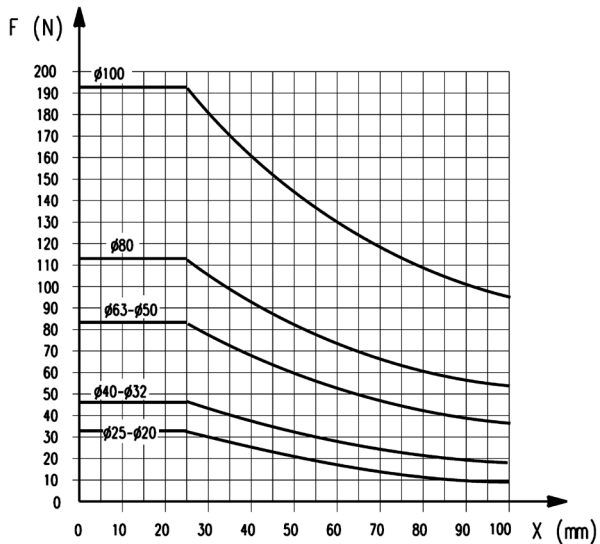

Stelo passante.
Carico trasversale (F) in funzione della sporgenza (X)

Diagrammi carichi ammissibili

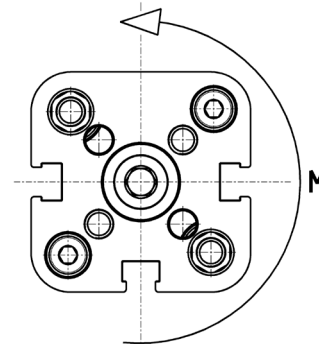
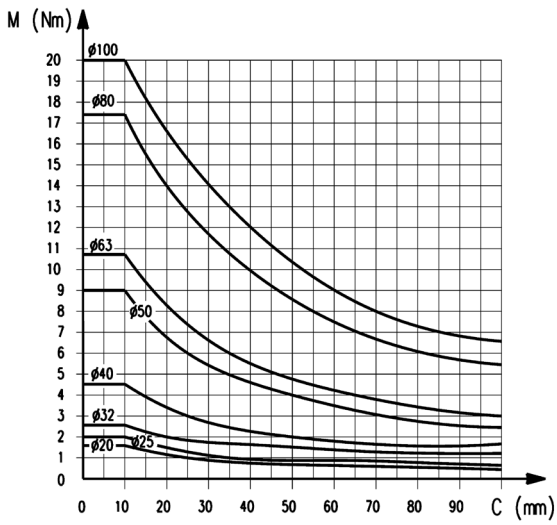

E' possibile realizzare corse come indicato nelle caratteristiche generali in assenza di carichi radiali e momenti torcenti. Qualora l'utilizzo del cilindro preveda carichi radiali, attenersi alla sporgenza massima del baricentro. In presenza di momenti torcenti, attenersi alla corsa massima riportata nei grafici.

Momento torcente (M) in funzione della corsa (C).

Diagrammi carichi ammissibili

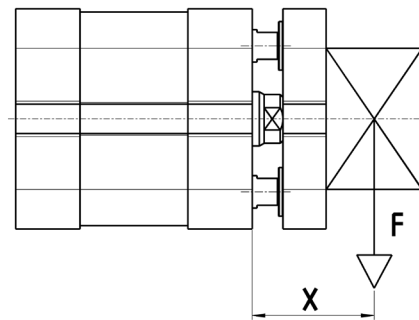
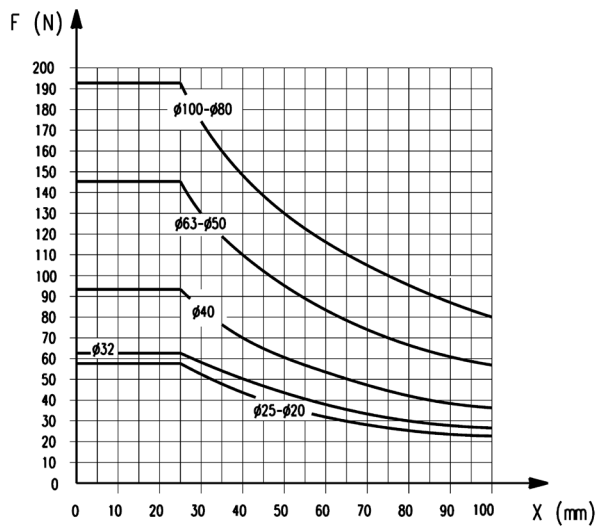

Antitrotazione.
Carico trasversale (F) in funzione della sporgenza (X).

Diagrammi carichi ammissibili

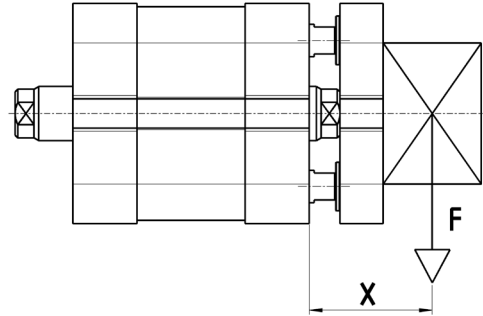
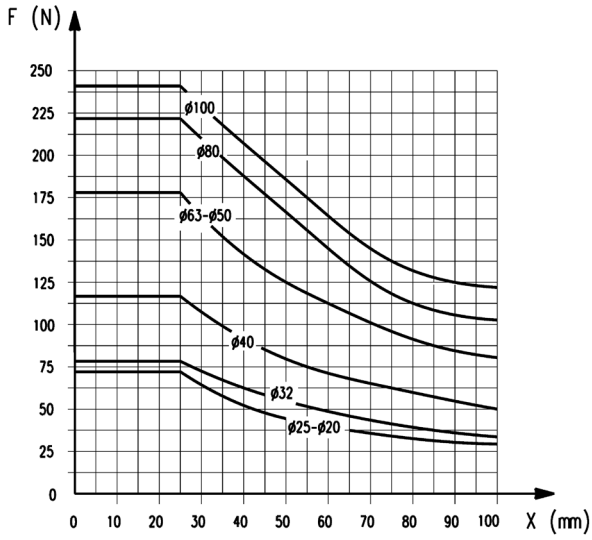

Antirotazione stelo passante.
Carico trasversale (F) in funzione della sporgenza (X).

Esempi di fissaggio

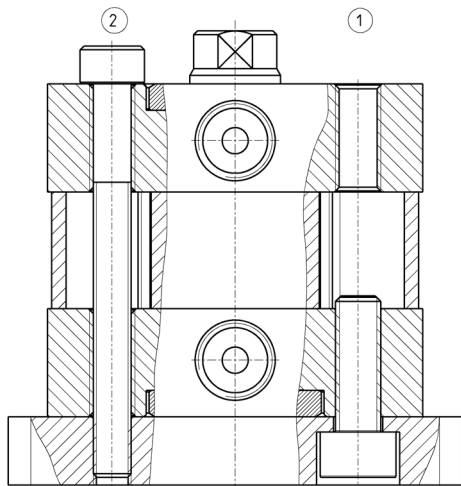

Esempio di fissaggio per Cilindri del Ø 32; 40; 50; 63; 80; 100.
1 = Fissaggio dal basso
2 = Fissaggio dall'alto

N.B. Per i fissaggi dall'alto con viti passanti attraverso il corpo del cilindro è consigliabile usare viti amagnetiche.

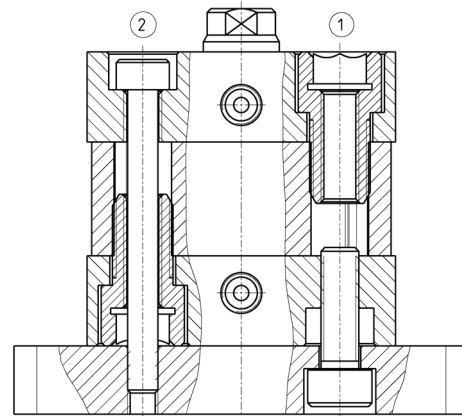

Esempio di fissaggio per Cilindri dal Ø 20 ÷ 25.
1 = Fissaggio dal basso
2 = Fissaggio dall'alto

N.B. Per i fissaggi dall'alto con viti passanti attraverso il corpo del cilindro è consigliabile usare viti amagnetiche.

Cilindri compatti magnetici Mod. 32F e 32M



+ = sommare la corsa
1 = scanalatura per sensore

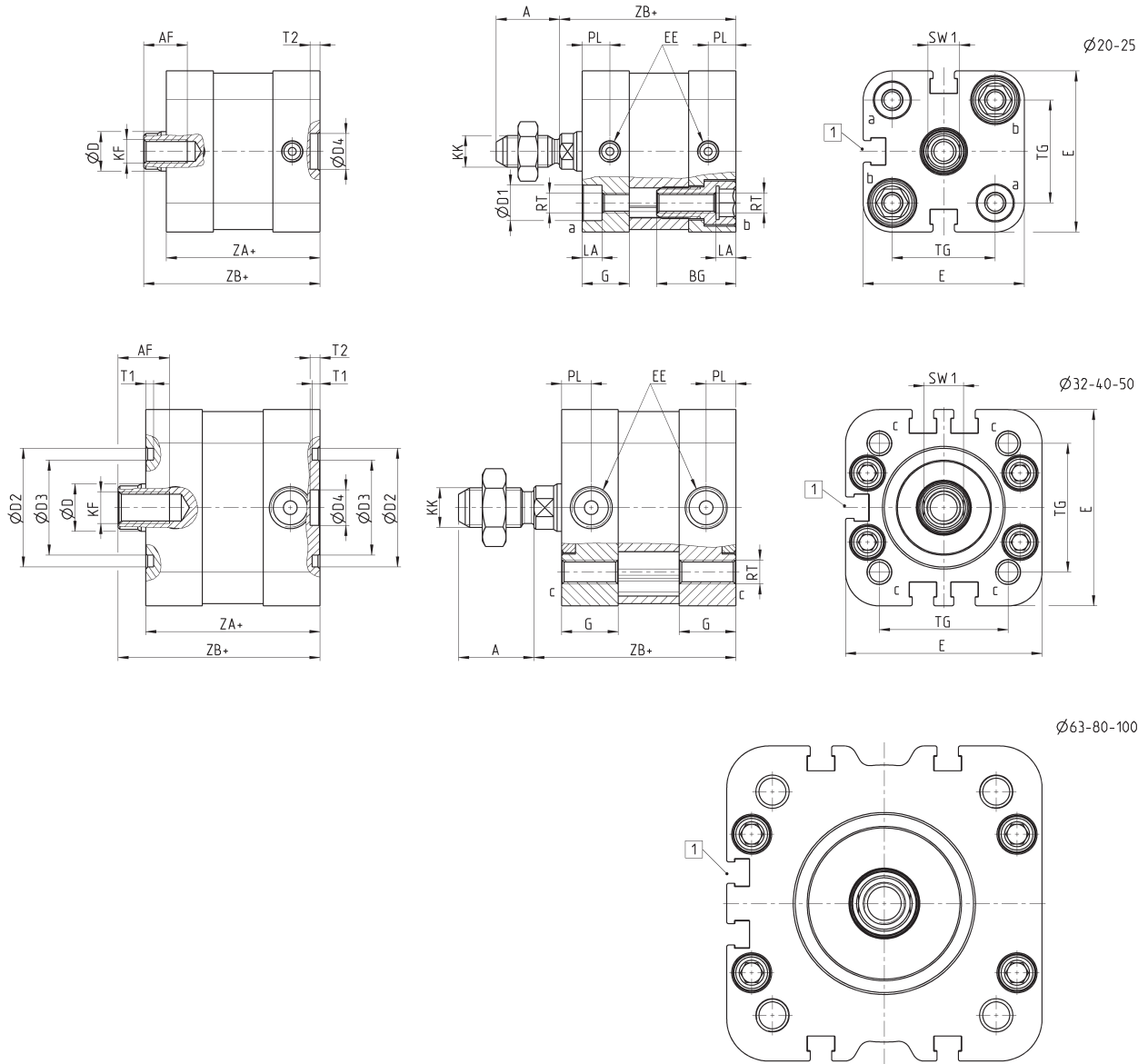

INGOMBRI																						
Ø	A	AF	BG	G	ØD	D1	ØD2	ØD3	ØD4	E	EE	KF	KK	LA	PL	RT	SW1	T1	T2	TG	ZA	ZB
20	16	11	20	10,9	10	9	-	-	9	35,8	M5	M6	M8X1,25	5	6,5	M5	8	-	2,5	22	36,8	42,5
25	16	11	20	11,9	10	9	-	-	9	40,7	M5	M6	M8X1,25	5	7	M5	8	-	2,5	26	38,8	44,5
32	19	13	-	14,3	12	-	30	24	9	49,6	G1/8	M8	M10X1,25	-	7,6	M6	10	2	2,5	32,5	44	51
40	19	13	-	14,3	12	-	35	29	9	57	G1/8	M8	M10X1,25	-	7,6	M6	10	2	2,5	38	45	52
50	22	16	-	14,3	16	-	40	34	12	69,6	G1/8	M10	M12X1,25	-	7,6	M8	13	2	3	46,5	45	53
63	22	16	-	14	16	-	45	39	12	79,6	G1/8	M10	M12X1,25	-	7,6	M8	13	2	3	56,5	49	57
80	28	20	-	14,8	20	-	45	39	12	95,6	G1/8	M12	M16X1,5	-	7,7	M10	17	2	3	72	54	63,5
100	28	20	-	17,8	25	-	55	49	12	115,6	G1/8	M12	M16X1,5	-	8	M10	22	2	3	89	66,8	76,5

Cilindri compatti magnetici Mod. 32F3 e 32M3



+ = sommare la corsa
++ = sommare due volte la corsa
1 = scanalatura per sensore

CILINDRI SERIE 32

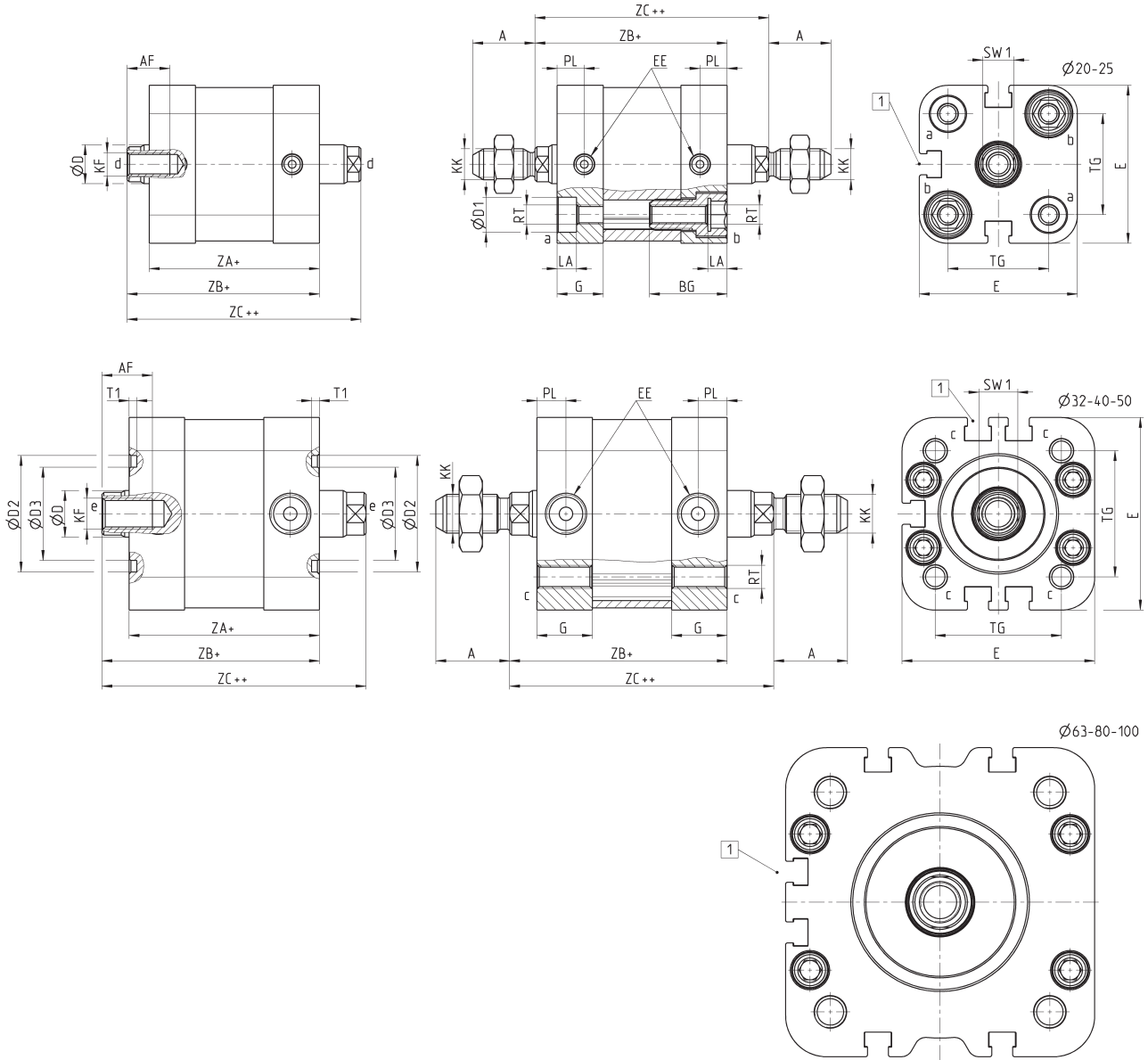

INGOMBRI																					
Ø	A	AF	BG	G	ØD	ØD1	ØD2	ØD3	E	EE	KF	KK	LA	PL	RT	SW1	T1	TG	ZA	ZB	ZC
20	16	11	20	10,9	10	9	-	-	35,8	M5	M6	M8X1,25	5	6,5	M5	8	-	22	36,8	42,5	48,2
25	16	11	20	11,9	10	9	-	-	40,7	M5	M6	M8X1,25	5	7	M5	8	-	26	38,8	44,5	50,2
32	19	13	-	14,3	12	-	30	24	49,6	G1/8	M8	M10X1,25	-	7,6	M6	10	2	32,5	44	51	58
40	19	13	-	14,3	12	-	35	29	57	G1/8	M8	M10X1,25	-	7,6	M6	10	2	38	45	52	59
50	22	16	-	14,3	16	-	40	34	69,6	G1/8	M10	M12X1,25	-	7,6	M8	13	2	46,5	45	53	61
63	22	16	-	14	16	-	45	39	79,6	G1/8	M10	M12X1,25	-	7,6	M8	13	2	56,5	49	57	65
80	28	20	-	14,8	20	-	45	39	95,6	G1/8	M12	M16X1,5	-	7,7	M10	17	2	72	54	63,5	73
100	28	20	-	17,8	25	-	55	49	115,6	G1/8	M12	M16X1,5	-	8	M10	22	2	89	66,8	76,5	86,2

Cilindri compatti magnetici Mod. 32R



+ = sommare la corsa
 ++ = sommare due volte la corsa
 1 = scanalatura per sensore

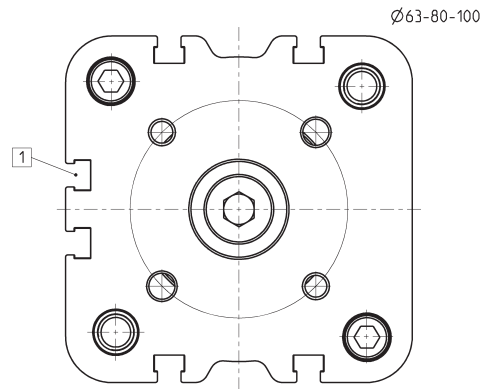
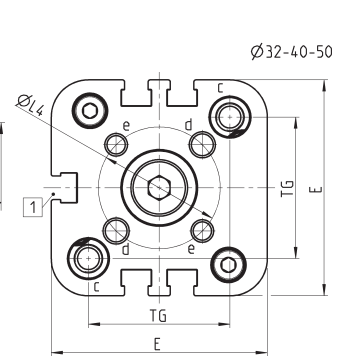
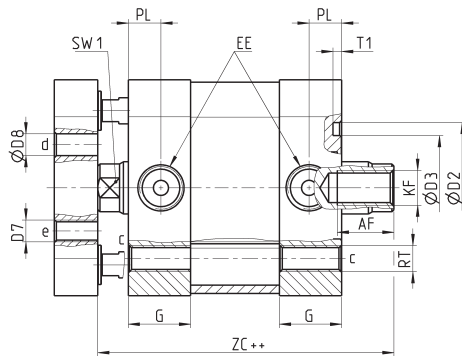
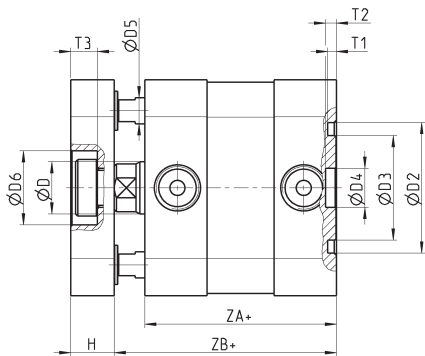
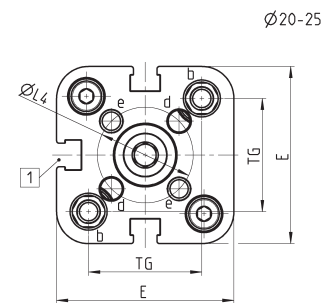
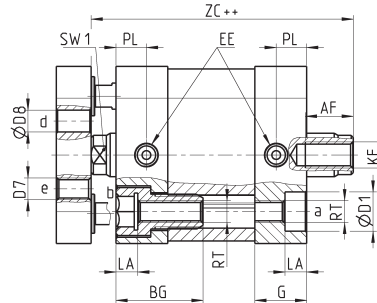
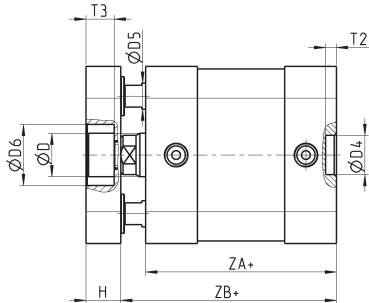

INGOMBRI																												
Ø	AF	BG	G	ØD	ØD1	ØD2	ØD3	ØD4	ØD5	ØD6	D7	ØD8	E	EE	H	KF	LA	ØL4	PL	RT	SW1	T1	T2	T3	TG	ZA	ZB	ZC
20	11	20	10.9	10	9	-	-	9	6	-	M4	4	35.8	M5	8	M6	5	17	6.5	M5	8	-	2.5	-	22	36.8	42.5	48.2
25	11	20	11.9	10	9	-	-	9	6	14	M5	5	40.7	M5	8	M6	5	22	7	M5	8	-	2.5	6.5	26	38.8	44.5	50.2
32	13	-	14.3	12	-	30	24	9	6	17	M5	5	49.6	G1/8	10	M8	-	28	7.6	M6	10	2	2.5	6	32.5	44	51	58
40	13	-	14.3	12	-	35	29	9	6	17	M5	5	57	G1/8	10	M8	-	33	7.6	M6	10	2	2.5	6	38	45	52	59
50	16	-	14.3	16	-	40	34	12	10	22	M6	6	69.6	G1/8	12	M10	-	42	7.6	M8	13	2	3	7	46.5	45	53	61
63	16	-	14	16	-	45	39	12	10	22	M6	6	79.6	G1/8	12	M10	-	50	7.6	M8	13	2	3	7	56.5	49	57	65
80	20	-	14.8	20	-	45	39	12	12	24	M8	8	95.6	G1/8	14	M12	-	65	7.7	M10	17	2	3	10.5	72	54	63.5	73
100	20	-	18	25	-	55	49	12	12	24	M10	10	115.6	G1/8	14	M12	-	80	8	M10	22	2	3	10.5	89	67	76.7	86.2

Ancoraggio a piedini Mod. B

Materiale: Acciaio zincato



La fornitura comprende:
N° 2 Piedini
N° 4 Viti

+ = sommare la corsa

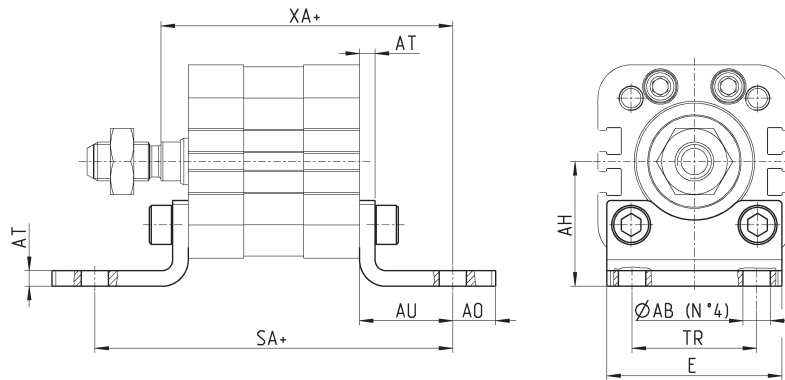

INGOMBRI										
Mod.	Ø	ØAB	AH	AO	AU	AT	E	TR	SA	XA
B-32-20	20	6,5	27	9	16	4	35	22	68,8	58,5
B-31-25	25	6,5	29	9	16	4	39	26	70,8	60,5
B-41-32	32	7	32	11	24	4	45	32	92	75
B-41-40	40	10	36	15	28	4	53,5	36	101	80
B-41-50	50	10	45	15	32	4	62,5	45	109	85
B-41-63	63	10	50	15	32	5	73	50	113	89
B-41-80	80	12	63	20	41	6	92	63	136	104,5
B-41-100	100	14,5	71	25	41	6	108,5	71	148,8	117,5

Ancoraggio a cerniera femmina posteriore Mod. C e C-H

Materiale: Alluminio



La fornitura comprende:
N° 1 Cerniera Femmina
N° 4 Viti

+ = sommare la corsa

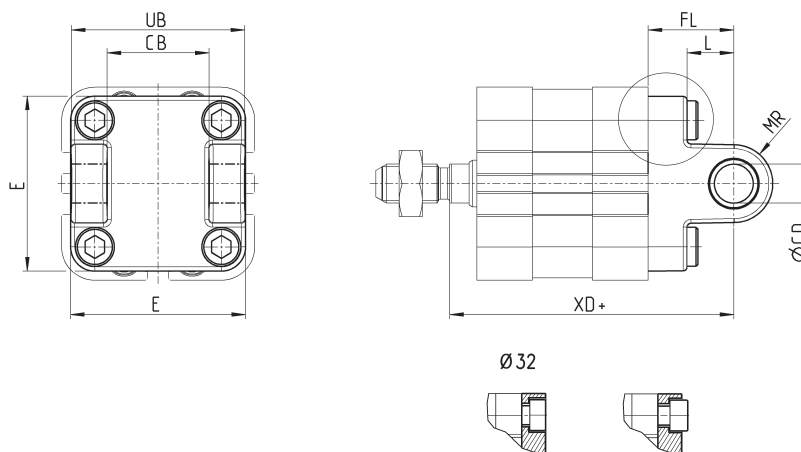

INGOMBRI									
Mod.	Ø	ØCD	E	CB	UB	L	FL	MR	XD+
C-41-32	32	10	47	26	46,5	12,5	22	10	73
C-41-40	40	12	52	28	52	16	25	12	77
C-41-50	50	12	64	32	60	16	27	12	80
C-H-41-63	63	16	74	40	70	21	32	16	89
C-H-41-80	80	16	94	50	90	22	36	16	99,5
C-H-41-100	100	20	114	60	110	27	41	20	117,5

Ancoraggio a cerniera femmina anteriore Mod. H e C-H

Materiale: Alluminio



La fornitura comprende:
N° 1 Cerniera Femmina
N° 4 Viti

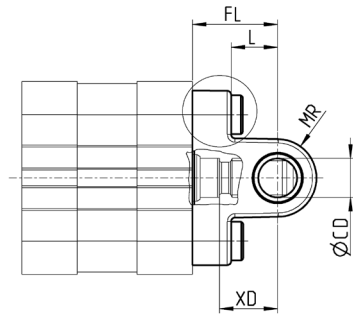
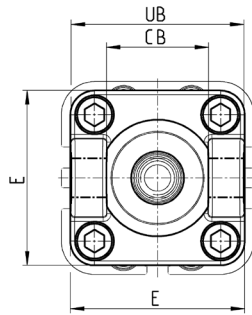

Ø 32



INGOMBRI									
Mod.	Ø	ØCD	E	CB	UB	L	FL	MR	XD
H-41-32	32	10	47	26	46.5	12.5	22	10	15
H-41-40	40	12	52	28	52	16	25	12	18
H-41-50	50	12	64	32	60	16	27	12	19
H-60-63	63	16	74	40	70	21	32	16	24
C-H-41-80	80	16	94	50	90	22	36	16	26,5
C-H-41-100	100	20	114	60	110	27	41	20	31,3

Ancoraggio a flangia anteriore e posteriore Mod. D-E

Materiale: Acciaio zincato per i Ø 20 - Ø 25; Alluminio dal Ø 32 - Ø 100



La fornitura comprende:
N° 1 Flangia
N° 4 Viti

+ = sommare la corsa

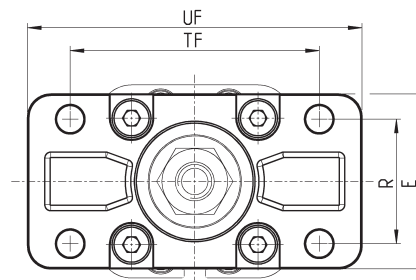
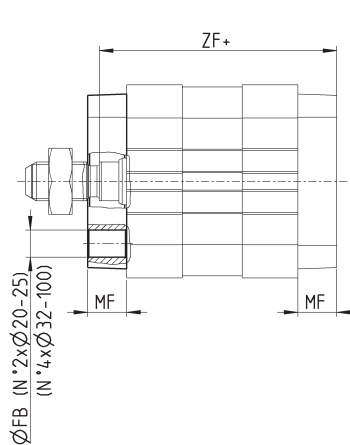

INGOMBRI								
Mod.	Ø	ØFB	E	MF	R	TF	UF	ZF+
D-E-32-20	20	6,6	36	10	-	55	70	52,5
D-E-32-25	25	6,6	40	10	-	60	76	54,5
D-E-41-32	32	7	45	10	32	64	80	61
D-E-41-40	40	9	52	10	36	72	90	62
D-E-41-50	50	9	65	12	45	90	110	65
D-E-41-63	63	9	75	12	50	100	120	69
D-E-41-80	80	12	95	16	63	126	150	79,5
D-E-41-100	100	14	115	16	75	150	170	92,5

Ancoraggio a cerniera maschio posteriore Mod. L

Materiale: Alluminio

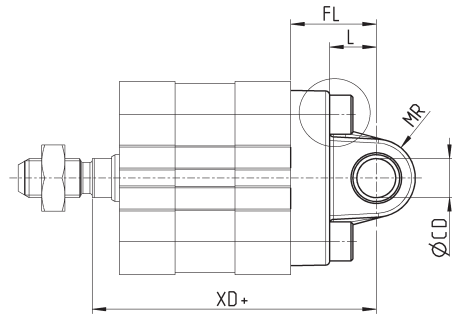
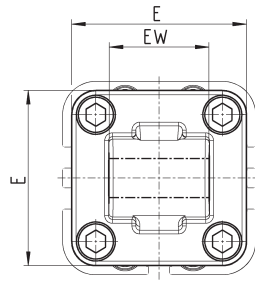

La fornitura comprende:
N° 1 Cerniera maschio
N° 4 Viti

+ = sommare la corsa

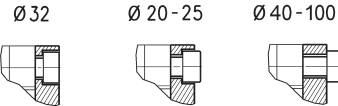

INGOMBRI								
Mod.	Ø	Ø _{CD}	E	EW	L	FL	MR	XD+
L-32-20	20	8	34	16	14	20	8	62,5
L-32-25	25	8	38	16	14	20	8	64,5
L-41-32	32	10	47	26	12,5	22	10	73
L-41-40	40	12	52	28	16	25	12	77
L-41-50	50	16	64	32	16	27	12	80
L-41-63	63	16	74	40	21	32	15,5	89
L-41-80	80	20	94	50	22	36	16	99,5
L-41-100	100	20	114	60	27	41	20	117,5

Ancoraggio a cerniera maschio post. con snodo sferico Mod. R

* Ancoraggio non a norma ISO 15552
Materiale: Alluminio

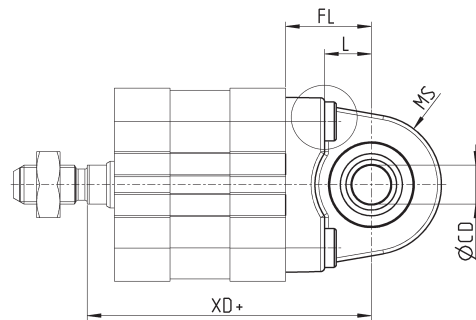
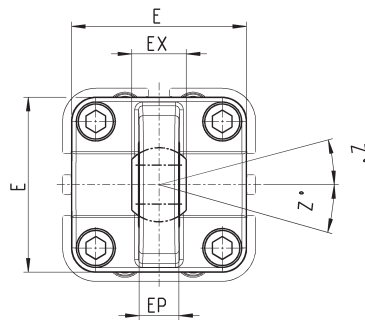

La fornitura comprende:
N° 1 Cerniera snodata
N° 4 Viti

+ = sommare la corsa

R-41-50/80



INGOMBRI										
Mod.	Ø	Ø _{CD}	E	EX	EP	L	FL	MS	XD+	Z°
R-41-32	32	10	45	14	10,5	12	22	16	73	4
R-41-40	40	12	52	16	12	15	25	19	77	4
R-41-50*	50	12	62,5	16	12	15	27	21	80	4
R-50	50	16	65	21	15	16	27	21,5	80	4
R-41-63	63	16	75	21	15	20	32	24	89	4
R-41-80*	80	16	92	21	15	24	36	28	99,5	4
R-80	80	20	95	25	18	22	36	28,5	99,5	4
R-41-100	100	20	115	25	18	25	41	30	117,5	4

Combinazione di accessori modelli C+L+S

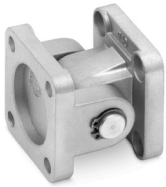

Materiale: Alluminio

+ = sommare la corsa

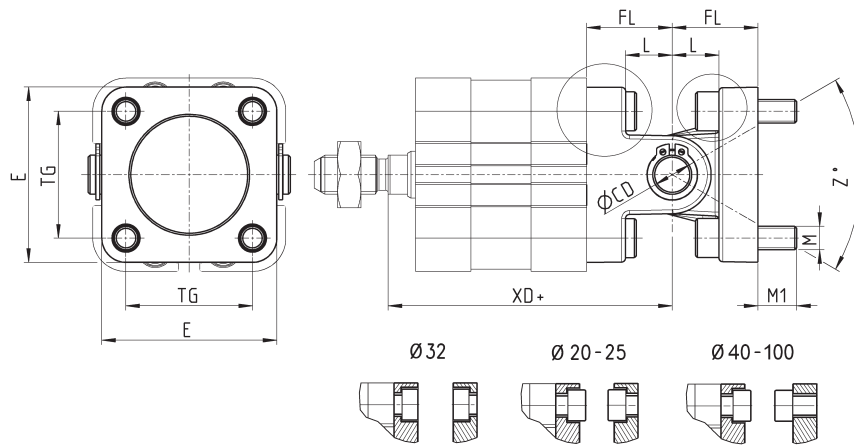

INGOMBRI										
Mod.	Ø	ØCD	E	L	FL	M	M1	TG	XD+	Z° (max)
C+L+S	32	10	47	12.5	22	M6	10.5	32.5	73	30
C+L+S	40	12	52	16	25	M6	10.5	38	77	40
C+L+S	50	12	64	16	27	M8	11.5	46.5	80	25
C+L+S	63	16	74	21	32	M8	13.5	56.5	89	36
C+L+S	80	16	93	22	36	M10	15	72	99.5	34
C+L+S	100	20	114	27	41	M10	15	89	117.5	38

Supporto a 90° per cerniera femmina posteriore Mod. ZC

Materiale: Alluminio

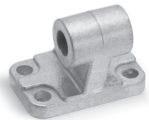

La fornitura comprende:
N° 1 Supporto maschio

+ = sommare la corsa

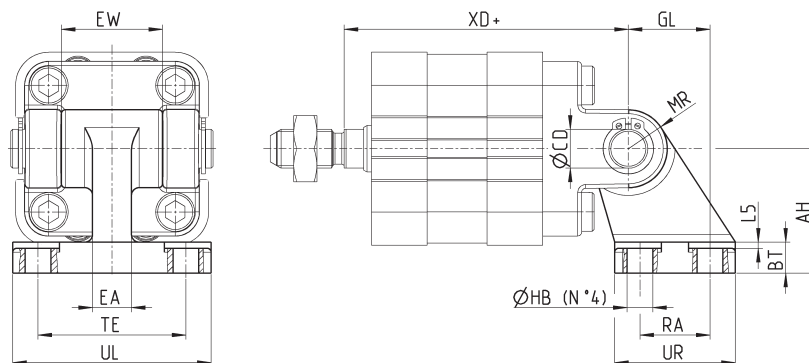

INGOMBRI															
Mod.	Ø	AH	BT	ØCD	EA	EW	GL	ØHB	L5	MR	RA	UL	UR	TE	XD
ZC-32	32	32	8	10	10	26	21	6,6	1,6	10	18	51	31	38	73
ZC-40	40	36	10	12	15	28	24	6,6	1,6	11	22	54	35	41	77
ZC-50	50	45	12	12	16	32	33	9	1,6	13	30	65	45	50	80
ZC-63	63	50	14	16	16	40	37	9	1,6	15	35	67	50	52	89
ZC-80	80	63	14	16	20	50	47	11	2,5	15	40	86	60	66	99,5
ZC-100	100	71	17	20	20	60	55	11	2,5	19	50	96	70	76	117,5

Supporto 90° per cerniera femmina posteriore Mod. I

Materiale: Acciaio zincato

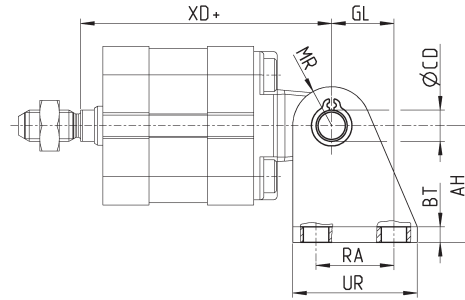
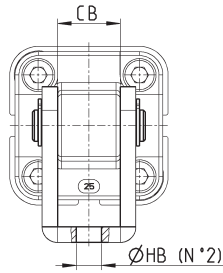

La fornitura comprende:
N° 1 Supporto femmina
N° 2 Seeger
N° 1 Spinotto

+ = sommare la corsa

CILINDRI SERIE 32

INGOMBRI											
Mod.	Ø	AT	BT	CD	CB	GL	HB	MR	RA	UR	XD
I-20-25	20	30	4	8	16,1	16	6,5	10	20	32	62,5
I-20-25	25	30	4	8	16,1	16	6,5	10	20	32	64,5

Spinotto Mod. S

Materiali: Spinotto INOX, Seeger Acciaio

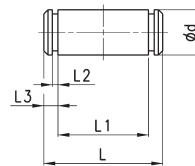

La fornitura comprende:
N° 1 Spinotto
N° 2 Seeger

INGOMBRI						
Mod.	Ø	D	L	L1	L2	L3
S-32	32	10	52	46	1,1	3
S-40	40	12	59	53	1,1	3
S-50	50	12	67	61	1,1	3
S-63	63	16	77	71	1,1	3
S-80	80	16	97	91	1,1	3
S-100	100	20	121	111	1,3	5

Forcella Mod. G

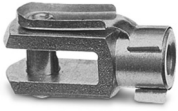

ISO 8140
Materiale: Acciaio zincato

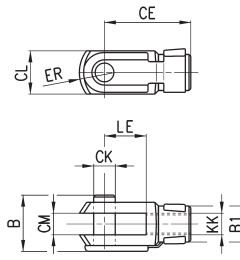

INGOMBRI										
Mod.	∅	∅ _{CK}	LE	CM	CL	ER	CE	KK	B	∅ _{B1}
G-20	20-25	8	16	8	16	10	32	M8X1,25	22	14
G-25-32	32-40	10	20	10	20	12	40	M10x1,25	26	18
G-40	50-63	12	24	12	24	14	48	M12x1,25	32	20
G-50-63	80-100	16	32	16	32	19	64	M16x1,5	40	26

Snodo sferico maschio Mod. GY

Materiale: Zama e Acciaio zincato

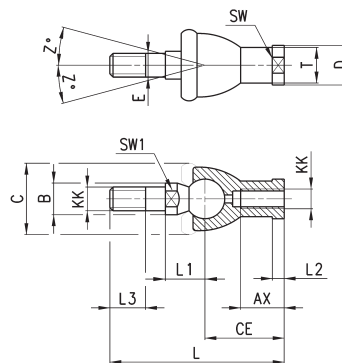

INGOMBRI																	
Mod.	∅	KK	L	CE	L2	AX	SW	SW1	L1	L3	∅ _T	∅ _D	E	∅ _B	∅ _C	Z	
GY-20	20-25	M8X1,25	65	32	5	16	14	10	16	12	12,5	13	6	10	20	15	
GY-32	32-40	M10X1,25	74	35	6,5	18	17	11	19,5	15	15	19	10	14	28	15	
GY-40	50-63	M12X1,25	84	40	6,5	20	19	17	21	17	17,5	22	12	19	32	15	
GY-50-63	80-100	M16X1,5	112	50	8	27	22	19	27,5	23	22	27	16	22	40	11	

Snodo sferico Mod. GA



ISO 8139
Materiale: acciaio zincato

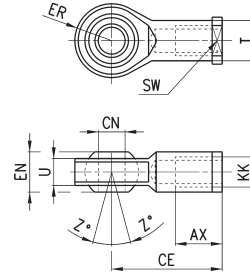

INGOMBRI											
Mod.	∅	∅CN	U	EN	ER	AX	CE	KK	∅T	Z	SW
GA-20	20-25	8	9	12	12	16	36	M8X1,25	12,5	6,5	14
GA-32	32-40	10	10,5	14	14	20	43	M10x1,25	15	6,5	17
GA-40	50-63	12	12	16	16	22	50	M12X1.25	17,5	6,5	19
GA-50-63	80-100	16	15	21	21	28	64	M16x1,5	22	7,5	22

Dado stelo Mod. U



UNI EN ISO 4035
Materiale: Acciaio zincato

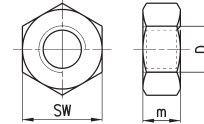

INGOMBRI				
Mod.	∅	D	M	SW
U-20	20-25	M8X1.25	5	13
U-25-32	32-40	M10X1,25	6	17
U-40	50-63	M12X1,25	7	19
U-50-63	80-100	M16X1,5	8	24

Boccola di centraggio Mod. TR



La fornitura comprende:
N° 1 Anello di centraggio in AL anodizzato

Concepiti sia per il centraggio delle testate posteriori ed anteriori con gli ancoraggi mod. B/D-E/C/C-H/H/L/R, che per il centraggio del cilindro in fase di montaggio.

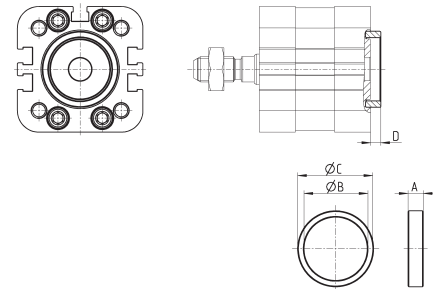

INGOMBRI					
Mod.	∅	A	∅B	∅C	D
TR-32-32	32	6	25	30	4
TR-32-40	40	6	30	35	4
TR-32-50	50	6	35	40	4
TR-32-63	63-80	7	40	45	5
TR-32-100	100	7	50	55	5

Perno di centraggio Mod. TS-32-20

Materiale: Alluminio anodizzato

Concepito per il centraggio sia delle testate post. con gli ancoraggi L-32-20 / L-32-25 che del cilindro in fase di montaggio, è utilizzabile anche nei fori "a" delle testate ant./post. di cil. ∅20-∅25 o nel foro centrale delle testate post. di cil. ∅32-∅40.

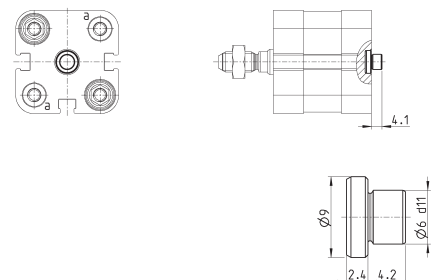

Mod.	TS-32-20
------	----------

Snodo autoallineante Mod. GK

Solo per cilindri con stelo maschio

Materiale: Acciaio zincato

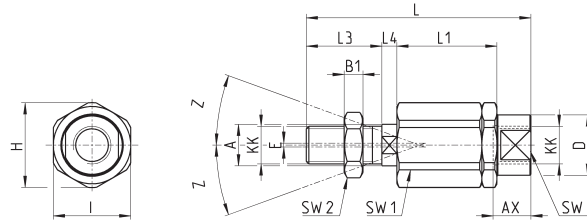

INGOMBRI																		
Mod.	Ø	KK	L	L1	L3	L4	ØA	ØD	H	I	SW	SW1	SW2	B1	AX	Z	E	
GK-20	20-25	M8x1,25	57	26	21	5	8	12,5	19	17	11	7	13	4	16	4	2	
GK-25-32	32-40	M10x1,25	71,5	35	20	7,5	14	22	32	30	19	12	17	5	22	4	2	
GK-40	50-63	M12x1,25	75,5	35	24	7,5	14	22	32	30	19	12	19	6	22	4	2	
GK-50-63	80-100	M16x1,5	104	53	32	10	22	32	45	41	27	20	24	8	30	3	2	

Giunto compensatore Mod. GKF

Materiale: Acciaio zincato

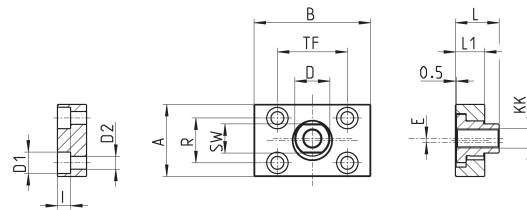

INGOMBRI															
Mod.	Ø	KK	A	B	R	TF	L	L1	I	ØD	ØD1	ØD2	SW	E	
GKF-20	20-25	M8x1,25	30	35	20	25	22,5	10	-	14	5,5	-	13	1,5	
GKF-25-32	32-40	M10x1,25	37	60	23	36	22,5	15	6,8	18	11	6,6	15	2	
GKF-40	50-63	M12x1,25	56	60	38	42	22,5	15	9	20	15	9	15	2,5	
GKF-50-63	80-100	M16x1,5	80	80	58	58	26,5	15	10,5	25	18	11	22	2,5	