

Series MC activated carbon filters



Ports: G1/4, G3/8 e G1/2

Modular

Metal bowl and bayonet-type mounting



- » Removal of oil, liquid and gaseous components from compressed air through the activated carbon
- » Quality of delivered air according to ISO 8573-1:2010, Class 1.7.1

The activated carbon filters Serie MC are available with port G1/4, G3/8 and G1/2. The bowls of these filters are made of metal with a transparent sight glass

GENERAL DATA

Construction	modular, compact with activated carbon filtering element			
Materials	zama, NBR, tecnopolymer, activated carbon			
Ports	G1/4	G3/8	G1/2	
Weight	Kg	0,342	0,718	0,688
Mounting	vertical in line or wall-mounting			
Operating temperature	10°C ÷ 40°C (t max = 60°C)			
Quality of delivered air according to ISO 8573-1:2010	Class 1.7.1			
Condensate drain	not present			
Mounting	vertical in-line; wall-mounting by means of through holes in the body or with a support bracket			
Operating pressure	0.3 ÷ 16 bar			
Nominal flow	see FLOW DIAGRAMS on the following pages			
Filtering element	active carbon			
Residual oil content	< 0.003 mg/m ³			
Fluid	compressed air			
Pre-filtering	it is recommended to use a filter with residual oil of 0,01mg/m ³			

CODING EXAMPLE

MC	2	02	-	F	CA
-----------	----------	-----------	----------	----------	-----------

MC	SERIES
2	SIZE: 1 = G1/4 2 = G3/8 - G1/2
02	PORTS: 04 = G1/4 38 = G3/8 02 = G1/2
F	FILTER
CA	CA = Activated carbon

SERIES MC ACTIVATED CARBON FILTERS

Series MC activated carbon filters



FC01 = Absorption function without bowl hole

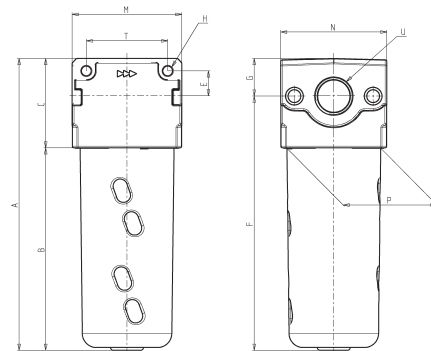

Mod.	A	B	C	E	F	G	H	M	N	P	T	U
MC104-FCA	124	83	41	11	107,5	16,5	4,5	45	45	37	35	G1/4
MC238-FCA	166	115	51	14	145	21	5,5	62	60	53	46	G3/8
MC202-FCA	166	115	51	14	145	21	5,5	62	60	53	46	G1/2

FLOW DIAGRAMS

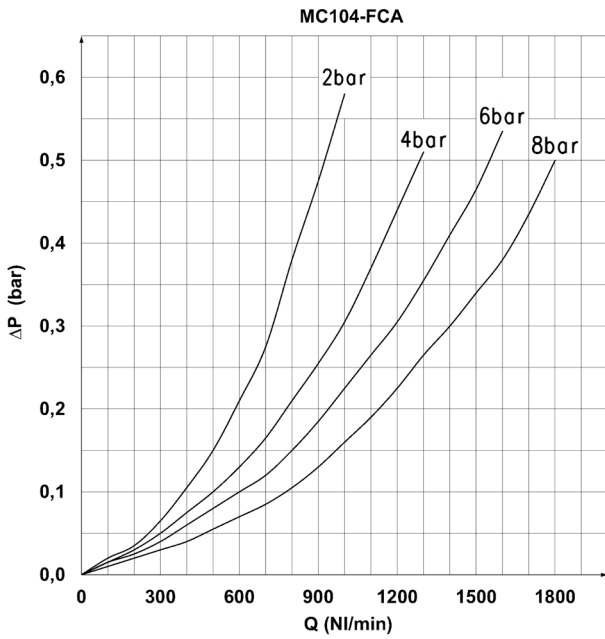

Flow diagram for model: MC104-FCA
 ΔP = Pressure drop (bar)
 Q = Flow (NL/min)

In order to guarantee the indicated performances, the maximum flow of the filter must be the one indicated in the graph. A higher flow rate is possible but the same performances are not guaranteed.

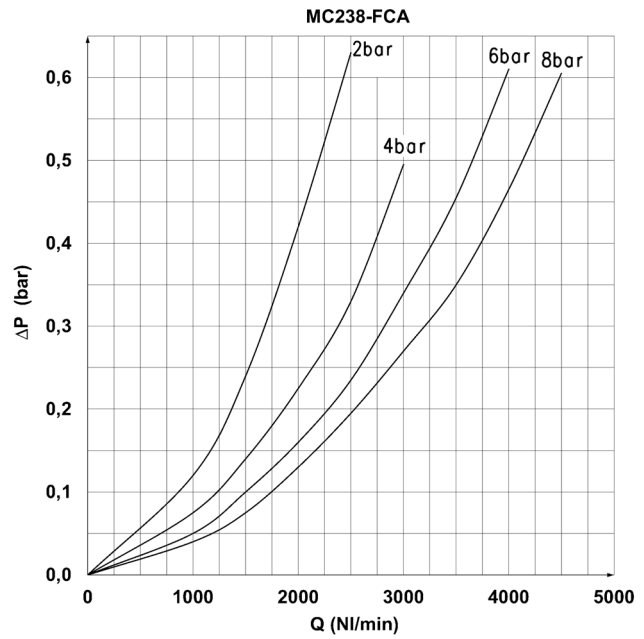

Flow diagram for model: MC238-FCA
 ΔP = Pressure drop (bar)
 Q = Flow (NL/min)

In order to guarantee the indicated performances, the maximum flow of the filter must be the one indicated in the graph. A higher flow rate is possible but the same performances are not guaranteed.

FLOW DIAGRAM

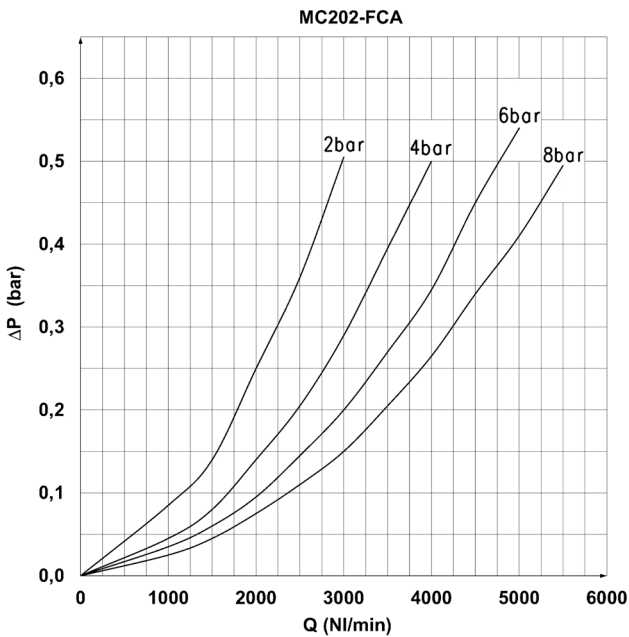

Flow diagram for model: MC202-FCA
 ΔP = Pressure drop (bar)
 Q = Flow (NL/min)

In order to guarantee the indicated performances, the maximum flow of the filter must be the one indicated in the graph. A higher flow rate is possible but the same performances are not guaranteed.