

Series MC coalescing filters

Ports G1/4, G3/8 and G1/2
Modular
Metal bowl and bayonet-type mounting



- » Quality of delivered air according to ISO 8573-1:2010, Class 1.8.1
- » Manual, automatic or depressuring drain

Series MC coalescing filters are available with G1/4, G3/8 and G1/2 ports. The bowls of these filters are made of metal with a transparent sight glass and may have a condensate drain valve which can provide either a manual or semi-automatic function.

GENERAL DATA

Construction	modular, coalescing elements
Materials	zama, NBR, technopolymer
Ports	G1/4 G3/8 G1/2
Weight	kg 0.342 0.718 0.688
Mounting	vertical in line or wall-mounting
Operating temperature	-5°C ÷ 50°C at 10 bar (with the dew point of the fluid lower than 2°C at the min. working temperature)
Quality of delivered air according to ISO 8573-1:2010	Class 1.8.1 with 0.01 µm filtering element
Draining of condensate	manual - semi-automatic (standard), automatic, with depressurisation, protected depressurisation, without drain with port G1/8
Finish	enamelled
Operating pressure	with standard drain and protected depressurisation 0.3 ÷ 16 bar with depressurisation 0.3 ÷ 10 bar with automatic drain 1.5 ÷ 12 bar for G3/8 and G1/2
Residual oil content with inlet at 3 mg/m³	< 0.01mg/m ³
Oil retain efficiency	99.80%
Particles retain efficiency	99.99999%
Nominal flow	see FLOW DIAGRAMS on the following pages
Fluid	compressed air

CODING EXAMPLE

MC	2	02	-	F	B	0
-----------	----------	-----------	----------	----------	----------	----------

MC	SERIES
2	SIZE: 1 = G1/4 2 = G3/8 - G1/2
02	PORTS: 04 = G1/4 38 = G3/8 02 = G1/2
F	F = FILTER
B	FILTERING ELEMENT: B = 0,01µm
0	DRAINING OF CONDENSATE (further details in the dedicated section): 0 = manual - semi-automatic 3 = automatic (only for G3/8 and G1/2) 4 = depressurisation (only G1/4) 5 = depressurisation, protected 8 = no drain, port 1/8

SERIES MC COALESCING FILTERS

Coalescing filters Series MC



FA01 = coalescing filter without drain with threaded port
FA02 = coalescing filter with semi-automatic manual drain
FA03 = coalescing filter with automatic drain

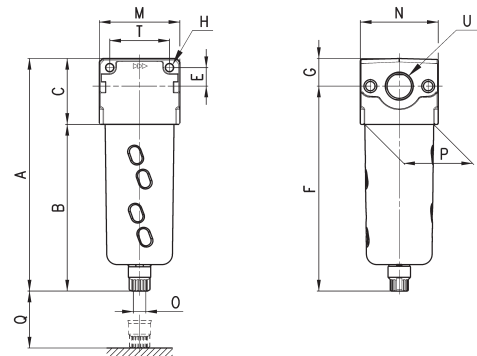
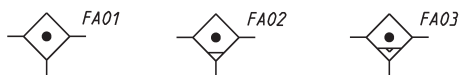

DIMENSIONS															
Mod.	A	B	C	E	F	G	H	M	N	O	P	Q	T	U	
MC104-FB0	143	102	41	11	126,5	16,5	4,5	45	45	G1/8	37	54	35	G1/4	
MC238-FB0	184	133	51	14	163	21	5,5	62	60	G1/8	53	73	46	G3/8	
MC202-FB0	184	133	51	14	163	21	5,5	62	60	G1/8	53	73	46	G1/2	

FLOW DIAGRAMS

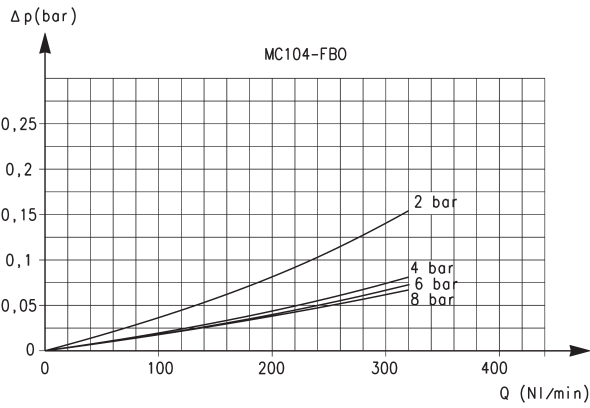

Flow diagram for model: MC104-FB0
 ΔP = Pressure drop (bar)
 Q = Flow (NL/min)

In order to guarantee the indicated performances, the maximum flow of the filter must be the one indicated in the graph. A higher flow rate is possible but the same performances are not guaranteed.

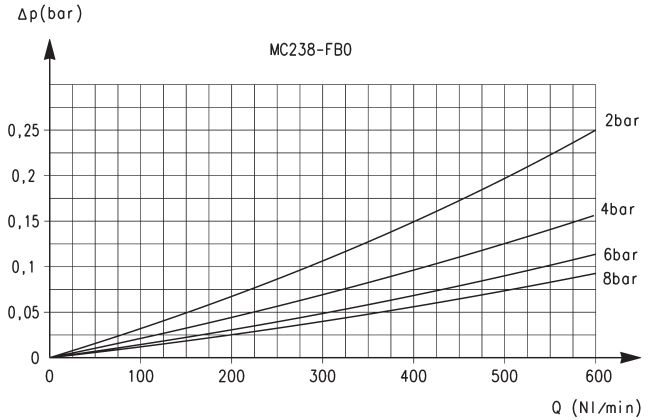

Flow diagram for model: MC238-FB0
 ΔP = Pressure drop (bar)
 Q = Flow (NL/min)

In order to guarantee the indicated performances, the maximum flow of the filter must be the one indicated in the graph. A higher flow rate is possible but the same performances are not guaranteed.

FLOW DIAGRAM

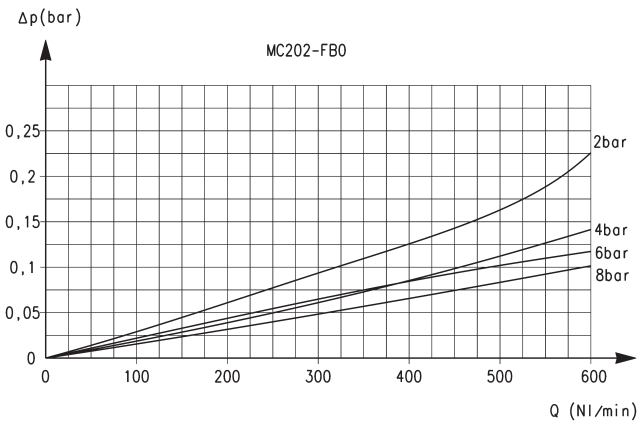

Flow diagram for model: MC202-FB0
 ΔP = Pressure drop (bar)
 Q = Flow (NL/min)

In order to guarantee the indicated performances, the maximum flow of the filter must be the one indicated in the graph. A higher flow rate is possible but the same performances are not guaranteed.