

Series MC manifold pressure regulators

Ports G1/4
Modular



- » Minimal pressure decreases
- » Knob with closure
- » Integral return exhaust (relieving)

The manifold pressure regulators with ports G1/4 are available with a second pressure relieving and can be in-line or panel mounted.

GENERAL DATA

Construction	compact modular, diaphragm type
Materials	zama, NBR, technopolymer
Port	G1/4
Weight	kg 0,320
Pressure gauge ports / outlet	G1/8
Mounting	in-line, wall or panel mounting (in any position)
Operating temperature	-5°C ÷ 50°C (with the dew point of the fluid lower than 2°C at the min. working temperature)
Finishing	enamelled
Inlet pressure	0 ÷ 16 bar
Outlet pressure	0.5 ÷ 10 bar or 0 ÷ 4 bar
Flow	see the FLOW DIAGRAM on the following page
Secondary pressure relieving	standard

CODING EXAMPLE

MC	1	04	-	M	T	0	2	-	■	-	●
----	---	----	---	---	---	---	---	---	---	---	---

MC	SERIES
1	SIZE: 1 = G1/4
04	PORT: 04 = G1/4
M	MANIFOLD REGULATOR
T	OPERATING PRESSURE 0 = 0.5 ÷ 10 bar (standard) 1 = 0 ÷ 4 bar 2 = 0.5 ÷ 2 bar 7 = 0.5 ÷ 7 bar
0	CONSTRUCTION: 0 = self-relieving (standard) 1 = non-relieving 5 = precise relieving
2	PRESSURE GAUGE = without pressure gauge (standard) 1 = with pressure gauge 0-2.5 with working pressure 0÷2 bar 2 = with pressure gauge 0-6 with working pressure 0÷4 bar 3 = with pressure gauge 0-10 with working pressure 0,5÷7 bar 4 = with pressure gauge 0-12 with working pressure 0,5÷10 bar
<p>** NOTE: IF THE REGULATOR IS CALIBRATED OR LOCKED, AFTER THE PORTS ADD THE INLET PRESSURE "■" AND THE OUTLET PRESSURE "●"</p> <p>INLET PRESSURE: ■ = enter the SUPPLY pressure value</p> <p>OUTLET PRESSURE: ● = enter the OUTLET pressure value for the LOCKED regulator or the maximum value of the ADJUSTABLE pressure for the CALIBRATED regulator</p> <p>Example of a calibrated regulator with Inlet Pressure = 6.3 bar and Outlet Pressure = 4.5 bar Complete part number: MC104-MT03-6.3-4.5</p> <p>** the pressure gauges are supplied disassembly for size 1 pressure gauge mod. M043-P. for size 2 pressure gauge mod.M053-P.</p>	

SERIES MC MANIFOLD PRESSURE REGULATORS

FLOW DIAGRAM

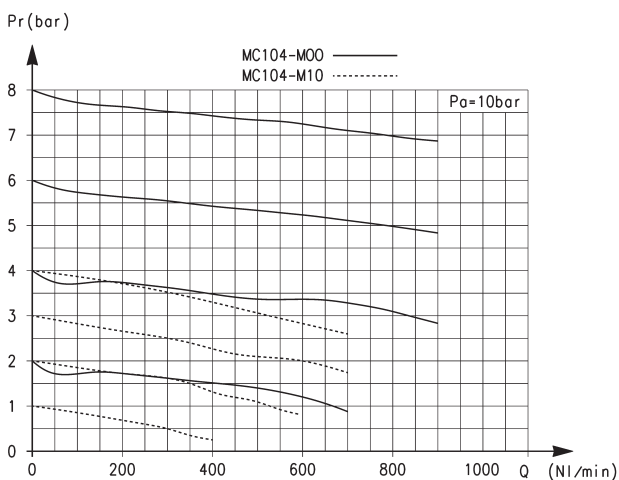

Flow diagram for model: MC104-M00

P_a = Inlet pressure (bar)

P_r = Regulated pressure (bar)

Q = Flow (NL/min)

Assembly

EXAMPLE BODY TYPE [H] :

Manifold regulator with through holes on top (used to mount the manifold regulators to each other).

N.B.: Once a group of manifolds has been assembled, it can be inserted in a FRL group. In this case the manifold regulator assembly alone would be defined as body type M.

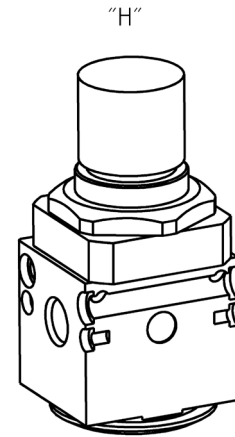

Assembly kits

- Kit A: 1 right flange + 1 left flange + 4 screws + 2 O-ring.
- Kit B: 2 brackets + 4 screws.
- Kit C: 2 tie rods male-female + 1 O-ring.
- Kit D: 2 tie rods female-female.
- Kit E: 2 male screws + 1 O-ring.
- Kit F: 2 male screws + 2 female screws + 1 O-ring.
- Kit G: 4 screws + 4 spacers + 2 O-ring, to be used on a body type "P" positioned between two body types "M".

N.B. for configurations which differ from the ones described, you can only add only bodies type "H" and for every part added you should add a Kit "C".

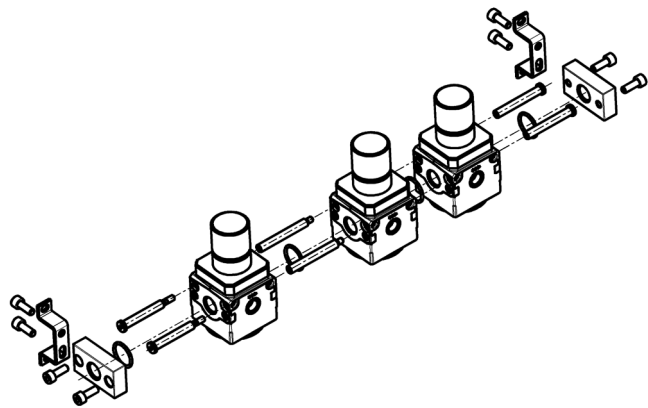

Manifold pressure regulators Series MC

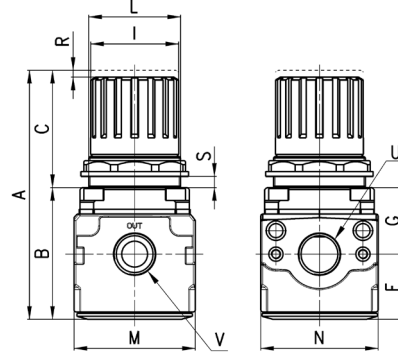

DIMENSIONS													
Mod.	A	B	C	F	G	I	L	M	N	R	S	U	V
MC104-M00	94	55	39	28	28	28	30X1,5	45	45	3	0÷6	G1/4	G1/8

Pneumatic symbols

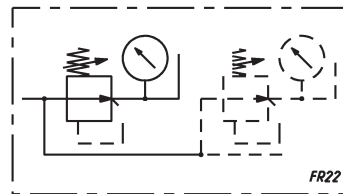
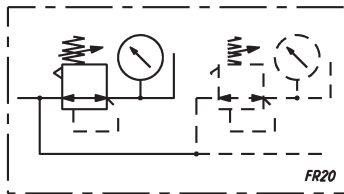
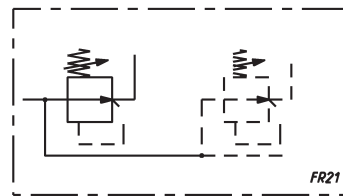
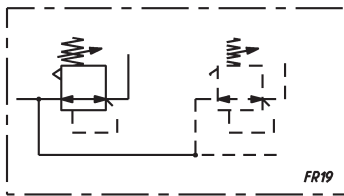

FR19 = Manifold regulator with relieving and without pressure gauge
FR20 = Manifold regulator with relieving and pressure gauge

FR21 = Manifold regulator without relieving and pressure gauge
FR22 = Manifold regulator without relieving and with pressure gauge