

Series MD pressure filter-regulators

Ports with interchangeable cartridges: threaded (1/8, 1/4, 3/8) or integrated with super-rapid fitting for tube with \varnothing 6, 8 and 10 mm

Modular assembly

Bowl with technopolymer cover and bayonet-type mounting



- » Filtering between 25 μm or 5 μm
- » Minimum pressure drops
- » Knob with position lock
- » Tamper-proof system (lockable regulator)
- » Bowl locking system reducing the risk of accidents

Series MD filter-regulators integrate filter and pressure reducer in one unit, thus reducing their dimensions.

The by-pass valve allows the fast exhaust of the air introduced. The different springs enable a more accurate adjustment of the pressure.

Thanks to the solution adopted for the pneumatic connection, it is possible to equip the same element with interchangeable cartridges that can either be threaded, or with an integrated super-rapid fitting, both types available in different sizes. Intermediate cartridges can be also integrated to join multiple functions or with derivation to draw air.

GENERAL DATA

Construction	modular, compact with filtering element in HDPE
Materials	see TABLE OF MATERIALS on the following page
Ports	with interchangeable cartridges: 1/8, 1/4 and 3/8 threaded or integrated with super-rapid fitting for tube with diameters of 6, 8 and 10 mm
Condensate capacity	24 cm ³
Mounting	in-line; wall-mounting by means of through holes in the body or with a support bracket; panel mounting
Operating temperature	-5°C ÷ 50°C up to 16 bar (with the dew point of the fluid lower than 2°C at the min. working temperature)
Condensate drain	semi-automatic manual, automatic, protected depressurisation, direct G1/8 exhaust
Quality of delivered air according to ISO 8573-1 2010	Class 6.8.4 with 5 μm filtering element Class 7.8.4 with 25 μm filtering element
Inlet pressure	0.3 ÷ 16 bar (with automatic drain 1 ÷ 9 bar)
Exit pressure	0.5 ÷ 2bar 0.5 ÷ 4bar 0.5 ÷ 7bar 0.5 ÷ 10bar
Nominal flow	see FLOW DIAGRAMS on the following pages
Fluid	compressed air

CODING EXAMPLE

MD	1	-	FR	0	0	0	0	-	1/8
-----------	----------	----------	-----------	----------	----------	----------	----------	----------	------------

MD	SERIES
1	DIMENSION: 1 = 42 mm
FR	FILTER-REGULATOR
0	FILTERING ELEMENT (further details in the dedicated section) AND DESIGN TYPE: 0 = 25 µm with relieving 1 = 5 µm with relieving 2 = 25 µm without relieving * 3 = 5 µm without relieving * 4 = 25 µm with relieving and by-pass valve 5 = 5 µm with relieving and by-pass valve 6 = 25 µm without relieving, with by-pass valve * 7 = 5 µm without relieving, with by-pass valve * * this option is available with semiautomatic-manual drain only
0	DRAINING OF CONDENSATE (further details in the dedicated section): 0 = semiautomatic-manual drain 3 = automatic drain 5 = protected depressurisation 8 = direct G1/8 exhaust
0	OPERATING PRESSURE (1 bar = 14,5 psi): 0 = 0.5 ÷ 10 bar 2 = 0.5 ÷ 2 bar 4 = 0.5 ÷ 4 bar 7 = 0.5 ÷ 7 bar
0	PRESSURE GAUGE: 0 = without pressure gauge (with 1/8 port)
1/8	PORTS (IN - OUT)*: = without cartridges 1/8 = G1/8 1/4 = G1/4 3/8 = G3/8 6 = tube Ø6 8 = tube Ø8 10 = tube Ø10 * NOTE: if the inlet (IN) cartridge is different from the outlet (OUT) cartridge, both dimensions shall be indicated. Example: MD1-FR0000-1/4-1/8

SERIES MD FILTER-REGULATORS

Series MD filter-regulators - materials

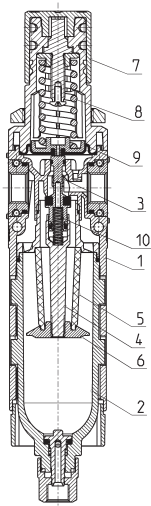

PARTS	MATERIALS
1 = Body	Polyamide
2 = Tank	Polycarbonate
3 = Poppet	Brass
4 = Valve guide	Polyacetal
5 = Filtering element	Polyethylene
6 = Separation deflector	Polyacetal
7 = Knob	Polyamide
8 = Upper spring	Zinc-plated steel
9 = Diaphragm	NBR
10 = Lower spring	Stainless steel
Seals	NBR

FLOW DIAGRAMS

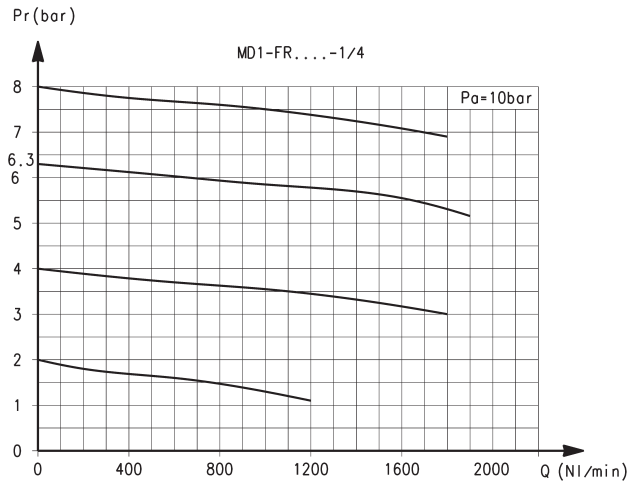
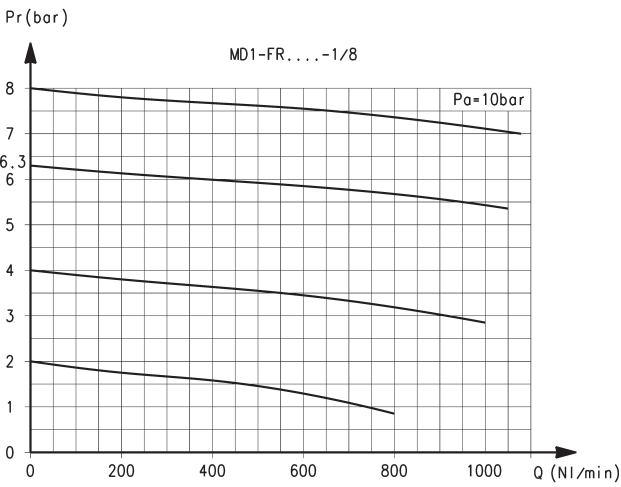

Ports with interchangeable G1/8 threaded cartridges

Pr = Regulated pressure (bar)
Q = Flow (NL/min)

Pa = Inlet pressure (bar)

Ports with interchangeable G1/4 threaded cartridges

Pr = Regulated pressure (bar)
Q = Flow (NL/min)

Pa = Inlet pressure (bar)

FLOW DIAGRAM

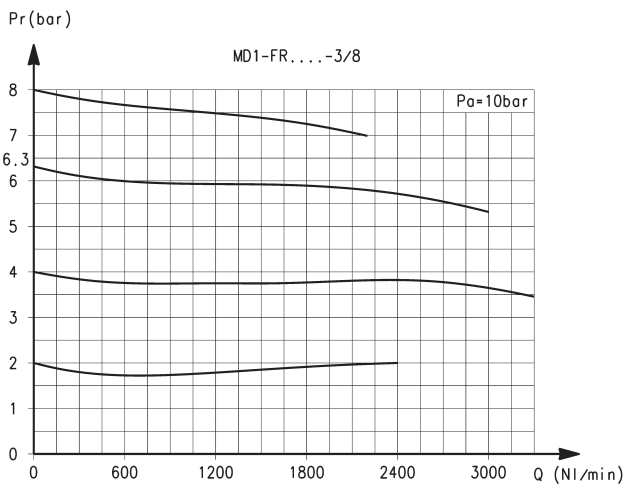

Ports with interchangeable G3/8 threaded cartridges

Pr = Regulated pressure (bar)
Q = Flow (NL/min)

Pa = Inlet pressure (bar)

N.B: The version with automatic exhaust has a flow reduction of max 10%

PNEUMATIC SYMBOLS

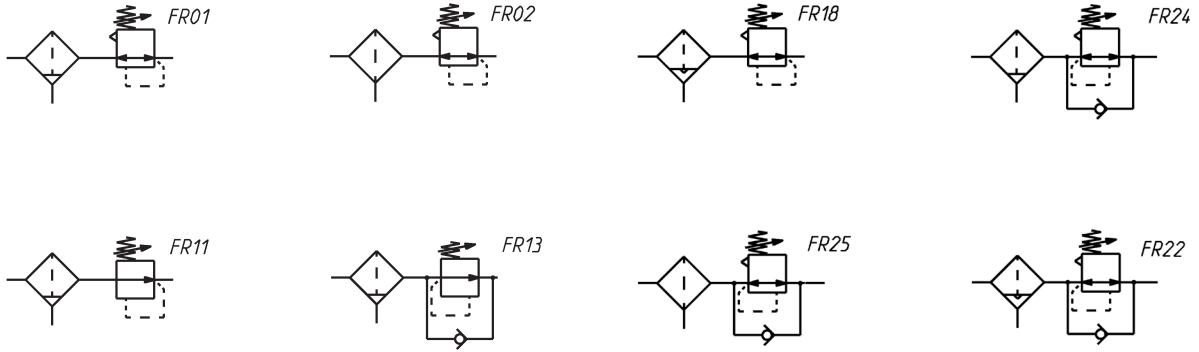

FR01 = filter-regulator with relieving and semi-automatic manual drain
 FR02 = filter-regulator with relieving and direct G1/8 exhaust
 FR11 = filter-regulator without relieving, with semi-automatic manual drain
 FR13 = filter-regulator without relieving, with by-pass valve and semi-automatic manual drain

FR18 = filter-regulator with relieving and automatic/depressuring drain
 FR24 = filter-regulator with relieving, by-pass valve and semi-automatic manual drain
 FR25 = filter-regulator with relieving, by-pass valve and direct G1/8 exhaust
 FR22 = filter-regulator with relieving, by-pass valve and automatic/depressuring drain

SERIES MD FILTER-REGULATORS

Series MD filter-regulators - dimensions

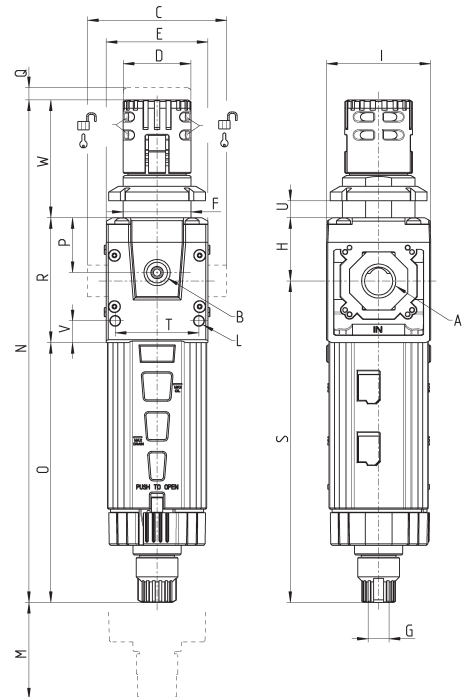

Mod.	A	B	C	D	E	F	G	H	I	L	M	N	P	Q	R	S	T	U	V	W	Peso (Kg)
MD1-FR0000	-	G1/8	42	Ø28	42	M28X1,5	G1/8	26.2	43	Ø4	110	208.2	22.7	4	51.7	133.2	34.6	0 ÷ 11	9	48.8	0.2
MD1-FR0000-1/8	G1/8	G1/8	42	Ø28	42	M28X1,5	G1/8	26.2	43	Ø4	110	208.2	22.7	4	51.7	133.2	34.6	0 ÷ 11	9	48.8	0.2
MD1-FR0000-1/4	G1/4	G1/8	42	Ø28	42	M28X1,5	G1/8	26.2	43	Ø4	110	208.2	22.7	4	51.7	133.2	34.6	0 ÷ 11	9	48.8	0.2
MD1-FR0000-3/8	G3/8	G1/8	42	Ø28	42	M28X1,5	G1/8	26.2	43	Ø4	110	208.2	22.7	4	51.7	133.2	34.6	0 ÷ 11	9	48.8	0.2
MD1-FR0000-6	Ø6	G1/8	47	Ø28	42	M28X1,5	G1/8	26.2	43	Ø4	110	208.2	22.7	4	51.7	133.2	34.6	0 ÷ 11	9	48.8	0.2
MD1-FR0000-8	Ø8	G1/8	62	Ø28	42	M28X1,5	G1/8	26.2	43	Ø4	110	208.2	22.7	4	51.7	133.2	34.6	0 ÷ 11	9	48.8	0.2
MD1-FR0000-10	Ø10	G1/8	67	Ø28	42	M28X1,5	G1/8	26.2	43	Ø4	110	208.2	22.7	4	51.7	133.2	34.6	0 ÷ 11	9	48.8	0.2
MD1-FR0000	-	G1/8	42	Ø28	42	M28X1,5	M10x1	26.2	43	Ø4	110	197.6	22.7	4	51.7	122.9	34.6	0 ÷ 11	9	48.8	0.2