

Pneumatic mini slides Series MSN

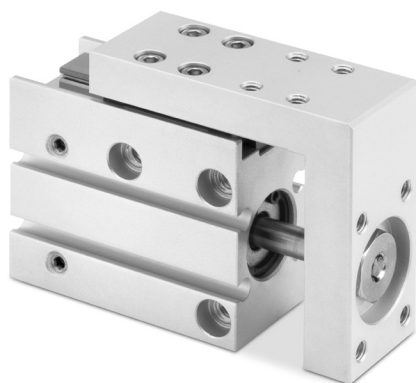

Size: 6, 10, 16, 20



- » Compact and light design
- » High positioning precision
- » Integrated rubber buffer

The mini-slides Series MSN are an optimum solution for quick and accurate movements, especially suitable for the pick & place and inserting applications common in the assembly and secondary packaging sector.

This series is available in 4 sizes, composed of a combination of a pneumatic cylinder and a precision ball bearing guide and is ideal for applications requiring a high movement frequency.

Equipped with an internal magnet, proximity switches can be integrated to enable position monitoring. Their compact and light design makes the mini-slides Series MSN ideal to be used in narrow spaces and in industrial applications that require high flexibility in the movement of loads.

GENERAL DATA

Operation	double-acting
Strokes min. max	see table
Operating temperature	5°C ÷ 60°C (with dry air - 20°C)
Speed	50 ÷ 500 mm/s
Operating pressure	1.5 ÷ 7 bar
Fluid	filtered air in class 7.8.4 according to ISO 8573-1 standard. If lubricated air is used, it is recommended to use oil ISOVG32. Once applied the lubrication should never be interrupted.
Sensors	CSD

STANDARD STROKES

■ = Double-acting

STANDARD STROKES										
Mod.	∅	5	10	15	20	25	30	40	50	60
MSN6	6	■	■	■	■	■	■			
MSN10	10	■	■	■	■	■	■	■	■	
MSN16	16	■	■	■	■	■	■	■	■	■
MSN20	20	■	■	■	■	■	■	■	■	■

CODING EXAMPLE

MSN	10	-	30
------------	-----------	---	-----------

MSN	SERIES
10	SIZE: 6 10 16 20
30	STROKE: (See the standard strokes table)

PNEUMATIC SYMBOLS

The pneumatic symbols which have been indicated in the CODING EXAMPLE are shown below.

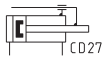

Pneumatic mini slides Series MSN - construction

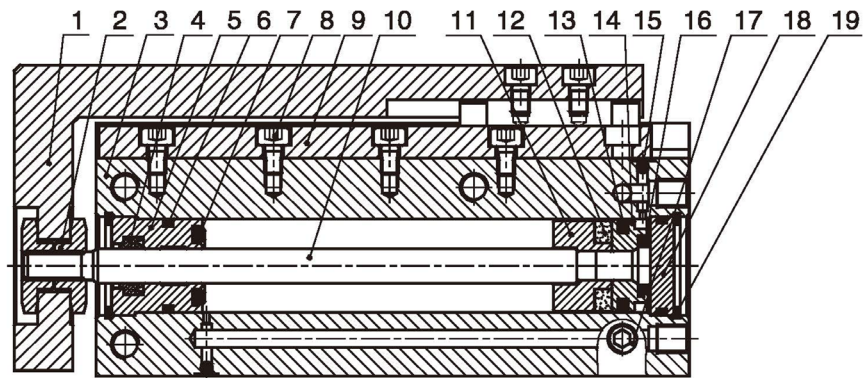

LIST OF COMPONENTS			
PARTS	MATERIALS	PARTS	MATERIALS
1 - Slide table	Aluminum Alloy	11 - Magnet Seat	Aluminum Alloy
2 - Locknut	Carbon steel	12 - Magnet	Neodymium iron boron
3 - Body	Aluminum Alloy	13 - Piston Seal	NBR
4 - Front Sreaper Seal	NBR	14 - Piston	Aluminum Alloy
5 - Head cover	Aluminum Alloy	15 - Steel ball	Stainless steel
6 - O-ring	NBR	16 - Bumper	TPU
7 - Bumper	TPU	17 - Plug	Cu
8 - Screws	Carbon steel	18 - Rear cover	Aluminum Alloy
9 - Linear ball slide rail	Stainless steel	19 - C clip	Spring steel
10 - Piston rod	Stainless steel		

Weights

Unit of measurement: g

The weight in the table below is the standard product weight without adjuster.

Stroke (mm)	5	10	15	20	25	30	40	50	60
Mod.									
MSN6	56	62	749	809	80	93	-	-	-
MSN10	126	112	126	134	128,5	146	156	170	-
MSN16	178	215	230	245	248	264,5	294,5	315,5	344,5
MSN20	301	346	371	396	411	436	485	531	581,5

Theoretical power

Unit of measurement: N

Mod.	Bore size (mm)	Rod size (mm)	Acting type	Area (mm ²)	1 bar	2 bar	3 bar	4 bar	5 bar	6 bar	7 bar	
MSN6	6	3	Double acting	Push-side	28.3	-	5.7	8.5	11.3	14.2	17.0	19.8
				Pull-side	21.2	-	4.2	6.4	8.5	10.6	12.7	14.8
MSN10	10	4	Double acting	Push-side	78.5	7.9	15.7	23.6	31.4	39.3	47.1	55.0
				Pull-side	66.0	6.6	13.2	19.8	26.4	33.0	39.6	46.2
MSN16	16	6	Double acting	Push-side	201.0	20.1	40.2	60.3	80.4	100.5	120.6	140.7
				Pull-side	172.7	17.3	34.5	51.8	69.1	86.4	103.6	120.9
MSN20	20	8	Double acting	Push-side	314.0	31.4	62.8	94.2	125.6	157.0	188.4	219.8
				Pull-side	263.8	26.4	52.8	79.1	105.5	131.9	158.3	184.7

Model Selection

The choice of the slide model must be made according to the following procedure.

By knowing the assembly conditions, see the corresponding section to establish the appropriate slide model for your application.

Model Selection Method (vertical)

By knowing the operating conditions, follow this procedure:

- 1) Choose the graph according to the motion speed of the load.
- 2) By using the selected graph, find the intersection between the mass m of the load and the arm L . As a result you will obtain the size of the slide to use.
- 3) If the selected point is not on one of the curves shown in the graph, choose the next size or change the operating parameters and repeat the described procedure.

m = mass of the load [kg]

L = load arm, distance from the axis of the slide rod to the centre of gravity of the applied load [mm].

H = distance from the axis of the slide rod to the surface of the table on which the load is mounted [mm].

g = acceleration of gravity = 9.81 m/s^2

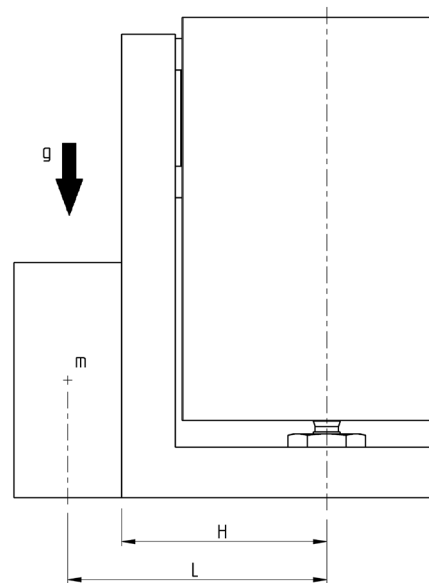

	MSN6	MSN10	MSN16	MSN20
Dimension (H)	24.5	30.5	34.5	41.5

Selection graph (vertical)

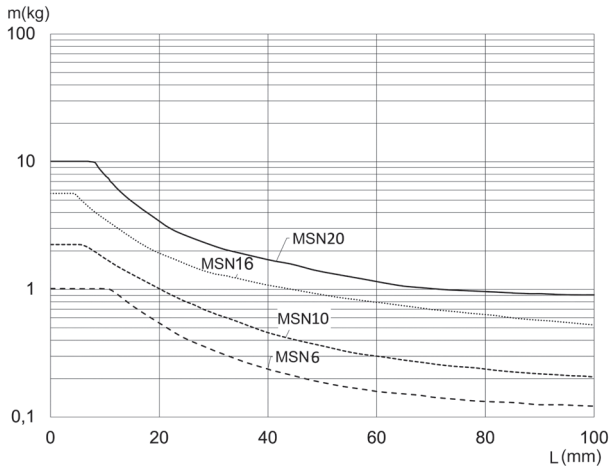

(1)
Maximum speed: ≤ 100 mm/s

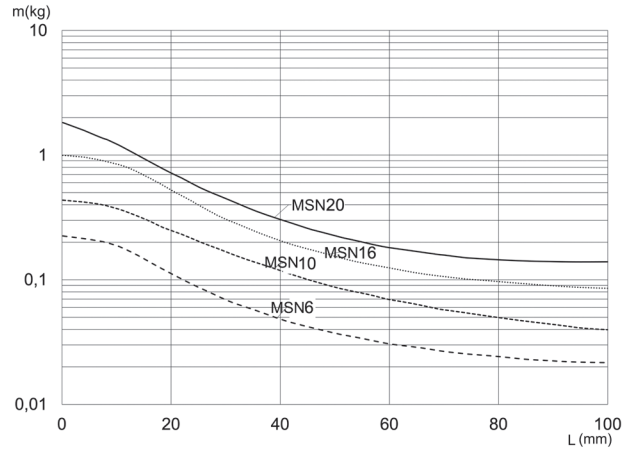

(2)
Maximum speed: ≤ 300 mm/s

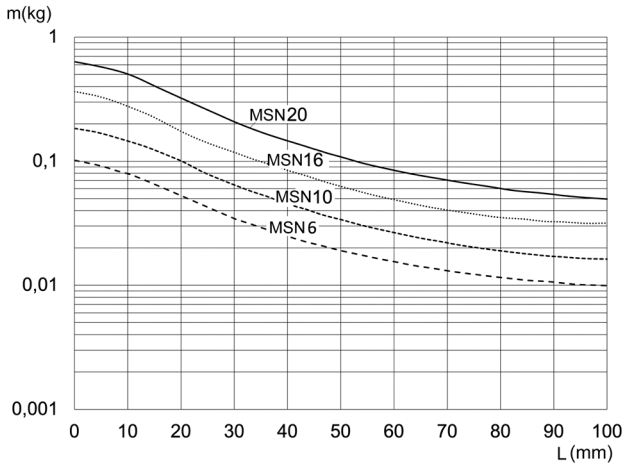

(3)
Maximum speed: ≤ 500 mm/s

Model Selection Method (horizontal)

By knowing the operating conditions, follow this procedure:

- 1) Choose the graph according to the motion speed and the eccentricity of load L1.
- 2) By using the selected graph, find the intersection between the mass m of the load and the arm L . As a result you will obtain the size of the slide to use.
- 3) If the selected point is not on one of the curves shown in the graph, choose the next size or change the operating parameters and repeat the described procedure.

m = mass of the load [kg]
 L = load arm, distance from the axis of the slide rod to the centre of gravity of the applied load [mm].
 H = distance from the axis of the slide rod to the surface of the table on which the load is mounted [mm].
 g = acceleration of gravity = 9.81 m/s^2

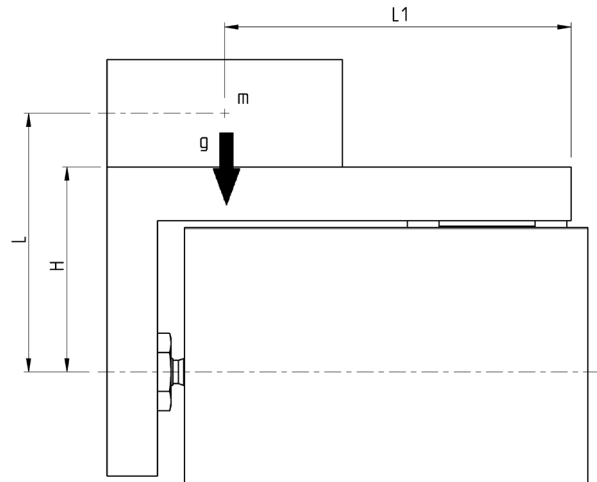

PNEUMATIC MINI SLIDES SERIES MSN

	MSN6	MSN10	MSN16	MSN20
Dimension (H)	24.5	30.5	34.5	41.5

Selection graph (horizontal)

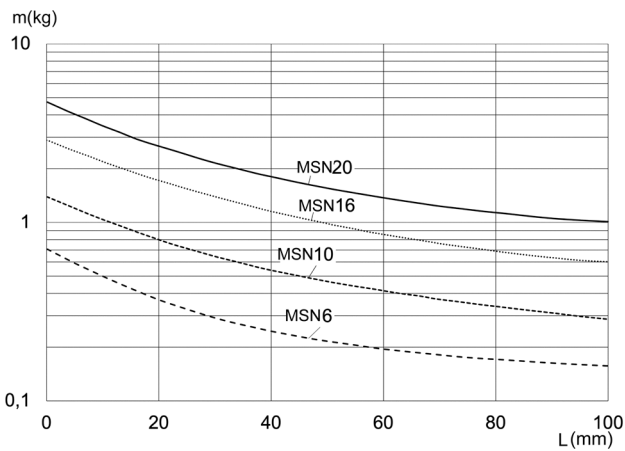

(4)
 Maximum speed: $\leq 100 \text{ mm/s}$
 Load eccentricity: 50 mm

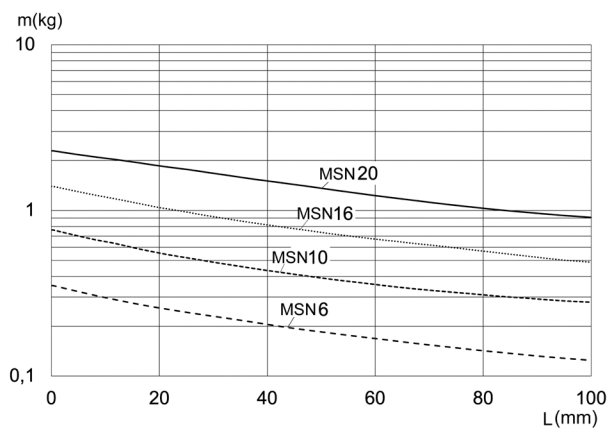

(5)
 Maximum speed: $\leq 100 \text{ mm/s}$
 Load eccentricity: 100 mm

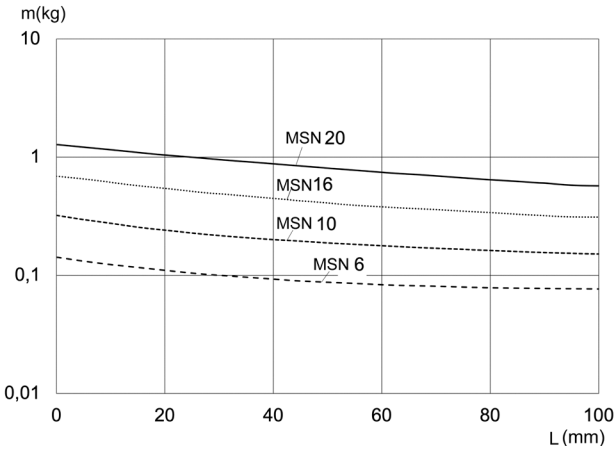

(6)
Maximum speed: $\le 100\text{ mm/s}$
Load eccentricity: 200 mm

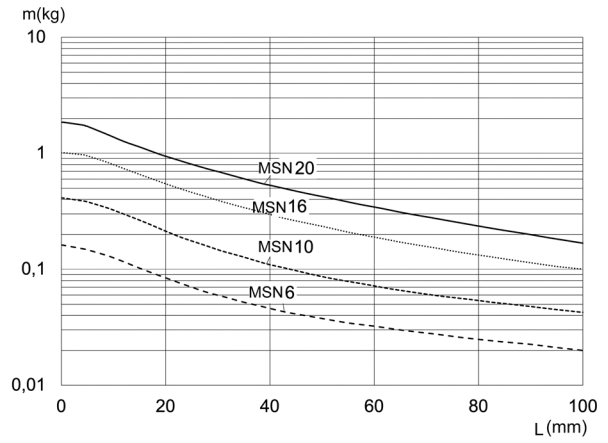

(7)
Maximum speed: $\le 300\text{ mm/s}$
Load eccentricity: 50 mm

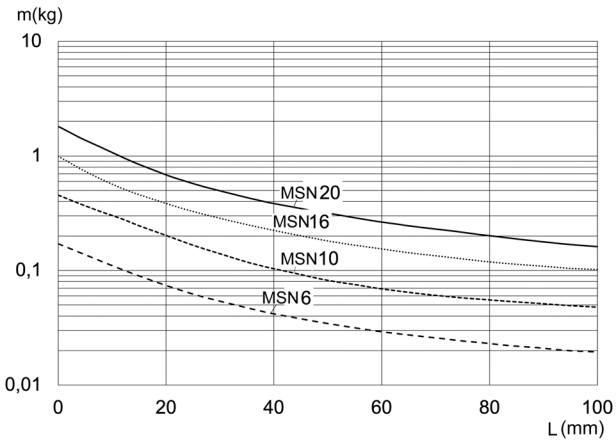

(8)
Maximum speed: $\le 300\text{ mm/s}$
Load eccentricity: 100 mm

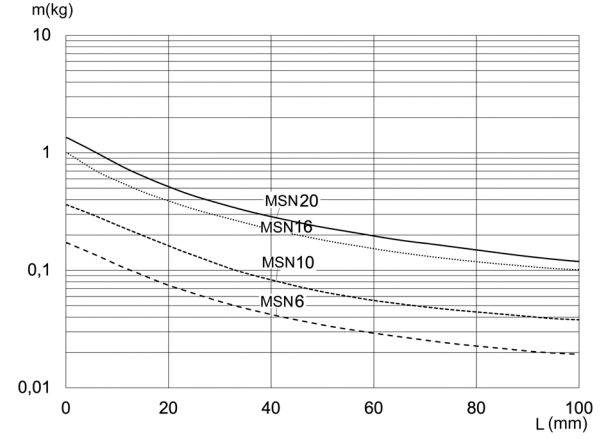

(9)
Maximum speed: $\le 300\text{ mm/s}$
Load eccentricity: 200 mm

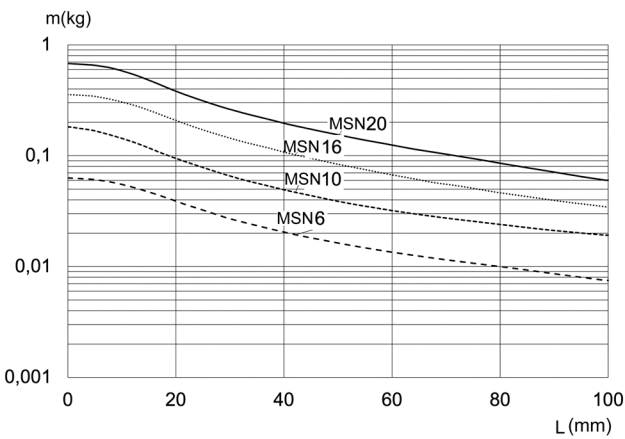

(10)
Maximum speed: $\le 500\text{ mm/s}$
Load eccentricity: 50 mm

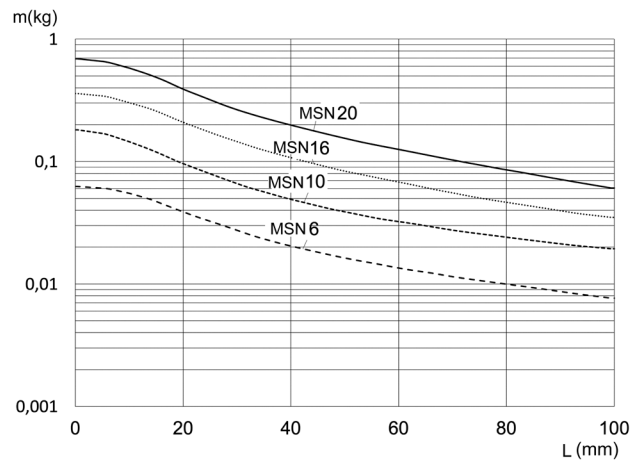

(11)
Maximum speed: $\le 500\text{ mm/s}$
Load eccentricity: 100 mm

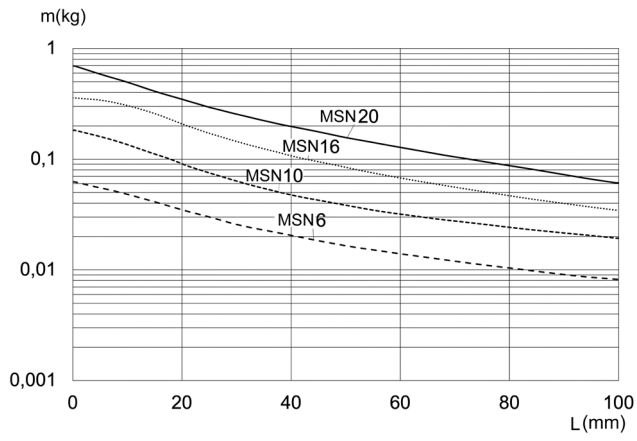

(12)
 Maximum speed: ≤500 mm/s
 Load eccentricity: 200 mm

Table of permissible moments

The actual loading and torque of mini slides must be less than its allowable loading and torque:

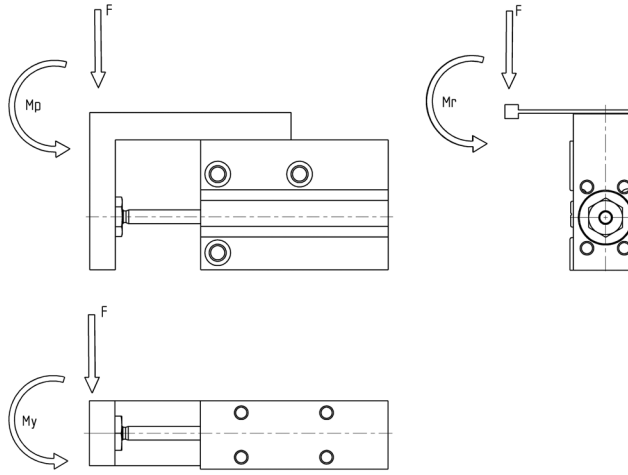

STROKE			
Mod.	Mp (Nm)	My (Nm)	Mr (Nm)
MSN6	0.25	0.25	0.41
MSN10	0.95	0.95	1.49
MSN16	3.28	3.28	3.45
MSN20	6.29	6.29	6.61

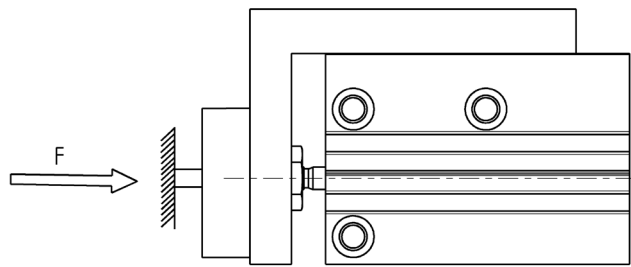

1. Graphs deflection

Below are the graphs of table deflection, divided according to the type of acting moment.
By knowing the value of the moment and the slide model, check that the table deflection is appropriate for the required application.

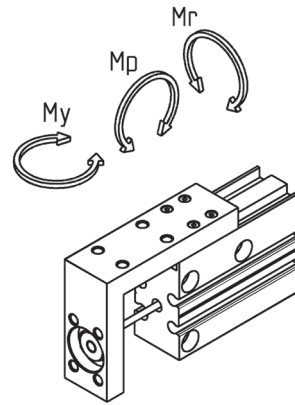

1.1 Graphs deflection due to Mp Moment

Graphs deflection (arrow) when a load acts upon the section marked with the arrow at the full stroke of the compact slide

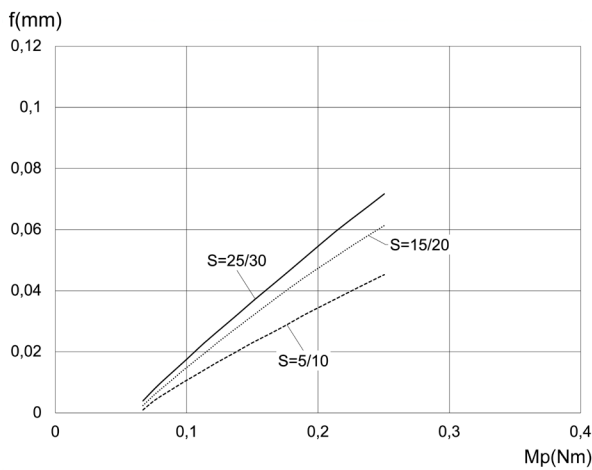
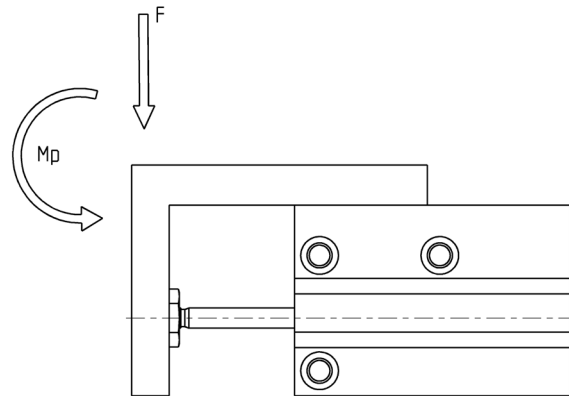

MSN6

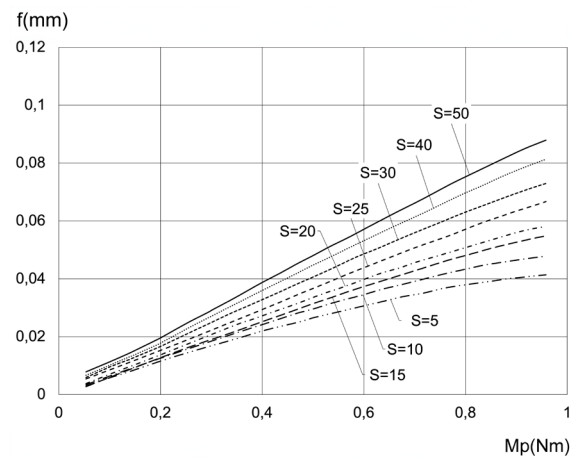

MSN10

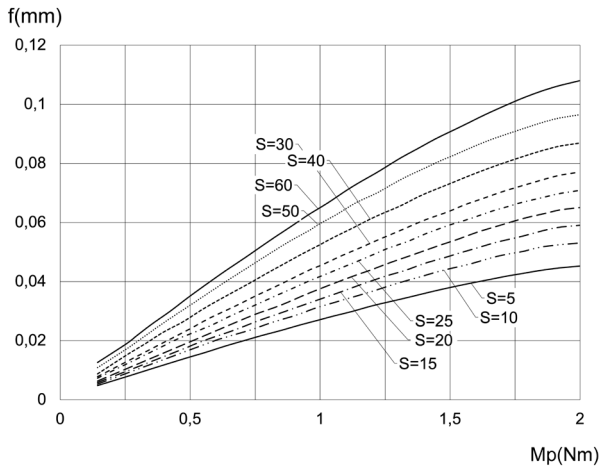

MSN16

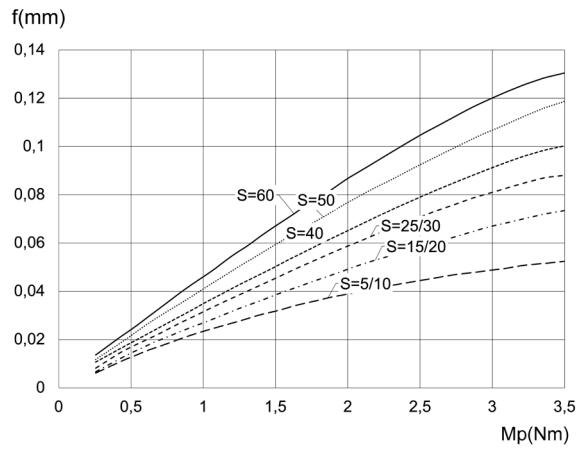

MSN20

1.2 Graphs deflection due to My Moment

Graphs deflection (arrow) when a load acts upon the section marked with the arrow at the full stroke of the compact slide

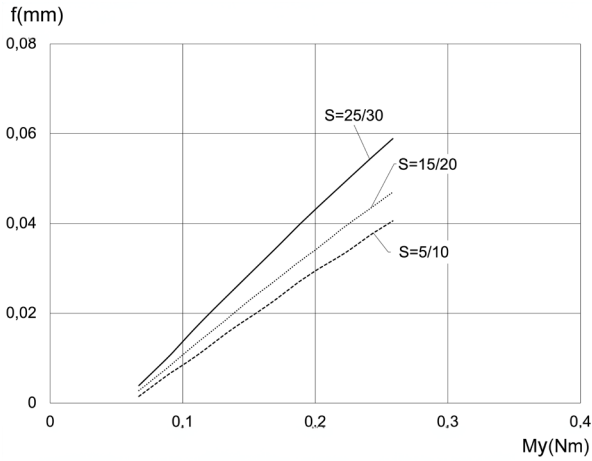
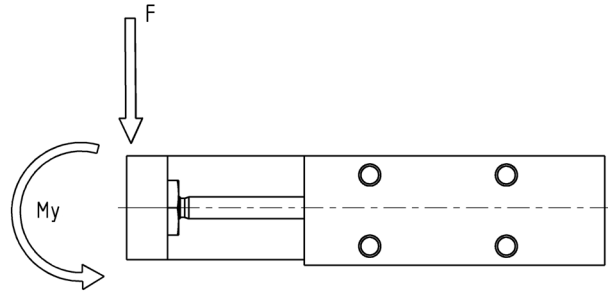

MSN6

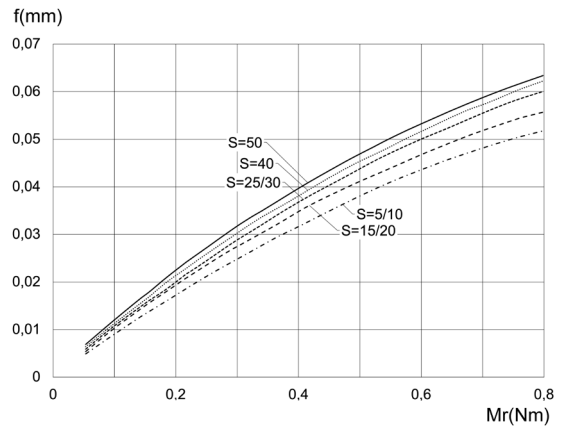

MSN10

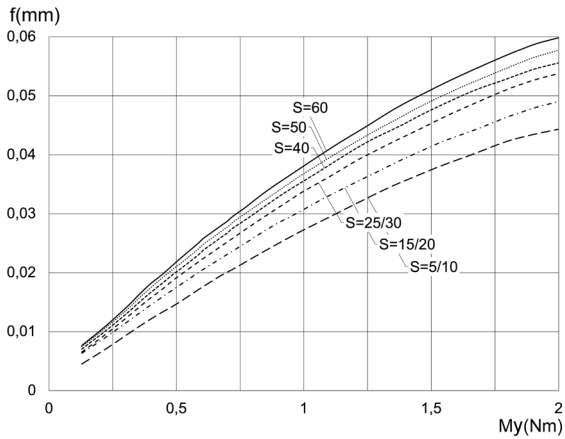

MSN16

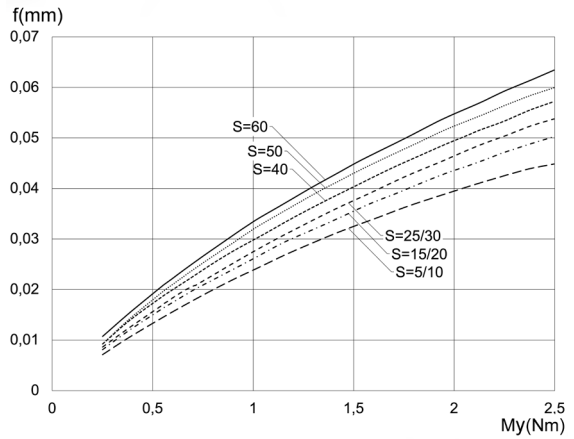

MSN20

1.3 Graphs deflection due to Mr Moment

Graphs deflection (at A) when a load acts upon the section F at the full stroke of the compact slide.

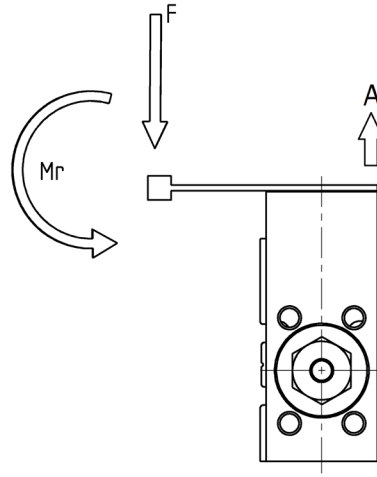

PNEUMATIC MINI SLIDES SERIES MSN

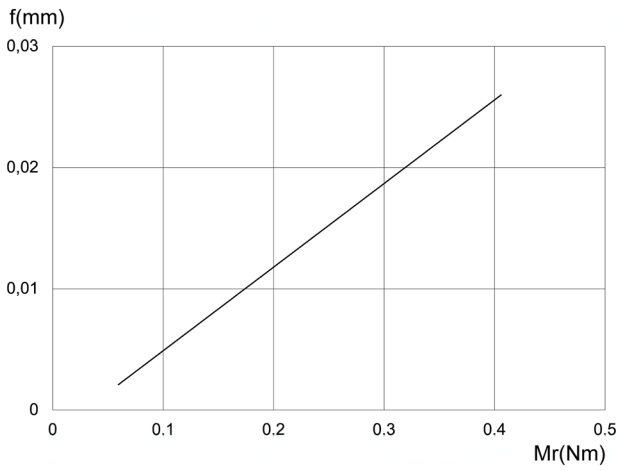

MSN6

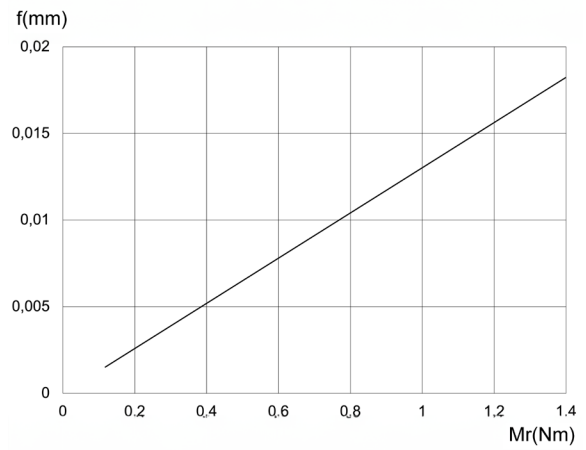

MSN10

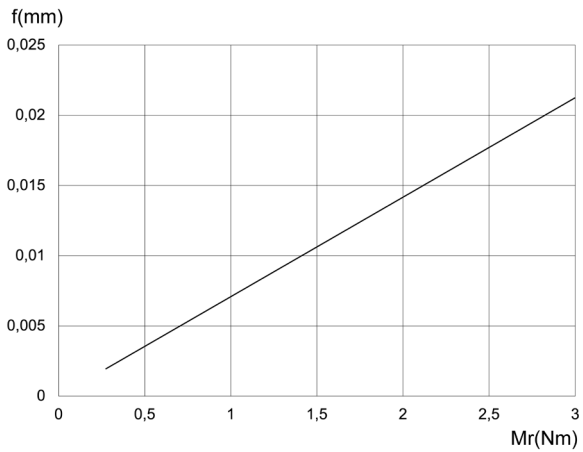

MSN16

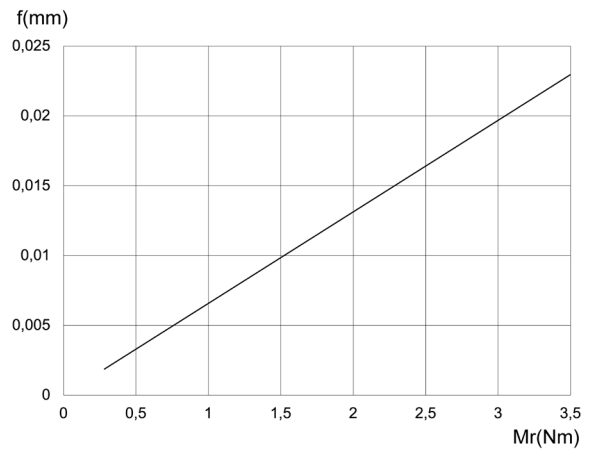

MSN20

Examples of mounting

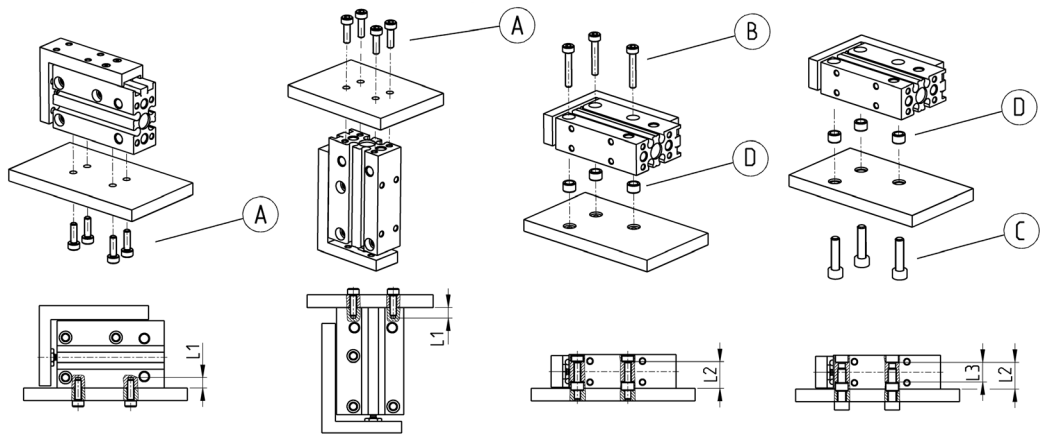

Mod.	A	B	C	D	L1 (mm)	L2 (mm)	L3 (mm)
MSN6	M3	M3	M4	Ø6	5	12,7	9,4
MSN10	M4	M4	M5	Ø7,5	6	15,6	11,2
MSN16	M4	M4	M5	Ø7,5	6	20,6	16,2
MSN20	M5	M5	M6	Ø9,3	8	24	16

Examples of mounting

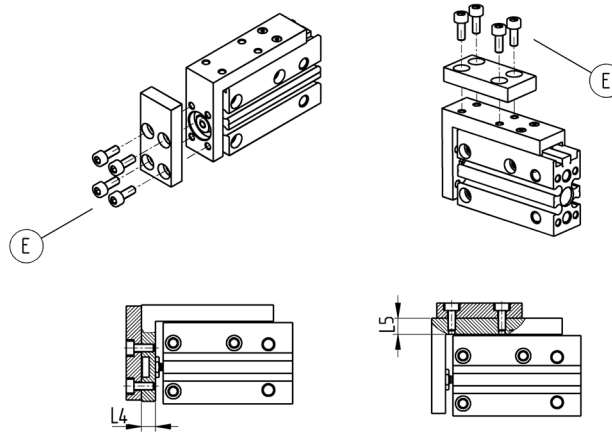

Mod.	E	L4 (mm)	L5 (mm)
MSN6	M3	5,5	6,5
MSN10	M4	7,5	8
MST16	M4	10	9
MST20	M5	11	9,5

Example of mounting: sensors

Series CSD

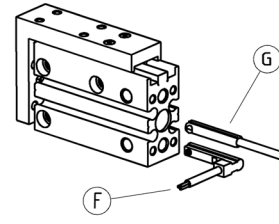

Mod.
F = CSD-H-334 CSD-H-364
G = CSD-D-334 CSD-D-364

Air supply ports

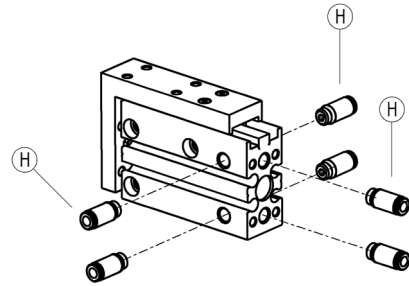

Mod.	H
MSN6	M5
MSN10	M5
MSN16	M5
MSN20	M5

Pneumatic mini slides Series MSN

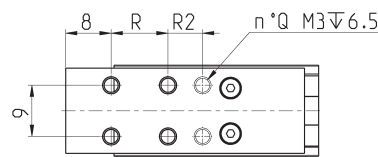
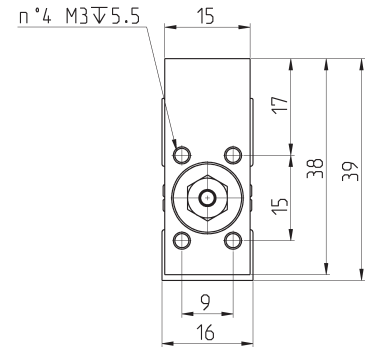
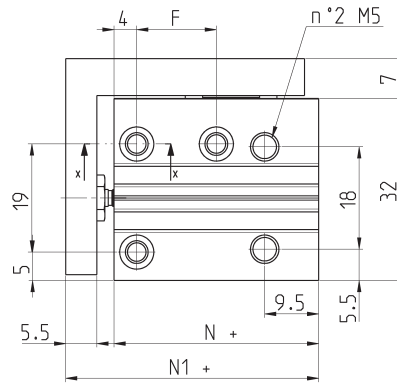
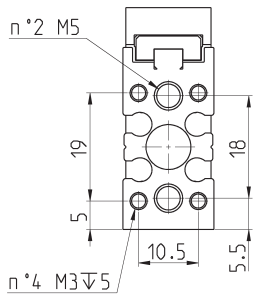
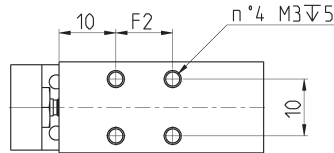
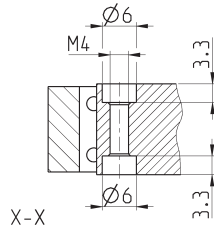

Mod.	F2	F	R	R2	E	N+	N1+	Q
MSN6-5	10	14	10	-	42	36	44,5	4
MSN6-10	15	14	10	-	42	41	49,5	4
MSN6-15	20	24	20	-	52	46	54,5	4
MSN6-20	25	24	20	-	52	51	59,5	4
MSN6-25	30	30	30	-	62	56	64,5	4
MSN6-30	35	30	30	-	62	61	69,5	4
MSN6-40	45	45	20	20	72	71	79,5	6

Pneumatic mini slides Series MSN

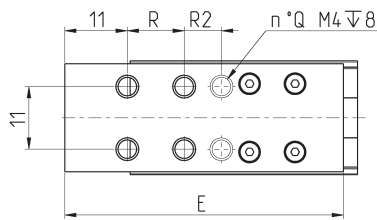
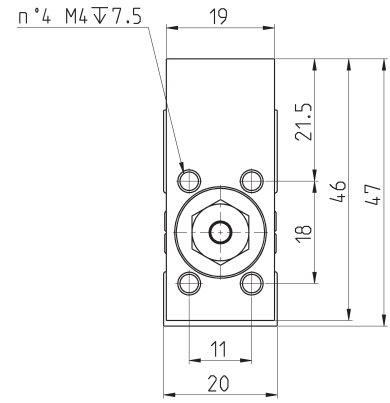
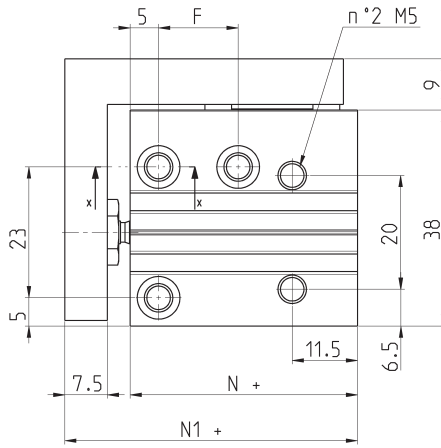
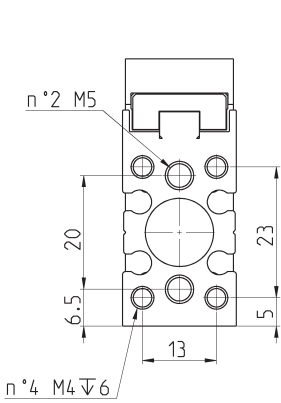
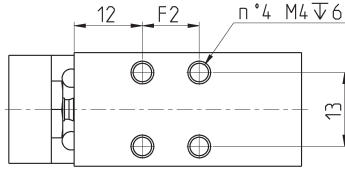
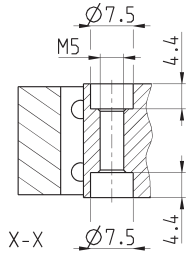

Mod.	F2	F	R	R2	E	N+	N1+	Q
MSN10-5	10	14	10	-	49	40	51.5	4
MSN10-10	15	14	10	-	49	45	56.5	4
MSN10-15	20	24	20	-	59	50	61.5	4
MSN10-20	25	24	20	-	59	55	66.5	4
MSN10-25	30	30	30	-	69	60	71.5	4
MSN10-30	35	30	30	-	69	65	76.5	4
MSN10-40	45	45	20	20	79	75	86.5	6
MSN10-50	55	55	25	25	89	85	96.5	6

Pneumatic mini slides Series MSN

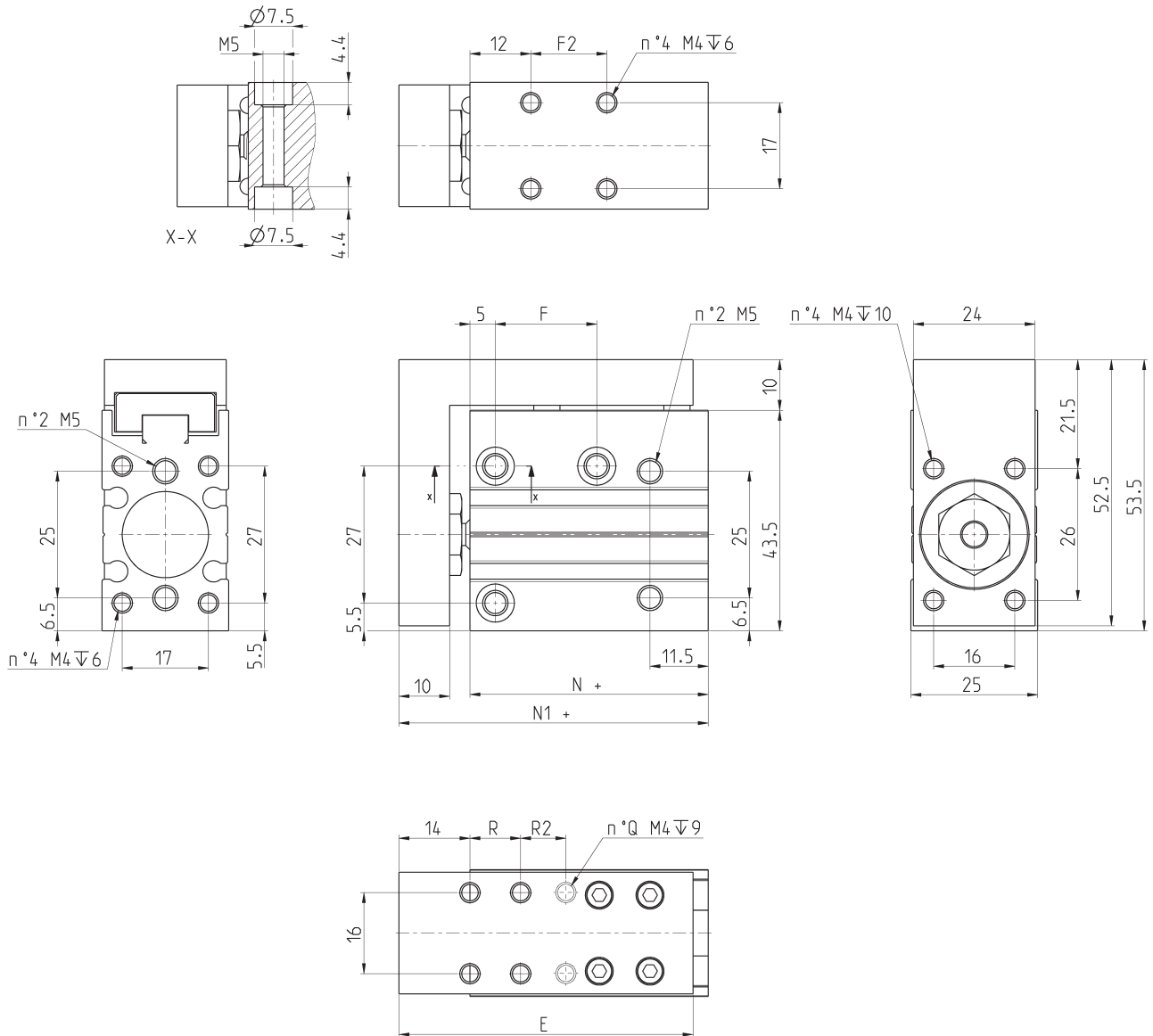

Mod.	F2	F	R	R2	E	N+	N1+	Q
MSN16-5	15	20	10	-	58	47	61	4
MSN16-10	20	20	10	-	58	52	66	4
MSN16-15	25	30	20	-	68	57	71	4
MSN16-20	30	30	20	-	68	62	76	4
MSN16-25	35	40	30	-	78	67	81	4
MSN16-30	40	40	30	-	78	72	86	4
MSN16-40	50	50	20	20	88	82	96	6
MSN16-50	60	60	25	25	98	92	106	6
MSN16-60	70	60	30	30	108	102	116	6

Pneumatic mini slides Series MSN



PNEUMATIC MINI SLIDES SERIES MSN

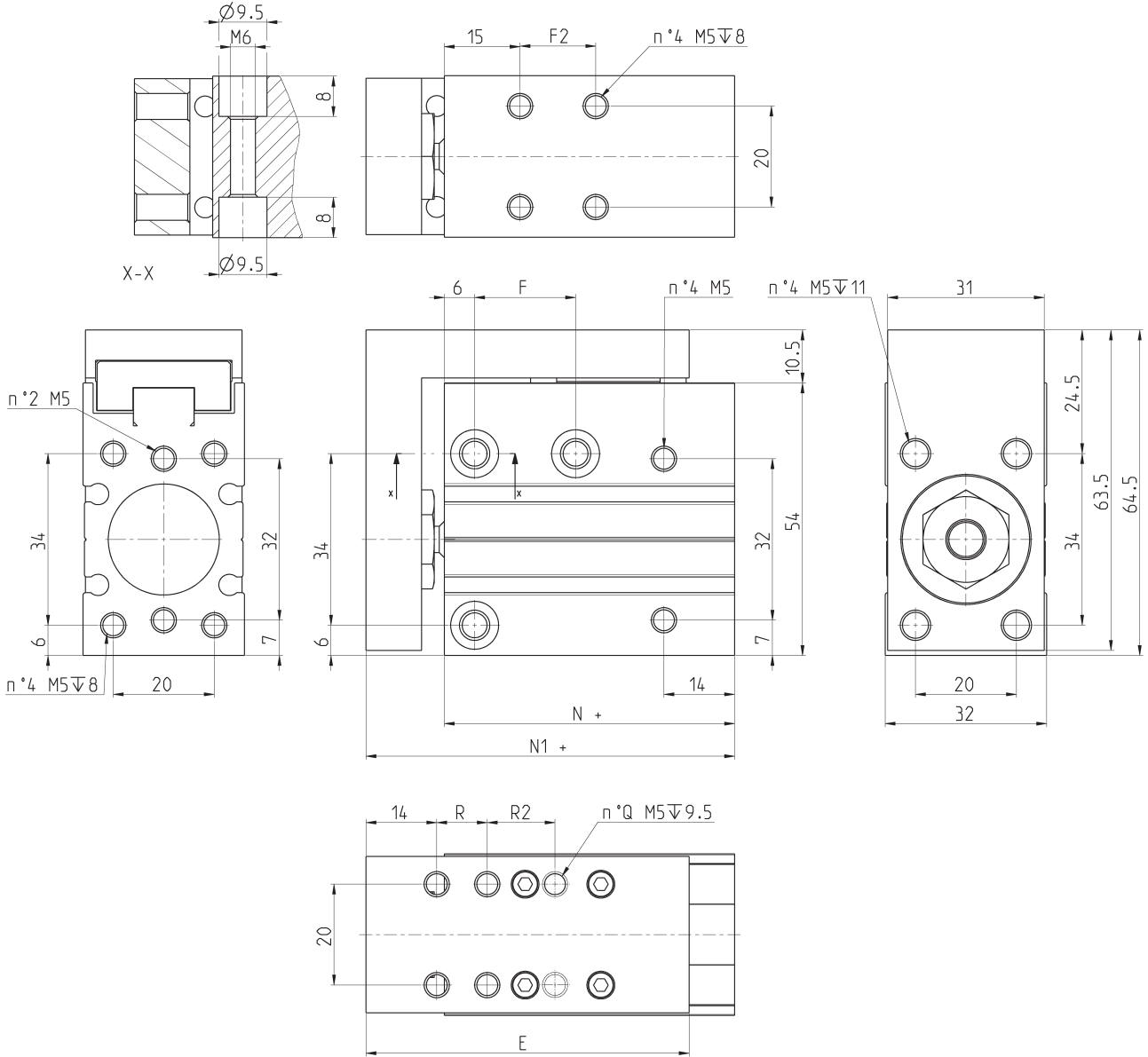

Mod.	F2	F	R	R2	E	N+	N1+	Q
MSN20-5	15	20	10	-	64	57.5	73	4
MSN20-10	20	20	10	-	64	62.5	78	4
MSN20-15	25	25	20	-	74	67.5	83	4
MSN20-20	30	25	20	-	74	72.5	88	4
MSN20-25	35	40	30	-	84	77.5	93	4
MSN20-30	40	40	30	-	84	82.5	98	4
MSN20-40	50	50	20	20	94	92.5	108	6
MSN20-50	60	70	25	25	104	102.5	118	6
MSN20-60	70	70	30	30	114	112.5	128	6

Magnetic proximity switches, 3-wire cable, D-slot

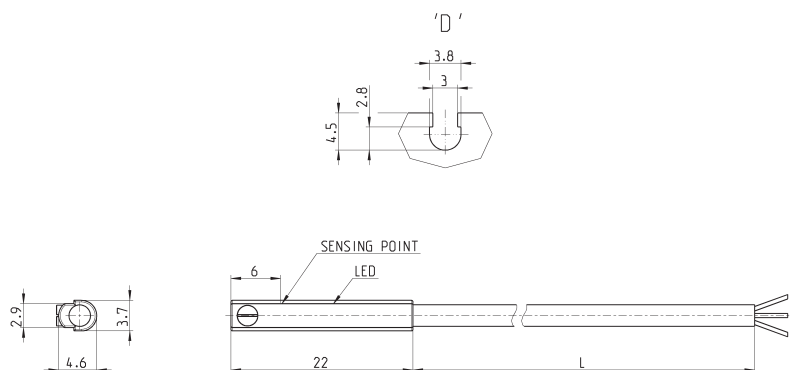

Mod.	Operation	Connections	Voltage	Output	Max. current	Max Load	Protection	L = length cable
CSD-D-334	Magneto-resistive	3 wires	10 ÷ 27 V DC	PNP	200 mA	6W	Against polarity reversing and overvoltage	2 m
CSD-D-334-5	Magneto-resistive	3 wires	10 ÷ 27 V DC	PNP	200 mA	6W	Against polarity reversing and overvoltage	5 m
CSD-D-374	Magneto-resistive	3 wires	10 ÷ 27 V DC	NPN	200 mA	6W	Against polarity reversing and overvoltage	2 m
CSD-D-374-5	Magneto-resistive	3 wires	10 ÷ 27 V DC	NPN	200 mA	6W	Against polarity reversing and overvoltage	5 m

Magnetic proximity switches, 3-wire cable, D-slot with 90° cable

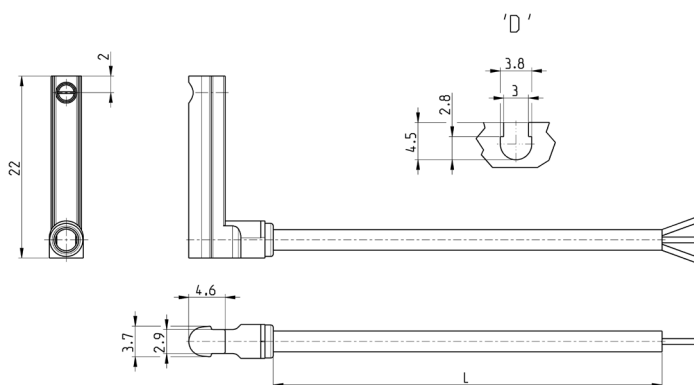

Mod.	Operation	Connections	Voltage	Output	Max. current	Max Load	Protection	L = length cable
CSD-H-334	Magneto-resistive	3 wires	10 ÷ 27 V DC	PNP	200 mA	6W	Against polarity reversing and overvoltage	2 m
CSD-H-334-5	Magneto-resistive	3 wires	10 ÷ 27 V DC	PNP	200 mA	6W	Against polarity reversing and overvoltage	5 m
CSD-H-374	Magneto-resistive	3 wires	10 ÷ 27 V DC	NPN	200 mA	6W	Against polarity reversing and overvoltage	2 m
CSD-H-374-5	Magneto-resistive	3 wires	10 ÷ 27 V DC	NPN	200 mA	6W	Against polarity reversing and overvoltage	5 m

Magnetic proximity switches, male M8 3-pin conn., D-slot, straight



Cable length: 0.3 m

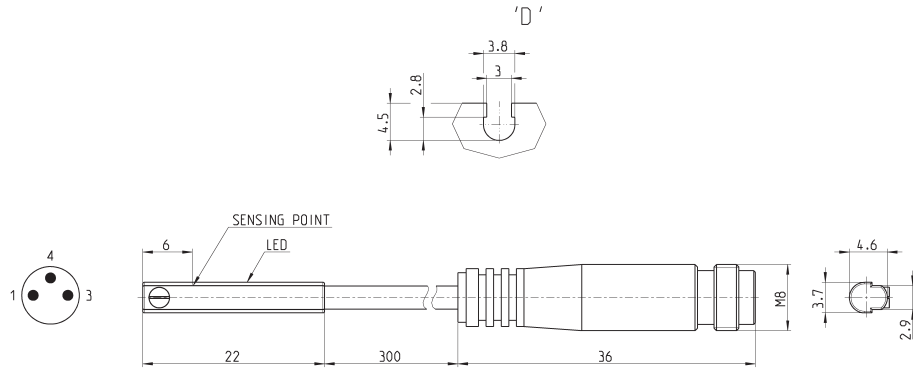

Mod.	Operation	Connection	Voltage	Output	Max current	Max load	Protection
CSD-D-364	Magneto-resistive	3 wires with M8 connector	10 ÷ 27 V DC	PNP	200 mA	6 W	Against polarity reversing and overvoltage
CSD-D-384	Magneto-resistive	3 wires with M8 connector	10 ÷ 27 V DC	NPN	200 mA	6 W	Against polarity reversing and overvoltage

Magnetic proximity switches, male M8 3-pin conn., D-slot, 90°



Cable length: 0.3 m

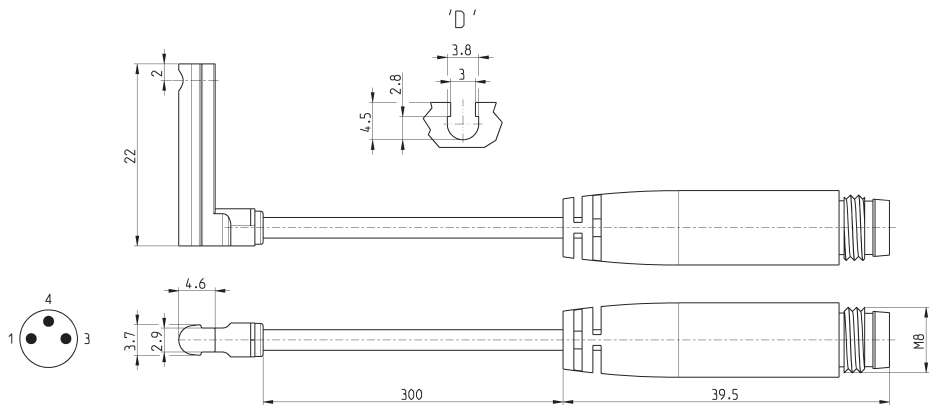

Mod.	Operation	Connection	Voltage	Output	Max current	Max load	Protection
CSD-H-364	Magneto-resistive	3 wires with M8 connector	10 ÷ 27 V DC	PNP	200 mA	6 W	Against polarity reversing and overvoltage
CSD-H-384	Magneto-resistive	3 wires with M8 connector	10 ÷ 27 V DC	NPN	200 mA	6 W	Against polarity reversing and overvoltage