

Series MX coalescing filters

MX2 ports: G3/8, G1/2, G3/4 - MX3 ports: G3/4, G1
Modular

Bowl with technopolymer cover and bayonet-type mounting



- » High performance and compressed air quality (according to ISO 8573-1)
- » Quality of delivered air according to ISO 8573-1:2010, Classes 1.8.1 and 2.8.2
- » Manual, automatic or depressing drain
- » Polymer bowl locking system
- » Visual blockage indicator
- » Metal bowl also available

The Series MX air treatment components are characterized by a modern, linear and compact design, offering high performances. The perfect integration between metal alloys and technopolymers has allowed the realization of a reliable product, light and strong at the same time. Thanks to a new concept of modularity, moreover, the mounting of components has become easier.

The Series MX has been realized to offer a multi-sector solution that guarantees saving in terms of installation time, space and costs.

A special configurator, available on Camozzi website at <http://catalogue.camozzi.com> (sec. Configurators), allows the customer to choose the most suitable solution for his application, selecting single components or by configuring assembled FRLs.

GENERAL DATA

Construction	modular, compact
Materials	see TABLE OF MATERIALS on the following page
Ports	MX2: G3/8, G1/2, G3/4 - MX3: G3/4, G1
Condensate capacity	MX2: 55 cm ³ - MX3: 85 cm ³
Mounting	vertical in-line or wall-mounting (by means of clamps)
Operating temperature	-5°C ÷ 50°C up to 16 bar (with the dew point of the fluid lower than 2°C at the min. working temp.) -5°C ÷ 60°C up to 10 bar (with the dew point of the fluid lower than 2°C at the min. working temp.)
Draining of condensate	manual-semi automatic (standard), automatic, depressurization protected, direct G1/8 exhaust
Operating pressure	0.3 ÷ 16 bar (with automatic drain 1.5 ÷ 12 bar)
Nominal flow	see FLOW DIAGRAMS on the following pages
Quality of delivered air according to ISO 8573-1:2010	Class 2.8.2 with 1 µm filtering element; Class 1.8.1 with 0.01 µm filtering element
Residual oil content with inlet at 3 mg/m ³	< 0.01mg/m ³ < 0.1mg/m ³
Oil retain efficiency	99.80% 97%
Particles retain efficiency	99.99999% 99.999%
Fluid	compressed air
Pre-filtering with filtering element of 1µm	it is recommended to use a filter of 5µm
Pre-filtering with filtering element of 0.01µm	it is recommended to use a filter of 1µm

CODING EXAMPLE

MX	2	-	1/2	-	FC	0	0	M	1	-	LH
-----------	----------	----------	------------	----------	-----------	----------	----------	----------	----------	----------	-----------

MX	SERIES
2	SIZE: 2 = G3/8 - G1/2 - G3/4 3 = G3/4 - G1
1/2	PORTS: 3/8 = G3/8 1/2 = G1/2 3/4 = G3/4 1 = G1
FC	COALESCING FILTER
0	FILTERING ELEMENT: 0 = 0,01 µm (standard) 1 = 1 µm
0	DRAINING OF CONDENSATE (further details in the dedicated section): 0 = semiautomatic-manual drain (standard - only for polymer bowl) 3 = automatic drain 5 = depressuring drain, protected (only for polymer bowl) 8 = without drain, with port G1/8
M	TYPE OF BOWL: = polymer (standard) M = metal (only for MX2-1/2 and MX3-1)
1	VISUAL BLOCKAGE INDICATOR: = not present 1 = present
LH	FLOW DIRECTION: = from left to right (standard) LH = from right to left

SERIES MX COALESCING FILTERS

For the assembly of a single component with fixing flanges or wall-mounting, see the section "FRL Series MX Assembled"

Coalescing filters Series MX - materials

A = Filter
B = Filter with visual blockage indicator

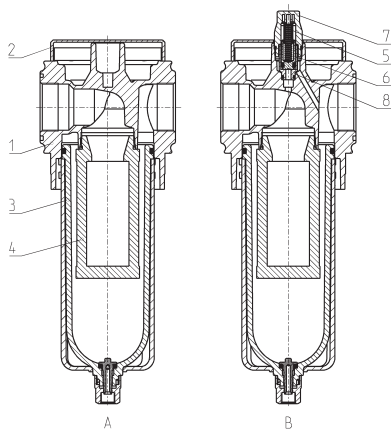

PARTS	MATERIALS
1 = Body	Aluminium
2 = Covering	Polyacetal
3 = Bowl / bowl cover	Polycarbonate/Polyamide/Aluminium
4 = Filtering element	Borosilicate
5 = Upper spring	Stainless steel
6 = Piston	Anodized aluminium
7 = Visual blockage indicator	Polycarbonate
8 = Indicator body	Brass
Seals	NBR

MX2 COALESCING FILTERS FLOW DIAGRAMS

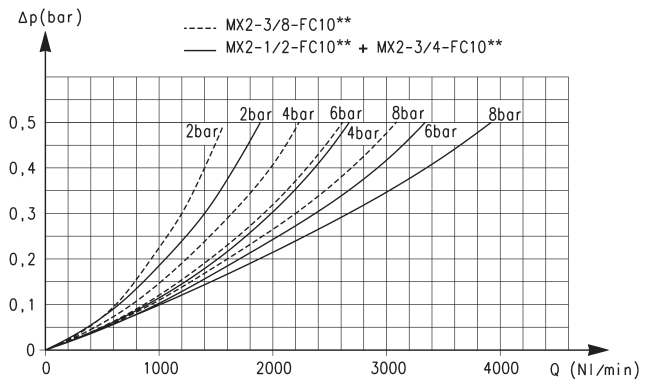
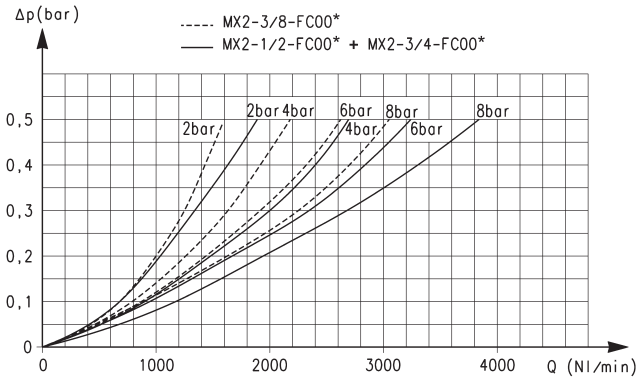

* Reference diagram for models with filtering element = 0.01 µm

** Reference diagram for models with filtering element = 1 µm

Δp = Pressure drop (bar)
Q = Flow (NL/min)

Δp = Pressure drop (bar)
Q = Flow (NL/min)

MX3 COALESCING FILTERS FLOW DIAGRAMS

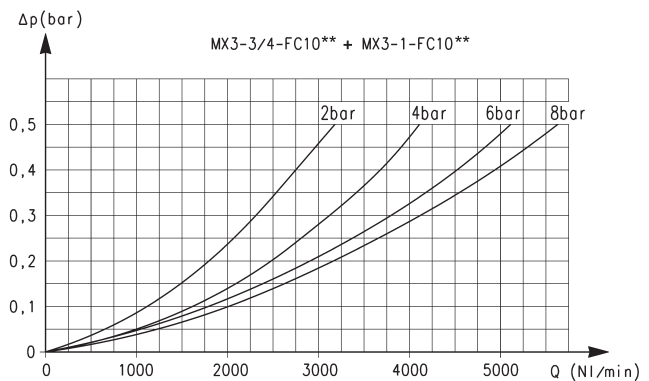
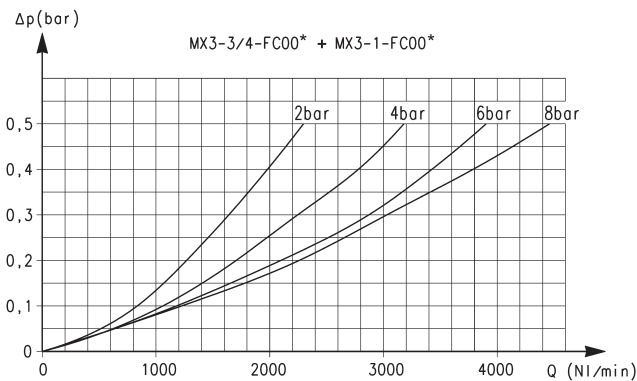

* Reference diagram for models with filtering element = 0.01 µm

** Reference diagram for models with filtering element = 1 µm

Δp = Pressure drop (bar)
Q = Flow (NL/min)

Δp = Pressure drop (bar)
Q = Flow (NL/min)

Coalescing filters Series MX - dimensions

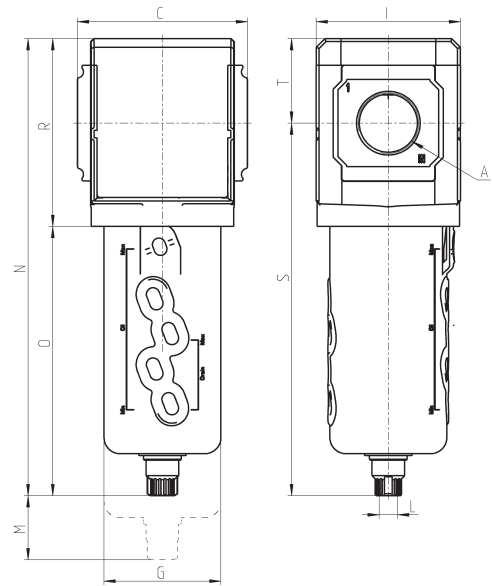

Mod.	A	C	G	I	L	M	N	O	R	S	T	Weight (Kg)
MX2-3/8-FC00	G3/8	70	55.3	68	G1/8	52	212	127	85	174.5	37.5	0.5
MX2-1/2-FC00	G1/2	70	55.3	68	G1/8	52	212	127	85	174.5	37.5	0.5
MX2-3/4-FC00	G3/4	70	55.3	68	G1/8	52	212	127	85	174.5	37.5	0.5
MX3-3/4-FC00	G3/4	89.5	61.5	76	G1/8	75	241	142	99	196.5	44.5	0.8
MX3-1-FC00	G1	89.5	61.5	76	G1/8	75	241	142	99	196.5	44.5	0.8
MX2-1/2-FC03M	G1/2	70	60	68	G1/8	52	205	120	85	167.5	37.5	0.6
MX3-1-FC03M	G1	89.5	67	76	G1/8	75	233	134	99	188.5	44.5	0.8

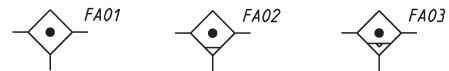

FA01 = coalescing filter without drain with port G1/8

FA03 = coalescing filter with automatic or depressuring drain

FA02 = coalescing filter with semi-automatic manual drain

Coalescing filters with visual blockage indicator Series MX - dimensions

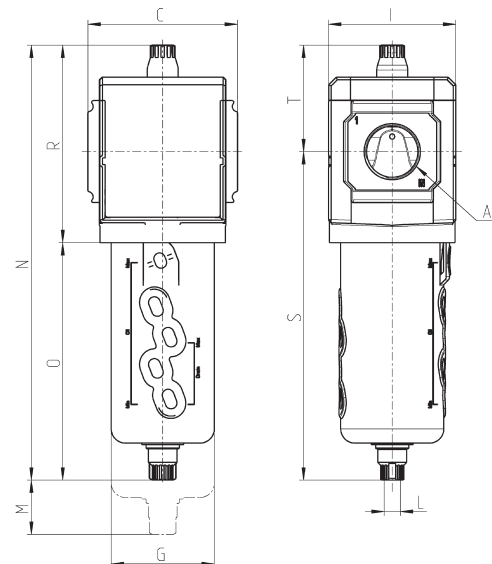

Mod.	A	C	G	I	L	M	N	O	R	S	T	Weight (Kg)
MX2-3/8-FC001	G3/8	70	55.3	68	G1/8	52	231	127	104	174.5	56.5	0.5
MX2-1/2-FC001	G1/2	70	55.3	68	G1/8	52	231	127	104	174.5	56.5	0.5
MX2-3/4-FC001	G3/4	70	55.3	68	G1/8	52	231	127	104	174.5	56.5	0.5
MX3-3/4-FC001	G3/4	89.5	61.5	76	G1/8	75	260	142	118	196.5	63.5	0.8
MX3-1-FC001	G1	89.5	61.5	76	G1/8	75	260	142	118	196.5	63.5	0.8
MX2-1/2-FC03M1	G1/2	70	60	68	G1/8	52	224	120	104	167.5	56.5	0.6
MX3-1-FC03M1	G1	89.5	67	76	G1/8	75	252	134	118	188.5	63.5	0.8

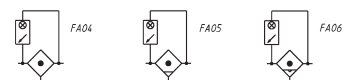

FA04 = coalescing filter without drain, with port G1/8 and visual blockage indicator
FA05 = coalescing filter with semi-automatic manual drain and visual

blockage indicator
FA06 = coalescing filter with automatic or depressuring drain and visual blockage indicator