

Series MX take-off blocks

MX2 port: G1/2 - MX3 port: G1
Modular



- » Compact design
- » Available with or without VNR (no return valve)
- » Pressure switches available on request

The Take-off blocks, when equipped with a no return valve, can be used to bleed non lubricated air.

The Series MX has been realized to offer a multi-sector solution that guarantees saving in terms of installation time, space and costs.

A special configurator, available on Camozzi website at <http://catalogue.camozzi.com> (sec. Configurators), allows the customer to choose the most suitable solution for his application, selecting single components or by configuring assembled FRLs.

GENERAL DATA

Construction	modular, compact, diaphragm-type
Materials	see TABLE OF MATERIALS on the following page
Ports	MX2: G1/2 MX3: G1
Take-off ports	MX2: G1/2 MX3: G1
Mounting	in-line wall-mounting (by means of clamps)
Operating temperature	-5°C ÷ 50°C up to 16 bar (with the dew point of the fluid lower than 2°C at the min. working temperature) -5°C ÷ 60°C up to 10 bar (with the dew point of the fluid lower than 2°C at the min. working temperature)
Nominal flow at 6 bar with $\Delta p = 1$ bar	MX2-1/2-B00 = 6800 NI/min MX2-1/2-B01 = 5700 NI/min MX3-1-B00 = 14500 NI/min MX3-1-B01 = 10500 NI/min
Fluid	compressed air

CODING EXAMPLE

MX	2	-	1/2	-	B	00	-	LH
-----------	----------	----------	------------	----------	----------	-----------	----------	-----------

MX	SERIES
2	SIZE: 2 = G1/2 3 = G1
1/2	PORT: 2 = G1/2 3 = G1
B	TAKE-OFF BLOCK
00	DESIGN TYPE: 00 = without no return valve (standard) 01 = with no return valve 02 = without no return valve, with double O-ring seat
LH	FLOW DIRECTION: = from left to right (standard) LH = from right to left

SERIES MX TAKE-OFF BLOCKS

For the assembly of a single component with fixing flanges or wall-mounting, see the section "FRL Series MX Assembled"

Take-off blocks Series MX - materials

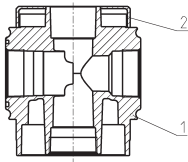

PARTS	MATERIALS
1 = Body	Aluminium
2 = Covering	Polyacetal
Seals	NBR

Series MX take-off blocks - dimensions



TABLE NOTE:
* to complete the code see
the CODING EXAMPLE

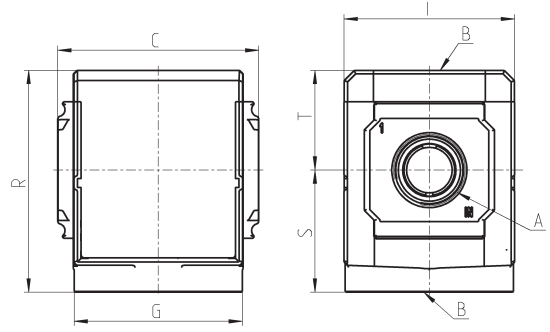

BL01 = take-off block



BL02 = take-off block with VNR

Mod.	A	B	C	G	I	R	S	T	Weight (Kg)
MX2-1/2-B*	G1/2	G1/2	70	65	68	86	47,5	38,5	0.4
MX3-1-B*	G1	G1	89,5	75	76	99	54,5	44,5	0.6

Use of the take-off block MX...- B02

The take-off block with double O-ring seat is particularly suitable when Series MX modules have to be supplied through the same pressure source. The modules which are connected to the left side are of LH kind.

