

Series N filter-regulators

New version

Ports G1/8, G1/4



» Available with: transparent PA12 bowl or nickel-plated brass bowl for the small version (N1)

The version with metal bowl is particularly suitable for applications subject to impacts or in the presence of aggressive agents that could damage the PA12 bowl.

Series N filter-regulator is available with G1/4 and G1/8 ports. Its design incorporates a self relieving diaphragm. The transparent filter bowl allows an easy monitoring of the condensate level. The semi-automatic manual drain makes both the manual and automatic condensate exhaust easier when there is no pressure.

GENERAL DATA

Construction	HDPE and coalescing filtering element
Materials	brass body and poppet stainless steel spring NBR O-ring HDPE filtering element transparent PA12 or nickel-plated bowl others: PA
Ports	G1/8 - G1/4
Max. condensate capacity	11 cm ³ (bowl size = 1) 28 cm ³ (bowl size = 2)
Weight	0.370 Kg
Pressure gauge ports	G1/8
Mounting	vertical, in-line
Operating temperature	-5°C ÷ 50°C a 10 bar (with the dew point of the fluid lower than 2°C at the min. working temperature)
Quality of delivered air according to ISO 8573-1 2010	Class 7.8.4 with 25 µm filtering element Class 6.8.4 with 5 µm filtering element
Draining of condensate	see the coding example
Inlet pressure	with standard drain and protected depressurisation 0.3 ÷ 16 bar
Outlet pressure	with depressurisation drain 0.3 ÷ 10 bar
Nominal flow	see FLOW DIAGRAMS on the following pages
Secondary pressure relieving	with relieving (standard) without relieving
Fluid	compressed air

CODING EXAMPLE

N	2	04	-	D	0	0	-	4	-
----------	----------	-----------	----------	----------	----------	----------	----------	----------	----------

N	SERIES
2	SIZE: 1 = small bowl (11 cm ³) 2 = normal bowl (28 cm ³)
04	PORTS: 08 = G1/8 04 = G1/4
D	D = FILTER-REGULATOR
0	FILTERING ELEMENT: 0 = 25µm (standard) 1 = 5µm
0	DRAINING OF CONDENSATE (further details in the dedicated section) AND DESIGN TYPE: 0 = semi-automatic manual drain with self-relieving 1 = semi-automatic manual drain without relieving 4 = depressurisation with self-relieving (with normal bowl only) 5 = protected depressurisation with self-relieving (with normal bowl only) 8 = no drain (direct port 1/8), with self-relieving
4	OPERATING PRESSURE: = 0.5 ÷ 10 bar (standard) 2 = 0 ÷ 2 bar 4 = 0 ÷ 4 bar 7 = 0.5 ÷ 7 bar
	BOWL MATERIAL: = transparent PA12 (standard) TM = nickel-plated brass (only in the small size with semi-automatic manual drain or without drain)

SERIES N FILTER-REGULATORS

Series N filter-regulators



FR01 = filter-regulator with relieving and manual drain
FR02 = FR with relieving and without drain
FR11 = FR with manual drain and without relieving

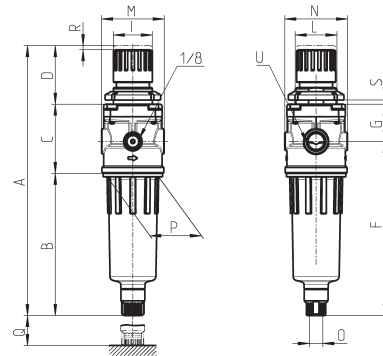
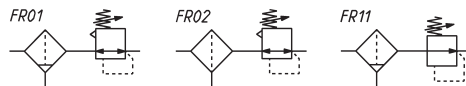

Mod.	A	B	C	D	F	G	I	L	M	N	O	P	Q	R	S	U
N108-D00	167	78	50	39	101	27	28	M30x1,5	45	45	G1/8	38	40	3	0 ÷ 6	G1/8
N104-D00	167	78	50	39	101	27	28	M30x1,5	45	45	G1/8	38	40	3	0 ÷ 6	G1/4
N208-D00	191	102	50	39	125	27	28	M30x1,5	45	45	G1/8	38	40	3	0 ÷ 6	G1/8
N204-D00	191	102	50	39	125	27	28	M30x1,5	45	45	G1/8	38	40	3	0 ÷ 6	G1/4

FLOW DIAGRAMS

SERIES N FILTER-REGULATORS

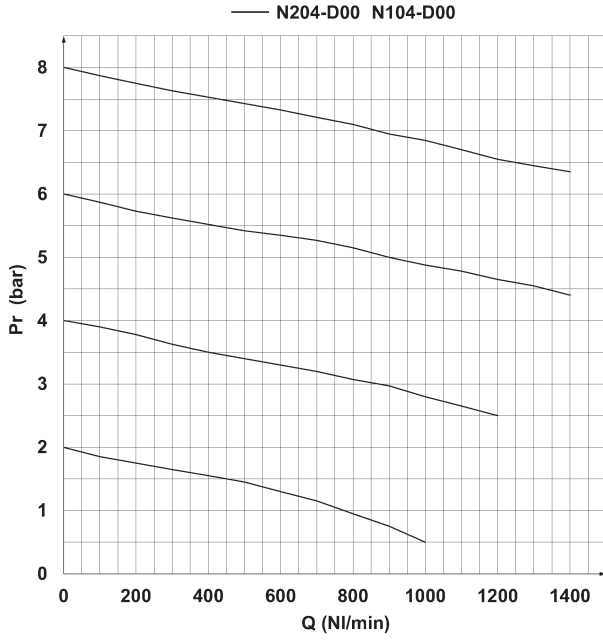

Flow diagrams for models: N204-D00 - N104-D00

Pa = Inlet pressure (bar)
Pr = Regulated pressure (bar)
Qn = Flow (NL/min)

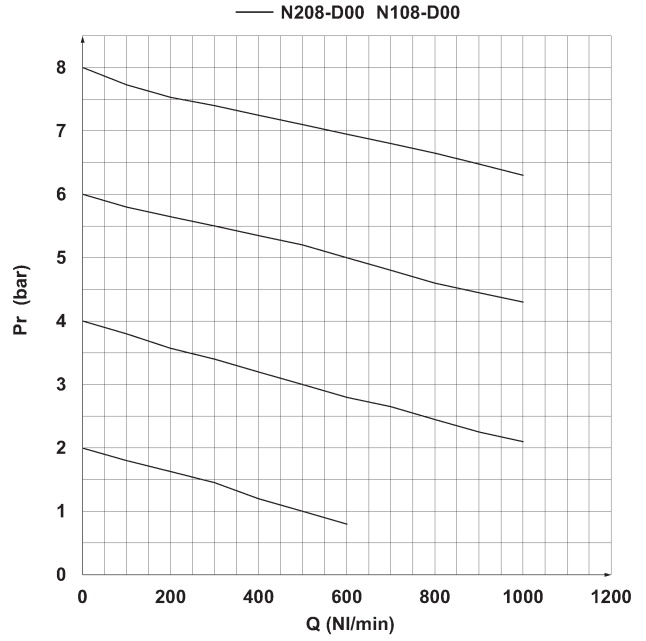

Flow diagrams for models: N208-D00 - N108-D00

Pa = Inlet pressure (bar)
Pr = Regulated pressure (bar)
Qn = Flow (NL/min)