



Series N filters, coalescing filters and activated carbon filters

Ports: G1/8, G1/4



Series N filters are available with G1/8 and G1/4 gas ports. The models are available with 3 different filtering elements: 25, 5, 0.01µm and activated carbon.

- » Available with: transparent PA12 bowl or nickel-plated brass bowl for the small version (N1)
- » Quality of delivered air according to ISO 8573-1:2010 from Class 7.8.4 to Class 1.7.1

The version with semi-automatic manual drain is equipped with a transparent bowl that makes the monitoring of the condensate level very easy.

The version with metal bowl is particularly suitable for applications subject to impacts or in the presence of aggressive agents that could damage the PA12 bowl.

GENERAL DATA

Construction	HDPE, coalescing and activated carbon filtering element
Materials	brass, transparent PA12 or nickel-plated brass, NBR
Ports	G1/8 - G1/4
Max. condensate capacity	11 cm ³ (bowl size = 1) 28 cm ³ (bowl size = 2)
Weight	0.220 kg
Mounting	vertical, inline
Operating temperature	-5°C ÷ 50°C at 10 bar (with the dew point of the fluid lower than 2°C at the min. working temperature)
Quality of delivered air according to ISO 8573-1 2010	Class 7.8.4 with 25 µm filtering element Class 6.8.4 with 5 µm filtering element Class 1.8.1 with 0.01 µm filtering element Classe 1.7.1 with activated carbon filtering element
Draining of condensate	see the coding example
Operating pressure	0.3 ÷ 16 bar (with depressurisation max 10 bar)
Nominal flow	see FLOW DIAGRAMS on the following pages
Fluid	Compressed air
Pre-filtering	it is recommended to use a filter with residual oil of 0.01mg/m ³

CODING EXAMPLE

N	2	04	-	F	0	0	-
----------	----------	-----------	----------	----------	----------	----------	----------

N	SERIES
2	SIZE: 1 = small bowl (11 cm ³) 2 = normal bowl (28 cm ³)
04	PORTS: 08 = G1/8 04 = G1/4
F	F = FILTER
0	FILTERING ELEMENT: 0 = 25µm (standard) 1 = 5µm B = 0.01µm CA = activated carbon (without drain, only closed bowl size 2)
0	DRAINING OF CONDENSATE (further details in the dedicated section): 0 = semi-automatic manual drain 4 = depressurisation (normal bowl only) 5 = protected depressurisation (normal bowl only) 8 = no drain, direct G1/8 exhaust
	BOWL MATERIAL: = transparent PA12 (standard) TM = nickel-plated brass (only in the small size with semi-automatic manual drain or without drain, port 1/8)

SERIES N FILTERS

Filters Series N



FT01 = filter without drain with threaded port
 FT02 = filter with semiautomatic manual drain
 FA01 = coalescing filter without drain with threaded port
 FA02 = coalescing filter with semi-automatic manual drain
 FC01 = absorption function without bowl hole

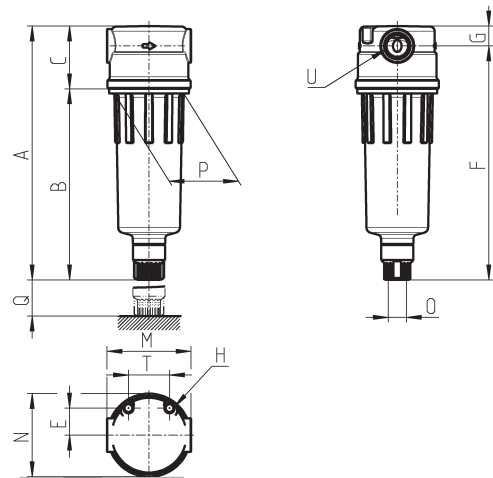

DIMENSIONS															
Mod.	A	B	C	E	F	G	H	M	N	O	P	Q	T	U	
N108-F00	111	78	33	14.5	101	10	M5	45	44.5	G1/8	38	40	22	G1/8	
N104-F00	111	78	33	14.5	101	10	M5	45	44.5	G1/8	38	40	22	G1/4	
N208-F00	135	102	33	14.5	125	10	M5	45	44.5	G1/8	38	40	22	G1/8	
N204-F00	135	102	33	14.5	125	10	M5	45	44.5	G1/8	38	40	22	G1/4	
N208-FCA	117	84	33	14.5	107	10	M5	45	44.5	G1/8	38	69	22	G1/8	
N204-FCA	117	84	33	14.5	107	10	M5	45	44.5	G1/8	38	69	22	G1/4	

FLOW DIAGRAMS

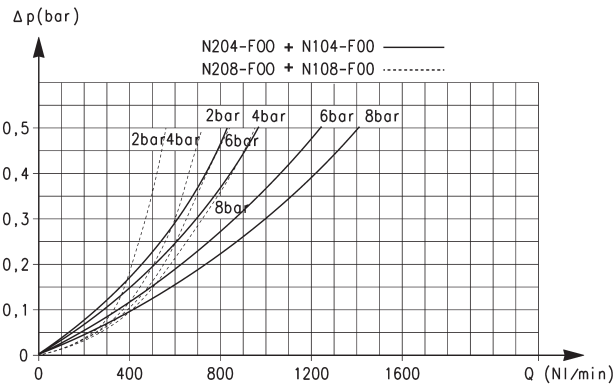

Flow diagram for models:
 N204-F00 - N104-F00 = _____
 N208-F00 - N108-F00 = - - - - -

ΔP = Pressure drop (bar)
 Q = Flow (NL/min)

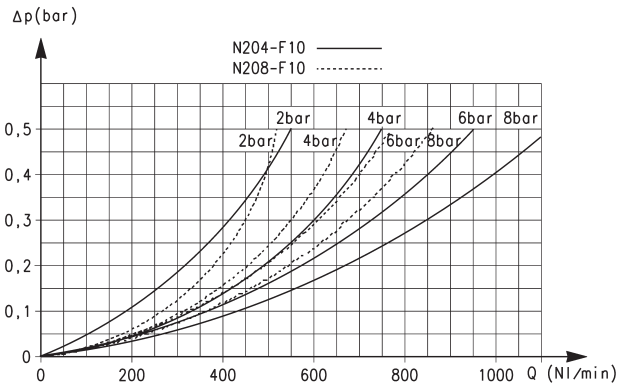

Flow diagram for models:
 N204-F10 = _____
 N208-F10 = - - - - -

ΔP = Pressure drop (bar)
 Q = Flow (NL/min)

FLOW DIAGRAMS

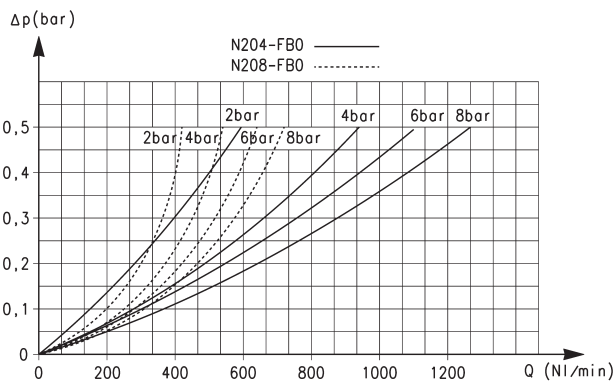

Flow diagram for models:
 N204-FB0 = _____
 N208-FB0 = - - - - -

ΔP = Pressure drop (bar)
 Q = Flow (NL/min)

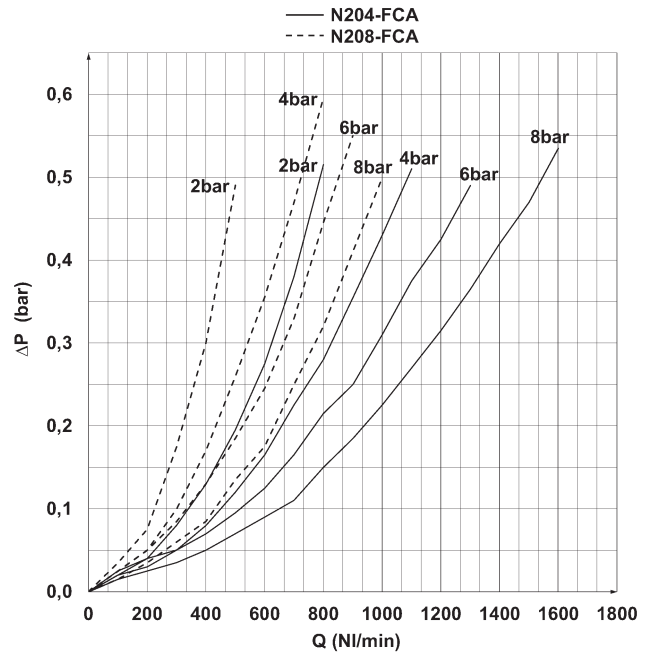

Flow diagram for models:
 N204-FCA = _____
 N208-FCA = - - - - -

ΔP = Pressure drop (bar)
 Q = Flow (NL/min)