

Proportional pressure regulator Series PME

New

Two sizes available: PME1 and PME2
Ports G1/8 - G1/4 - G3/8 - 1/4NPTF

CANopen

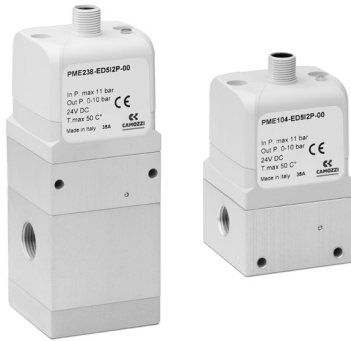

- » Manifold version
- » Integrated exhaust valve version
- » Modular with Series MD
- » Configuration APP that uses NFC technology
- » Compact and essential
- » Compatible with OXYGEN
- » Serial version in CANopen

The Series PME proportional pressure regulator is the ideal solution for industrial applications that require accurate pressure control. This new pressure regulator offers a high pneumatic performance, despite having its weight and dimensions reduced to a minimum to allow greater flexibility in its use.

Series PME is available in two sizes and versions. One version has an integrated exhaust valve that allows the system to discharge even in the absence of power. The second is a manifold version, ideal for controlling several outlets with only a single air inlet. A new CANopen serial version is also available. Ideal for controlling multiple controllers on a single fieldbus and for applications that need to operate within a wide supply voltage range (12÷24 V DC).

GENERAL DATA

Standard of reference	CE	
Controlled quantity	Pressure	
Number of ways	3	
Flow (Qn)	PME104 - 1100 NL/min	PME238 - 4600 NL/min
Media	Filtered and non-lubricated compressed air of class [7:4:4] according to ISO 8573.1. Inert gases and oxygen	
Min & max regulated pressure (bar)	0,05 - 10,3 bar (0,72-150 PSI)(D) 0,05 - 7 bar (0,72-101,5 PSI) (G)	0,05 - 6 bar (0,72-87 PSI)(F)
Maximum inlet pressure	11 bar (D); (G) ed (F)	
Resolution (% FS)	0,3 (Size 1) 0,6 (Size 2)	
Fluid temperature (min and max °C)	0 - 50 °C	
Environmental temperature (min and max °C)	0 - 50 °C	
Pneumatic ports	G1/8 - G1/4 - G3/8 - 1/4 NPTF	
Materials	body: aluminium - cover: technopolymer - seals: NBR or FKM	
Supply voltage (V)	12 ÷ 24 V DC (only for CANopen version)	
Command signal	0-10V (2); 4-20 mA (4); CANopen (C)	
Hysteresis (% FS)	0,5% (Size 1) 0.7% (Size 2)	
Power consumption	From minimum 110 to maximum 200 mA (see further details in the product manual)	
Type of electrical connection	M12 5 Pin Male	
IP protection class	IP65	
Repeatability (% FS)	0,4	
Linearity (% FS)	0,4	
Modularity	with Series MD	
App for mobile device	Download from Google Playstore (NFCamApp)	
CANopen Profile	CiA 301 and CiA 408 (using serial communication a multitude of feedback information is available, like the set pressure value or the communication errors, that are not present on the other versions of the Series PME).	

CODING EXAMPLE

PME	1	04	-	E	D	5	I	2	E	-	00
------------	----------	-----------	----------	----------	----------	----------	----------	----------	----------	----------	-----------

PME	SERIES
1	SIZE: 1 = Size 1 2 = Size 2
04	CONNECTION PORT: 04 = G1/4 38 = G3/8 (only size 2) M4 = G1/4 Manifold 14 = NPTF 1/4 (only size 1) N4 = 1/4 NPTF Manifold 08 = G1/8 (only size 1) M8 = G1/8 Manifold (only size 1)
E	DIAGNOSTICS: E = Without WiFi No Diagnostics
D	WORKING PRESSURE: F = 0-6 bar (standard for OX1 version with internal servo-pilot supply) G = 0-7 bar (OX1 versions only with external servo-pilot supply with air) D = 0-10,3 bar (OX1 versions only with external servo-pilot supply with air)
5	VALVE FUNCTION: 5 = Standard, 3-way NC version. Size 1 and 2 with port 3 and pilot exhaust not conveyable. 6 = Version with integrated exhaust valve (maximum working pressure F or G). Size 1 and 2 with port 3 and pilot exhaust not conveyable. 7 = Standard, 3-way NC version. Size 1 and 2 with port 3 and pilot exhaust conveyable. 8 = Version with integrated exhaust valve (maximum working pressure F or G). Size 1 and 2 with port 3 and pilot exhaust conveyable
I	PILOT SUPPLY: I = Internal E = External
2	COMMAND SIGNAL: 2 = 0-10V 4 = 4-20mA C = CANopen
E	FEEDBACK DIGITAL OUTPUT SIGNAL: N = without digital output (only with CANopen version) E = error (only with input signal 2, 4) P = pressure switch (only with input signal 2, 4) W = pressure switch with "window" function (only with input signal 2, 4)
00	CABLE LENGTH: 00 = No cable 2F = 2mt 5 pin straight unshielded 2R = 2mt 5 pin 90° cable unshielded 5F = 5mt 5 pin straight unshielded 5R = 5mt 5 pin 90° cable unshielded 2R3 = 2 mt 90° cable, 3 wires (*) unshielded 5R3 = 2 mt 90° cable, 3 wires (*) unshielded 2FC = 2mt 5 pin straight shielded 2RC = 2mt 5 pin 90° cable shielded 5FC = 5mt 5 pin straight shielded 5RC = 5mt 5 pin 90° cable shielded
OX1	CERTIFICATES: = no certificate OX1 = for use with oxygen, available in the versions "Working pressure" F; and with "Valve Function" 7; 8.
Version suitable to be used with oxygen. With a working pressure of Max 6 Bar, available both with internal and external pilot supply; with all other versions only with external pilot supply.	

SERIES PME PROPORTIONAL PRESSURE REGULATOR

(*) in the cable versions with 3 wires, only pins 1 (24 VDC), 4 (GND) and 3 (IN +) are available. On the other hand, pin 5 (Dout) is not available.

DIMENSIONAL CHARACTERISTICS SERIES PME SIZE 1

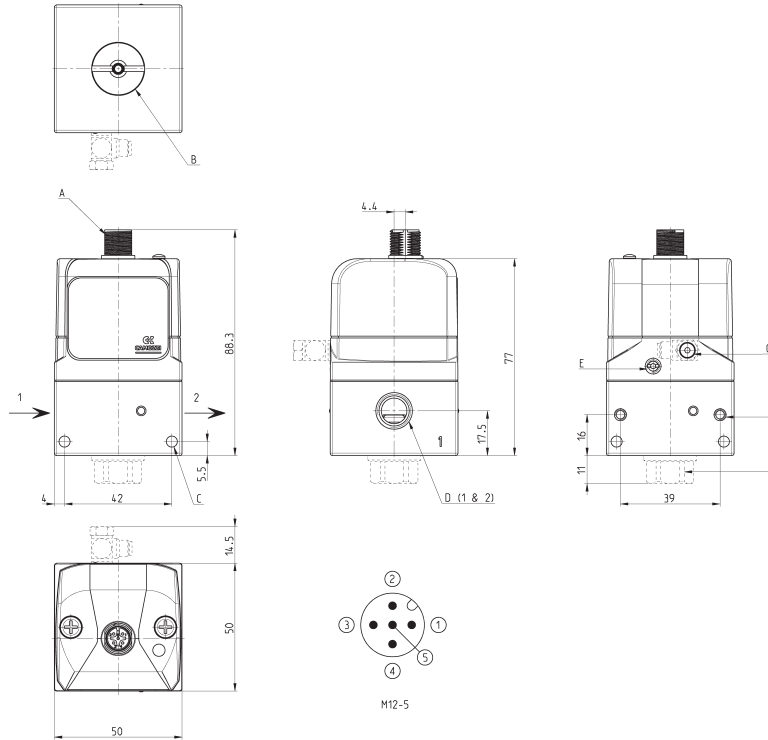

Mod.	A	B (3)	C	D (1 & 2)	E	F	G	H (3)	Symbols
PME104-Ex5Ixx-xx	Electrical connection M12 5 Pin Male	Exhaust regulator NOT conveyed (5)	Fixing holes Ø4,3	Ports G1/8 o G1/4 (GAS o NPTF)	Exhaust solenoid valves	Fixing holes M4	Internal pilot supply	Absent	RE01
PME104-Ex7Ixx-xx	Electrical connection M12 5 Pin Male	Exhaust regulator conveyed (7)	Fixing holes Ø4,3	Ports G1/8 o G1/4 (GAS o NPTF)	Exhaust solenoid valves	Fixing holes M4	Internal pilot supply	Exhaust regulator G1/4 (7)	RE05
PME104-Ex6Ixx-xx	Electrical connection M12 5 Pin Male	Exhaust regulator NOT conveyed (6)	Fixing holes Ø4,3	Ports G1/8 o G1/4 (GAS o NPTF)	Exhaust solenoid valves	Fixing holes M4	Internal pilot supply	Absent	RE03
PME104-Ex8Ixx-xx	Electrical connection M12 5 Pin Male	Exhaust regulator conveyed (8)	Fixing holes Ø4,3	Ports G1/8 o G1/4 (GAS o NPTF)	Exhaust solenoid valves	Fixing holes M4	Internal pilot supply	Exhaust regulator G1/4 (8)	RE07
PME104-Ex5Exx-xx	Electrical connection M12 5 Pin Male	Exhaust regulator NOT conveyed (5)	Fixing holes Ø4,3	Ports G1/8 o G1/4 (GAS o NPTF)	Exhaust solenoid valves	Fixing holes M4	External pilot supply (M5)	Absent	RE02
PME104-Ex7Exx-xx	Electrical connection M12 5 Pin Male	Exhaust regulator conveyed (7)	Fixing holes Ø4,3	Ports G1/8 o G1/4 (GAS o NPTF)	Exhaust solenoid valves	Fixing holes M4	External pilot supply (M5)	Exhaust regulator G1/4 (7)	RE06
PME104-Ex6Exx-xx	Electrical connection M12 5 Pin Male	Exhaust regulator NOT conveyed (6)	Fixing holes Ø4,3	Ports G1/8 o G1/4 (GAS o NPTF)	Exhaust solenoid valves	Fixing holes M4	External pilot supply (M5)	Absent	RE04
PME104-Ex8Exx-xx	Electrical connection M12 5 Pin Male	Exhaust regulator conveyed (8)	Fixing holes Ø4,3	Ports G1/8 o G1/4 (GAS o NPTF)	Exhaust solenoid valves	Fixing holes M4	External pilot supply (M5)	Exhaust regulator G1/4 (8)	RE08

DIMENSIONAL CHARACTERISTICS SERIES PME SIZE 2



SERIES PME PROPORTIONAL PRESSURE REGULATOR

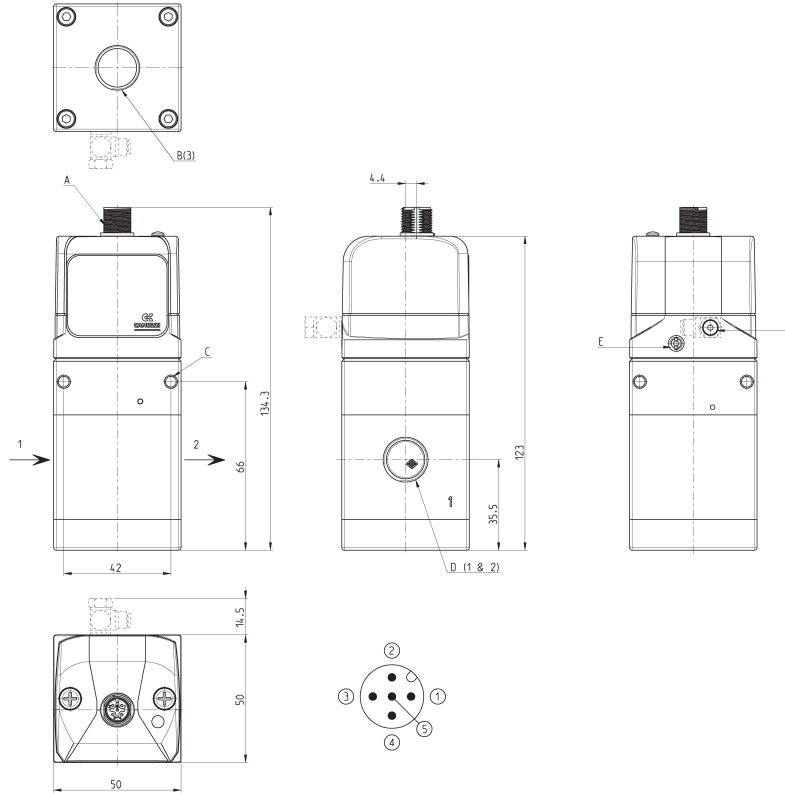

Mod.	A	B (3)	C	D (1 & 2)	E	F	Symbols
PME2xx-Ex5Ixx-xx	Electrical connection M12 5 Pin Male	Exhaust regulator G3/8	Fixing holes Ø4,3	Ports G3/8 or G1/4	Exhaust solenoid valves	Internal pilot supply	RE01
PME2xx-Ex6Ixx-xx	Electrical connection M12 5 Pin Male	Exhaust regulator G3/8	Fixing holes Ø4,3	Ports G3/8 or G1/4	Exhaust solenoid valves	Internal pilot supply	RE03
PME2xx-Ex5Exx-xx	Electrical connection M12 5 Pin Male	Exhaust regulator G3/8	Fixing holes Ø4,3	Ports G3/8 or G1/4	Exhaust solenoid valves	External pilot supply (M5)	RE02
PME2xx-Ex6Exx-xx	Electrical connection M12 5 Pin Male	Exhaust regulator G3/8	Fixing holes Ø4,3	Ports G3/8 or G1/4	Exhaust solenoid valves	External pilot supply (M5)	RE04

DIMENSIONAL CHARACTERISTICS SERIES PME SIZE 1 MANIFOLD



The fixing pins of the Manifold version are always included.

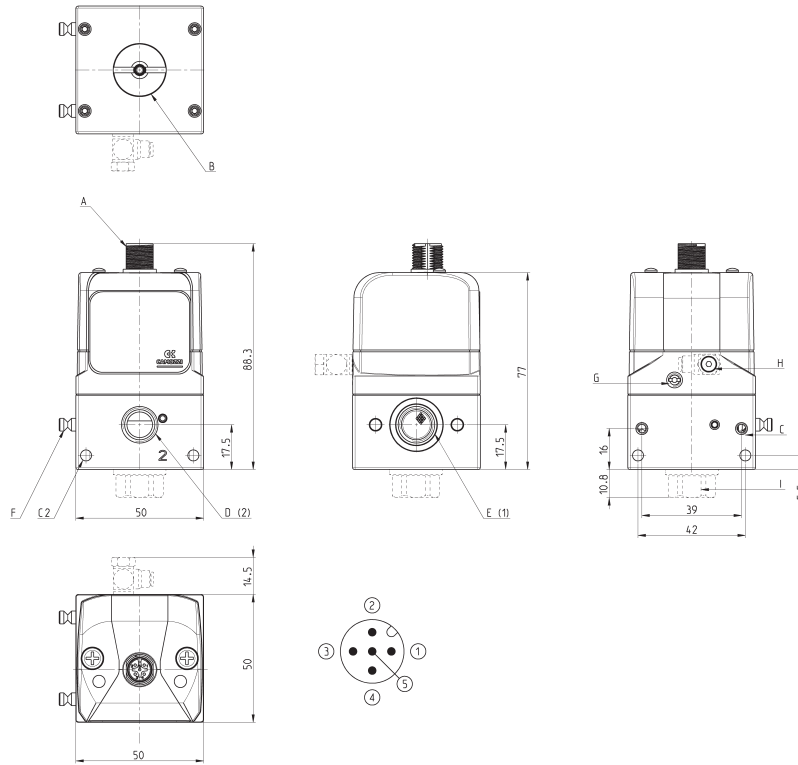

Mod.	A	B (3)	C	D (2)	E (1)	F	G	H	I (3)	Symbols
PME1M4-Ex5lxx-xx	Electrical connection M12 5 Pin Male	Exhaust regulator NOT conveyed (5)	Fixing holes $\varnothing 4,3$	Port G 1/4	Ports G1/8 or G1/4	Connection plug	Exhaust solenoid valves	Internal pilot supply	Absent (5)	RE09
PME1M4-Ex6lxx-xx	Electrical connection M12 5 Pin Male	Exhaust regulator NOT conveyed (6)	Fixing holes $\varnothing 4,3$	Port G 1/4	Ports G1/8 or G1/4	Connection plug	Exhaust solenoid valves	Internal pilot supply	Absent (6)	RE11
PME1M4-Ex7lxx-xx	Electrical connection M12 5 Pin Male	Exhaust regulator conveyed (7)	Fixing holes $\varnothing 4,3$	Port G 1/4	Ports G1/8 or G1/4	Connection plug	Exhaust solenoid valves	Internal pilot supply	Exhaust (7) G1/4	RE13
PME1M4-Ex8lxx-xx	Electrical connection M12 5 Pin Male	Exhaust regulator conveyed (8)	Fixing holes $\varnothing 4,3$	Port G 1/4	Ports G1/8 or G1/4	Connection plug	Exhaust solenoid valves	Internal pilot supply	Exhaust (8) G1/4	RE15
PME1M4-Ex5Exx-xx	Electrical connection M12 5 Pin Male	Exhaust regulator NOT conveyed (5)	Fixing holes $\varnothing 4,3$	Port G 1/4	Ports G1/8 or G1/4	Connection plug	Exhaust solenoid valves	External pilot supply (M5)	Absent (5)	RE10
PME1M4-Ex6Exx-xx	Electrical connection M12 5 Pin Male	Exhaust regulator NOT conveyed (6)	Fixing holes $\varnothing 4,3$	Port G 1/4	Ports G1/8 or G1/4	Connection plug	Exhaust solenoid valves	External pilot supply (M5)	Absent (6)	RE12
PME1M4-Ex7Exx-xx	Electrical connection M12 5 Pin Male	Exhaust regulator conveyed (7)	Fixing holes $\varnothing 4,3$	Port G 1/4	Ports G1/8 or G1/4	Connection plug	Exhaust solenoid valves	External pilot supply (M5)	Exhaust (7) G1/4	RE14
PME1M4-Ex8Exx-xx	Electrical connection M12 5 Pin Male	Exhaust regulator conveyed (8)	Fixing holes $\varnothing 4,3$	Port G 1/4	Ports G1/8 or G1/4	Connection plug	Exhaust solenoid valves	External pilot supply (M5)	Exhaust (8) G1/4	RE16

DIMENSIONAL CHARACTERISTICS SERIES PME SIZE 2 MANIFOLD



The fixing pins of the Manifold version are always included.

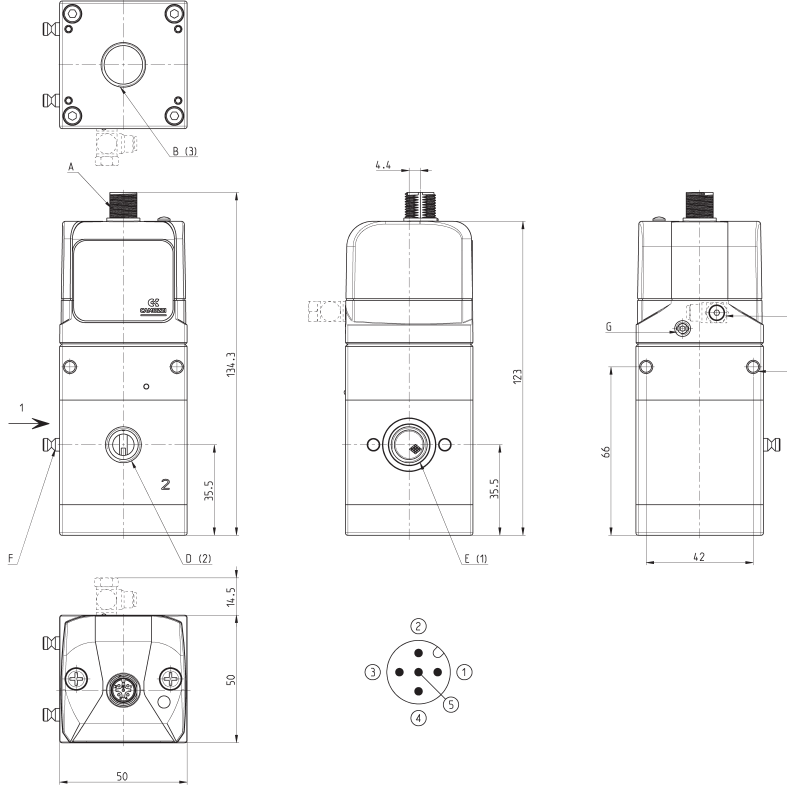

Mod.	A	B (3)	C	D (2)	E (1)	F	G	H	Symbols
PME2M4-Ex5lxx-xx	Electrical connection M12 5 Pin Male	Exhaust regulator G3/8	Fixing holes Ø4,3	Port G1/4 (Gas or NPTF)	Port G1/4 (Gas or NPTF)	Connection plug	Exhaust solenoid valves	Internal pilot supply	RE09
PME2M4-Ex6lxx-xx	Electrical connection M12 5 Pin Male	Exhaust regulator G3/8	Fixing holes Ø4,3	Port G1/4 (Gas or NPTF)	Port G1/4 (Gas or NPTF)	Connection plug	Exhaust solenoid valves	Internal pilot supply	RE11
PME2M4-Ex5Exx-xx	Electrical connection M12 5 Pin Male	Exhaust regulator G3/8	Fixing holes Ø4,3	Port G1/4 (Gas or NPTF)	Port G1/4 (Gas or NPTF)	Connection plug	Exhaust solenoid valves	External pilot supply (M5)	RE10
PME2M4-Ex6Exx-xx	Electrical connection M12 5 Pin Male	Exhaust regulator G3/8	Fixing holes Ø4,3	Port G1/4 (Gas or NPTF)	Port G1/4 (Gas or NPTF)	Connection plug	Exhaust solenoid valves	External pilot supply (M5)	RE12

FLOW CHARTS SIZE 1 - Standard version (G1/4)

Typical curve for version PME104-EF...

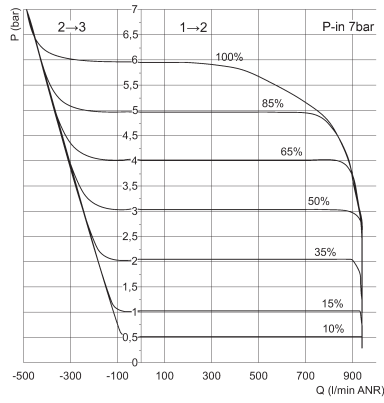

P = Regulated outlet pressure and exhaust pressure
 Q = Flow
 % = Percentage of the command signal

Typical curve for version PME104-EG...

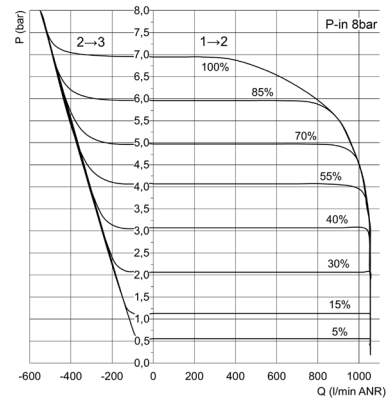

P = Regulated outlet pressure and exhaust pressure
 Q = Flow
 % = Percentage of the command signal

Typical curve for version PME104-ED...

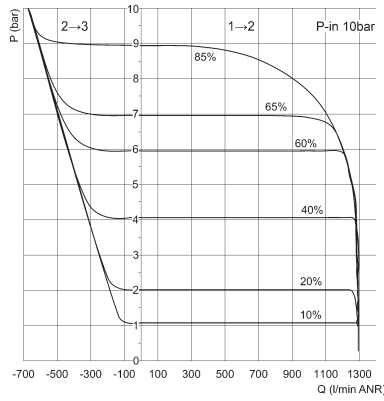

P = Regulated outlet pressure and exhaust pressure
 Q = Flow
 % = Percentage of the command signal

FLOW CHARTS SIZE 1 - Manifold version (G1/4)

Typical curve for version PME1M4-EF...

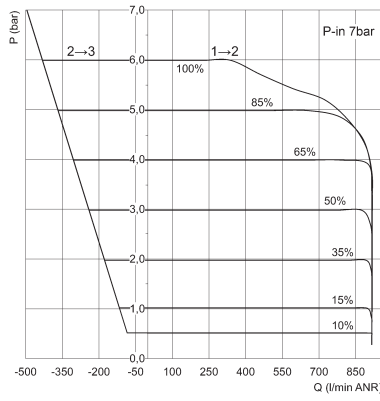

P = Regulated outlet pressure and exhaust pressure
Q = Flow
% = Percentage of the command signal

Typical curve for version PME1M4-EG...

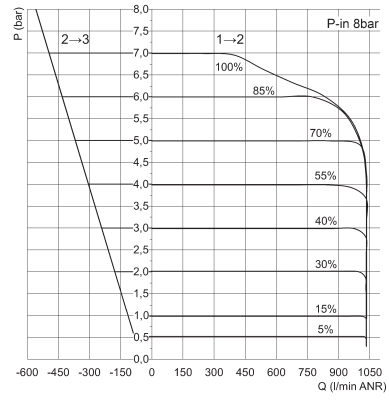

P = Regulated outlet pressure and exhaust pressure
Q = Flow
% = Percentage of the command signal

Typical curve for version PME1M4-ED...

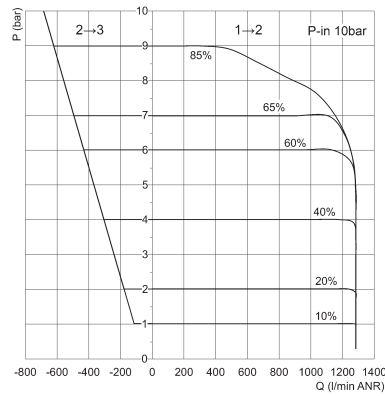

P = Regulated outlet pressure and exhaust pressure
Q = Flow
% = Percentage of the command signal

DECAY FACTOR FOR MANIFOLD REGULATORS SIZE 1

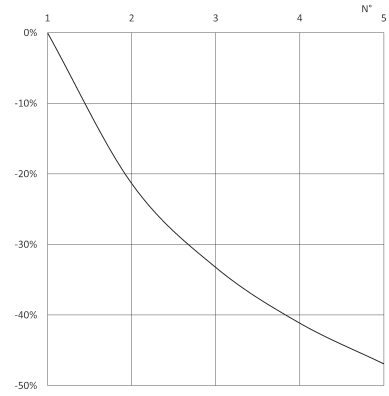

N° = number of regulators in manifold configuration
% = % of decrease in flow rate compared to the maximum flow rate
Note: the air inlet is only from one side, in case it should be on the right and on the left, only consider the positions as from 1 ÷ 3.

FLOW CHARTS SIZE 2 - Version (G1/4)

Typical curve for version PME204-EF...

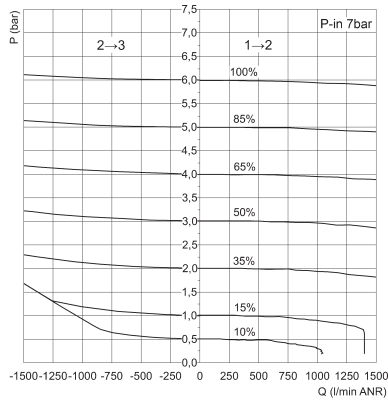

P = Regulated outlet pressure and exhaust pressure
 Q = Flow
 % = Percentage of the command signal

Typical curve for version PME204-EG...

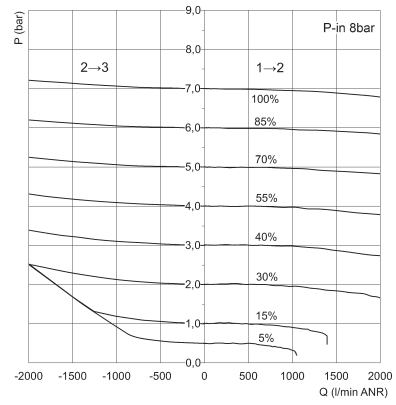

P = Regulated outlet pressure and exhaust pressure
 Q = Flow
 % = Percentage of the command signal

Typical curve for version PME204-ED...

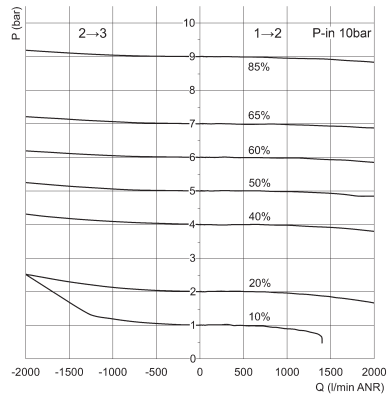

P = Regulated outlet pressure and exhaust pressure
 Q = Flow
 % = Percentage of the command signal

FLOW CHARTS SIZE 2 - Standard Version (G3/8)

Typical curve for version PME238-EF...

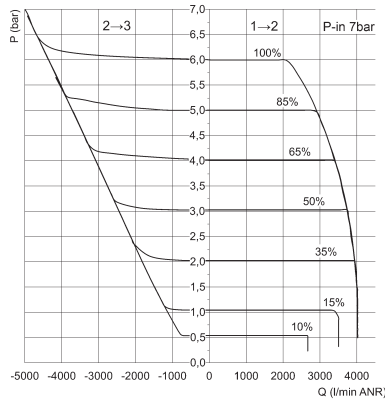

P = Regulated outlet pressure and exhaust pressure
Q = Flow
% = Percentage of the command signal

Typical curve for version PME238-EG...

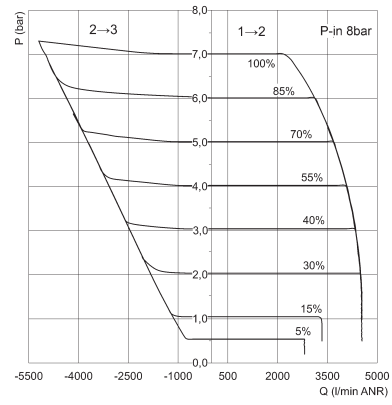

P = Regulated outlet pressure and exhaust pressure
Q = Flow
% = Percentage of the command signal

Typical curve for version PME238-ED...

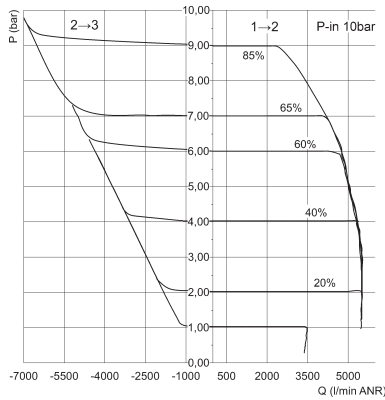

P = Regulated outlet pressure and exhaust pressure
Q = Flow
% = Percentage of the command signal

FLOW CHARTS SIZE 2 - Manifold Version (G1/4)

Typical curve for version PME2M4-EF...

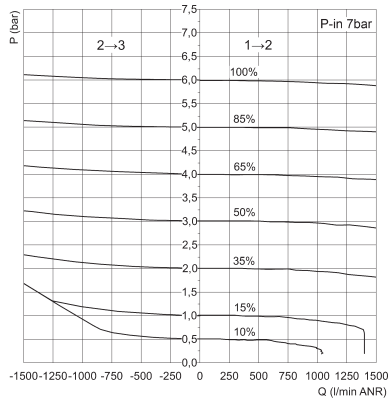

P = Regulated outlet pressure and exhaust pressure
 Q = Flow
 % = Percentage of the command signal

Typical curve for version PME2M4-EG...

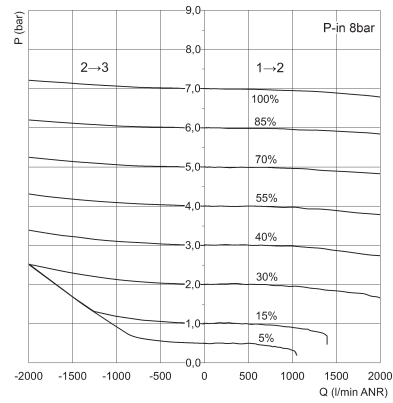

P = Regulated outlet pressure and exhaust pressure
 Q = Flow
 % = Percentage of the command signal

Typical curve for version PME2M4-ED...

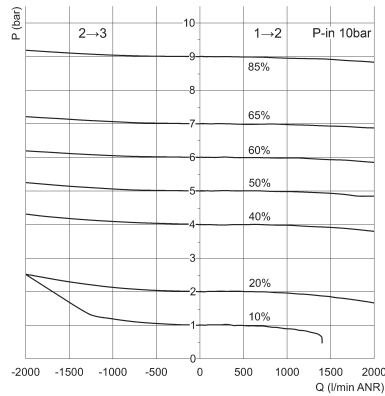

P = Regulated outlet pressure and exhaust pressure
 Q = Flow
 % = Percentage of the command signal

DECAY FACTOR FOR MANIFOLD REGULATORS SIZE 2

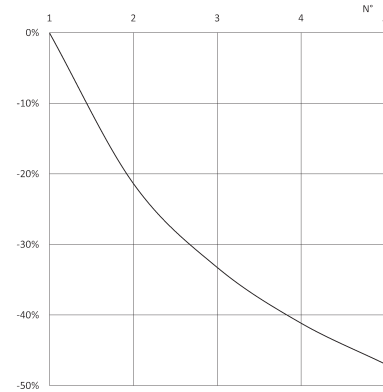

N° = number of regulators in manifold configuration
 % = % of decrease in flow rate compared to the maximum flow rate
 Note: the air inlet is only from one side, in case it should be on the right and on the left, only consider the positions as from 1 ÷ 3.

PNEUMATIC SYMBOLS OF SERIES PME PROPORTIONAL PRESSURE REGULATOR, size 1 and 2

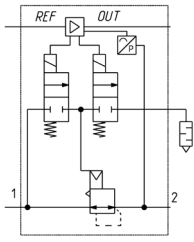

RE01

Version with internal servo-pilot supply and two pilot valves 2/2 NC.

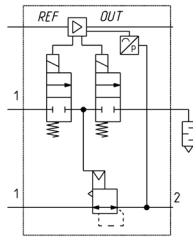

RE02

Version with external servo-pilot supply and two pilot valves 2/2 NC.

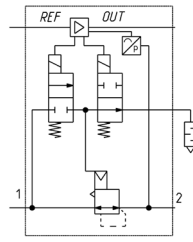

RE03

Version with internal servo-pilot supply and two pilot valves; one 2/2 NC and one 2/2 NO (exhaust)

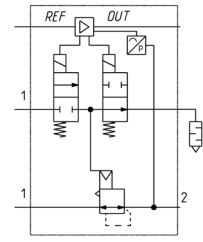

RE04

Version with external servo-pilot supply and two pilot valves; one 2/2 NC and one 2/2 NO (exhaust)

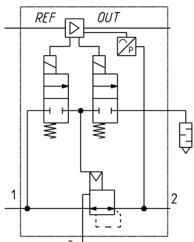

RE05

Version with internal servo-pilot supply and two pilot valves 2/2 NC, exhaust conveyable.

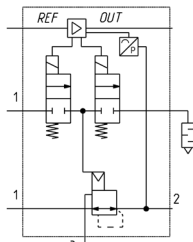

RE06

Version with external servo-pilot supply and two pilot valves 2/2 NC, exhaust conveyable.

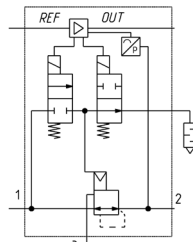

RE07

Version with internal servo-pilot supply and two pilot valves; one 2/2 NC and one 2/2 NO to exhaust, exhaust conveyable.

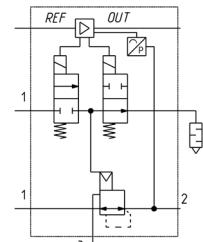

RE08

Version with external servo-pilot supply and two pilot valves; one 2/2 NC and one 2/2 NO to exhaust, exhaust conveyable.

PNEUMATIC SYMBOLS OF SERIES PME PROPORTIONAL PRESSURE REGULATOR, manifold version size 1 and 2

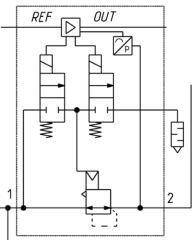

RE09

Manifold version with internal servo-pilot supply and two pilot valves 2/2 NC.

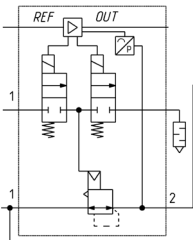

RE10

Manifold version with external servo-pilot supply and two pilot valves 2/2 NC.

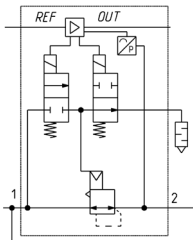

RE11

Manifold version with internal servo-pilot supply and two pilot valves; one 2/2 NC and one 2/2 NO to exhaust.

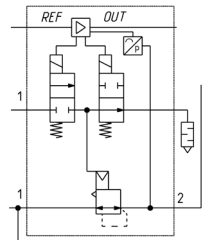

RE12

Manifold version with external servo-pilot supply and two pilot valves; one 2/2 NC and one 2/2 NO to exhaust.

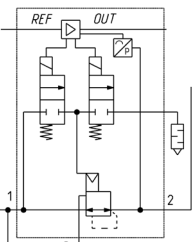

RE13

Manifold version with internal servo-pilot supply and two pilot valves 2/2 NC and exhaust conveyable.

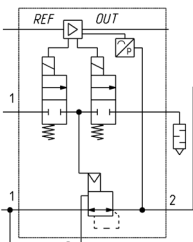

RE14

Manifold version with external servo-pilot supply and two pilot valves 2/2 NC and exhaust conveyable.

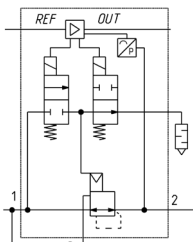

RE15

Manifold version with internal servo-pilot supply and two pilot valves; one 2/2 NC and one 2/2 NO to exhaust, exhaust conveyable.

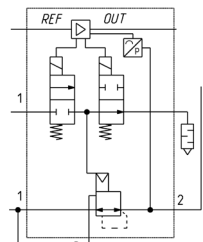

RE16

Manifold version with external servo-pilot supply and two pilot valves; one 2/2 NC and one 2/2 NO to exhaust, exhaust conveyable.

SERIES PME PROPORTIONAL PRESSURE REGULATOR

SIZE 1 - MATERIALS

R = Proportional regulator
M = Proportional regulator - manifold version

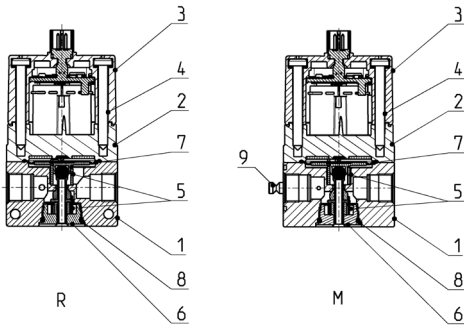

PARTS	MATERIALS, standard version
1 = body	Anodised aluminium
2 = cover	PA6 CM 30%
3 = cap	PARA GF50%
4 = screws	stainless steel
5 = springs	stainless steel
6 = plug	nickel-plated brass
7 = diaphragm	NBR
8 = seals and O-Ring	NBR
9 = pin for manifold version	stainless steel only for manifold version

SIZE 2 - MATERIALS

R = Proportional regulator
M = Proportional regulator - manifold version

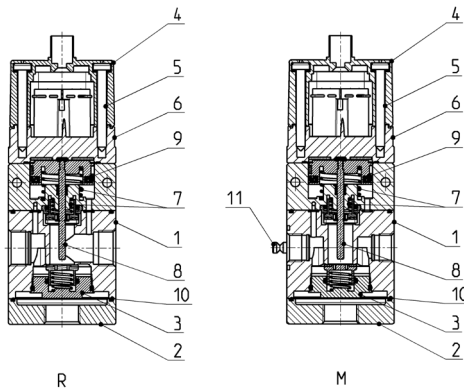

PARTS	MATERIALS, standard version
1 = body	Anodised aluminium
2 = end cover	Anodised aluminium
3 = plug	brass
4 = cover	PA6 CM 30%
5 = screws	stainless steel
6 = valve body	PARA GF50%
7 = springs	stainless steel
8 = piston rod	stainless steel
9 = piston seal	NBR
10 = seals and O-Ring	NBR
11 = pin for manifold version	Stainless steel only for manifold version

PNEUMATIC DIAGRAM FOR INSTALLATION

PME version with integrated exhaust valve.

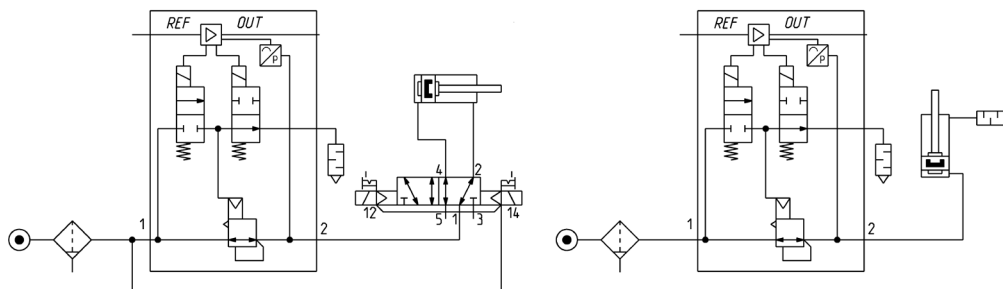

Cable with M12 5 pin connector, straight, female

For power supply and command signal

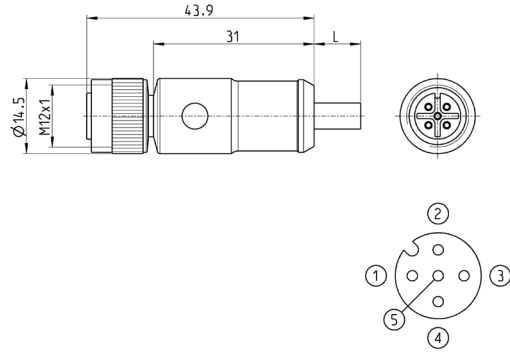

Mod.	Cable length (m)	Shielding	No. wires
CS-LF05HB-C200	2	Unshielded	5
CS-LF05HB-C500	5	Unshielded	5
CS-LF05HB-D200	2	Shielded	5
CS-LF05HB-D500	5	Shielded	5

Cable with M12 5 pin connector, 90°, female

For power supply and command signal

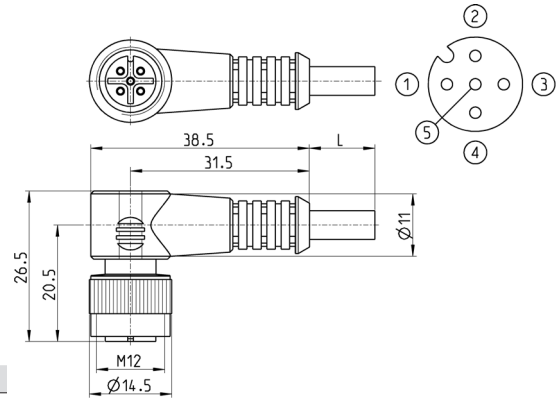

Mod.	Cable length (m)	Shielding	No. wires
CS-LR05HB-C200	2	Unshielded	5
CS-LR05HB-C500	5	Unshielded	5
CS-LR05HB-D200	2	Shielded	5
CS-LR05HB-D500	5	Shielded	5
CS-LR03HB-C200	2	Unshielded	3
CS-LR03HB-C500	5	Unshielded	3

Mounting brackets for DIN-rail PME

DIN EN 50022 (7,5mm x 35mm - width 1)



Supplied with:
2x mounting brackets
2x screws M4x6 UNI 5931
2x nuts

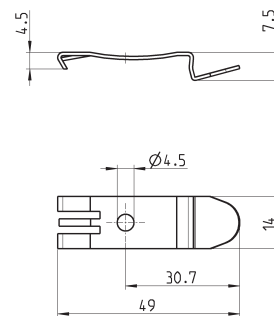

Mod.
PCF-EN531

Rear bracket Mod. PME



The kit includes
 1x zinc-plated bracket
 2x M4x55 white zinc-plated screws

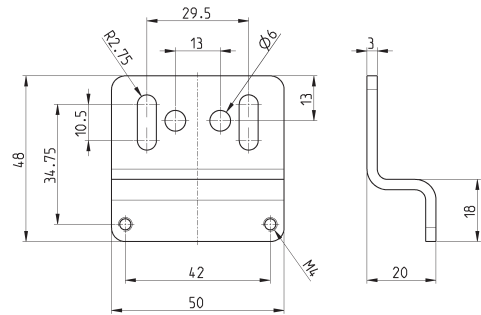

Mod.
PRE-ST

Fixing kit for manifold version: PME



The kit includes:
 2x shaped steel pins
 4x steel grub screws
 1x O-Ring

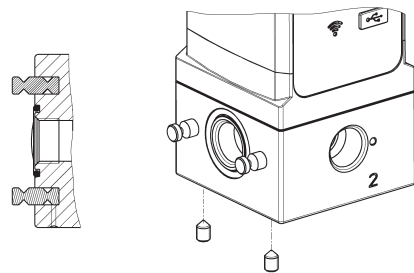

Mod.
PRE-M-PIN-1-2

Kit to fix PME on Series MD



The kit includes:
 1x bushing
 1x O-Ring
 2x special Ø4.5x34 white zinc-plated screws

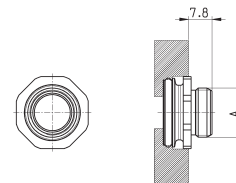

DIMENSIONS	
Mod.	A
PRE-1/4-C	G1/4
PRE-3/8-C	G3/8

Fittings for external pilot supply

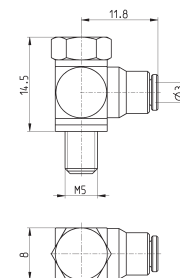

Mod.
6625 3-M5

Straight female M12, 5 pin connector

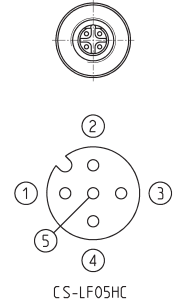
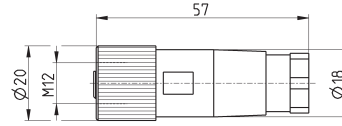

CS-LF05HC

Mod.
CS-LF05HC

Angular 90°, female M12, 5 pin connector

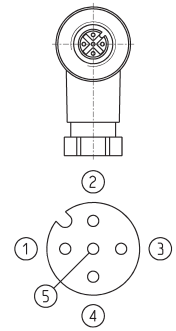
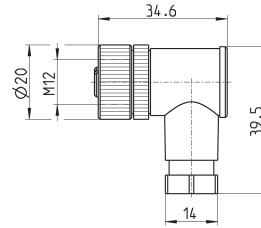

CS-LR05HC

Mod.
CS-LR05HC

CANopen data line tee

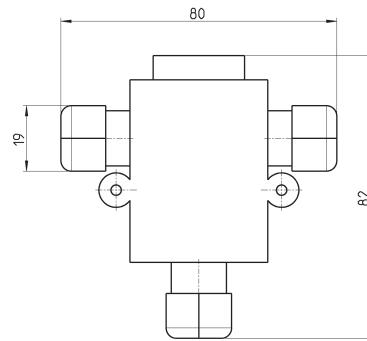

Mod.
CS-AA05EC