

# Manómetros Mod. M043.. - M053.. - M063..

MANÓMETROS



- » Conexiones radiales
- » Conexiones traseras
- » Montaje en panel

Para seleccionar el manómetro más adecuado, el rango de medida se debe elegir teniendo en cuenta el tipo de aplicación de acuerdo a los siguientes criterios:

1. Presión constante o presión con fluctuaciones lentas deben estar dentro del 75% de la escala de valor máxima.
2. Presión pulsante o fluctuaciones rápidas debe estar dentro del 65% del valor de la escala máxima.
3. Los picos de presión no deben exceder el valor de la escala máxima.

**Manómetro en miniatura**

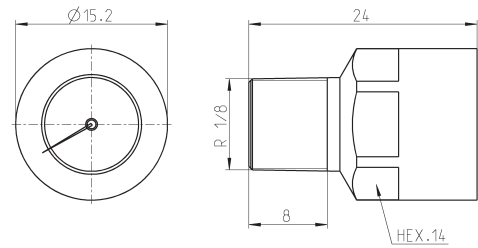

Mod.	Range
M015-P08	0 ÷ 8 bar

**Manómetros para montaje en panel**

Precisión clase CL1,6

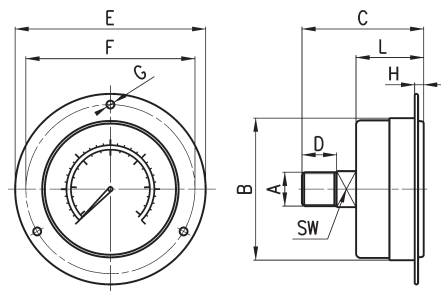

DIMENSIONES											
Mod.	A	B	C	D	E	F	G	H	L	SW	Escala
M043-F04	R1/8	∅ 40.5	43	10	61	51	∅ 3.5	4	27	12	0-4 bar
M043-F06	R1/8	∅ 40.5	43	10	61	51	∅ 3.5	4	27	12	0-6 bar
M043-F10	R1/8	∅ 40.5	43	10	61	51	∅ 3.5	4	27	12	0-10 bar
M043-F12	R1/8	∅ 40.5	43	10	61	51	∅ 3.5	4	27	12	0-12 bar
M063-F12	R1/4	∅ 63	54	12	85	75	∅ 3.5	4.5	30.5	14	0-12 bar

**Manómetros con conexión radial**

Clase de precisión CL1,6

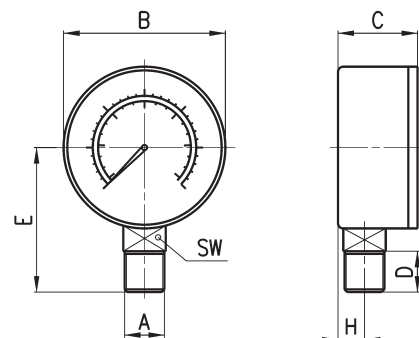

DIMENSIONES									
Mod.	A	B	C	D	E	H	SW	Escala	
M043-R06	R1/8	∅ 38.8	24.2	10	35.2	9	12	0-6 bar	
M043-R12	R1/8	∅ 38.8	24.2	10	35.2	9	12	0-12 bar	
M053-R12	R1/8	∅ 48.8	27.5	10	43	10	14	0-12 bar	
M063-R12	R1/4	∅ 63	28.8	12	50	10	14	0-12 bar	

## Manómetros con conexión posterior



Clase de precisión CL2,5  
\*No compatible con oxígeno

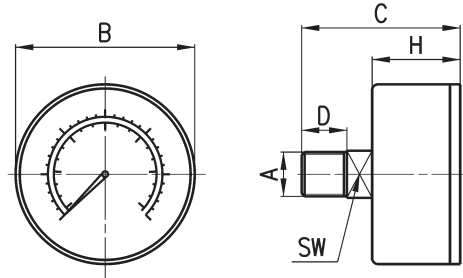

DIMENSIONES							
Mod.	A	B	C	D	H	SW	Escala
M043-P02,5	R1/8	Ø 38.8	41	10	25	14	0 ÷ 2.5 bar
M043-P04	R1/8	Ø 38.8	41	10	25	14	0 ÷ 4 bar
M043-P06	R1/8	Ø 38.8	41	10	25	14	0 ÷ 6 bar
M043-P10	R1/8	Ø 38.8	41	10	25	14	0 ÷ 10 bar
M043-P12	R1/8	Ø 38.8	41	10	25	14	0 ÷ 12 bar
M053-P04	R1/8	Ø 50	41.5	10	25	14	0 ÷ 4 bar
M053-P06	R1/8	Ø 50	41.5	10	25	14	0 ÷ 6 bar
M053-P10	R1/8	Ø 50	41.5	10	25	14	0 ÷ 10 bar
M053-P12	R1/8	Ø 50	41.5	10	25	14	0 ÷ 12 bar
M063-P04	R1/4	Ø 63	40.5	12	25	14	0 ÷ 4 bar
M063-P06	R1/4	Ø 63	40.5	12	25	14	0 ÷ 6 bar
M063-P12	R1/4	Ø 63	40.5	12	25	14	0 ÷ 12 bar

## Manómetro incorporado

**Nuevo modelo**



Clase de precisión CL4,0

Suministrado con:  
1x manómetro  
1x junta  
2x tornillos

Fig. 1 = manómetro  
Fig. 2 = asiento

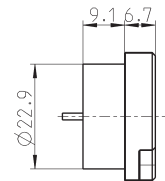
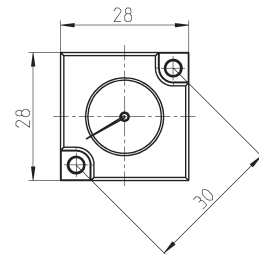

Fig. 1

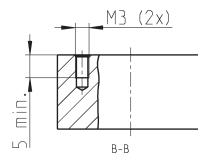
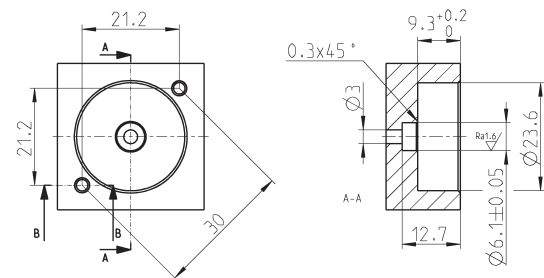

Fig. 2



Mod.	Range
MX3-R30/W-P	0 ÷ 12 bar
MX3-R31/W-P	0 ÷ 6 bar
MX3-R32/W-P	0 ÷ 10 bar
MX3-R33/W-P	0 ÷ 2.5 bar