

Series QCTF - QCBF cylinders with integrated guide

Double-acting, magnetic, with double bearings and flanges
 ø 20, 25, 32, 40 mm

SERIES QCTF - QCBF CYLINDERS



- » Magnetic sensors can be mounted on both sides
- » QCTF: bronze bushings
- » QCBF: ball bearing guide
- » Movement and guide in one unit

The end cushioning is available in three different variants:

- A. fixed mechanical cushion (standard)
- B. with two shock absorbers located on the body
- C. with one shock absorber located central on the rear flange.

The versions B and C are suitable for handling of higher mass forces and / or when it is necessary to adjust the stroke.

These cylinders have been designed to be used in applications where space is limited. Regarding the bearings, the Slide Units are available in two versions, one with double sintered bronze bushes (Mod. QCTF) and the other with double linear ball bearings (Mod. QCBF). The QCTF version would normally be selected when the side loads applied to the slide unit are high. Mod. QCBF is suitable for fast cycles (less side load) and higher precision.

GENERAL DATA

Type of construction	guided with double bearings and double flanges QCTF = sintered bronze bushes QCBF = linear ball bearings
Operation	double-acting
Materials	body = anodized AL flanges = zinc-plated steel piston rod = rolled stainless steel AISI QCTF columns = rolled stainless steel 420B QCBF columns = hardened steel C50 seals = PU
Mounting	threaded and non threaded holes in the body
Strokes min. max	(see table)
Operating temperature	0°C ÷ 80°C (with dry air -20°C)
Speed	50 ÷ 500 mm/s
Stroke end cushioning Type A	extended stroke - fixed mechanical cushioning retracted stroke - fixed mechanical cushioning we recommend preventing the piston from striking against the end covers
Stroke end cushioning Type B	extended stroke - shock absorber retracted stroke - shock absorber
Stroke end cushioning Type C	extended stroke - shock absorber retracted stroke - fixed mechanical cushioning we recommend preventing the piston from striking against the end covers
Operating pressure	1 ÷ 10 bar
Fluid	clean air, non lubricated. If lubricated air is used, it is recommended to use oil ISOVG32. Once applied the lubrication should never be interrupted.

STANDARD STROKES FOR DOUBLE-ACTING CYLINDERS SERIES QCTF AND QCBF

- = Type A and C Out of standard intermediate strokes available on request (strokes multiple of 5 mm)
- ✖ = Type B

STANDARD STROKES											
∅	20	25	30	40	50	75	100	125	150	175	200
20	■		■	■	■	■ ✖	■ ✖	■ ✖	■ ✖	■ ✖	■ ✖
25	■		■	■	■	■ ✖	■ ✖	■ ✖	■ ✖	■ ✖	■ ✖
32		■			■	■	■ ✖	■ ✖	■ ✖	■ ✖	■ ✖
40		■			■	■	■ ✖	■ ✖	■ ✖	■ ✖	■ ✖

CODING EXAMPLE

QC	T	F	2	A	020	A	050
QC	SERIES						
T	TYPE OF BEARING: T = sintered bronze bushes B = linear ball bearings						
F	VERSION: F = double flange						
2	OPERATION: 2 = double-acting					PNEUMATIC SYMBOL: CD14	
A	MATERIALS: A = anodized aluminium body - rolled stainless steel piston rod AISI 303 rolled stainless steel AISI 420B columns for QCTF - hardened steel C50 columns for QCBF						
020	BORE: 020 = 20 mm - 025 = 25 mm - 032 = 32 mm - 040 = 40 mm						
A	CUSHION: A = fixed mechanical cushion (standard) B = two shock absorbers located on the body C = one shock absorber located on the rear flange						
050	STROKE (see the table)						

SERIES QCTF - QCBF CYLINDERS

PNEUMATIC SYMBOLS

The pneumatic symbols which have been indicated in the CODING EXAMPLE are shown below.



TABLE OF PERMISSIBLE LOADS (F1)

For sintered bronze bushes
QCTF version
For linear ball bearings
QCBF version

F1 (N) 1N = 0.102 kgf

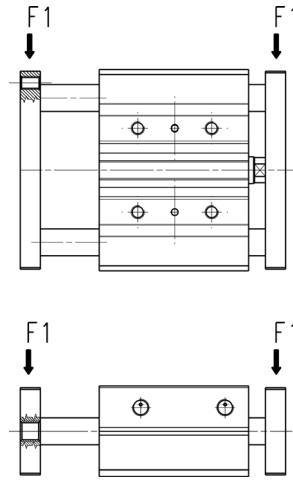

STROKE												
∅	20	25	30	40	50	75	100	125	150	175	200	
20	QCTF	136	-	124	124	123	122	122	121	121	120	120
	QCBF	146	-	142	140	139	137	136	134	94	70	53
25	QCTF	181	-	167	165	164	163	162	161	160	159	158
	QCBF	171	-	167	165	163	161	160	160	159	142	109
32	QCTF	-	174	-	-	166	162	160	158	156	155	153
	QCBF	-	220	-	-	214	211	211	210	210	209	209
40	QCTF	-	189	-	-	175	168	164	161	159	157	155
	QCBF	-	228	-	-	219	214	214	212	212	211	210

TABLE OF PERMISSIBLE MOMENTS (M1)

For sintered bronze bushes
QCTF version
For linear ball bearings
QCBF version

M1 (N*m) 1N*m = 0,102 kgf*m

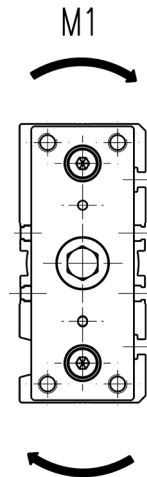

STROKE												
∅	Mod.	20	25	30	40	50	75	100	125	150	175	200
20	QCTF	3,6	-	3,3	3,3	3,3	3,2	3,2	3,2	3,2	3,2	3,2
	QCBF	3,9	-	3,7	3,7	3,7	3,6	3,6	3,6	2,5	1,89	1,4
25	QCTF	5,7	-	5,2	5,2	5,2	5,2	5,1	5,1	5,1	5	5
	QCBF	5,4	-	5,2	5,2	5,2	5,1	5,1	5,1	5	4,5	3,4
32	QCTF	-	6,7	-	-	6,4	6,3	6,2	6,1	6	6	5,9
	QCBF	-	8,5	-	-	8,3	8,2	8,2	8,1	8,1	8,1	8,1
40	QCTF	-	8,1	-	-	7,5	7,2	7	6,9	6,8	6,7	6,6
	QCBF	-	9,8	-	-	9,4	9,2	9,2	9,1	9,1	9	9

Mod. QCTF and QCBF type "A"



+ = add the stroke once
 ++ = add the stroke twice

Note: for out of standard intermediate strokes (ex. stroke 35), consider the immediately higher stroke dimensions (ex. stroke 40).

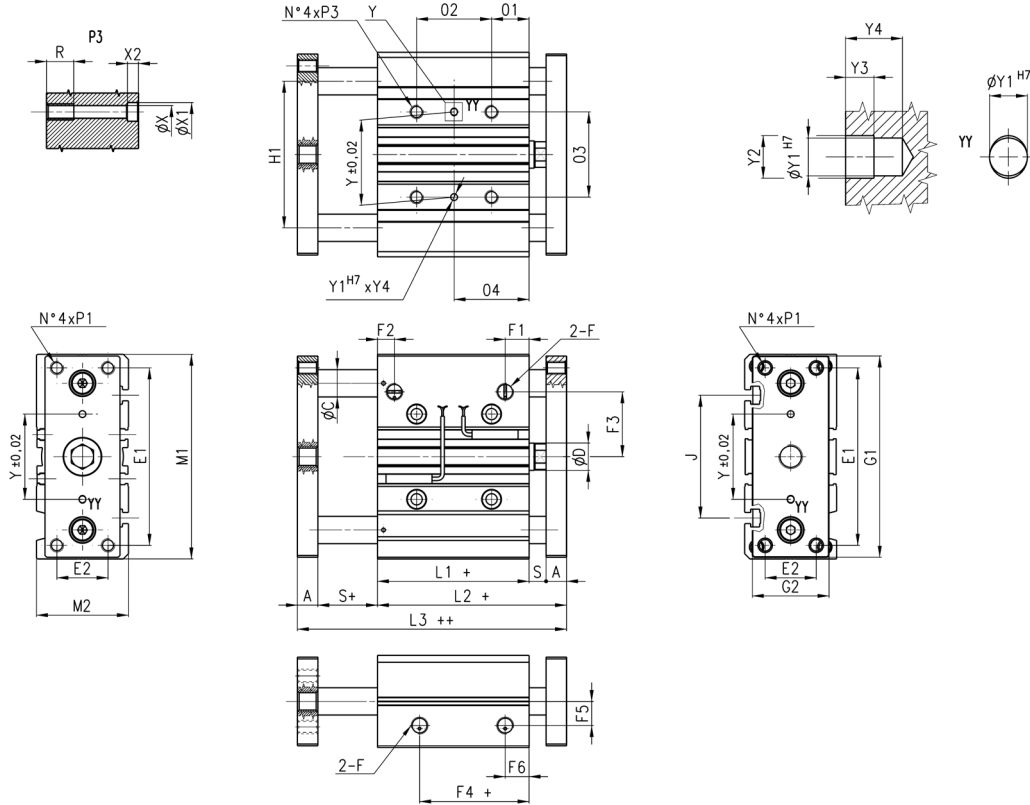

In case of use of lateral ports, unscrew the related threaded caps, screw them in the front ports and tighten them up to the cylinder surface (not tighter) having care to use a proper sealer.

DIMENSIONS											
\emptyset	P1	P3	Y1	Y2	Y3	Y4	X	X1	X2	J	K
20	M5x0,8	M6x1	3	3,5	3	6	5,5	9	5	44	M5
25	M6x1	M6x1	4	4,5	3	6	5,5	9	5	50	M5
32	M8x1,25	M8x1,25	4	4,5	3	6	6,5	11	6,5	63	M6
40	M8x1,25	M8x1,25	4	4,5	3	6	6,5	11	6,5	72	M6

	02 stroke 20-30	02 stroke 40-100	02 stroke 125-200	04 stroke 20-30	04 stroke 40-100	04 stroke 125-200	QCBF $\emptyset C$	QCTF $\emptyset C$
20	24	44	120	29	39	77	10	12
25	24	44	120	29	39	77	12	16
32	24	48	124	33	45	83	16	20
40	24	48	124	34	46	84	16	20

DIMENSIONS																								
\emptyset	A	ϕD	E1	E2	F	F1	F2	F3	F4	F5	F6	G1	G2	H1	L1	L2	L3	M1	M2	O1	O3	R	S	Y
20	10	10	70	18	1/8	10.5	10.5	25	12.5	11.5	10.5	81	30	54	37	53	69	83	36	17	28	12	6	28
25	10	12	78	26	1/8	11.5	8	28.5	12.5	13.5	11.5	91	40	64	37.5	53.5	69.5	93	42	17	34	12	6	34
32	12	16	96	30	1/8	12.5	9.5	34	7	15	12.5	110	45	78	37.5	59.5	81.5	112	48	21	42	16	10	42
40	12	16	104	30	1/8	13	12	38	13	18	13	118	45	86	44	66	88	120	54	22	50	16	10	50

Mod. QCTF and QCBF type "B"



+= add the stroke once
 += add the stroke twice

Note: for out of standard intermediate strokes (ex. stroke 35), consider the immediately higher stroke dimensions (ex. stroke 40).

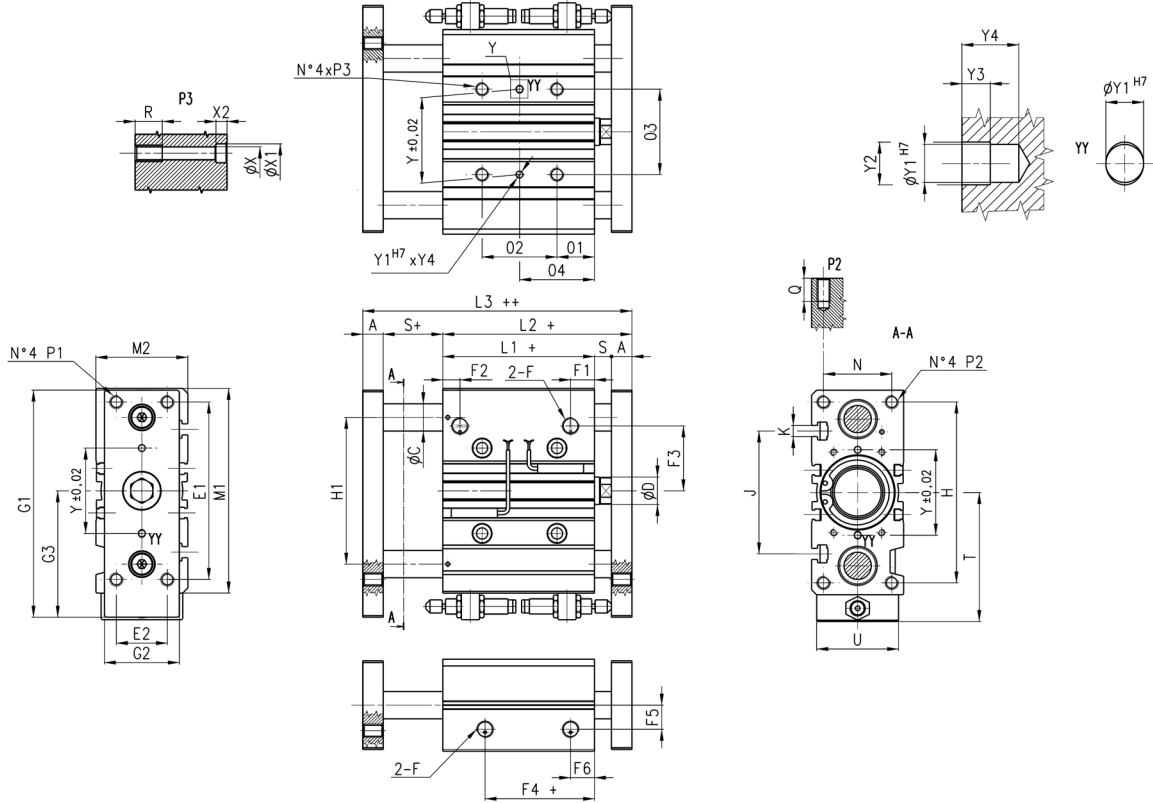

In case of use of lateral ports, unscrew the related threaded caps, screw them in the front ports and tighten them up to the cylinder surface (not tighter) having care to use a proper sealer.

DIMENSIONS																	
Ø	P1	P3	T	U	Y	Y1	Y2	Y3	Y4	X	X1	X2	J	K	Shock absorber	Δ stroke (mm)	adjustment range cyl. stroke mm
20	M5x0,8	M6x1	57,5	32	28	3	3,5	3	6	5,5	9	5	44	M5	SA-1007	0 ÷ 15	0 ÷ +12
25	M6x1	M6x1	62,5	38	34	4	4,5	3	6	5,5	9	5	50	M5	SA-1007	0 ÷ 15	0 ÷ +8
32	M8x1,25	M8x1,25	81	44	42	4	4,5	3	6	6,5	11	6,5	63	M6	SA-1412	0 ÷ 20	0 ÷ +10
40	M8x1,25	M8x1,25	85	44	50	4	4,5	3	6	6,5	11	6,5	72	M6	SA-1412	0 ÷ 20	0 ÷ +11
	02 stroke 75	02 stroke 100	02 stroke 125-200		04 stroke 20-30	04 stroke 40-100	04 stroke 125-200		QCBF ØC	QCTF ØC							
20	44	44	120		29	39	77		10	12							
25	44	44	120		29	39	77		12	16							
32	-	48	124		33	45	83		16	20							
40	-	48	124		34	46	84		16	20							

DIMENSIONS																										
Ø	A	ØD	E1	E2	F	F1	F2	F3	F4+	F5	F6	G1	G2	G3	H1	L1+	L2+	L3++	M1	M2	O1	O3	R	S		
20	10	10	70	18	1/8	10,5	10,5	25	12,5	11,5	10,5	97	30	56,5	54	37	53	69	83	36	17	28	12	6		
25	10	12	78	26	1/8	11,5	8	28,5	12,5	13,5	11,5	107	40	61,5	64	37,5	53,5	69	93	42	17	34	12	6		
32	12	16	96	30	1/8	12,5	9,5	34	7	15	12,5	134	45	79	78	37,5	59,5	81,5	112	48	21	42	16	10		
40	12	16	104	30	1/8	13	12	38	13	18	13	141	45	82	86	44	66	88	120	54	22	50	16	10		

