

Series 8 pneumatic operated cartridge valves

2/2-way - Normally Closed (NC)

SERIES 8 CARTRIDGE VALVES



- » Use with oxygen
- » Suitable also for general purpose
- » Compact design
- » High flow
- » Manifold assembly

Series 8 pneumatic operated valves are particularly suitable for applications requiring high flow combined with compact design. The valve is pneumatic operated by electro-pilots which are dimensioned according to the size. The cartridge design, which is ideal for manifold assembly, allows to reduce both dimensions and the number of pneumatic connections.

The standard function of the valve is 2/2-way NC. It can however fulfill the 3/2-way NC function if inserted in a proper seat (see the following pages).

GENERAL DATA

TECHNICAL FEATURES

Function	2/2 NC
Operation	pneumatic operated poppet type
Pneumatic connections	manifold cartridge
Nominal diameter	5 ... 9 mm
Nominal flow	420 ... 1480 Nl/min (air at 6 bar ΔP 1 bar)
Flow coefficient kv (l/min)	6.5 ... 23
Operating pressure	3 ÷ 6 bar (0 ÷ 6 bar with external pilot supply)
Operating temperature	0 ÷ +50°C
Media	filtered air, class 5.4.4 according to ISO 8573-1 (max oil viscosity 32 cSt), inert gas
Response time (ISO 12238)	ON <10 msec - OFF <10 msec
Installation	in any position

MATERIALS IN CONTACT WITH THE MEDIUM

Body	brass
Internal parts	aluminium
Seals	FKM

CODING EXAMPLE

8	10	C5	1	00	-	F1	3	2	-	OX2
8	SERIES									
10	SIZE: 10 = Size 1 20 = Size 2 30 = Size 3									
C5	BODY DESIGN: C5 = cartridge									
1	NUMBER OF WAYS - FUNCTIONS: 1 = 2/2-way NC or 3/2-way NC NOTE: The function depends on the seat used (for further details see the following pages)									
00	PNEUMATIC CONNECTIONS: 00 = cartridge									
F1	NOMINAL DIAMETER: F1 = \varnothing 5.0 mm (size 1 only) G7 = \varnothing 6.6 mm (size 2 only) K1 = \varnothing 9.0 mm (size 3 only)									
3	SEAL MATERIAL: 3 = FKM									
2	BODY MATERIAL: 2 = brass									
OX2	OX2 = for use with oxygen (non volatile residual less than 33 mg/m ³) NOTE: the OX2 suffix must be added also in case of use with air/gas.									

Pneumatic cartridge valve 2/2-way NC



For 2/2-way (pneumatic symbol VP14) or 3/2-way (pneumatic symbol YES1) function, see the seat dimensioning in the next pages.

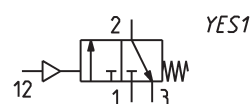
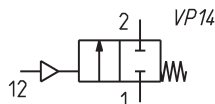
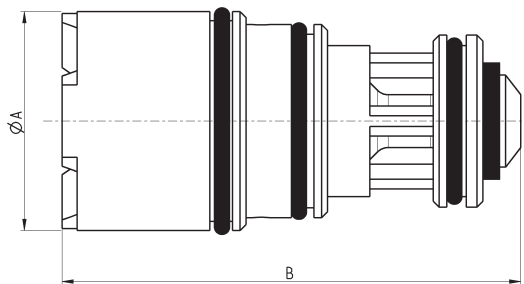

Mod.	ØA	B	Nominal diameter Ø (mm)	kv (l/min)	Qn (NL/min)	Min/max pressure (bar)	Min/max pilot pressure (bar)
810C5100-F132-OX2	10	26.7	5.0	6.5	420	0 ÷ 6	3 ÷ 6
820C5100-G732-OX2	14.5	30.3	6.6	12.5	800	0 ÷ 6	3 ÷ 6
830C5100-K132-OX2	22	34.8	9.0	23	1480	0 ÷ 6	3 ÷ 6

Seat for Series 8 pneumatic valve with 2/2-way NC function

NOTE IN THE DRAWING:
1 = inlet
2 = outlet
12 = pilot supply
R = poppet chamber exhaust

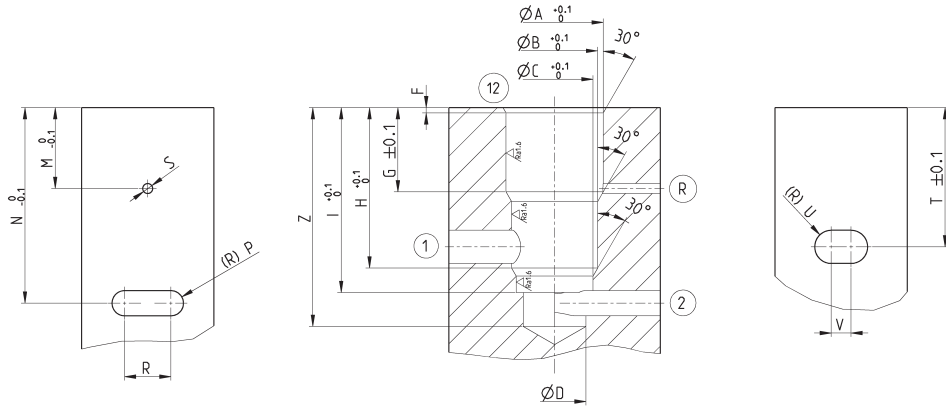

SERIES 8																	
Size	A	B	C	D	F	G	H	I	M	N	P	R	S	T	U	V	Z
1	10.4	9.7	9	8.2	0.8	14.5	20.7	25	13.2	26.2	1.5	5	1.5	19.1	3	5	30
2	14.65	12.95	11.55	9.5	0.8	12.8	24.2	27.9	12.2	29.3	1.9	7	1.5	20.5	2.5	4	33
3	22.1	20.6	19.6	16.2	0.5	15	28.7	33.4	12.5	37.1	4	4.4	2.5	24.8	3.75	5	41

Seat for Series 8 pneumatic valve with 3/2-way NC function

NOTE IN THE DRAWING:
1 = inlet
2 = outlet
3 = exhaust
12 = pilot supply
R = poppet chamber exhaust

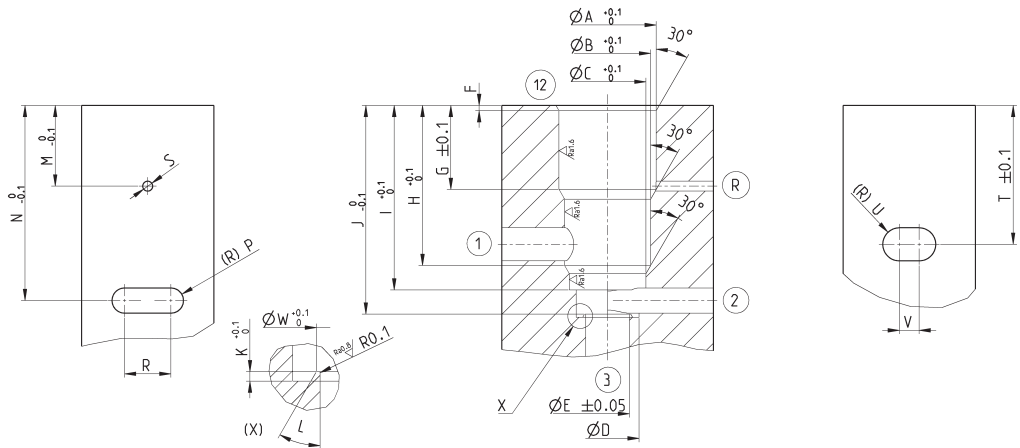

SERIES 8																					
Size	A	B	C	D	E	F	G	H	I	J	K	L	M	N	P	R	S	T	U	V	W
1	10.4	9.7	9	8.2	5	0.8	14.5	20.7	25	28	0.3	45	13.2	26.2	1.5	5	1.5	19.1	3	5	5.4
2	14.65	12.95	11.55	9.5	6.6	0.8	12.8	24.2	27.9	31.55	0.5	45	12.2	29.3	1.9	7	1.5	20.5	2.5	4	7
3	22.1	20.6	19.6	16.2	9	0.5	15	28.7	33.4	38.05	1	60	12.5	37.1	4	4.4	2.5	24.8	3.75	5	10