

# Series LR digital proportional servo valves

3/3-way directly operated servo valves for the flow (LRWD2), pressure (LRPD2) and position (LRXD2) control



- » Digital version which is completely configurable through micro USB
- » Rotating spool system with a metal to metal seal
- » High flow rate
- » Electronic control to ensure high precision in the flow control
- » 3-way-function with 4 - 6 mm nominal diameters
- » Compact version for cabinet mounting on DIN-rail
- » Position control version

Series LR digital proportional servo valves are direct driven 3/3-way valves with a patented rotating spool system with closed loop control circuit. The electronic board is integrated into the valve's body ready to connect.

Series LR\*D2 digital proportional servo valve has been designed to be as compact as possible in order to save space and to be mounted on a DIN-rail. Thanks to this new digital version, the valve can be configured through a USB connection according to different requirements.

## GENERAL DATA

Power supply	24 V DC +/- 10%, max absorption 1.5 A
Command signal	+/- 10 V 0-10 V 4-20 mA
Hysteresis	1% FS LRWD2 - 0,2% FS LRPD2
Linearity	1% FS LRWD2 - 0.3% FS LRPD2
Switching time	see the following pages
Working temperature	from 0 to 50° C
Relative humidity of air	max. 90%
Direction of assembly	any
Maximum flow	see the diagrams on the following pages
Medium	filtered compressed air, unlubricated, according to ISO 8573-1 class 3.4.3, inert gas
Supply pressure	-0.9 to 10 bar
Leakage	< 1% of maximum flow rate
Electrical connection	male connector M12 8 poles
Hardware configuration port	micro USB

**CODING EXAMPLE**

<b>L</b>	<b>R</b>	<b>W</b>	<b>D</b>	<b>2</b>	<b>-</b>	<b>3</b>	<b>4</b>	<b>-</b>	<b>1</b>	<b>-</b>	<b>A</b>	<b>-</b>	<b>00</b>
----------	----------	----------	----------	----------	----------	----------	----------	----------	----------	----------	----------	----------	-----------

<b>L</b>	SERIES: L = proportional servo valves	
<b>R</b>	TECHNOLOGY: R = rotating spool	
<b>W</b>	VERSION: W = flow control P = pressure control X = position control	
<b>D</b>	ELECTRONICS: D = digital	
<b>2</b>	MODEL: 2 = compact DIN-RAIL	
<b>3</b>	FUNCTION: 3 = 3/3-way	
<b>4</b>	NOMINAL DIAMETER: 4 = 4 mm 6 = 6 mm	
<b>1</b>	COMMAND SIGNAL (Setpoint): 1 = +/- 10 V 2 = 0 - 10 V 5 = 4 - 20 mA	
<b>A</b>	INPUT SIGNAL: 2 = 0 - 10 V (LRPD2 and LRXD2 only) 4 = 0 - 5V (LRPD2 and LRXD2 only) 5 = 4 - 20mA (LRPD2 and LRXD2 only)	A = internal encoder (LRWD2 only) B = 1 bar (internal sensor - LRPD2 only) D = 10 bar (internal sensor - LRPD2 only) E = 250 mbar (internal sensor - LRPD2 only) F = +1/-1 bar (internal sensor - LRPD2 only)
<b>00</b>	CABLE: 00 = no cable	2F = straight cable of 2 m 2R = 90° cable of 2 m 5F = straight cable of 5 m 5R = 90° cable of 5 m

SERIES LR DIGITAL PROPORTIONAL SERVO VALVES

**FLOW DIAGRAMS FOR VALVES LRWD2-34 AND LRWD2-36**

**LEGEND:**

- A = free flow
- B = ΔP1
- Q = flow (Nl/min)
- S = set point (%)
- Pa = inlet pressure (bar)

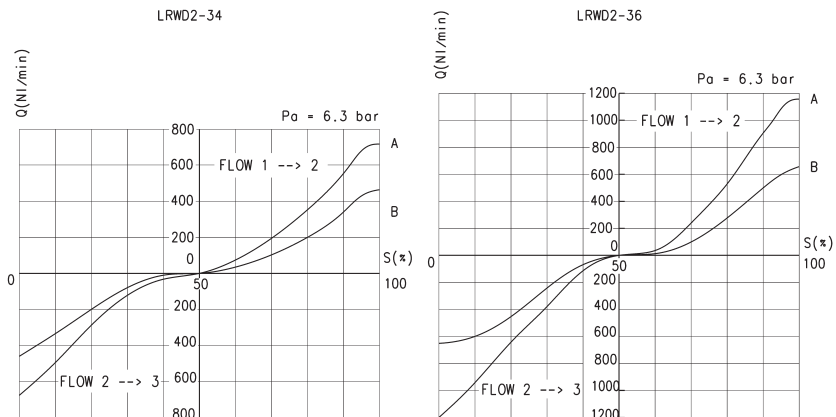

RESPONSE TIMES ACCORDING TO THE COMMAND SIGNAL IN COMPLIANCE WITH THE ISO 10094-2 STANDARD						
COMMAND SIGNAL	-5% ÷ +5%	+5% ÷ -5%	-25% ÷ +25%	+25% ÷ -25%	-90% ÷ +90%	+90% ÷ -90%
Time [ms] LRWD2-34	4	5	6	9	10	10
Time [ms] LRWD2-36	5	5	6	6	10	10

\* closed valve with SET POINT = 0  
loaded valve with SET POINT = +  
exhaust valve with SET POINT = -

### FLOW DIAGRAMS FOR VALVE LRPD2-34

LEGEND:  
P = regulated pressure (bar)  
F = flow (NL/min)  
Pa = inlet pressure (bar)

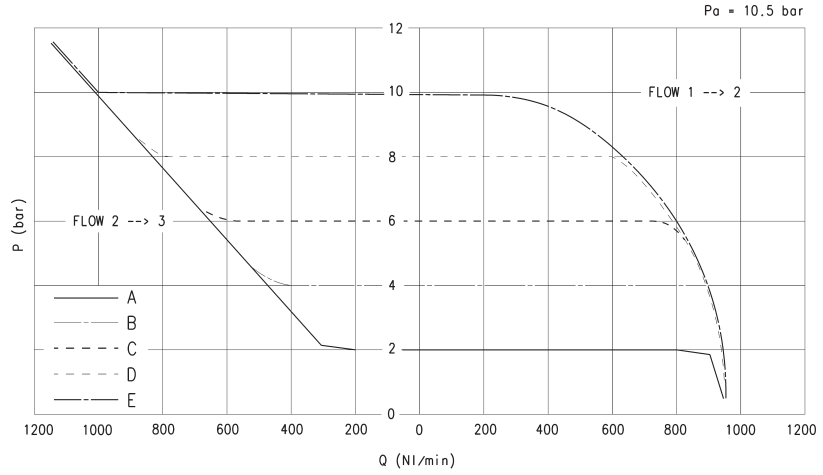

RESPONSE TIMES WITH COMMAND SIGNAL BETWEEN 0% AND 100% IN COMPLIANCE WITH ISO 10094-2 STANDARD

	Without volume	Volume 0,5 l	Volume 2 l
Filling [ms]	24	313	1841
Exhaust [ms]	35	663	3640

valve with SET POINT = 0% and regulated pressure = 0 bar

valve with SET POINT = 100% and regulated pressure = maximum pressure  
(example: 10 - 1 bar or 250 mbar)

### FLOW DIAGRAMS FOR VALVE LRPD2-36

LEGEND:  
P = regulated pressure (bar)  
F = flow (NL/min)  
Pa = inlet pressure (bar)

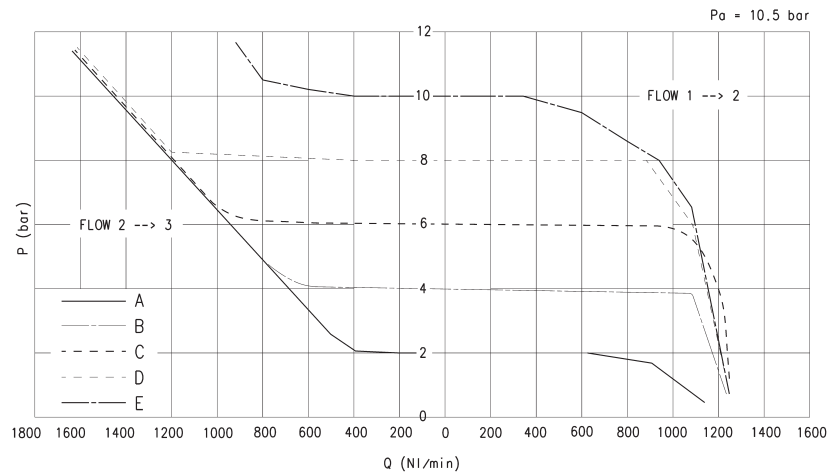

RESPONSE TIMES WITH COMMAND SIGNAL BETWEEN 0% AND 100% IN COMPLIANCE WITH ISO 10094-2 STANDARD

	Without volume	Volume 0,5 l	Volume 2 l
Filling [ms]	20	263	1560
Exhaust [ms]	32	357	1905

valve with SET POINT = 0% and regulated pressure = 0 bar

valve with SET POINT = 100% and regulated pressure = maximum pressure  
(example: 10 - 1 bar or 250 mbar)

### Series LRXD2 - pneumatic and electrical schemes for the installation

The LRXD2 servo valves are proportional valves with a high-precision integrated control for the positioning of pneumatic cylinders. The valves include a patented 3-way system based on the rotating spool principle with electronic control of the spool position. The servo pneumatic closed loop system allows the control of the position through the feedback of the external positioning sensor or of the Camozzi 6PF cylinder with the integrated linear transducer.

The electronic board which is integrated in the valve body manages speed and acceleration directly.

The Master valve Mod. LRXD2 is equipped with a proper signal to command a LRXD2 valve that will work as a slave-valve.

Configuration for the position control with two valves (Fig. 1)

A = Slave LRXD2-3\*-2-A-00 - B = Master LRXD2-3\*-4-00 - C = 6PF cylinder...

Configuration for the position control with a LRXD2 valve (Fig. 2)

A = Master LRXD2-3\*-4-00 - B = PR104... - C = 6PF cylinder...

Fig.1

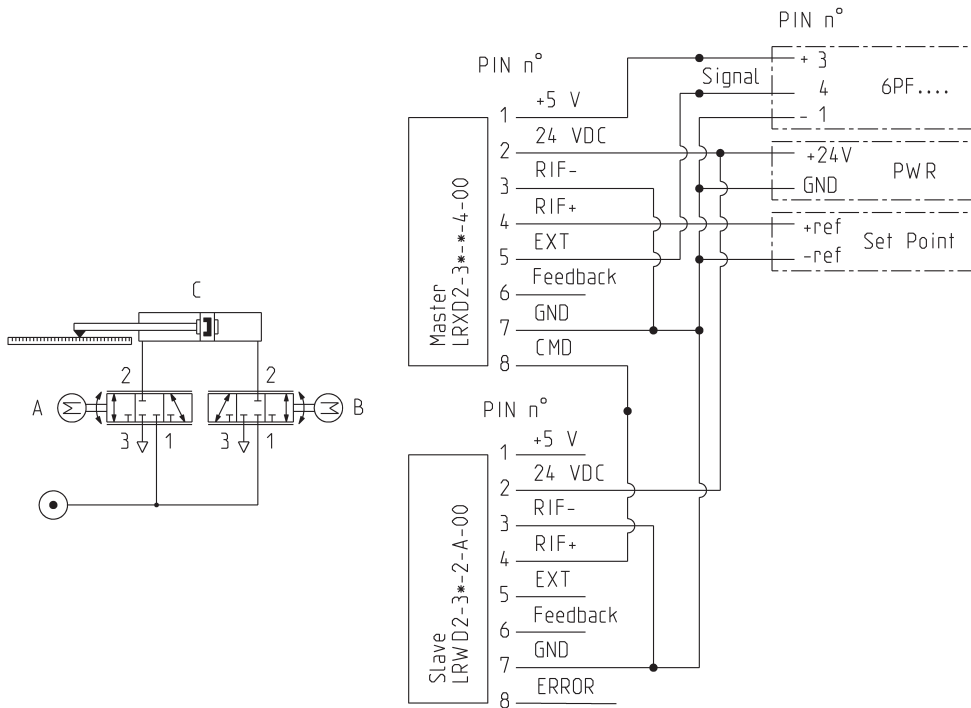
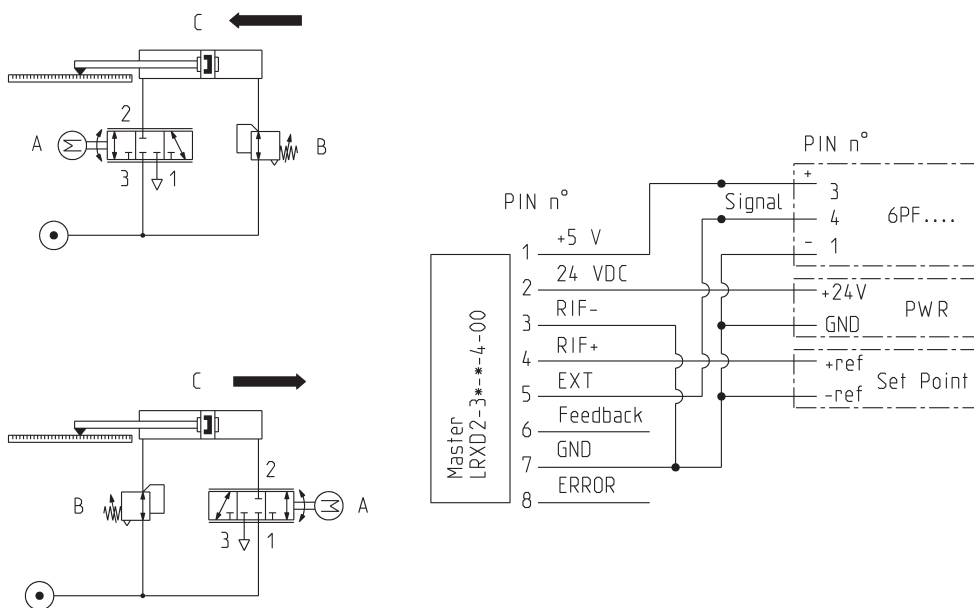
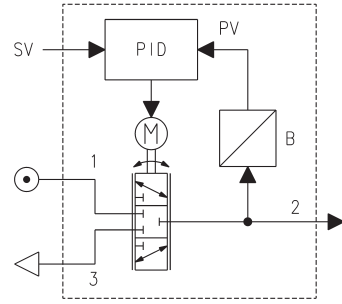
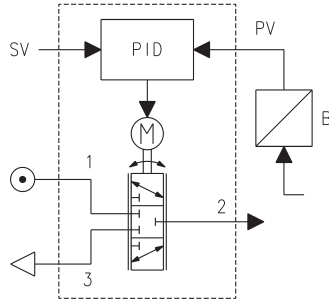

Fig.2



**Series LRPD2 - pneumatic scheme for the installation**

SV = setpoint value  
 PV = process value  
 B = sensor  
 PID = proportional control, integrative, derivative



## Series LR digital proportional servo valves - dimensions

The detailed user and maintenance manual and the Hardware configuration Software of the valve is available online at <http://catalogue.camozzi.com>.

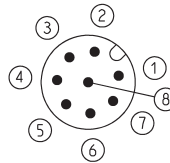
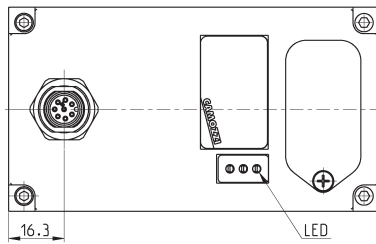
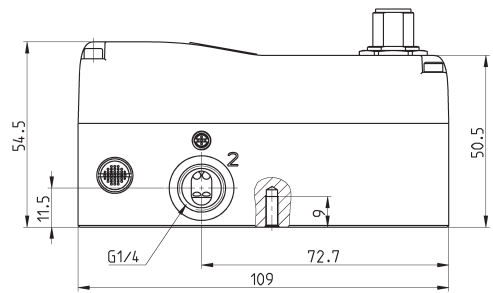
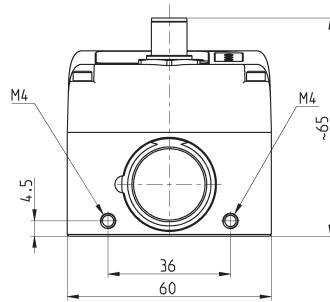
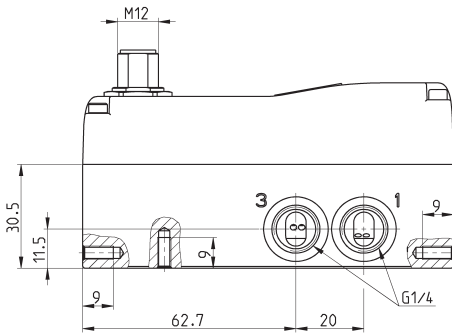
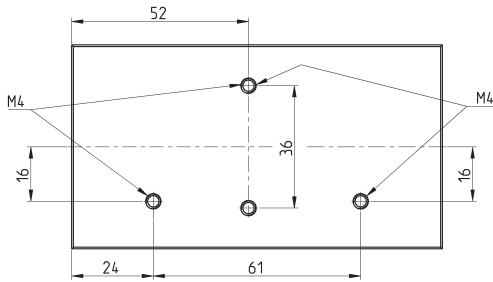
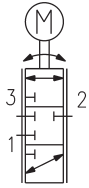

PIN	SIGNAL	DESCRIPTION
1	+5V	+5V power supply for external potentiometer transducer (ref. GND). If used, it is necessary to connect RIF- with GND.
2	24 V DC	24V DC power supply (logic and motor): connect to the positive pole of the 24V DC power supply (ref. GND)
3	RIF-	GND reference or NEGATIVE pole of the command signal (0-10V / 4-20mA / ±10V)
4	RIF+	POSITIVE reference of the command signal (0-10V / 4-20mA / ±10V)
5	EXT	for LRWD valve: not used for LRXD valve: feedback signal of the external transducer 0-5V / 0-10V / 4-20mA (ref. RIF-) for LRPD valve: feedback signal of the external transducer 0-5V / 0-10V / 4-20mA (ref. RIF-). To be used only with LRPD2 valve versions with external sensor.
6	FBK	feedback signal 0-10V / 4-20mA (ref. GND)
7	GND	common (reference pin 1 and 2): connect to the negative pole of the 24V DC power supply (compulsory)
8	ERR	for LRWD and LRPD valve: error signal (output) 0-24V (ref. GND) for LRXD valve: command signal 0-10V for slave valve (ref. GND)

## Series LR digital proportional servo valves - technical characteristics



\* To order the complete code, please replace the asterisk with 4 or 6 according to the desired nominal diameter.

SERIES LR DIGITAL PROPORTIONAL SERVO VALVES

Mod.	Control	Command/Input signal	Sensor/External signal	
LRWD2-3*-1-A-00	flow	+/- 10 V	-	
LRWD2-3*-2-A-00	flow	0-10 V	-	
LRWD2-3*-5-A-00	flow	4..20 mA	-	
LRPD2-3*-1-2-00	pressure	+/- 10 V	0..10 V	
LRPD2-3*-2-2-00	pressure	0-10 V	0..10 V	
LRPD2-3*-5-2-00	pressure	4..20 mA	0..10 V	
LRPD2-3*-1-4-00	pressure	+/- 10 V	0 - 5 V	
LRPD2-3*-2-4-00	pressure	0-10 V	0 - 5 V	
LRPD2-3*-5-4-00	pressure	4..20 mA	0 - 5 V	
LRPD2-3*-1-5-00	pressure	+/- 10 V	4..20 mA	
LRPD2-3*-2-5-00	pressure	0-10 V	4..20 mA	
LRPD2-3*-5-5-00	pressure	4..20 mA	4..20 mA	
LRPD2-3*-1-B-00	pressure	+/- 10 V	1 bar internal	
LRPD2-3*-2-B-00	pressure	0-10 V	1 bar internal	
LRPD2-3*-5-B-00	pressure	4..20 mA	1 bar internal	
LRPD2-3*-1-D-00	pressure	+/- 10 V	10 bar internal	
LRPD2-3*-2-D-00	pressure	0-10 V	10 bar internal	
LRPD2-3*-5-D-00	pressure	4..20 mA	10 bar internal	
LRPD2-3*-1-E-00	pressure	+/- 10 V	250 mbar internal	
LRPD2-3*-2-E-00	pressure	0-10 V	250 mbar internal	
LRPD2-3*-5-E-00	pressure	4..20 mA	250 mbar internal	
LRPD2-3*-1-F-00	pressure	+/- 10 V	+1/-1 bar internal	
LRPD2-3*-2-F-00	pressure	0-10 V	+1/-1 bar internal	
LRPD2-3*-5-F-00	pressure	4..20 mA	+1/-1 bar internal	
LRXD2-3*-1-4-00	position	+/- 10 V	0-5 V	suitable to work with the 6PF cylinder (see the PNEUMATIC ACTUATION catalogue)
LRXD2-3*-2-4-00	position	0-10 V	0-5 V	suitable to work with the 6PF cylinder (see the PNEUMATIC ACTUATION catalogue)
LRXD2-3*-5-4-00	position	4..20 mA	0-5 V	suitable to work with the 6PF cylinder (see the PNEUMATIC ACTUATION catalogue)
LRXD2-3*-1-2-00	position	+/- 10 V	0-10 V	
LRXD2-3*-2-2-00	position	0-10 V	0-10 V	
LRXD2-3*-5-2-00	position	4..20 mA	0-10 V	
LRXD2-3*-1-5-00	position	+/- 10 V	4..20mA	
LRXD2-3*-2-5-00	position	0-10 V	4..20mA	
LRXD2-3*-5-5-00	position	4..20mA	4..20mA	

### Fixing foot Mod. LRADB



Supplied with:  
2x feet  
4x screws

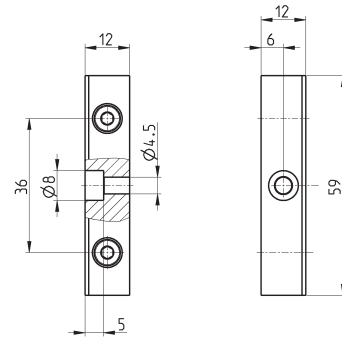

Mod.  
**LRADB**

### Mounting brackets for DIN-rail Mod. PCF-EN531



DIN EN 50022 (7,5mm x 35mm - width 1)

Supplied with:  
2x mounting brackets  
2x screws M4x6 UNI 5931  
2x nuts

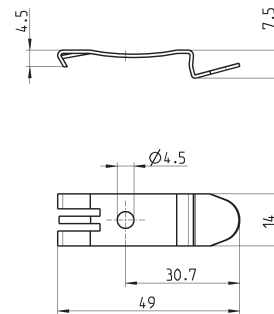

Mod.  
**PCF-EN531**

### Electrical tee box Mod. CS-AA08EC



Connection valve-PLC-external transducer

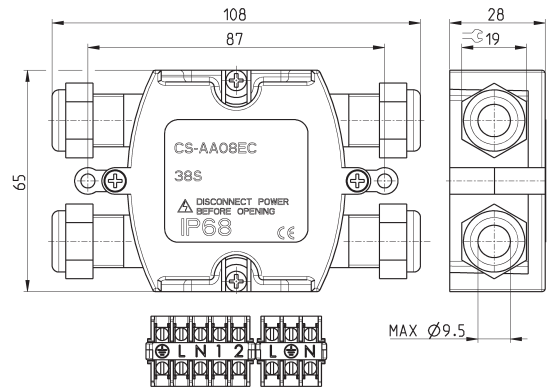

**CS-AA08EC**

### Straight female connector M12 8 poles



For electric supply and commands

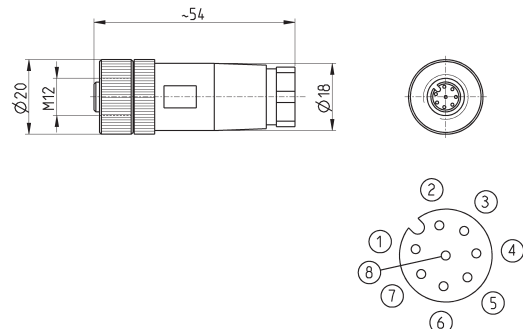

**CS-LF08HC**



**Cable with straight female connector M12 8 poles**



For electrical supply and commands

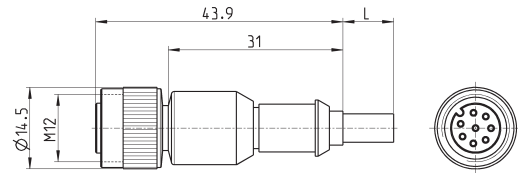

Mod.	Cable length (m)
CS-LF08HB-C200	2
CS-LF08HB-C500	5

**Cable with angular (90°) female connector M12 8 poles**



For electric supply and commands

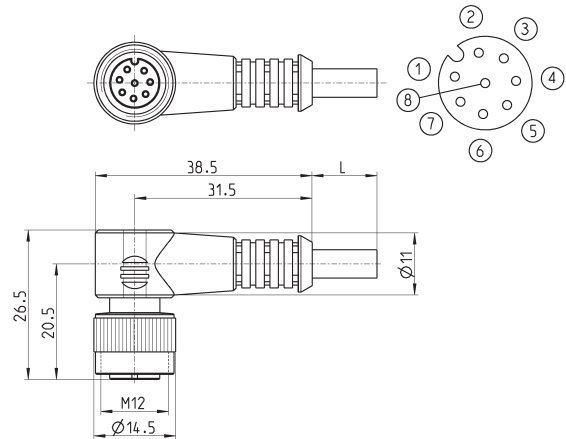

Mod.	Cable length (m)
CS-LR08HB-C200	2
CS-LR08HB-C500	5

**USB to Micro USB cable Mod. G11W-G12W-2**



For the hardware configuration of the Camozzi products

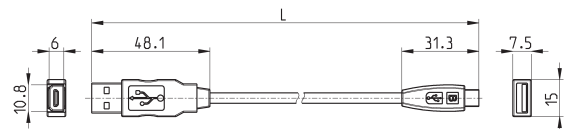

Mod.	description	connections	material for outer sheath	cable length "L" (m)
G11W-G12W-2	black shielded cable 28 AWG	standard USB to Micro USB	PVC	2