

New

Series CGPM self-centering Parallel grippers with H-shaped guide

Single and double acting, magnetic, self-centering
Bores: 12, 16, 25, 35, 45
Standard stroke or long stroke



- » Robust, compact and light design
- » High reliability
- » High closing/opening repeatability
- » High interchangeability (gripper positioning precision)
- » Position detection thanks to magnetic proximity switches
- » Free from Copper, Silicone and PTFE
- » IP 40 and IP 20

Series CGPM are self-centering, parallel grippers, guided by means of an H-shaped sliding guide.

The series is available in 5 sizes with different strokes.

Thanks to the materials and surface coating used, the gripper offers a high performance over time, enhanced reliability and protection against the entrance of impurities.

Extreme compact dimensions, high repeatability and the opening and closing speed make the Series CGPM particularly suitable in applications like pick & place, insertion and machine tending, that are typically found in the Assembly sector. These pneumatic grippers are mainly used on automatic machines that require high production cycles and very precise positioning.

GENERAL DATA

Type of construction	Self-centering parallel gripper with H-guide
Operation	Single acting (NO, NC), double acting
Bores	12, 16, 25, 35, 45
Force transmission	Lever
Air connections	M3 (12), M5 (16), G 1/8 (25, 35, 45)
Working pressure	2 ÷ 8 bar (double acting), 4 ÷ 8 bar (single acting), 3 ÷ 8 bar (12)
Working temperature	5°C ÷ 60°C (standard)
Store temperature	5°C ÷ 90°C
Maximum use frequency	4 Hz (12, 16, 25), 3 Hz (35, 45)
Repeatability	0.02 mm
Interchangeability	0.1 mm
Medium	Filtered air in class [7:4:4] according to ISO 8573-1. In case lubricated air is used, we recommend ISOVG32 oil and to never interrupt lubrication.
Lubrication	After 10 million cycles, grease the sliding zones using Molykote DX grease.
Protection class	IP 40 IP 20
Compatibility	ROHS Directive
Certifications	ATEX (II 2GD c IIC 120°C(T4)-20°C≤T _a ≤80)
Materials	PTFE, Silicone and Copper free

N.B. Pressurize the pneumatic system gradually in order to avoid uncontrolled movements

CODING EXAMPLE

CGPM	-	12	L	-	NC	-	EX
-------------	---	-----------	----------	---	-----------	---	-----------

CGPM	SERIES	
12	BORES: 12 16 25 35 45	
L	STROKE: = standard L = long stroke	
NC	FUNCTIONING: = double acting NO = single acting, normally open NC = single acting, normally closed	PNEUMATIC SYMBOLS PNZ1 PNZ3 PNZ2
EX	Add EX to order the certified ATEX version	

PNEUMATIC SYMBOLS

The pneumatic symbols which have been indicated in the CODING EXAMPLE are shown below.

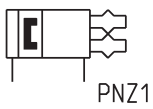

Series CGPM grippers - construction

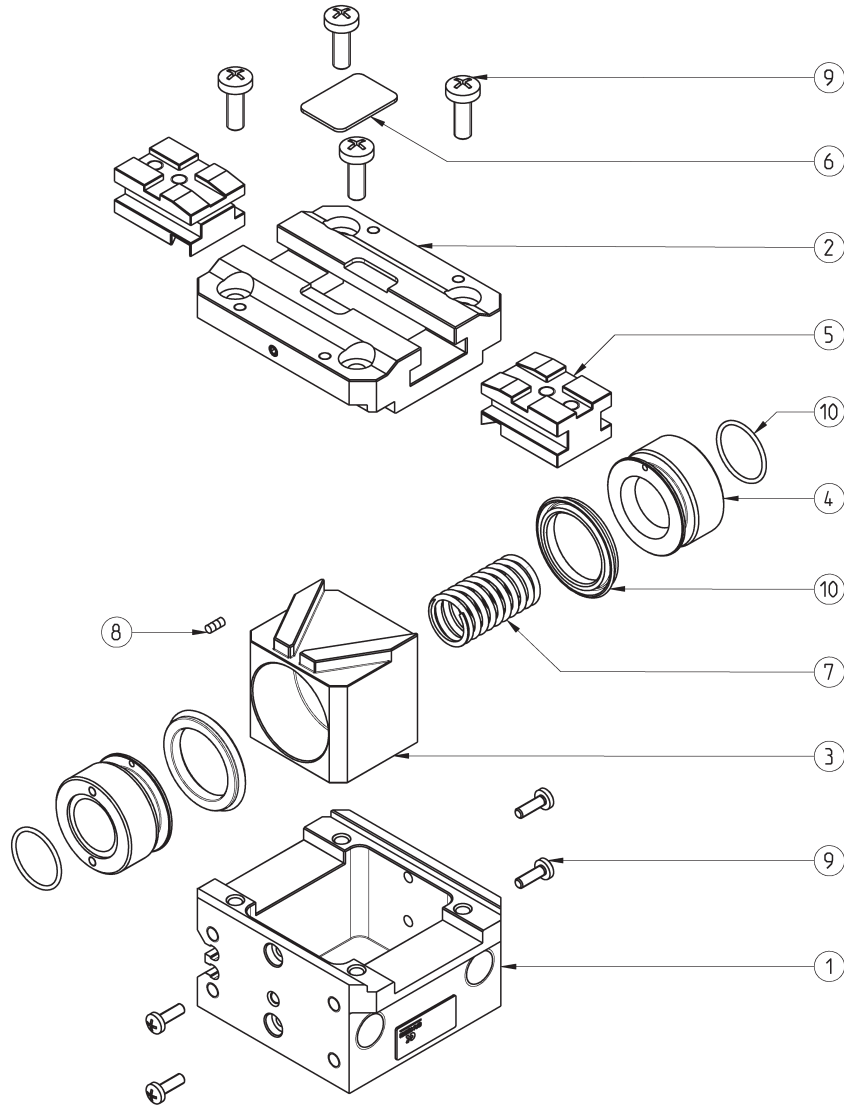

LIST OF COMPONENTS	
PARTS	MATERIALS
1 - Body	Aluminium
2 - Guide	Aluminium
3 - Slider	Aluminium
4 - Piston	Aluminium
5 - Jaw	Stainless steel
6 - Cover	Stainless steel
7 - Spring	Steel
8 - Magnet	Neodymium
9 - Screws	Stainless steel
10 - Seals	NBR

CGPM gripper, size 12 - dimensions

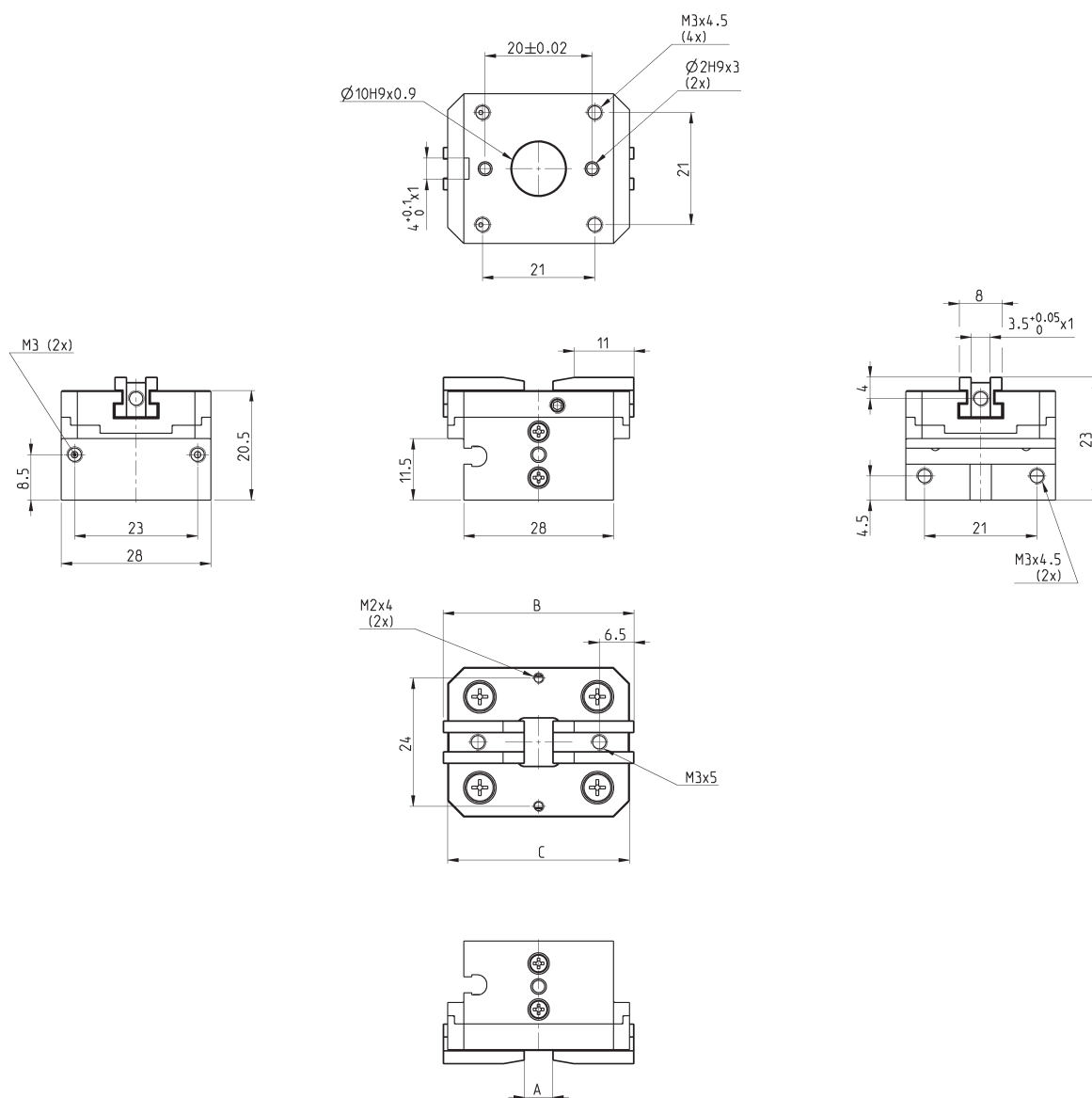

Mod.	Total closing grippin force at 6 bar (N)	Closing grippin force each jaw at 6 bar (N)	Total opening grippin force at 6 bar (N)	Opening grippin force each jaw at 6 bar (N)	Total stroke A (mm)	Open gripper B (mm)	C (mm)	Working Pressure (bar)	Working Temperature (°C)	Repeatability (mm)	Max use frequency (Hz)	Weight (Kg)
CGPM-12	76	38	76	38	5.3	35.7	34	3 ÷ 8	5 ÷ 60	0.02	4	0,47
CGPM-12-NC	90	45	50	25	5.3	35.7	34	4 ÷ 8	5 ÷ 60	0.02	4	0,48
CGPM-12-NO	50	25	90	45	5.3	35.7	34	4 ÷ 8	5 ÷ 60	0.02	4	0,48
CGPM-12L	42	21	42	21	9.2	40	38	3 ÷ 8	5 ÷ 60	0.02	4	0,49
CPGM-12L-NC	50	25	28	14	9.2	40	38	4 ÷ 8	5 ÷ 60	0.02	4	0,50
CGPM-12L-NO	28	14	50	25	9.2	40	38	4 ÷ 8	5 ÷ 60	0.02	4	0,50

CGPM gripper, size 16 - dimensions



SERIES CGPM PARALLEL GRIPPERS WITH H-GUIDE

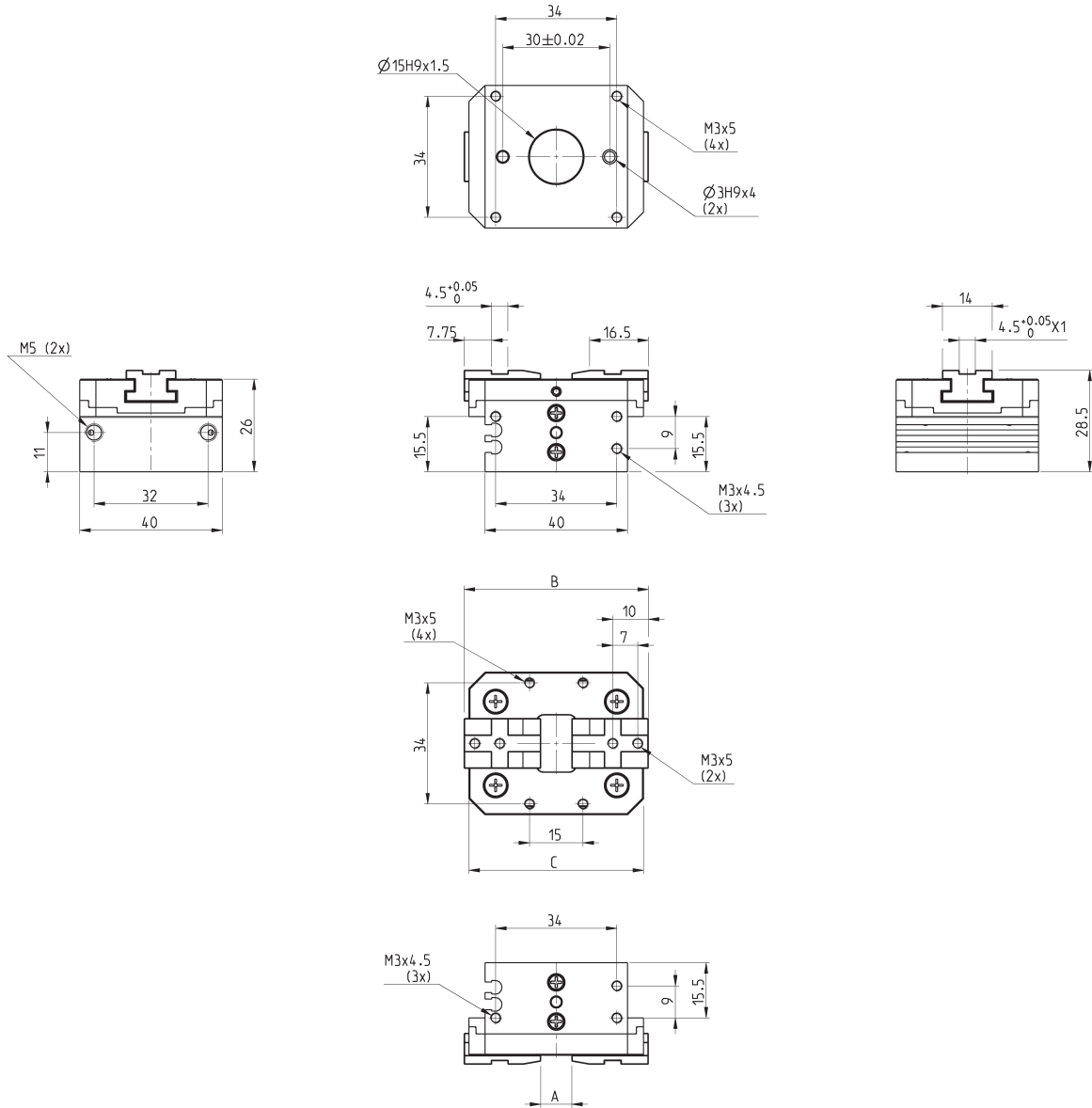

Mod.	Total closing grippin force at 6 bar (N)	Closing gripping force each jaw at 6 bar (N)	Total opening grippin force at 6 bar (N)	Opening gripping force each jaw at 6 bar (N)	Total stroke A (mm)	Open gripper B (mm)	C (mm)	Working Pressure (bar)	Working Temperature (°C)	Repeatability (mm)	Max use frequency (Hz)	Weight (Kg)
CGPM-16	124	62	124	62	8.7	51.7	49	2 ÷ 8	5 ÷ 60	0.02	4	0,120
CGPM-16-NC	144	72	88	44	8.7	51.7	49	4 ÷ 8	5 ÷ 60	0.02	4	0,121
CGPM-16-NO	88	44	144	72	8.7	51.7	49	4 ÷ 8	5 ÷ 60	0.02	4	0,121
CGPM-16L	70	35	70	35	14	57.4	55	2 ÷ 8	5 ÷ 60	0.02	4	0,124
CGPM-16L-NC	82	41	50	25	14	57.4	55	4 ÷ 8	5 ÷ 60	0.02	4	0,125
CGPM-16L-NO	50	25	82	41	14	57.4	55	4 ÷ 8	5 ÷ 60	0.02	4	0,125

CGPM gripper, size 25 - dimensions

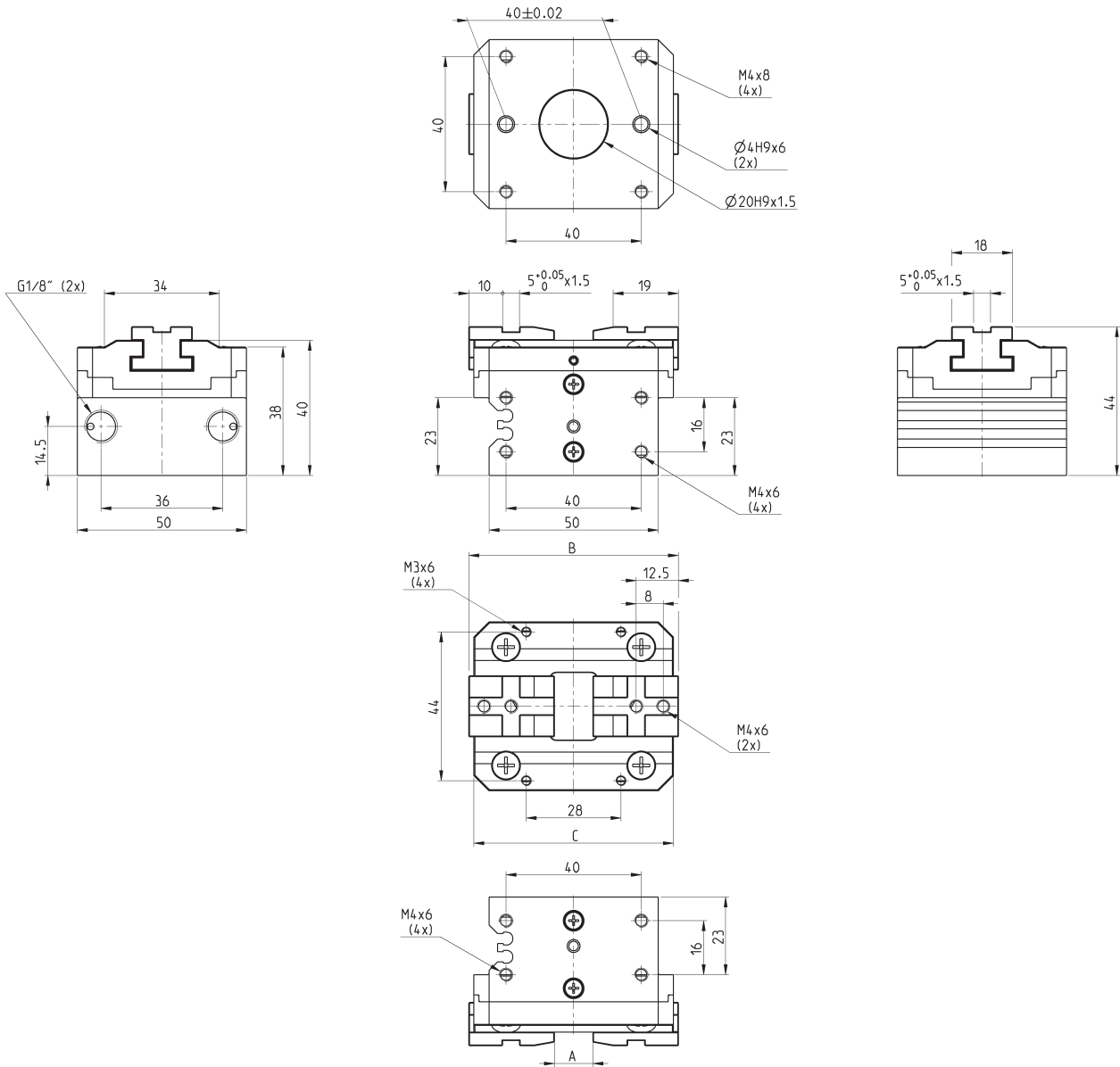

Mod.	Total closing grippin force at 6 bar (N)	Closing gripping force each jaw at 6 bar (N)	Total opening grippin force at 6 bar (N)	Opening gripping force each jaw at 6 bar (N)	Total stroke A (mm)	Open gripper B (mm)	C (mm)	Working Pressure (bar)	Working Temperature (°C)	Repeatability (mm)	Max use frequency (Hz)	Weight (Kg)
CGPM-25	300	150	300	150	11.4	62	59	2 ÷ 8	5 ÷ 60	0.02	3	0,274
CGPM-25-NC	354	177	210	105	11.4	62	59	4 ÷ 8	5 ÷ 60	0.02	3	0,278
CGPM-25-NO	210	105	354	177	11.4	62	59	4 ÷ 8	5 ÷ 60	0.02	3	0,278
CGPM-25L	168	84	168	84	19.4	70.8	69	2 ÷ 8	5 ÷ 60	0.02	3	0,283
CGPM-25L-NC	198	99	118	59	19.4	70.8	69	4 ÷ 8	5 ÷ 60	0.02	3	0,287
CGPM-25L-NO	118	59	198	99	19.4	70.8	69	4 ÷ 8	5 ÷ 60	0.02	3	0,287

CGPM gripper, size 35 - dimensions



SERIES CGPM PARALLEL GRIPPERS WITH H-GUIDE

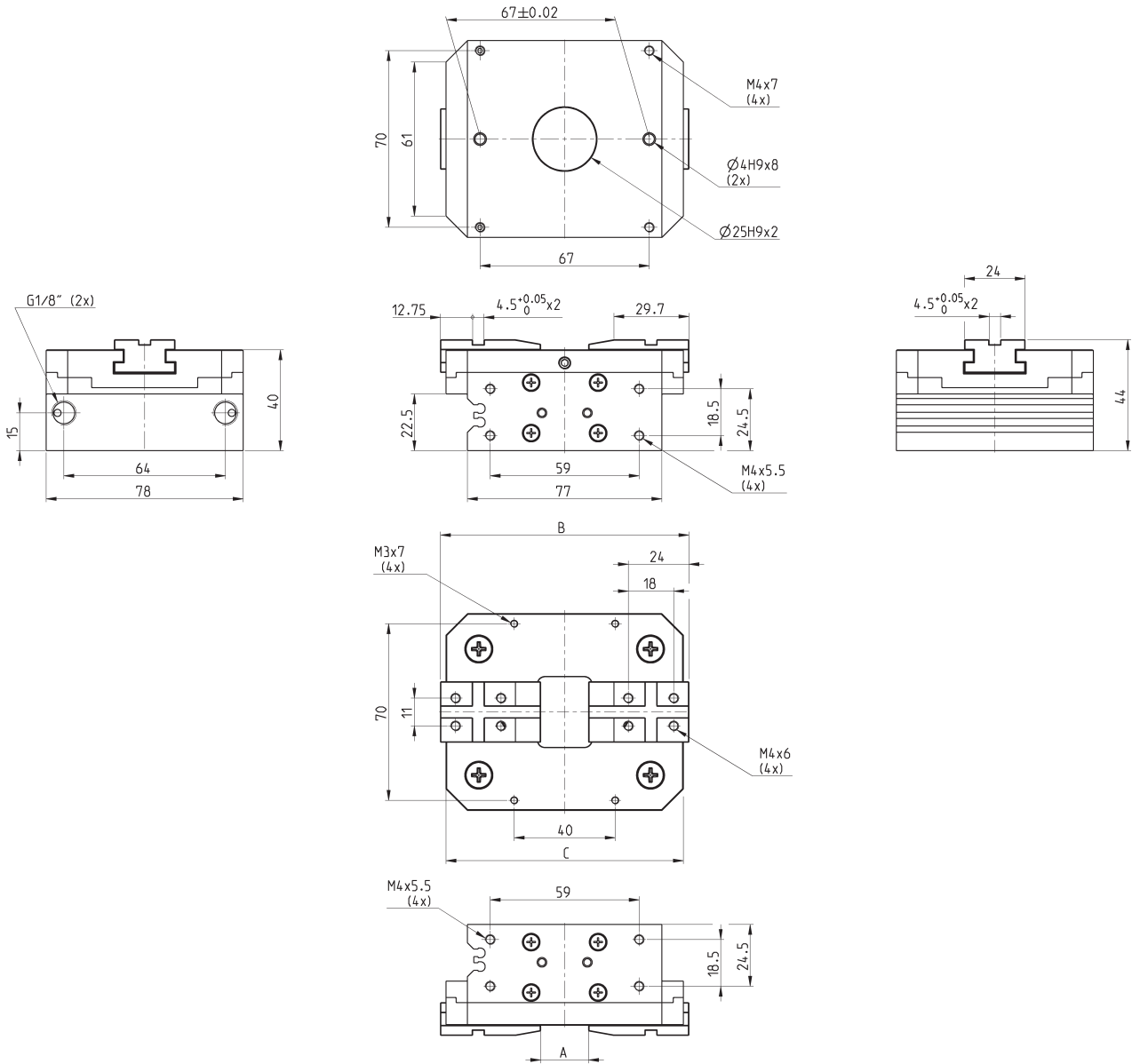

Mod.	Total closing grippin force at 6 bar (N)	Closing gripping force each jaw at 6 bar (N)	Total opening grippin force at 6 bar (N)	Opening gripping force each jaw at 6 bar (N)	Total stroke A (mm)	Open gripper B (mm)	C (mm)	Working Pressure (bar)	Working Temperature (°C)	Repeatability (mm)	Max use frequency (Hz)	Weight (Kg)
CGPM-35	638	319	638	319	19	98.4	94	2 ÷ 8	5 ÷ 60	0.02	3	0,658
CGPM-35-NC	712	356	450	225	19	98.4	94	4 ÷ 8	5 ÷ 60	0.02	3	0,668
CGPM-35-NO	450	225	712	356	19	98.4	94	4 ÷ 8	5 ÷ 60	0.02	3	0,668
CGPM-35L	350	175	350	175	32	112.1	108	2 ÷ 8	5 ÷ 60	0.02	3	0,676
CGPM-35L-NC	402	201	254	127	32	112.1	108	4 ÷ 8	5 ÷ 60	0.02	3	0,686
CGPM-35L-NO	254	127	402	201	32	112.1	108	4 ÷ 8	5 ÷ 60	0.02	3	0,686

CGPM gripper, size 45 - dimensions

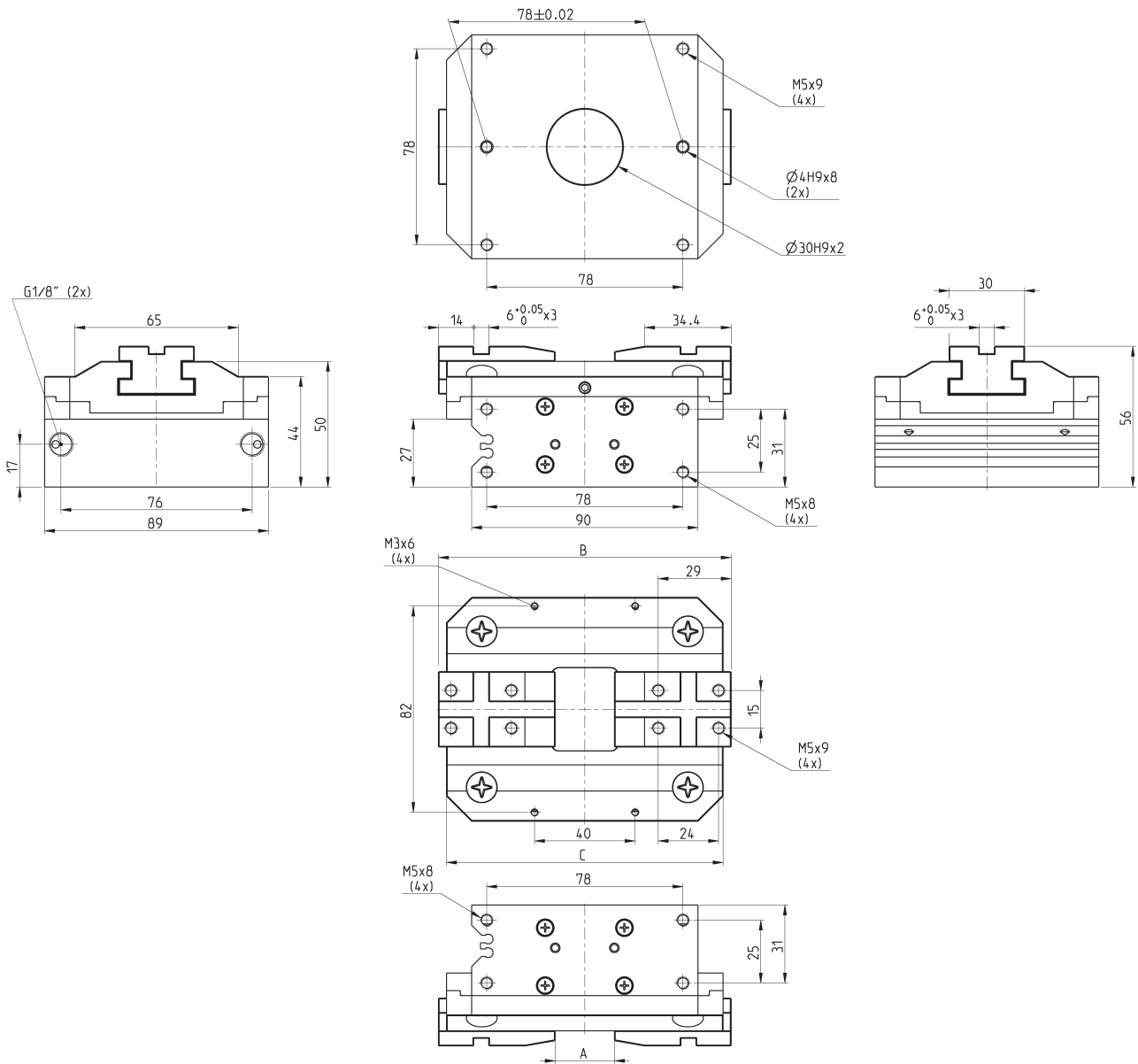

Mod.	Total closing gripping force at 6 bar (N)	Closing gripping force each jaw at 6 bar (N)	Total opening gripping force at 6 bar (N)	Opening gripping force each jaw at 6 bar (N)	Total stroke A (mm)	Open gripper B (mm)	C (mm)	Working Pressure (bar)	Working Temperature (°C)	Repeatability (mm)	Max use frequency (Hz)	Weight (Kg)
CGPM-45	906	453	906	453	23.6	116.4	110	2 ÷ 8	5 ÷ 60	0.02	3	1,094
CGPM-45-NC	1082	541	600	300	23.6	116.4	110	4 ÷ 8	5 ÷ 60	0.02	3	1,112
CGPM-45-NO	600	300	1082	541	23.6	116.4	110	4 ÷ 8	5 ÷ 60	0.02	3	1,112
CGPM-45L	510	255	510	255	41	133.6	128	2 ÷ 8	5 ÷ 60	0.02	3	1,126
CGPM-45L-NC	610	305	338	169	41	133.6	128	4 ÷ 8	5 ÷ 60	0.02	3	1,144
CGPM-45L-NO	338	169	610	305	41	133.6	128	4 ÷ 8	5 ÷ 60	0.02	3	1,144

GRIPPING FORCE (F) PER SINGLE JAW

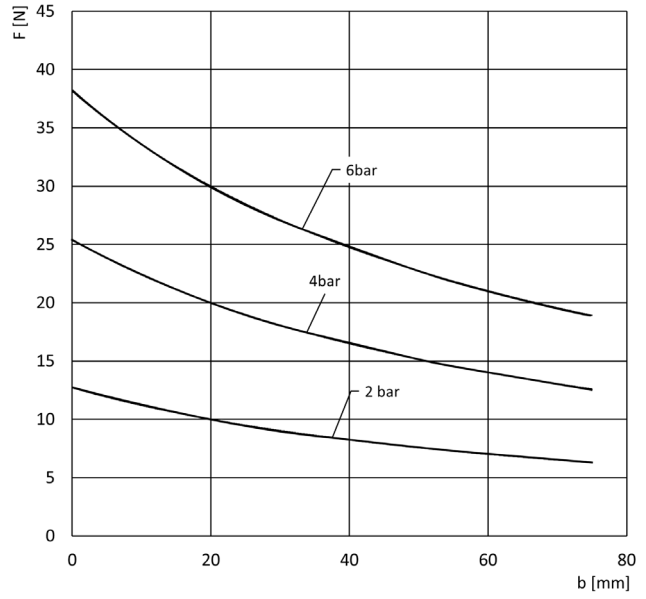
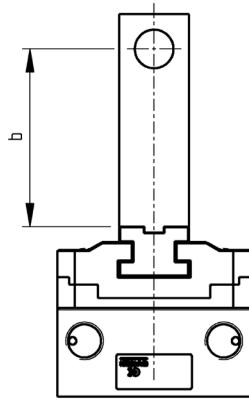

The total gripping force has to be calculated as follows:
Total F = F x 2

CGPM-12

b = Gripping point
F = Gripping force

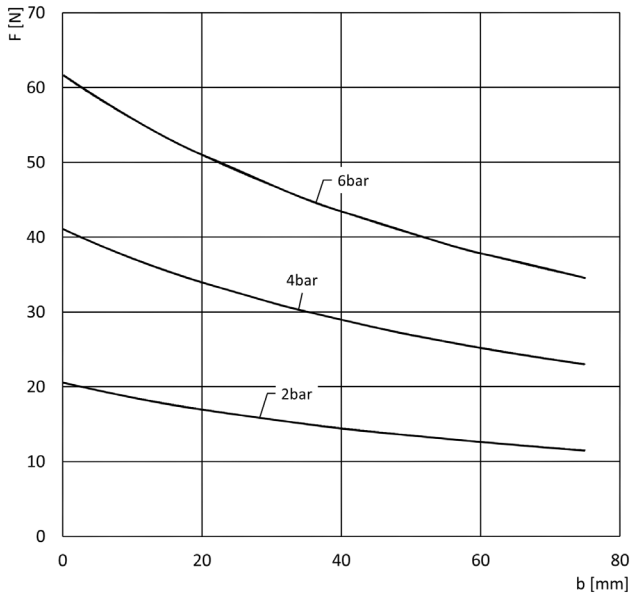

CGPM-16

b = Gripping point
F = Gripping force

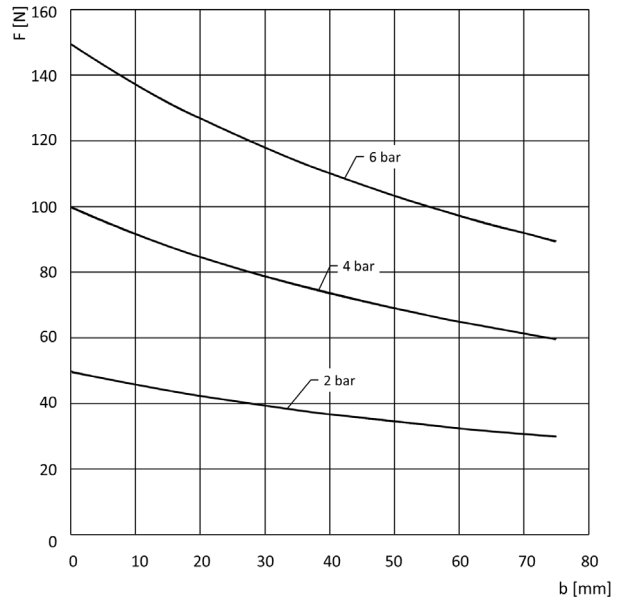

CGPM-25

b = Gripping point
F = Gripping force

GRIPPING FORCE (F) PER SINGLE JAW

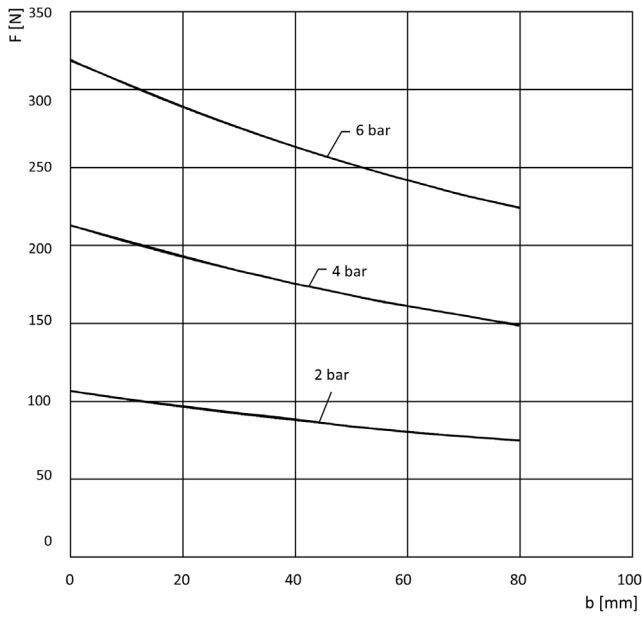

CGPM-35

b = Gripping point
F = Gripping force

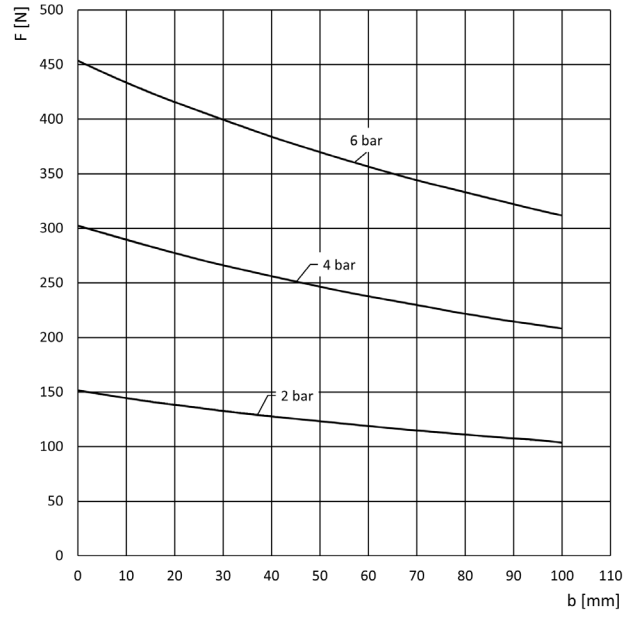

CGPM-45

b = Gripping point
F = Gripping force

SERIES CGPM PARALLEL GRIPPERS WITH H-GUIDE

GRIPPER'S USE AREA

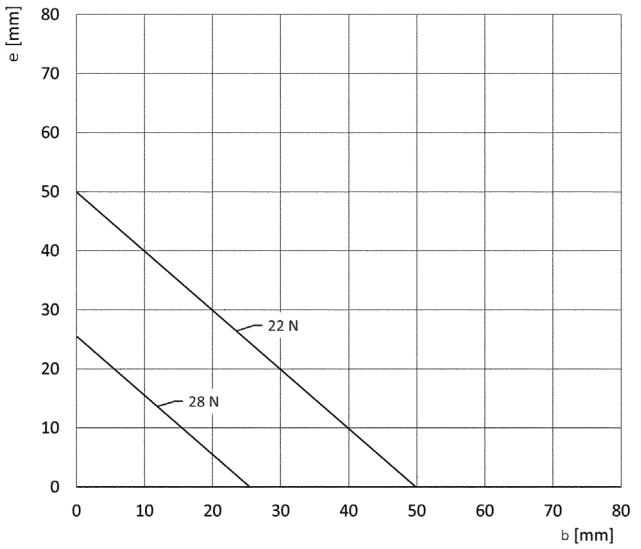
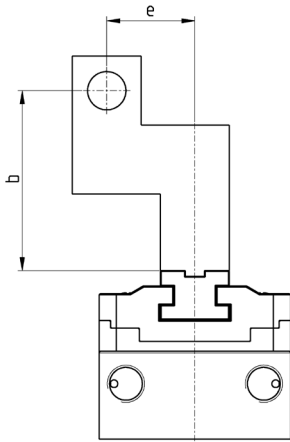

The total gripping force has to be calculated as follows:
Total F = F x 2

Gripper's use area according to the gripping point (b) and the arm (e)

CGPM-12

b = Gripping point
e = Arm

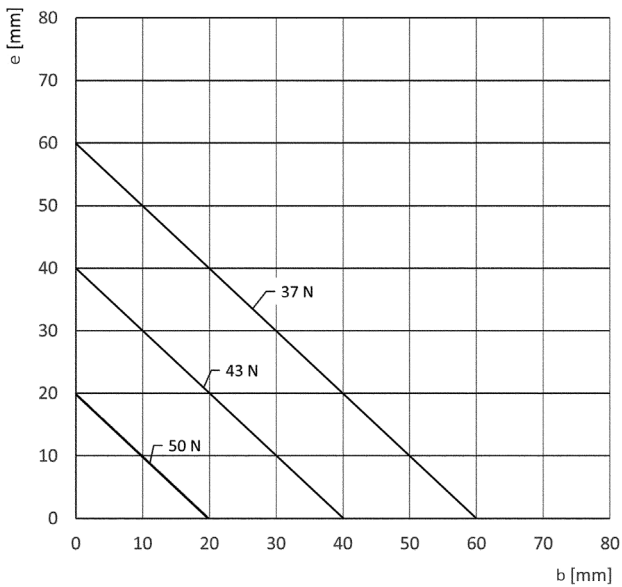

CGPM-16

b = Gripping point
e = Arm

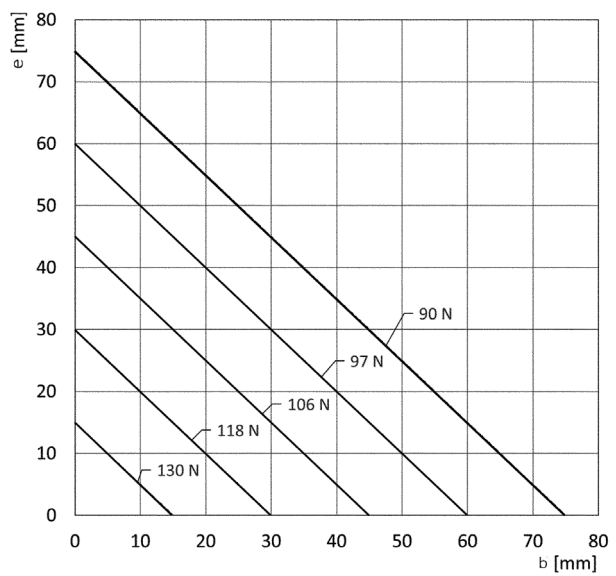

CGPM-25

b = Gripping point
e = Arm

GRIPPING FORCE (F) PER SINGLE JAW

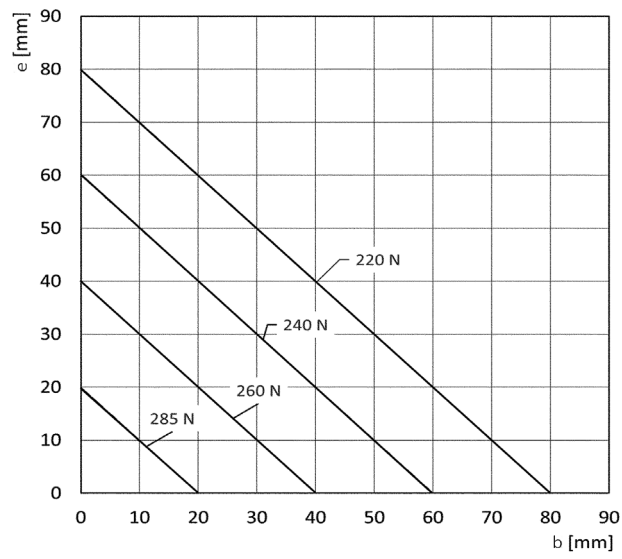

CGPM-35

b = Gripping point
e = Arm

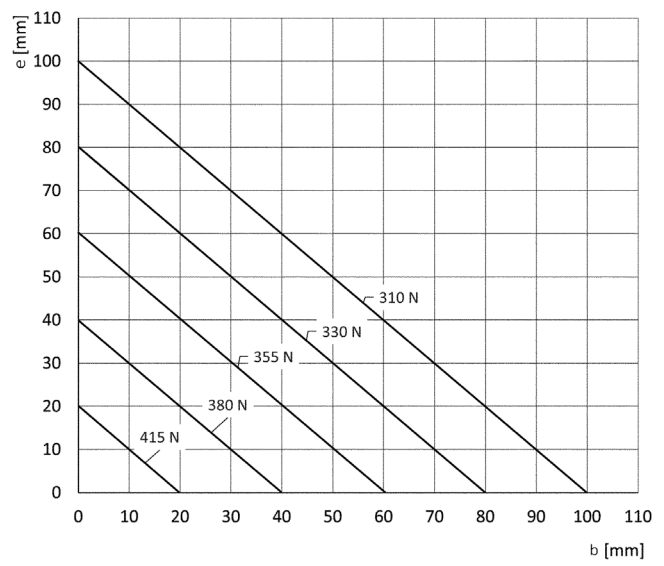

CGPM-45

b = Gripping point
e = Arm

GRIPPING FORCE (F) PER SINGLE JAW – L VERSION (Long Stroke)

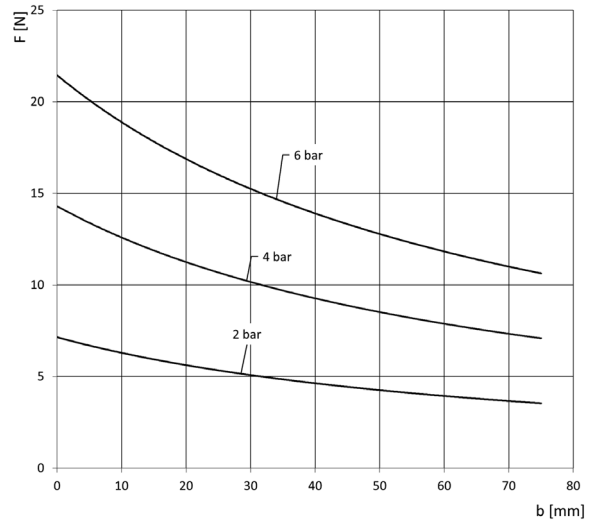
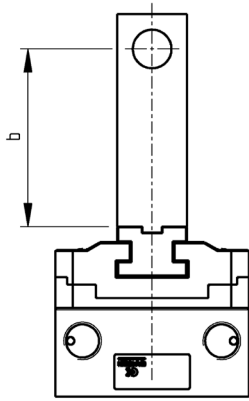

The total gripping force has to be calculated as follows:
Total F = F x 2

CGPM-12L

b = Gripping point
F = Gripping force

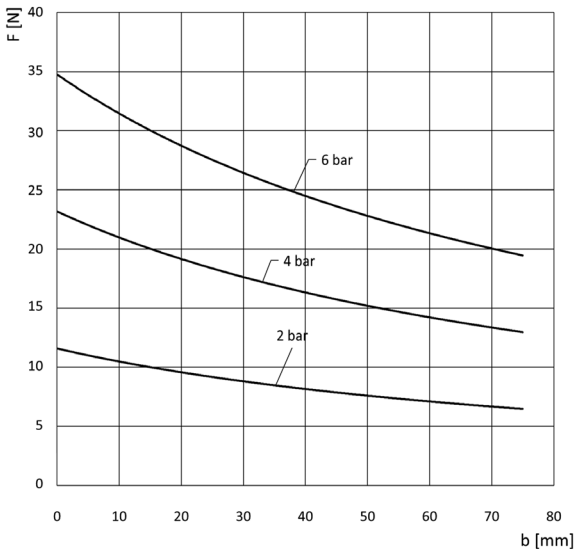

CGPM-16L

b = Gripping point
F = Gripping force

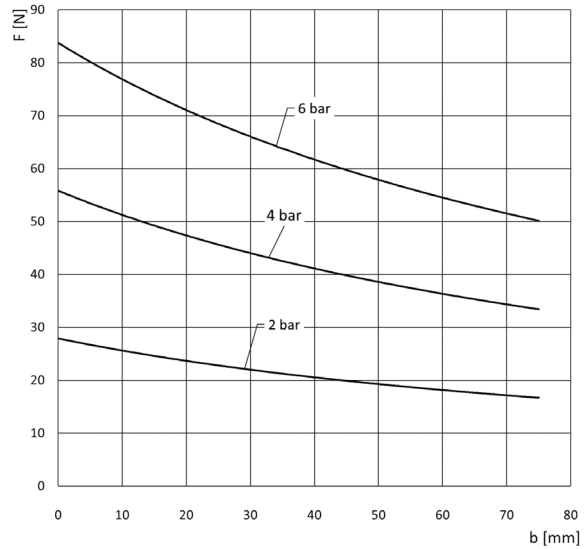

CGPM-25L

b = Gripping point
F = Gripping force

GRIPPING FORCE (F) PER SINGLE JAW

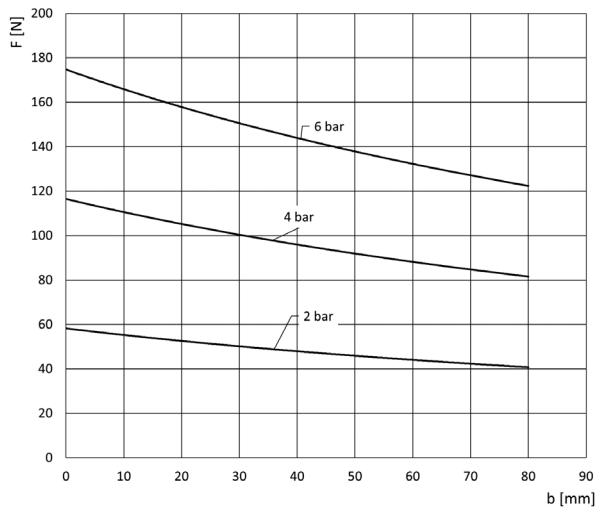

CGPM-35L

b = Gripping point
F = Gripping force

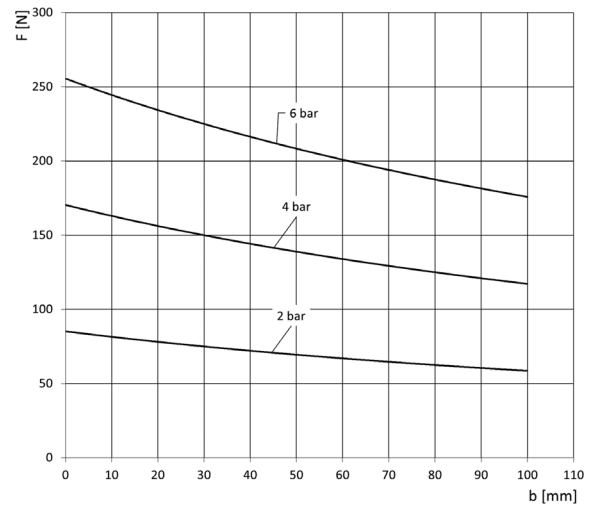

CGPM-45L

b = Gripping point
F = Gripping force

Examples of mounting

SERIES CGPM PARALLEL GRIPPERS WITH H-GUIDE

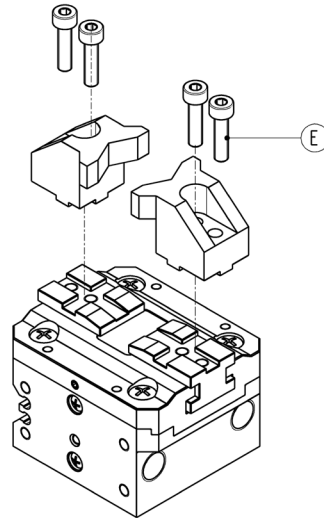
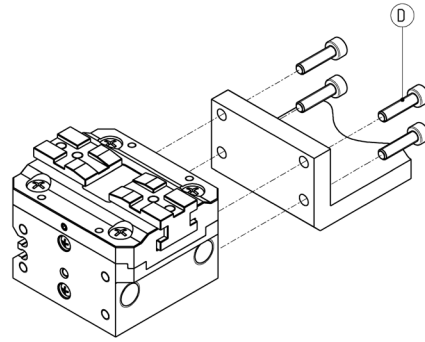
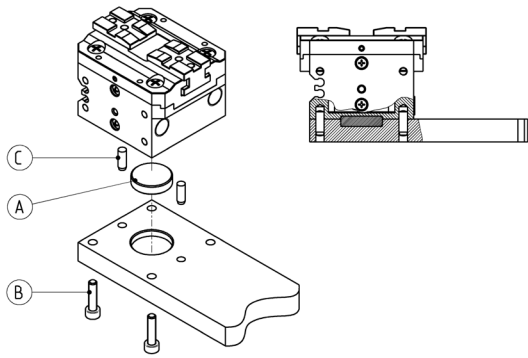

Mod.	A	B	C	D	E
CGPM-12/12L	Ø10	M3	Ø2	M3	M3
CGPM-16/16L	Ø15	M3	Ø3	M3	M3
CGPM-25/25L	Ø20	M4	Ø4	M4	M4
CGPM-35/35L	Ø25	M4	Ø4	M4	M4
CGPM-45/45L	Ø30	M5	Ø4	M5	M5

Example of use of the pressurization/lubrication hole

Example of use of the lubrication (greasing) or pressurization hole of the zone with moving items

NOTE 1: grease the sliding zones using Molykote DX grease.

NOTE 2: supply a pressure of max. 2 bar in order to avoid the sudden ejection of grease.

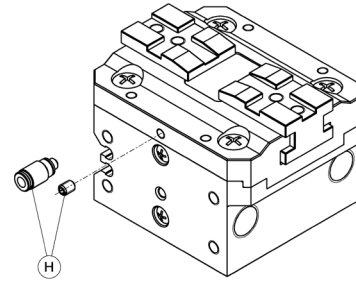

Mod.	H
CGPM-12	M3
CGPM-16	M3
CGPM-25	M3
CGPM-35	M5
CGPM-45	M5

Example of mounting: sensors

Series CSD

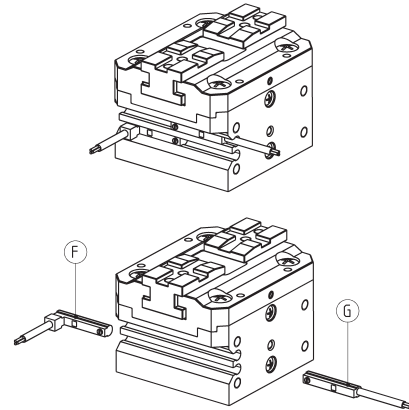

Mod.
F = CSD-H-334 CSD-H-364
G = CSD-D-334 CSD-D-364

Air supply ports

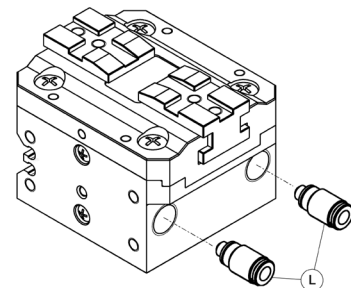

Mod.	L
CGPM-10	M3
CGPM-16	M5
CGPM-25	G 1/8
CGPM-35	G 1/8
CGPM-45	G 1/8

Magnetic proximity switches, 3-wire cable, D-slot

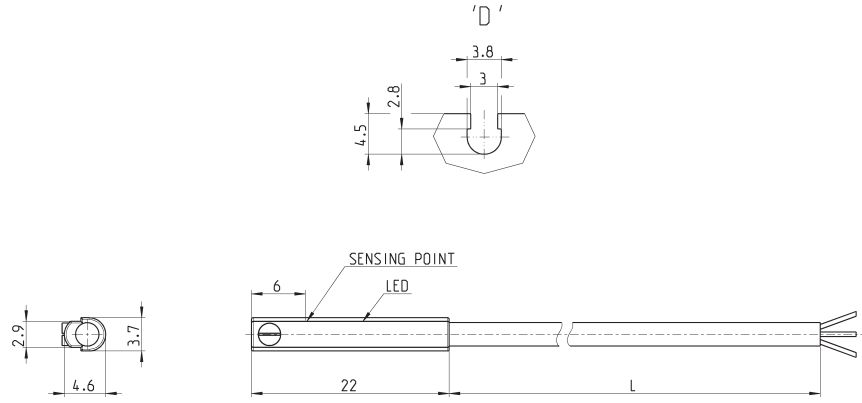

Mod.	Operation	Connections	Voltage	Output	Max. current	Max Load	Protection	L = length cable
CSD-D-334	Magneto-resistive	3 wires	10 ÷ 27 V DC	PNP	200 mA	6W	Against polarity reversing and overvoltage	2 m
CSD-D-334-5	Magneto-resistive	3 wires	10 ÷ 27 V DC	PNP	200 mA	6W	Against polarity reversing and overvoltage	5 m

Magnetic proximity switches, 3-wire cable, D-slot with 90° cable

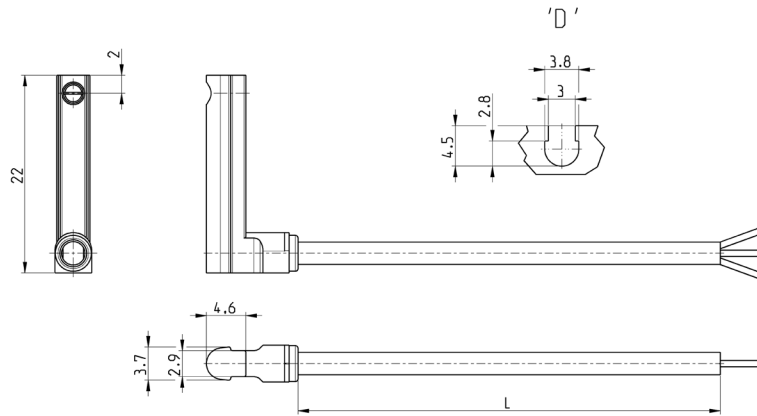

Mod.	Operation	Connections	Voltage	Output	Max. current	Max Load	Protection	L = length cable
CSD-H-334	Magneto-resistive	3 wires	10 ÷ 27 V DC	PNP	200 mA	6 W	Against polarity reversing and overvoltage	2 m
CSD-H-334-5	Magneto-resistive	3 wires	10 ÷ 27 V DC	PNP	200 mA	6 W	Against polarity reversing and overvoltage	5 m

Magnetic proximity switches, male M8 3-pin conn., D-slot, straight



Cable length: 0.3 m

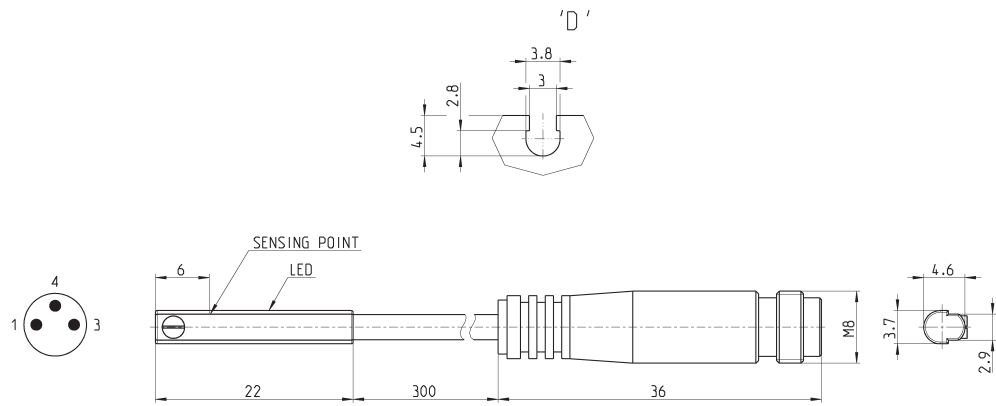

Mod.	Operation	Connection	Voltage	Output	Max current	Max load	Protection
CSD-D-364	Magnetostrictive	3 wires with M8 connector	10 ÷ 27 V DC	PNP	200 mA	6 W	Against polarity reversing and overvoltage

Magnetic proximity switches, male M8 3-pin conn., D-slot, 90°



Cable length: 0.3 m

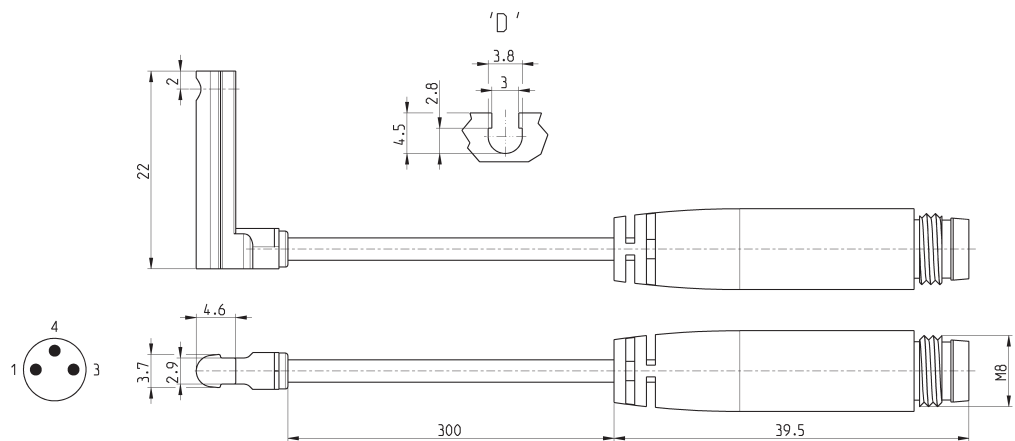

Mod.	Operation	Connection	Voltage	Output	Max current	Max load	Protection
CSD-H-364	Magnetostrictive	3 wires with M8 connector	10 ÷ 27 V DC	PNP	200 mA	6 W	Against polarity reversing and overvoltage