

# Series TMCU, TMVU, TMCO flow control valves

Unidirectional and bidirectional banjo flow controllers with nominal diameter 2 - 3,8 - 5,8 - 8 mm  
Ports: G1/8, G1/4, G3/8, G1/2

SERIES TMCU, TMVU, TMCO VALVES



Series TMCU, TMVU, TMCO unidirectional and bidirectional flow controllers have been revised in order to decrease their dimensions and improve their flow rate characteristics. Their construction allows for easy assembly to cylinders and valves and allows the regulation adjustment to be precise and gradual.

## GENERAL DATA

<b>Construction</b>	needle - type
<b>Valve group</b>	unidirectional and bidirectional controller
<b>Materials</b>	brass - technopolymer - NBR
<b>Mounting</b>	by male threaded
<b>Threaded ports</b>	G1/8 - G1/4 - G3/8 - G1/2
<b>Installation</b>	in any position
<b>Operating temperature</b>	0°C ÷ 60°C (with dry air -20°C)
<b>Operating pressure</b>	0,5 ÷ 10 bar
<b>Nominal pressure</b>	6 bar
<b>Nominal flow</b>	see graph
<b>Nominal dia.</b>	Tube 4 Ø2 - Tube 6 Ø3,8 - Tube 8 Ø5,8 - Tube 10 and 12 Ø8
<b>Fluid</b>	filtered air If lubricated air is used, it is recommended to use ISOVG 32 oil. Once applied the lubrication should never be interrupted.

## CODING EXAMPLE

<b>TM</b>	<b>CU</b>		<b>9</b>	<b>74</b>	<b>-</b>	<b>1/8</b>	<b>-</b>	<b>6</b>
-----------	-----------	--	----------	-----------	----------	------------	----------	----------

<b>TM</b>	ACTUATION: TM = manual																				
<b>CU</b>	ASSEMBLY: CU = on cylinders unidirectional VU = on valves unidirectional CO = bidirectional																				
<b>9</b>	VERSIONS: 9 = manual needle																				
<b>74</b>	REGULATION: <table border="1"> <thead> <tr> <th></th> <th>step</th> <th>-</th> <th>∅ tube</th> </tr> </thead> <tbody> <tr> <td>72 =</td> <td>2</td> <td></td> <td>4</td> </tr> <tr> <td>74 =</td> <td>3.8</td> <td></td> <td>6</td> </tr> <tr> <td>76 =</td> <td>5.8</td> <td></td> <td>8</td> </tr> <tr> <td>78 =</td> <td>8</td> <td></td> <td>10</td> </tr> </tbody> </table>		step	-	∅ tube	72 =	2		4	74 =	3.8		6	76 =	5.8		8	78 =	8		10
	step	-	∅ tube																		
72 =	2		4																		
74 =	3.8		6																		
76 =	5.8		8																		
78 =	8		10																		
<b>1/8</b>	PORTS: 1/8 1/4 3/8 1/2																				
<b>6</b>	∅ TUBE: 4 6 8 10																				

To ensure the right choice of unidirectional flow controller, proceed as follows: calculate the quantity of air in NI/min (see cylinder Table); determine the stroke time of the cylinder; refer to graph to see which controller is the right type.

**UNIDIRECTIONAL AND BIDIRECTIONAL FLOW CONTROL REGULATORS**

SERIES TMCU, TMVU, TMCO VALVES

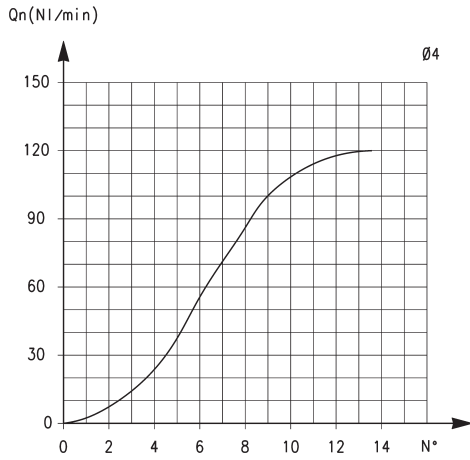

**TUBE Ø4**

Flow Qn (NL/min.) from 2 → 1 with controller OPEN: 400  
 Flow Qn (NL/min.) from 2 → 1 with controller CLOSED: 280  
 Qn is determined with a supply pressure of 6 bar and with ΔP = 1 bar at the outlet  
 N° = number of screw turns.

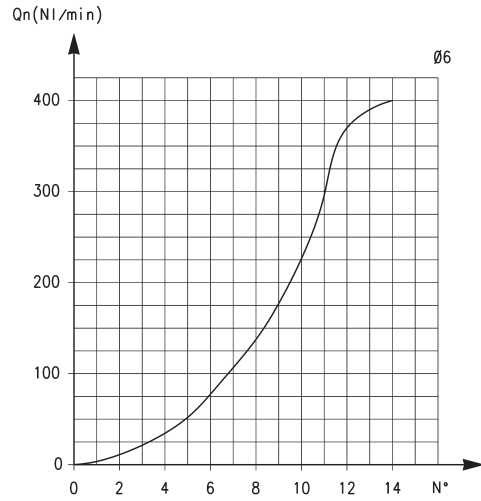

**TUBE Ø6**

Flow Qn (NL/min.) from 2 → 1 with controller OPEN: 550  
 Flow Qn (NL/min.) from 2 → 1 with controller CLOSED: 280  
 Qn is determined with a supply pressure of 6 bar and with ΔP = 1 bar at the outlet  
 N° = number of screw turns.

**UNIDIRECTIONAL AND BIDIRECTIONAL FLOW CONTROL REGULATORS**

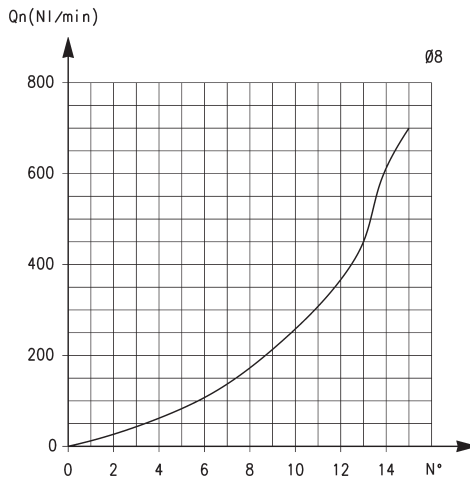

**TUBE Ø8**

Flow Qn (NL/min.) from 2 → 1 with controller OPEN: 890  
 Flow Qn (NL/min.) from 2 → 1 with controller CLOSED: 460  
 Qn is determined with a supply pressure of 6 bar and with ΔP = 1 bar at the outlet  
 N° = number of screw turns.

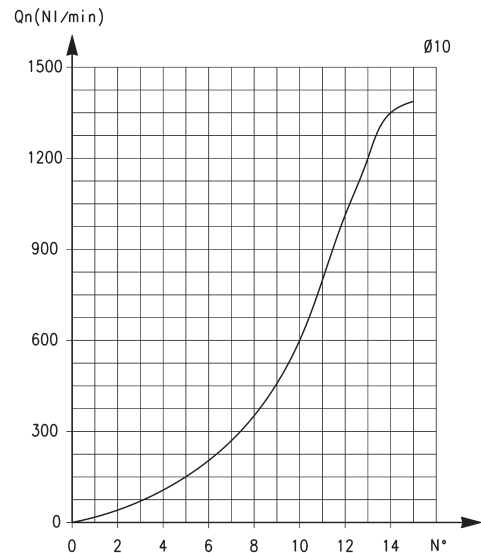

**TUBE Ø10**

Flow Qn (NL/min.) from 2 → 1 with controller OPEN: Ø 10-1200/Ø12-1250  
 Flow Qn (NL/min.) from 2 → 1 with controller CLOSED: Ø 10-600/Ø12-600  
 Qn is determined with a supply pressure of 6 bar and with ΔP = 1 bar at the outlet  
 N° = number of screw turns.

## Series TMCU valves



Unidirectional flow controller for mounting on single-acting or double-acting cylinders.  
Adjustment of setting by a hexagonal male key or a manually operated knurled screw.  
Ports: G1/8, G1/4, G3/8, G1/2

DIMENSIONS										
Mod.	A	B	F	H	L	M	S	SW	SW1	Z
TMCU 972-1/8-4	G1/8	4	11,5	5	43	21,5	16,5	16	1,5	50
TMCU 974-1/8-6	G1/8	6	11,5	5	43	21,5	16,5	16	1,5	50
TMCU 974-1/4-6	G1/4	6	11,5	6	44	21,5	16,5	17	1,5	51
TMCU 976-1/8-8	G1/8	8	13,5	5	47	25	17,5	19	2,5	54
TMCU 976-1/4-8	G1/4	8	13,5	6	48,5	25	18	19	2,5	55,5
TMCU 976-3/8-8	G3/8	8	13,5	7	49,5	25	18	20	2,5	56,5
TMCU 978-3/8-10	G3/8	10	16	7	51	29	17	25	2,5	59,5
TMCU 978-1/2-10	G1/2	10	16	8	52	29	17	25	2,5	60,5

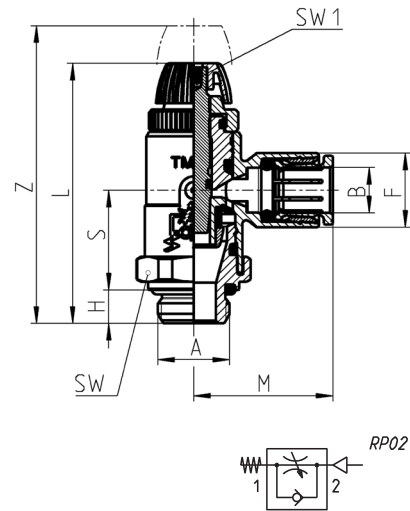

## Series TMVU valves



Unidirectional flow controller for mounting on valves.  
Adjustment of setting by a hexagonal male key or a manually operated knurled screw.  
Ports: G1/8, G1/4, G3/8, G1/2

DIMENSIONS										
Mod.	A	B	F	H	L	M	S	SW	SW1	Z
TMVU 972-1/8-4	G1/8	4	11,5	5	43	21,5	16,5	16	1,5	50
TMVU 974-1/8-6	G1/8	6	11,5	5	43	21,5	16,5	16	1,5	50
TMVU 974-1/4-6	G1/4	6	11,5	6	44	21,5	16,5	17	1,5	51
TMVU 976-1/8-8	G1/8	8	13,5	5	47	25	17,5	19	2,5	54
TMVU 976-1/4-8	G1/4	8	13,5	6	48,5	25	18	19	2,5	55,5
TMVU 976-3/8-8	G3/8	8	13,5	7	49,5	25	18	20	2,5	56,5
TMVU 978-3/8-10	G3/8	10	16	7	51	29	17	25	2,5	59,5
TMVU 978-1/2-10	G1/2	10	18	8	52	29	17	25	2,5	60,5

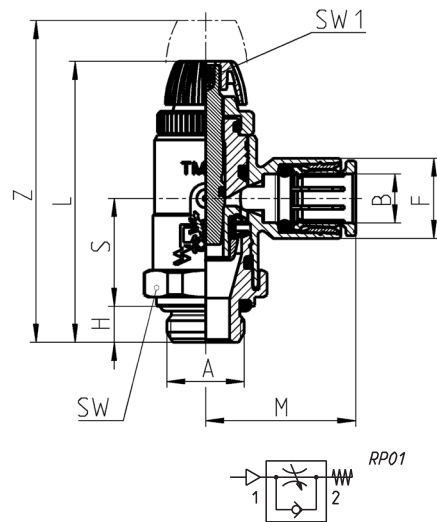

## Series TMCU valves



Bidirectional flow controller.  
Adjustment of setting by a hexagonal male key or a manually operated knurled screw.  
Ports: G1/8, G1/4, G3/8, G1/2

DIMENSIONS										
Mod.	A	B	F	H	L	M	S	SW	SW1	Z
TMCU 972-1/8-4	G1/8	4	11,5	5	43	21,5	16,5	16	1,5	50
TMCU 974-1/8-6	G1/8	6	11,5	5	43	21,5	16,5	16	1,5	50
TMCU 974-1/4-6	G1/4	6	11,5	6	44	21,5	16,5	17	1,5	51
TMCU 976-1/8-8	G1/8	8	13,5	5	47	25	17,5	19	2,5	54
TMCU 976-1/4-8	G1/4	8	13,5	6	48,5	25	18	19	2,5	55,5
TMCU 976-3/8-8	G3/8	8	13,5	7	49,5	25	18	20	2,5	56,5
TMCU 978-3/8-10	G3/8	10	16	7	51	29	17	25	2,5	59,5
TMCU 978-1/2-10	G1/2	10	16	8	52	29	17	25	2,5	60,5

