

Blocking valves Series VBO - VBU

Unidirectional valves (VBU) and bidirectional valves (VBO)
Ports G1/8, G1/4, G3/8 and G1/2
Tube diameter: 6, 8, 10, 12 mm



- » Series VBU: unidirectional valves with operating pressure from 0.3 to 10 bar
- » Series VBO: bidirectional valves with operating pressure from -0,9 to 10 bar
- » Series VBU: Threaded and push-in model
- » Direct mounting on cylinders or on distribution and fluid control blocks

These unidirectional and bidirectional blocking valves have been realised in order to enable mounting directly on cylinders. They can be used as high flow valves for blows, cleaning of pieces, filling of volumes. For these applications it is suggested to connect the supply to port 2 (having the male thread).

These valves can be mounted directly also on distribution and fluid control blocks.

GENERAL DATA

Construction	poppet type
Valve group	unidirectional and bidirectional blocking valve
Materials	Brass - NBR seals - stainless steel springs - PTFE
Mounting	by male thread
Inlet ports	G1/8 - G1/4 - G3/8 - G1/2
Outlet ports	Tube Ø6, Ø8, Ø10, Ø12 mm
Position	in any position
Operating temperature	0°C ÷ 80°C (with dry air -20°C)
Operating pressure	VBU: 0,3 ÷ 10 bar, VBO: -0,9 ÷ 10 bar
Nominal pressure	6 bar
Nominal flow	see graph
Nominal diam.	G1/8 Ø 5,5 mm - G1/4 Ø 8 mm - G3/8 Ø 11 mm - G1/2 Ø 15 mm
Fluid	filtered air, without lubrication. If lubricated air is used, it is recommended to use oil ISO VG32. Once applied, the lubrication should never be interrupted.

CODING EXAMPLE THREADED VERSION

VB	0	1/8
-----------	----------	------------

VB	SERIES: VB
0	VERSIONS: U = unidirectional O = bidirectional
1/8	INLETS/OUTLETS PORTS: G1/8 G1/4 G3/8 G1/2

CODING EXAMPLE PUSH-IN VERSION

VB	U	6	U	1/8
-----------	----------	----------	----------	------------

VB	SERIES: VB
U	VERSIONS: U = unidirectional
6	OUTLET PORTS 6 mm 8 mm 10 mm 12 mm
1/8	INLET PORTS: G1/8 G1/4 G3/8 G1/2

DIAGRAM OF THE PILOT PRESSURE

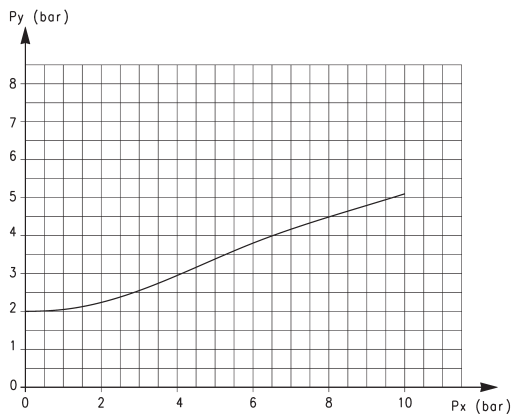

This diagram shows the relation between working pressure (Px) and pilot pressure required in order to operate the valve (Py). The opening pressure of the unidirectional valve is 0,3 bar.

FLOW DIAGRAMS OF UNIDIRECTIONAL AND BIDIRECTIONAL VALVES

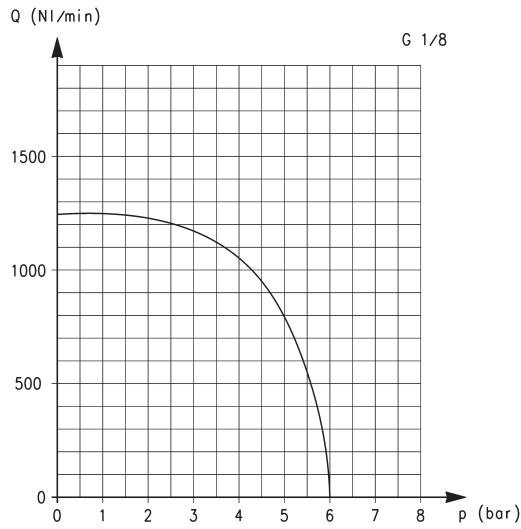

Diagram for valves VBU and VBO with G1/8 ports.

Q is the flow measured in NL/min and determined with an inlet pressure of 6 bar.

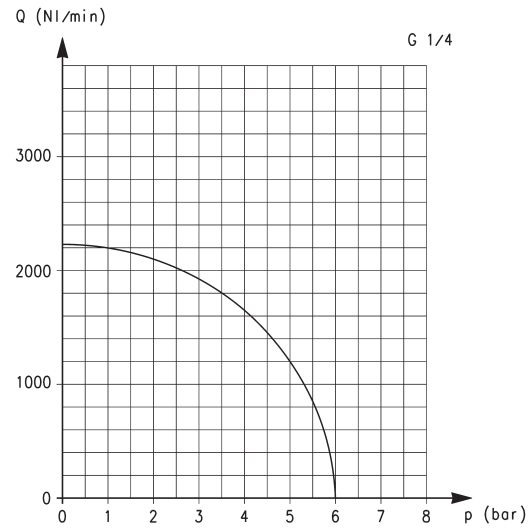

Diagram for valves VBU and VBO with G1/4 ports.

Q is the flow measured in NL/min and determined with an inlet pressure of 6 bar.

FLOW DIAGRAMS OF UNIDIRECTIONAL AND BIDIRECTIONAL VALVES

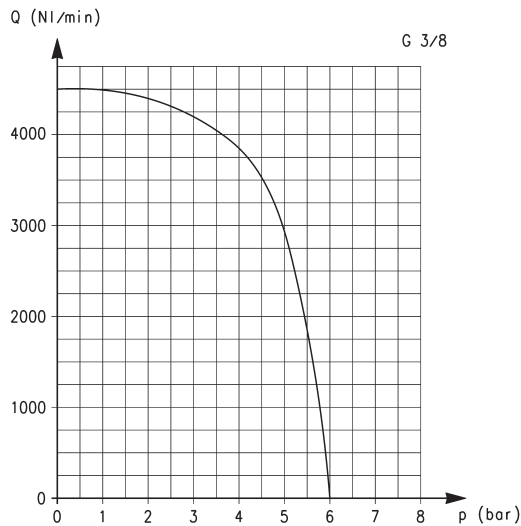

Diagram for valves VBU and VBO with G3/8 ports.

Q is the flow measured in NL/min and determined with an inlet pressure of 6 bar.

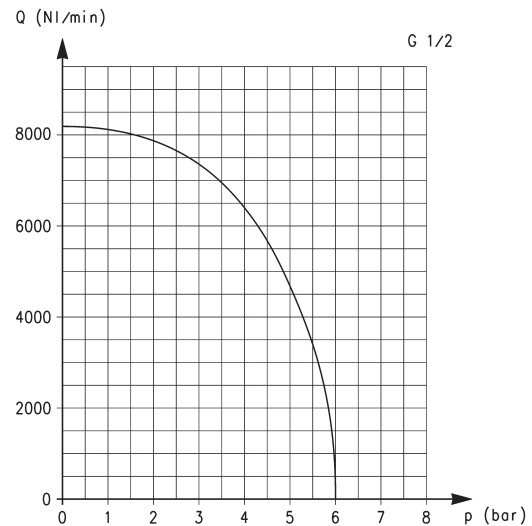

Diagram for valves VBU and VBO with G1/2 ports.

Q is the flow measured in NL/min and determined with an inlet pressure of 6 bar.

APPLICATION SCHEMES

VBU = UNIDIRECTIONAL blocking valve
VBO = BIDIRECTIONAL blocking valve

SERIES VBO AND VBU BLOCKING VALVES

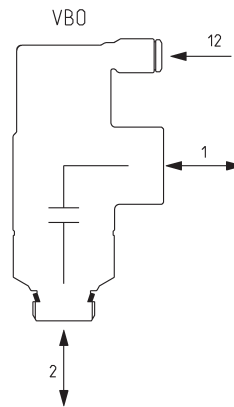
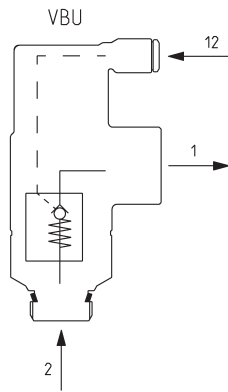
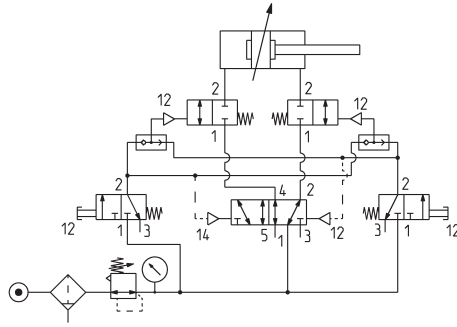
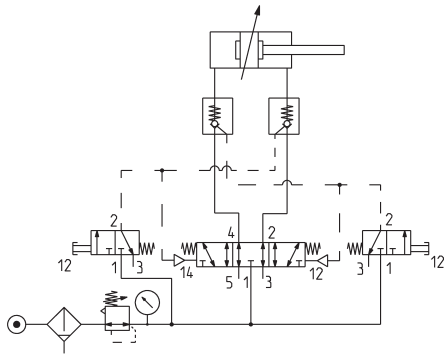
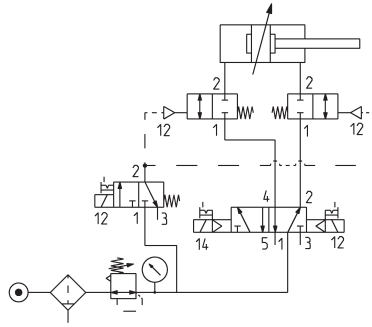
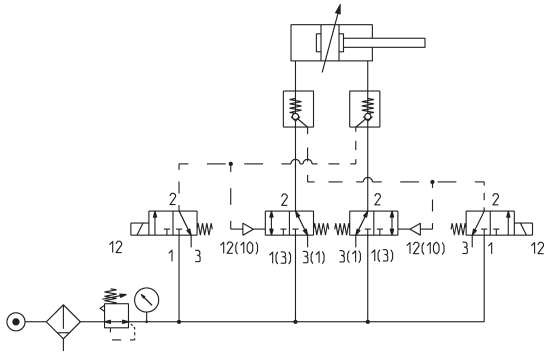

Bidirectional blocking valve

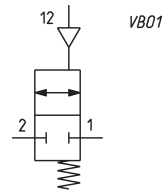
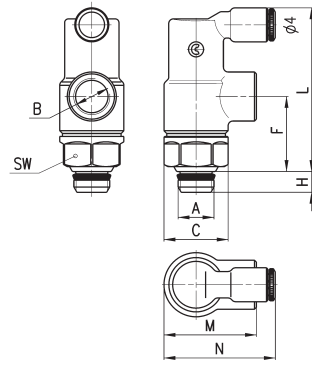

DIMENSIONS									
Mod.	A	B	C	F	H	L	M	N	SW
VBO 1/8	1/8	1/8	16,9	20	5,5	43	24,5	30	15
VBO 1/4	1/4	1/4	20,5	25	7	50	32,2	33,5	19
VBO 3/8	3/8	3/8	26,8	33	8	67	40	39,5	24
VBO 1/2	1/2	1/2	30	45,5	9	85,7	52	48	27

Unidirectional blocking valve

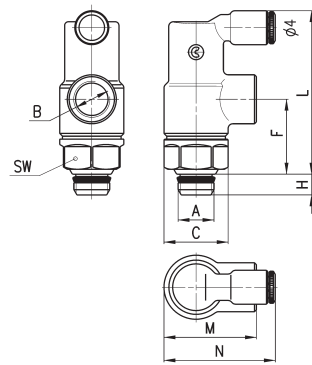

DIMENSIONS									
Mod.	A	B	C	F	H	L	M	N	SW
VBU 1/8	1/8	1/8	16,9	20	5,5	43	24,5	30	15
VBU 1/4	1/4	1/4	20,5	25	7	50	32,2	33,5	19
VBU 3/8	3/8	3/8	26,8	33	8	67	40	39,5	24
VBU 1/2	1/2	1/2	30	45,5	9	85,7	52	48	27

Unidirectional blocking valve

New

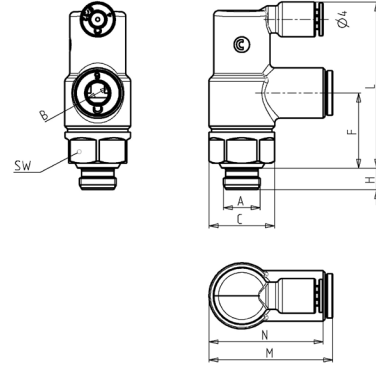

DIMENSIONS										
Mod.	A	B	C	F	H	L	M	N	SW	
VBU 6 1/8	G1/8	6	16,9	20	5,5	43	32	30	15	
VBU 6 1/4	G1/4	6	20,5	25	7	50	36	33,5	19	
VBU 8 1/4	G1/4	8	20,5	25	7	50	37,5	33,5	19	
VBU 8 3/8	G3/8	8	26,8	33	8	67	43,5	39,5	24	
VBU 10 3/8	G3/8	10	26,8	33	8	67	46,5	39,5	24	
VBU 12 1/2	G1/2	12	30	45,5	9	85,5	54,5	48	27	

SERIES VBO AND VBU BLOCKING VALVES