

Series VBO - VBU blocking valves

Unidirectional valves (VBU) and bidirectional valves (VBO)
Ports G1/8, G1/4, G3/8 and G1/2

SERIES VBO AND VBU BLOCKING VALVES



- » Series VBU: unidirectional valves with operating pressure from 0.3 to 10 bar
- » Series VBO: bidirectional valves with operating pressure from 0 to 10 bar
- » Direct mounting on cylinders or on distribution and fluid control blocks

These unidirectional and bidirectional blocking valves have been realised in order to enable mounting directly on cylinders. They can be used as high flow valves for blows, cleaning of pieces, filling of volumes. For these applications it is suggested to connect the supply to port 2 (having the male thread).

These valves can be mounted directly also on distribution and fluid control blocks.

GENERAL DATA

| | |
|-----------------------|---|
| Construction | poppet type |
| Valve group | unidirectional and bidirectional blocking valve |
| Materials | Brass - NBR seals - stainless steel springs - PTFE |
| Mounting | by male thread |
| Ports | G1/8 - G1/4 - G3/8 - G1/2 |
| Position | in any position |
| Operating temperature | 0°C ÷ 80°C (with dry air -20°C) |
| Operating pressure | VBU: 0,3 ÷ 10 bar, VBO: 0 ÷ 10 bar |
| Nominal pressure | 6 bar |
| Nominal flow | see graph |
| Nominal diam. | G1/8 ø 5,5 mm - G1/4 ø 8 mm - G3/8 ø 11 mm - G1/2 ø 15 mm |
| Fluid | filtered air, without lubrication. If lubricated air is used, it is recommended to use oil ISO VG32. Once applied, the lubrication should never be interrupted. |

CODING EXAMPLE

| | | |
|------------|--|------------|
| VB | U | 1/8 |
| VB | SERIES: VB | |
| U | VERSIONS: U = unidirectional O = bidirectional | |
| 1/8 | PORTS: G1/8 G1/4 G3/8 G1/2 | |

DIAGRAM OF THE PILOT PRESSURE

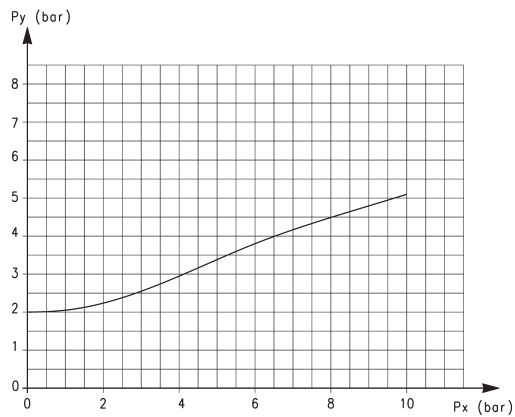

This diagram shows the relation between working pressure (Px) and pilot pressure required in order to operate the valve (Py). The opening pressure of the unidirectional valve is 0,3 bar.

FLOW DIAGRAMS OF UNIDIRECTIONAL AND BIDIRECTIONAL VALVES

SERIES VBO AND VBU BLOCKING VALVES

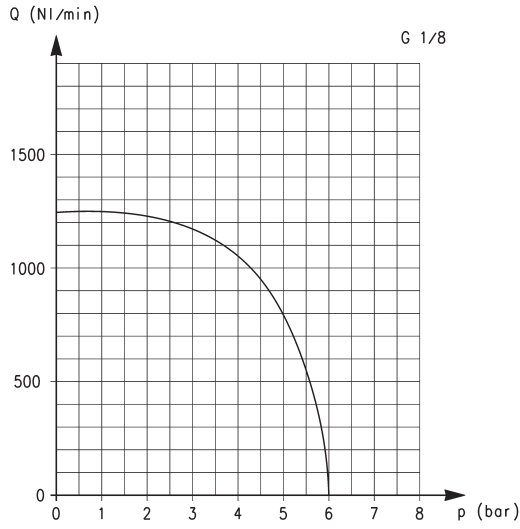

Diagram for valves VBU and VBO with G1/8 ports.

Q is the flow measured in NI/min and determined with an inlet pressure of 6 bar.

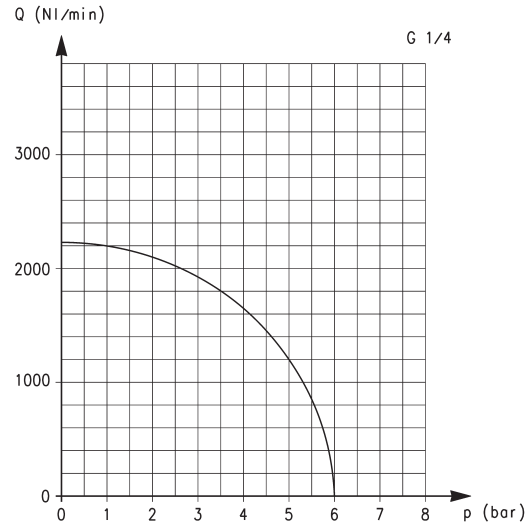

Diagram for valves VBU and VBO with G1/4 ports.

Q is the flow measured in NI/min and determined with an inlet pressure of 6 bar.

FLOW DIAGRAMS OF UNIDIRECTIONAL AND BIDIRECTIONAL VALVES

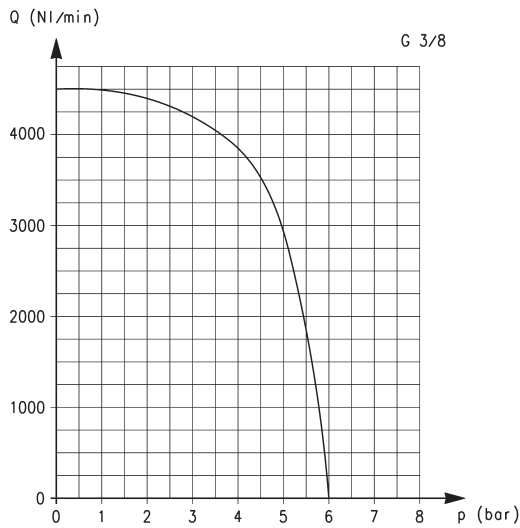

Diagram for valves VBU and VBO with G3/8 ports.

Q is the flow measured in NI/min and determined with an inlet pressure of 6 bar.

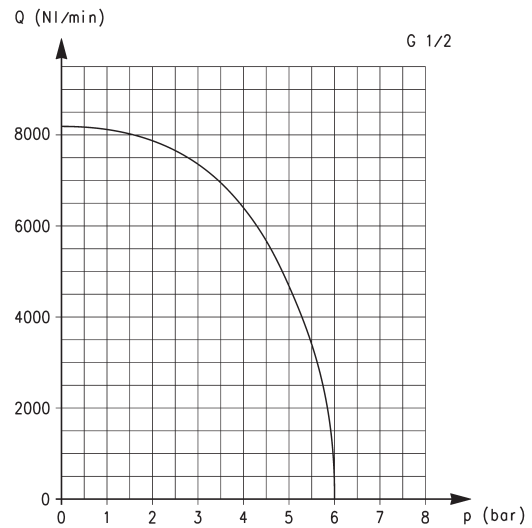
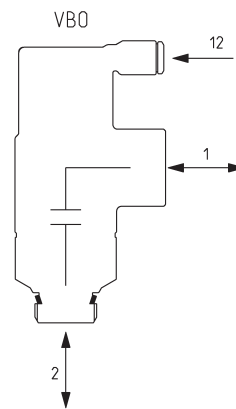
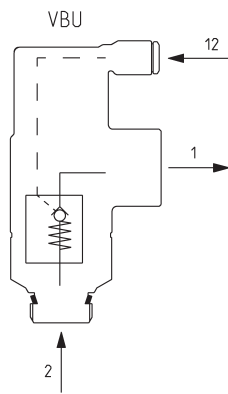
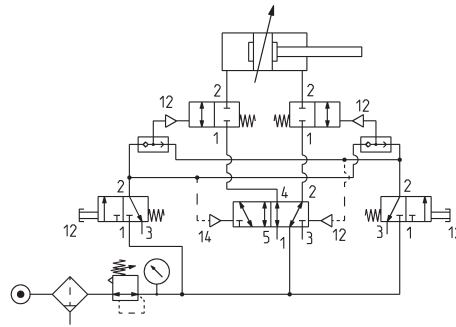
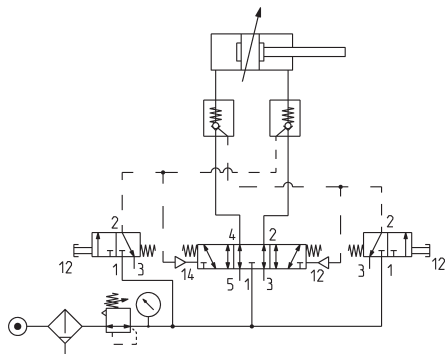
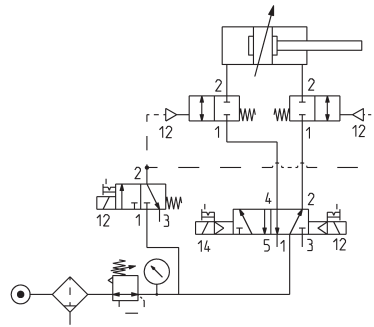
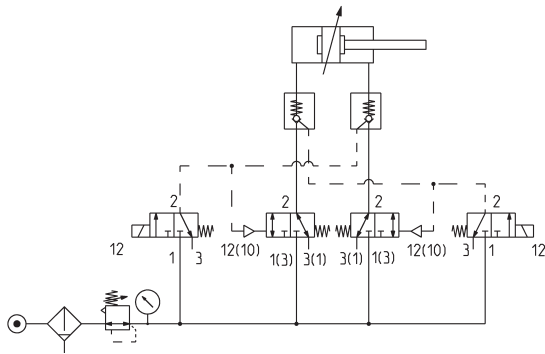

Diagram for valves VBU and VBO with G1/2 ports.

Q is the flow measured in NI/min and determined with an inlet pressure of 6 bar.

APPLICATION SCHEMES

VBU = UNIDIRECTIONAL blocking valve
VBO = BIDIRECTIONAL blocking valve



Unidirectional blocking valve

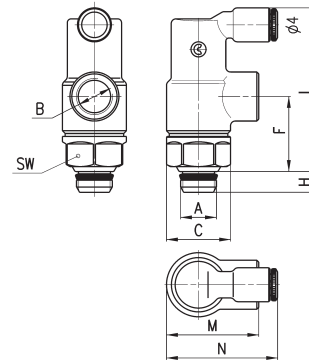

| DIMENSIONS | | | | | | | | | |
|----------------|-----|-----|------|------|-----|------|------|------|----|
| Mod. | A | B | C | F | H | L | M | N | SW |
| VBU 1/8 | 1/8 | 1/8 | 16,9 | 20 | 5,5 | 43 | 24,5 | 30 | 15 |
| VBU 1/4 | 1/4 | 1/4 | 20,5 | 25 | 7 | 50 | 32,2 | 33,5 | 19 |
| VBU 3/8 | 3/8 | 3/8 | 26,8 | 33 | 8 | 67 | 40 | 39,5 | 24 |
| VBU 1/2 | 1/2 | 1/2 | 30 | 45,5 | 9 | 85,7 | 52 | 48 | 27 |

Bidirectional blocking valve

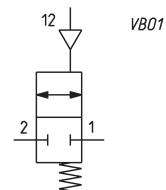
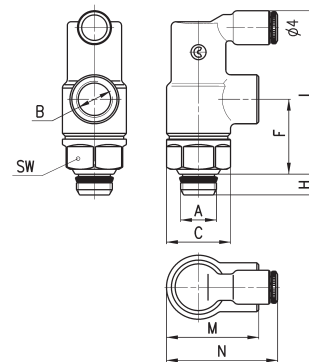

| DIMENSIONS | | | | | | | | | |
|----------------|-----|-----|------|------|-----|------|------|------|----|
| Mod. | A | B | C | F | H | L | M | N | SW |
| VBO 1/8 | 1/8 | 1/8 | 16,9 | 20 | 5,5 | 43 | 24,5 | 30 | 15 |
| VBO 1/4 | 1/4 | 1/4 | 20,5 | 25 | 7 | 50 | 32,2 | 33,5 | 19 |
| VBO 3/8 | 3/8 | 3/8 | 26,8 | 33 | 8 | 67 | 40 | 39,5 | 24 |
| VBO 1/2 | 1/2 | 1/2 | 30 | 45,5 | 9 | 85,7 | 52 | 48 | 27 |