

Motor-Verbindungs-Kit, parallel, Mod. PM - Mod. PM

Produktcode: PM-5E-50-0024

Datenblatt Erstellungsdatum: 21.05.26 09:27

Überprüfen Sie das aktualisierte Dokument  [klicken](#)



TECHNISCHE DATEN

Mod.	PM-5E-50-0024
Durchmesser	50
Schutz	IP40
Gewicht (g)	530
Effizienz	0.62

Motor-Verbindungs-Kit, parallel, Mod. PM - Mod. PM

Produktcode: PM-5E-50-0024

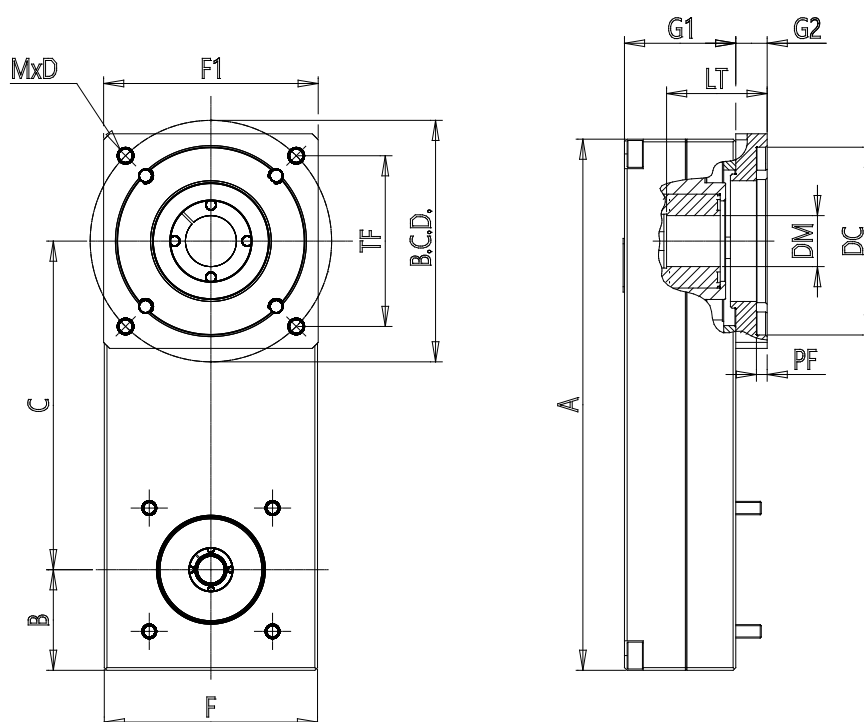

MAßE

DC (mm)	38.1
DM (mm)	8
LT (mm)	22.5
BCD (mm)	0
TF (mm)	47.1
MxD	M4x6
PF (mm)	2.5
F (mm)	49.5
F1 (mm)	60
A (mm)	122.5
B (mm)	24.8
C (mm)	72.5
G1 (mm)	37.0
G2 (mm)	6.7
J (kg*mm ²)	42.94