

Motor-Verbindungs-Kit, parallel, Mod. PM - Mod. PM

Produktcode: PM-5E-65-0400

Datenblatt Erstellungsdatum: 21.05.26 09:28

Überprüfen Sie das aktualisierte Dokument  [klicken](#)



TECHNISCHE DATEN

| | |
|--------------------|---------------|
| Mod. | PM-5E-65-0400 |
| Durchmesser | 65 |
| Schutz | IP40 |
| Gewicht (g) | 990 |
| Effizienz | 0.62 |

Motor-Verbindungs-Kit, parallel, Mod. PM - Mod. PM

Produktcode: PM-5E-65-0400

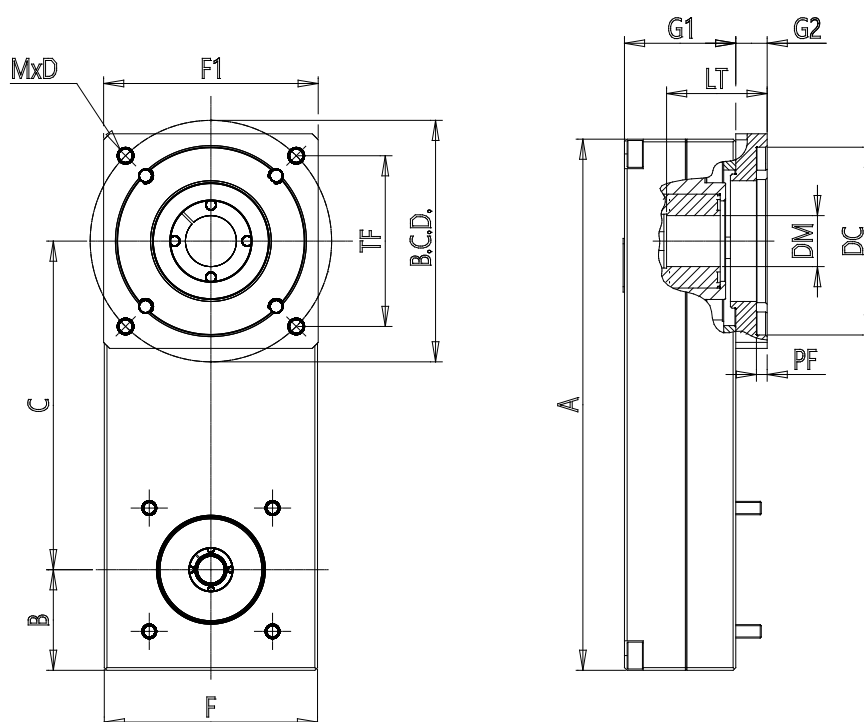

MAßE

| | |
|-------------------------|--------|
| DC (mm) | 50.0 |
| DM (mm) | 14 |
| LT (mm) | 26.5 |
| BCD (mm) | 70 |
| TF (mm) | 0.0 |
| MxD | M5x10 |
| PF (mm) | 4.0 |
| F (mm) | 64.5 |
| F1 (mm) | 0 |
| A (mm) | 164.5 |
| B (mm) | 32.0 |
| C (mm) | 94.5 |
| G1 (mm) | 42.0 |
| G2 (mm) | 0.0 |
| J (kg*mm ²) | 175.10 |