

Mod. SMS-5V - Sensorhalter-Kit

Produktcode: SMS-5V-5050

Datenblatt Erstellungsdatum: 21.05.26 09:47

Überprüfen Sie das aktualisierte Dokument  [klicken](#)

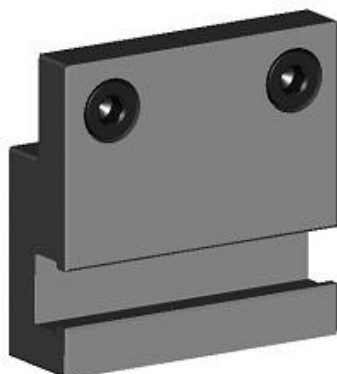

TECHNISCHE DATEN

Mod.	SMS-5V-50
Größe	50

Mod. SMS-5V - Sensorhalter-Kit

Produktcode: SMS-5V-5050

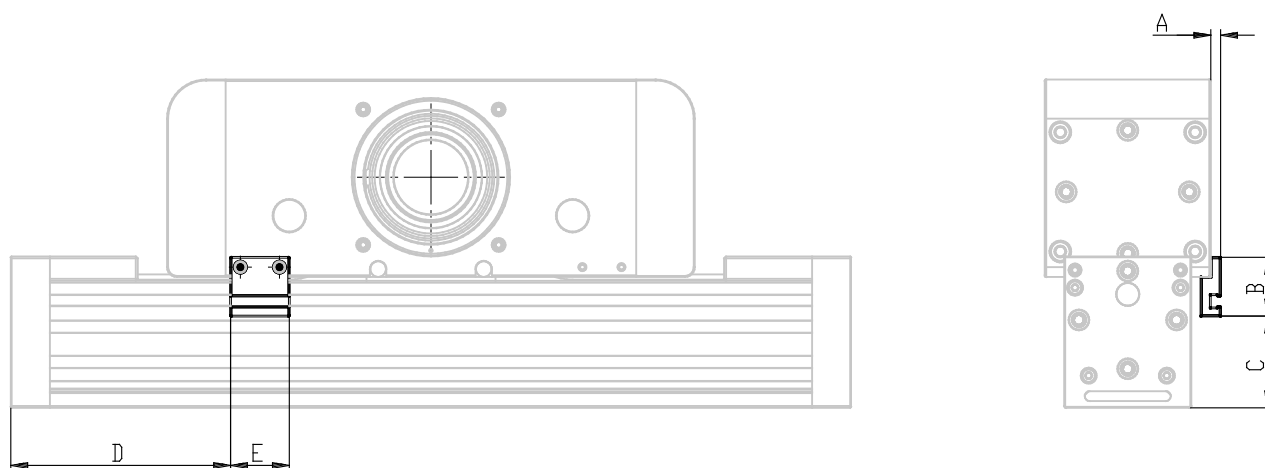

MAßE

A (mm)	7.500
B (mm)	30.000
C	32.000
D	100.000
E (mm)	30.000