

## Cylinders - aluminium profile ISO 15552 (ex DIN/ISO 6431 / VDMA 24562) - Series 61

Product code: 61M2P125A0020N

Datasheet creation date: 08/03/2025 14:32

Check the most updated document online [click here](#)



### TECHNICAL DATA

|                                      |   |
|--------------------------------------|---|
| <b>SERIE (Series / mm)</b>           | 61  |
| <b>PHY (Diameter / mm)</b>           | 125   |
| <b>VERSION (Version)</b>             | M = magnetic standard   |
| <b>FUNZ (Operation)</b>              | 2=double acting (front and rear cushions)   |
| <b>MAT (Materials)</b>               | P = standard: AL end-blocks and piston, rolled stainless steel AISI 420B rod, anodized AL profile tube, zinc-plated steel tie-rods and tie-rod nuts, PU seals |
| <b>TYP (Construction)</b>            | A = standard with lock nut for rod  |
| <b>HUBT (Stroke type)</b>            | variable  |
| <b>HUB (Stroke / mm)</b>             | 20  |
| <b>ES (execution)</b>                | N = tandem  |
| <b>LSTELO (extended piston / mm)</b> | 0   |

## Cylinders - aluminium profile ISO 15552 (ex DIN/ISO 6431 / VDMA 24562) - Series 61

Product code: 61M2P125A0020N

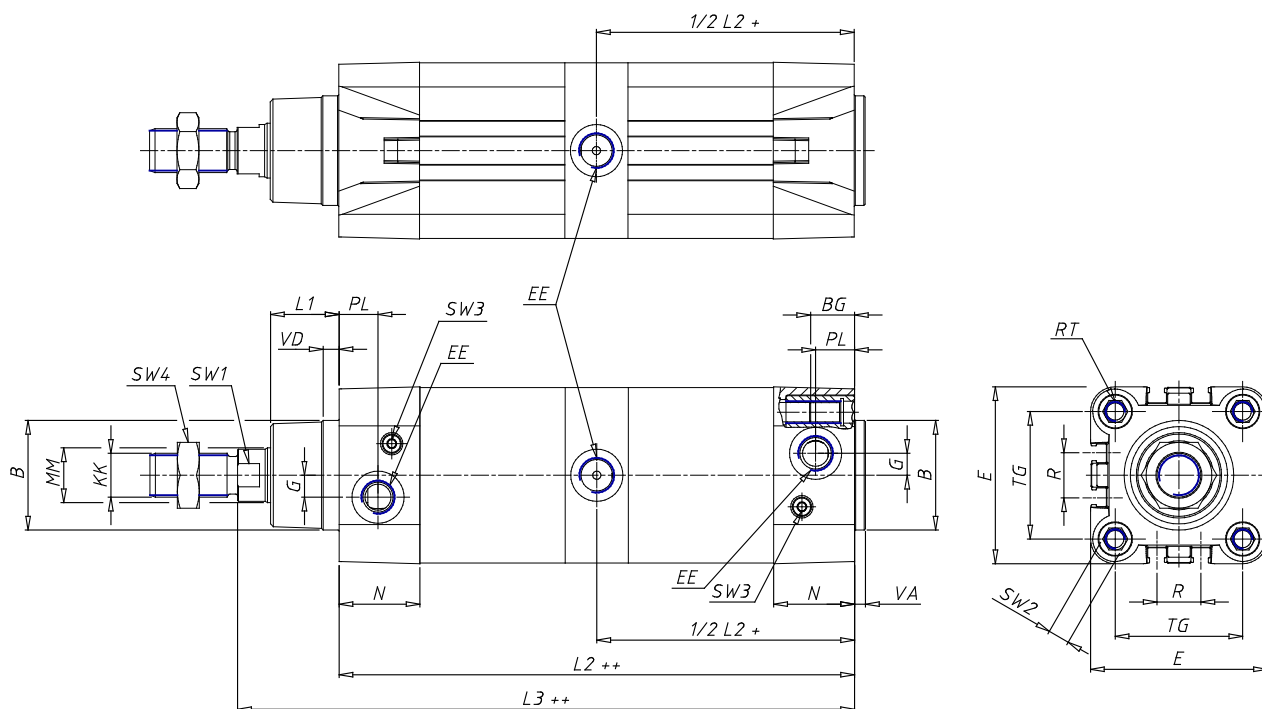

### DIMENSIONS

|                       |       |
|-----------------------|-------|
| <b>MM (MM / mm)</b>   | 32    |
| <b>KK (KK)</b>        | M27x2 |
| <b>B (B d11 / mm)</b> | 60    |
| <b>PL (PL / mm)</b>   | 23    |
| <b>L1 (L1 / mm)</b>   | 42    |
| <b>AM (AM / mm)</b>   | 54    |
| <b>VA (VA / mm)</b>   | 6     |
| <b>EE (EE)</b>        | G1/2  |
| <b>WH (WH / mm)</b>   | 65    |
| <b>L2 (L2 / mm)</b>   | 264.0 |
| <b>ZM (ZM / mm)</b>   | -     |
| <b>ZJ (ZJ / mm)</b>   | 225   |
| <b>VD (VD / mm)</b>   | 8     |
| <b>N (N / mm)</b>     | 43.0  |
| <b>BG (BG / mm)</b>   | 23.0  |
| <b>RT (RT)</b>        | M12   |
| <b>G (G / mm)</b>     | 10.5  |
| <b>TG (TG / mm)</b>   | 110.0 |
| <b>R (R / mm)</b>     | 50.0  |
| <b>E (E / mm)</b>     | 135.0 |
| <b>SW1 (SW1 / mm)</b> | 27    |
| <b>SW2 (SW2 / mm)</b> | 12    |
| <b>SW3 (SW3 / mm)</b> | 4     |

|   |          |
|---|----------|
| <b>SW4 (SW4 / mm)</b>                     | 41       |
| <b>HUBA (Cushion stroke front spring)</b> | 26       |
| <b>HUBP (Cushion stroke rear spring)</b>  | 25       |
| <b>L3 (L3 / mm)</b>                       | 329.0    |
| <b>L4 (L4 / mm)</b>                       | 22       |
| <b>L5 (L5 / mm)</b>                       | 30       |
| <b>L6 (L6 / mm)</b>                       | 51.0     |
| <b>L7 (L7 / mm)</b>                       | 86.5     |
| <b>L8 (L8 / mm)</b>                       | 140      |
| <b>L9 (L9 / mm)</b>                       | 160.0    |
| <b>L10 ( / mm)</b>                        | 350.0    |
| <b>D (ø D / mm)</b>                       | 32       |
| <b>D1 (ø D1 d11 / mm)</b>                 | 60.0     |
| <b>D2 (ø D2 / mm)</b>                     | 130      |
| <b>D3 (ø D3 f6 / mm)</b>                  | 65       |
| <b>A (± 0.15 / mm)</b>                    | 110.0    |
| <b>GX (GX)</b>                            | G1/8     |
| <b>H (H / mm)</b>                         | 80.0     |
| <b>H1 (H1 / mm)</b>                       | 150.0    |
| <b>M (M)</b>                              | M12      |
| <b>Z (Z)</b>                              | M12 x 40 |