

Cylinders ISO 15552 - Series 63

Product code: 63MP6C100A0100G

Datasheet creation date: 09/03/2025 12:55

Check the most updated document online [click here](#)



TECHNICAL DATA

| | |
|---|---|
| Series | 63 |
| Version | M = standard, magnetic |
| Costrction | P = profile tube |
| Operation | 6 = double acting through rod |
| Cushioning | C = cushioning on both sides |
| Bore (mm) | 100 |
| Construction | A = standard with lock nut for rod |
| Stroke type | = standard |
| X1 (stroke cylinders) it has to be smaller of X2 (mm) | 100 |
| X2 (stroke cylinders) it has to be greater of X1 (mm) | 0 |
| Temperature Range | = standard (-20°/+80°C) |
| Resistance to corrosion | = standard |
| Rod variants | = standard (male thread rod) |
| End caps variants | = standard |
| Variants of rod seals | = standard |
| Rod seal protection variants | G = dry and dusty environments (with brass rod scraper) |
| Bellow protection variants | = standard |
| Rod length (mm) | 0 |
| Other | = standard |
| Certifications | = standard |

Cylinders ISO 15552 - Series 63

Product code: 63MP6C100A0100G

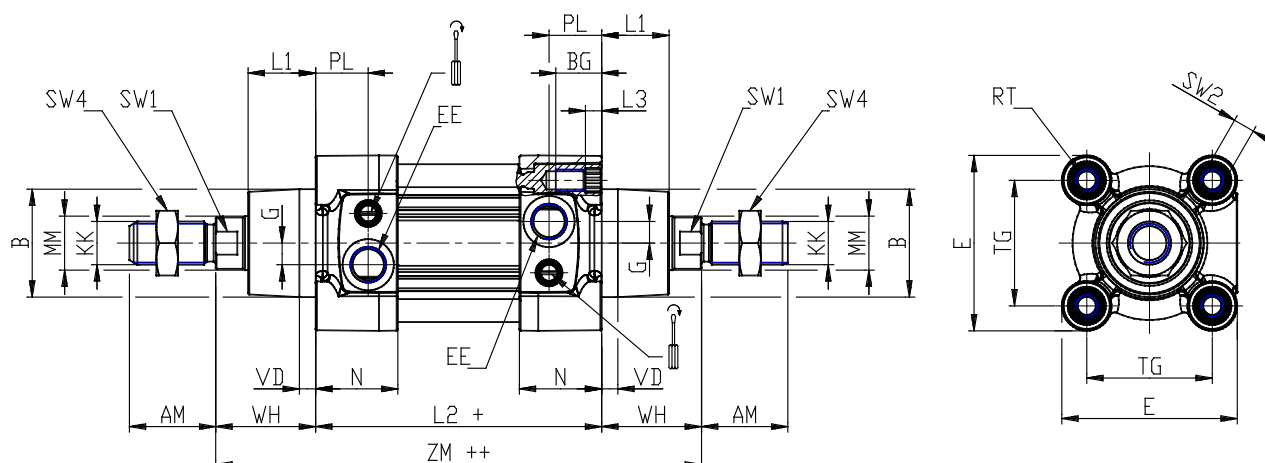

DIMENSIONS

| | |
|----------|---------|
| MM (mm) | 25 |
| KK | M20x1,5 |
| B (mm) | 55 |
| PL (mm) | 24.0 |
| L1 (mm) | 35 |
| AM (mm) | 40 |
| VA (mm) | - |
| EE | G1/2 |
| WH (mm) | 51.000 |
| L2 (mm) | 138.0 |
| L3 (mm) | 0.0 |
| L4 (mm) | 28.0 |
| ZM (mm) | 240 |
| ZJ (mm) | - |
| VD (mm) | 7 |
| N (mm) | 39.5 |
| BG (mm) | 19.5 |
| RT | M10 |
| G (mm) | 8.0 |
| TG (mm) | 89.0 |
| E (mm) | 110.0 |
| SW1 (mm) | 22 |
| SW2 (mm) | 6 |

| | |
|---------------------|-------|
| SW3 (mm) | 5 |
| SW4 (mm) | 30 |
| Cushion stroke (mm) | 30 |
| DE (mm) | 83 |
| P (mm) | 12 |
| R | G1/8 |
| LB (mm) | 18.0 |
| D1 (mm) | 55.0 |
| D2 (mm) | 100 |
| D3 (mm) | 58 |
| A (mm) | 89.0 |
| G2 | G1/8 |
| H (mm) | 58.0 |
| H1 (mm) | 110.5 |
| L1B (mm) | 115 |
| L2B (mm) | 100 |
| L3B (mm) | 15 |
| L4B (mm) | 18 |
| L5B (mm) | 20 |
| L6B (mm) | 39.0 |
| L7B (mm) | 69.0 |
| L8B (mm) | 105 |
| L9B (mm) | 138 |