

Magnetic proximity switch - Series CST,CSV e CSH

Product code: CST-532-5EX

Datasheet creation date: 10/03/2025 10:50

Check the most updated document online [click here](#)



TECHNICAL DATA

Mod.	CST-532-5EX
Description	Hall effect sensor 3 wire with 5m cable

Magnetic proximity switch - Series CST,CSV e CSH

Product code: CST-532-5EX

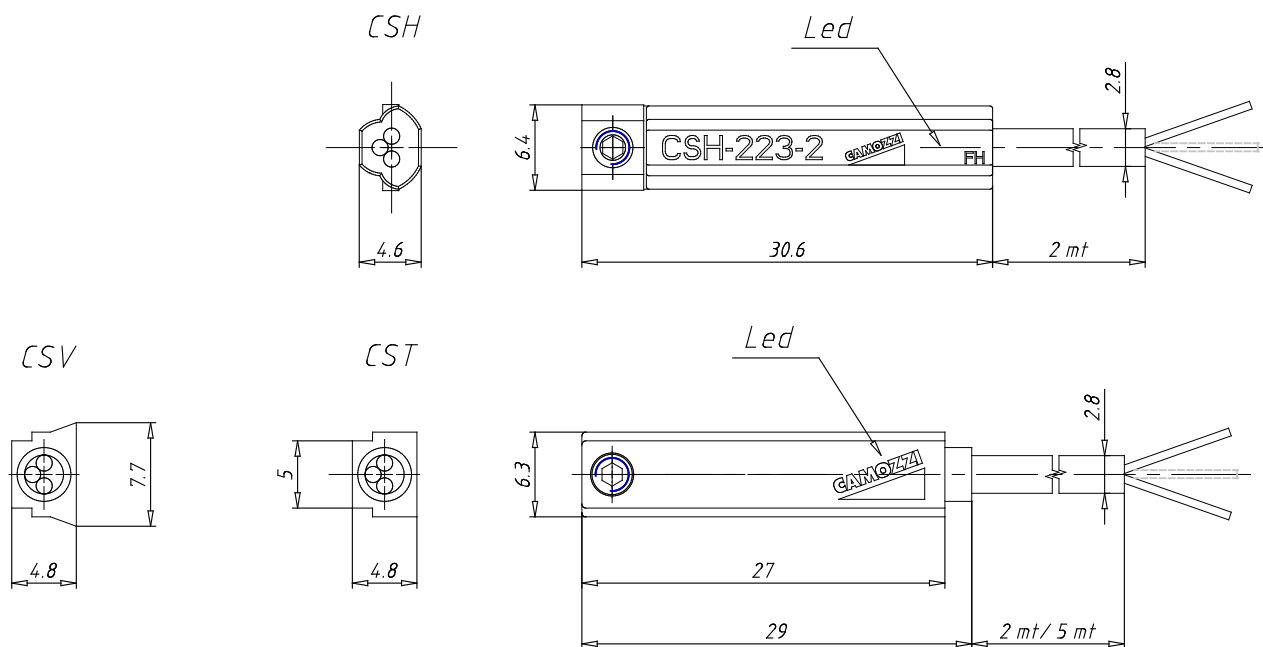

DIMENSIONS

Mod.	CST-532-5EX
Description	Hall effect sensor 3 wire with 5m cable