

USE AND MAINTENANCE MANUAL



SERIES 3E
ELECTROMECHANICAL CYLINDERS



Contents

i.	Introduction	3
1.	General safety warnings	3
2.	Reference documents	3
3.	Componenets and materials	4
4.	Coding example	4
5.	Transport and packaging	5
6.	Storage	5
7.	Assembly	5
	Installation conditions	6
	Loads not allowed	6
	Assembly position	6
	Accessory assembly	7
	Possible support configurations	8
	Assembly of rod accessories	9
	Assembly with in-line motor	9
	Assembly the flexible coupling	11
	In-parallel assembly	12
	Parts list for assembly with in-parallel motor	13
	Assembly of self-centring locking device and pulley adjustment	14
	Assembly and adjustment of the position of the CSD magnetic proximity swithces	14
	Commissioning	14
8.	Maintenance and repair	15
9.	Disassembly and parts replacement	15
10.	Disposal	15
11.	Technical information	15
12.	Resolution of possible failures	15



i. Introduction

This user manual must be read completely before starting assembly and commissioning of the Series 3E electromechanical cylinder. This document provides information on some specific product features but does not intervene on the correct application of the product under certain conditions.

The final user must perform controls and assessments necessary to validate the use of the product.

© All rights of reproduction, distribution and use of this document are property of Camozzi Automation S.p.A.
The original instructions were written in Italian.

1. General safety warnings

- All provisions, laws and regulations valid in the place of destination of the product must always be observed.
- Series 3E electromechanical cylinder must be used free from tampering or damage and in the original condition of delivery.
- The general catalogue Series 3E (available on our website) defines the limits of use within which this cylinder must be applied.
- The products indicated in this document are subject to performance deterioration due to wear of the components subjected to the loads and expected working conditions or to aging of the components.
- This document provides warnings relating to the Series 3E electromechanical cylinder.
Assessment of any interactions with other components, objects or persons inside a machine or application has to be carried out by the designer and installer of the machine or application.
- Some hazards can only be associated with the product after it has been installed on the machine/equipment. It is the responsibility of the end user to identify these hazards and reduce the risks associated with them.
- Series 3E electromechanical cylinders are designed for industrial use, they are not suitable for potentially explosive environments and for underwater use.
- When using Series 3E electromechanical cylinder in potentially corrosive environments, consult Camozzi Automation S.p.A.
- Avoid covering Series 3E electromechanical cylinder with paint or other substances; do not use in direct contact with corrosive gases, chemicals, acids, salt water or steam.
- Protection class IP40 is guaranteed only and exclusively when using dedicated accessories.

2. Reference documents

Before installing the Series 3E electromechanical cylinder, the installation engineer must ensure the following documentation is at disposal:

Title of document	Application
Instruction sheet (supplied in the packing)	Basic information
Series 3E electromechanical cylinders	Electric actuation catalogue
Drives Series DRCS and DRVB to control electric actuation	Electric actuation catalogue
Motors Series MTS and MTB for electric actuation	Electric actuation catalogue
Instruction sheet Drives DRWB for brushless motors	Basic information
Instruction sheet Drives DRCS for Stepper motors	Basic information
Documentation relating to the application in the system and instructions of other components	[1] -

[1] - In case of installation on board a machine or inside an application, make sure you have all documentation at hand relating to that application, in order to be able to assess any risks to objects, persons or animals.

3. Components and materials

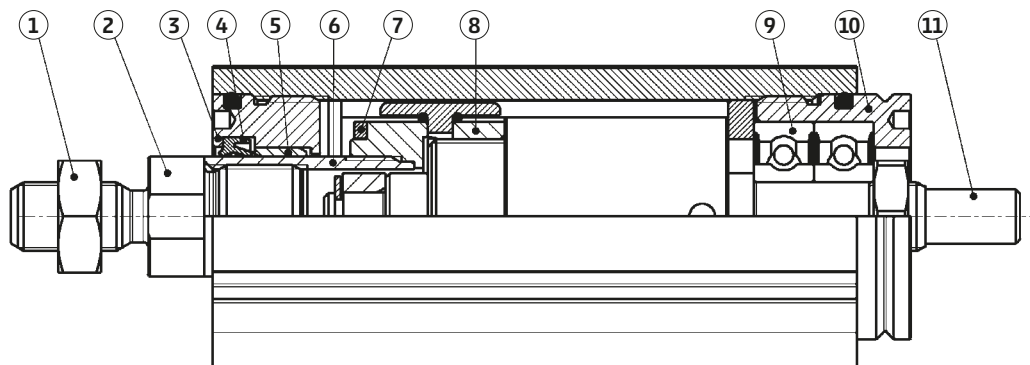

LIST OF COMPONENTS

PARTS	MATERIAL
1 Rod nut	Zinc-plated steel
2 Front coupling piece	Anodized aluminium alloy
3 Front coupling piece	Stainless steel
4 Rod seal	PU
5 Bushing	Technopolymer
6 Rod	Stainless steel
7 Magnet	Plastoferrite
8 Guiding element BS screw	Aluminium alloy
9 Bearing	Steel
10 Rear end cap	Anodized aluminium alloy
11 BS ball screw	Steel

4. Coding example

3E	020	BS	0100	P10	M	/	AM	E	0	0	-	EC	SF
-----------	------------	-----------	-------------	------------	----------	----------	-----------	----------	----------	----------	----------	-----------	-----------

3E

SERIES

020SIZE
020 = 20
032 = 32**BS**TRANSMISSION
BS = recirculating ball screw**0100**STROKE
See table of mechanical characteristics**P10**SCREW PITCH
P03 = 3 mm
P10 = 10 mm**M**CONSTRUCTION
M = male
F = femaleEXTENDED ROD
(___) = rod extended with ___ mm**AM**MOTOR CONNECTION
AM = Kit Mod. AM
PM = Kit Mod. PM**E**MOTOR
A = MTS 17
B = MTS 23
C = MTS 24
E = DRVI-23ST (for size 32 only)
F = DRVI-24ST (for size 32 only)
G = DRVI-24EC (for size 32 only)**0**BRAKE
0 = without brake
B = with brake**0**ENCODER VARIANTS
0 = without encoder (for motor A, B, C only)**EC**TYPE OF COMMUNICATION (for motor E, F, G only)
PN = Profinet
CO = CanOpen
EC = Ethercat
EI = Ethernet IP**SF**ADDITIONAL FUNCTIONS (for motor E, F, G only)
= No additional function
SF = STO

5. Transport and packaging

The product packaging is suitable for handling and lifting with warehouse equipment. Check the integrity of the packaging before handling.

Accidental falling and/or crushing of the packaging may compromise the functionality of the product and cause serious injury to the handler.

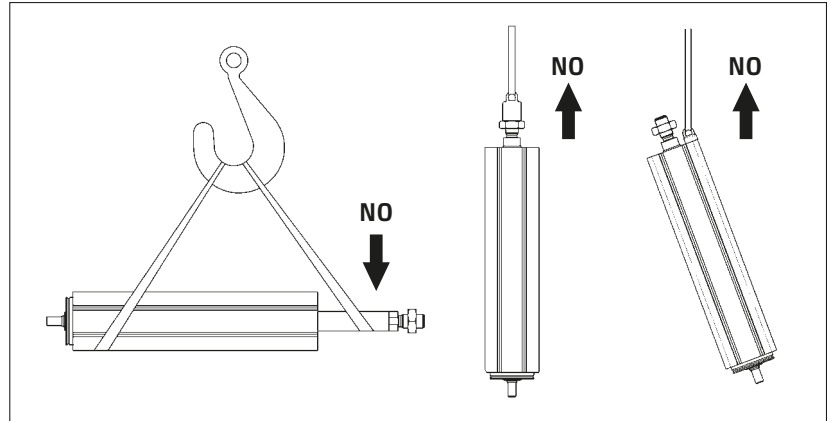
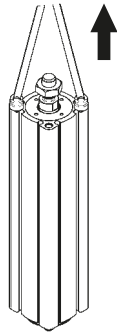
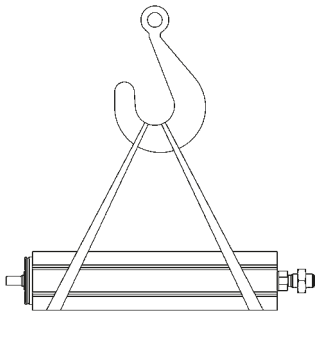

- The product must always be handled with the rod completely retracted.
- The product may only be lifted at the points shown in the figure.
- It is forbidden to use the rod for lifting the Series 3E electromechanical cylinder.

- It is forbidden to use the rear end cap to lift the product, in order to prevent the rod from coming out of the cylinder body due to the reversibility of the recirculating ball screws.

6. Storage

- The product must be stored in a dry environment protected from severe weather conditions
- Storage temperatures must be between -20°C and +80°C

7. Assembly

When installing the component, make sure that there is no danger due to possible uncontrolled mechanical movements.

The Series 3E electromechanical cylinder can only be installed by specialised personnel or by trained personnel under the guidance and supervision of qualified personnel.

Before starting the installation, check the direction of the rotation to make the rod extend and retract.

It is strongly recommended not to paint the Series 3E electromechanical cylinder.



CAUTION: Vertical or slanted mounting of the Series 3E electromechanical cylinder, with the rod facing downwards, can be dangerous. The rod could come out of the Series 3E electromechanical cylinder at an uncontrolled speed due to the reversibility of the movement of the recirculating ball screw it contains.



CAUTION: Constraining of the actuator by any accessory must always be carried out by checking the correct alignment of the accessory to the final application.

Incorrect assembly with misalignments and/or forcing can compromise the performance and durability of the actuator.

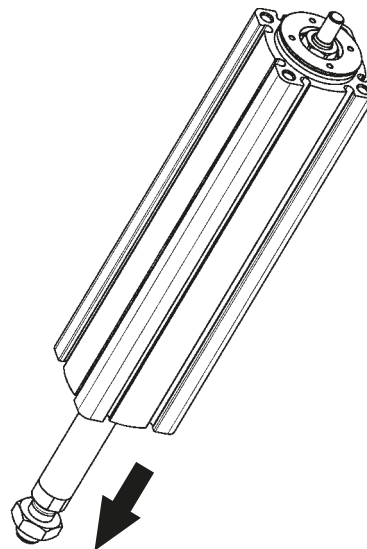
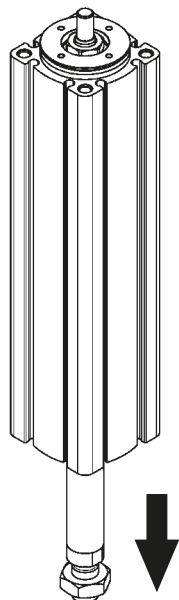

Installation conditions

The general catalogue of the Series 3E electromechanical cylinder shows the conditions for correct use and technical information.

Before starting un the Series 3E electromechanical cylinder check that:

- The declared characteristics and performance correspond to those required;
- It has not been damaged in transit;
- It is installed in such a way as not to create danger to people, things, property and/or animals;
- It is equipped with the appropriate fixing devices and is firmly fixed;
- Proper use of the assembly configurations is recommended as indicated below in the manual;
- If is exposed to the action of machine operators, provide special non-avoidable guards and/or special PPE.

Before setting up the 3E electromechanical cylinder, check that it functions correctly, if it is to be used in circuits that comply with the requirements of the ISO 13849-1 standard.

In case of different applications, contact Camozzi Automation S.p.A. During use, temperature must be between 0°C and 50°C.



CAUTION: Comply with the specified temperatures, protect against water humidity and attack by corrosive substances. Install the Series 3E electromechanical cylinder in a location accesible for maintenance so that it does not create dangers for maintenance workers.



CAUTION: due to the nature of the Series 3E electromechanical cylinder the stem is subject to movement. Provide protective devices for operators in the work area.

Assembly position

The Series 3E electromechanical cylinder can be mounted in any position: horizontal, vertical with the rod up, vertical with the rod down, slanted. Always avoid set-ups in which unexpected movements of the actuators could be hazardous to surrounding equipment and people.

In the case of vertical or slanting installation, the use of self-braking motors must be allowed to avoid uncontrolled strokes in the event of a drop in voltage.



CAUTION: It is forbidden to pass through or stop in the work area of Series 3E electromechanical cylinder.

Loads not allowed

- The Series 3E electromechanical cylinder cannot be radially loaded on the rod or on the structure.
- The structure of the Series 3E electromechanical cylinder cannot be used for assembling other components. For applications of this kind, contact Camozzi Automation S.p.A.
- The Series 3E electromechanical cylinder has an internal anti-rotation mechanism but cannot withstand torsion on the rod:

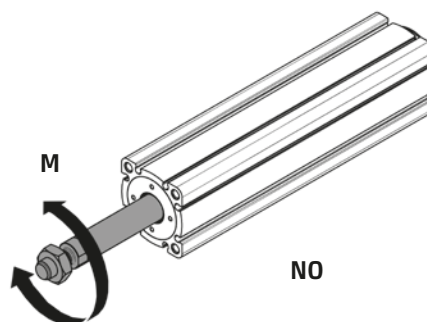
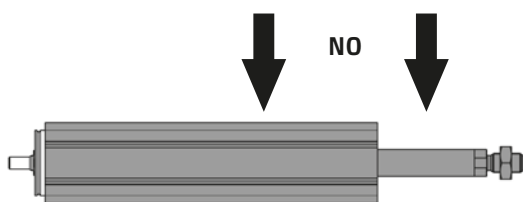

Accessory assembly

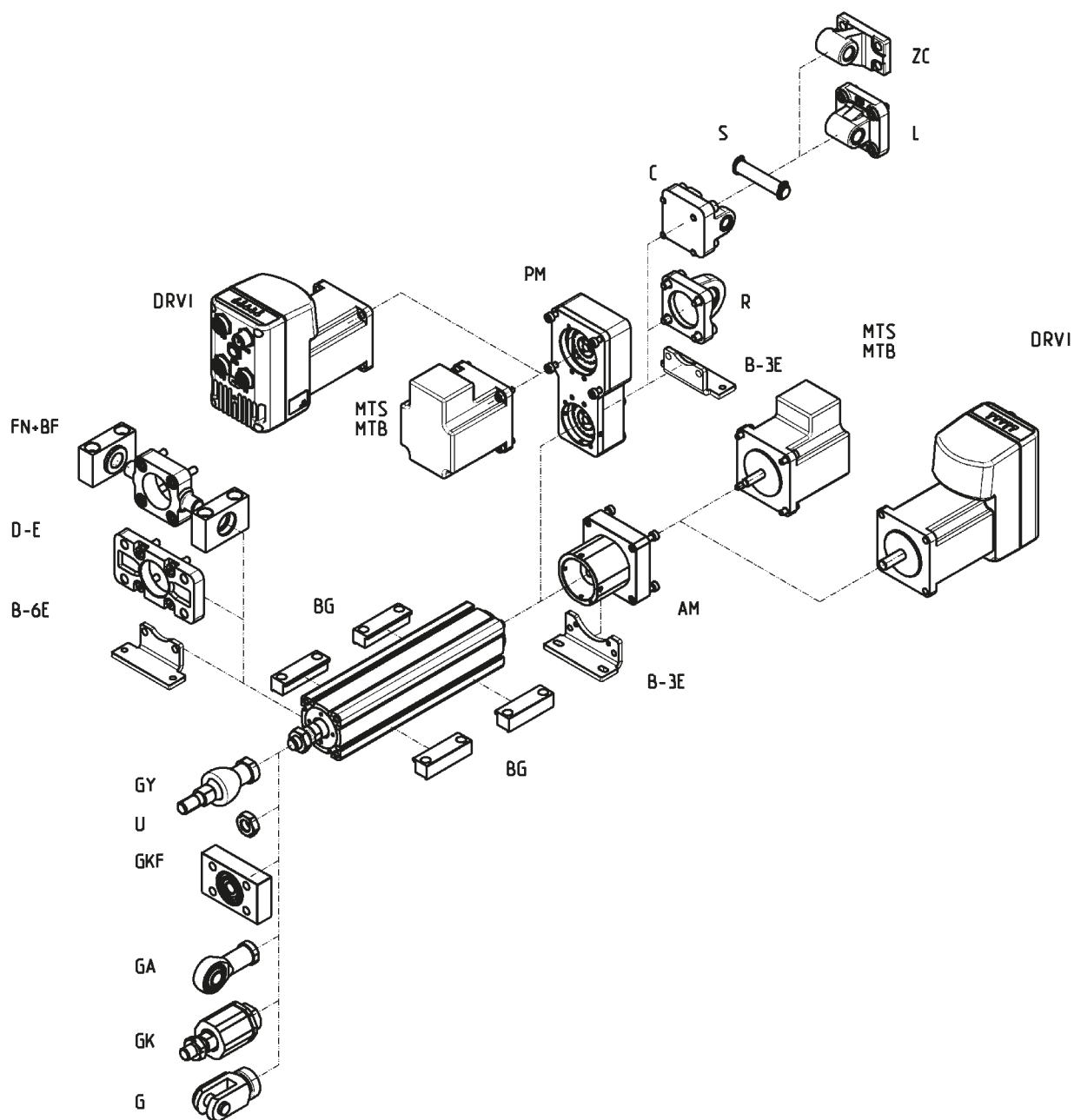

Possible support configurations

The Series 3E electromechanical cylinder can be fixed with the appropriate supports:

- 1 - On the front end cap of the Series 3E electromechanical cylinder;
- 2 - On the housing of the configuration with in-line motor;
- 3 - On the cover unit in the in-parallel motor configuration.

CAUTION: In the support is assembled with in-parallel motor configuration or in-line motor configuration for the NEMA 17 stepper motor, specific screws will be supplied together with the support to replace those already present in the kit.

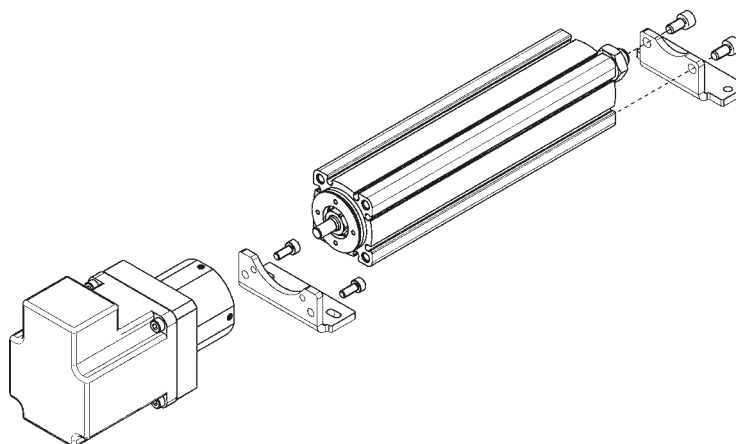

MODEL	SIZE	MOTOR	CYLINDER SIDE SCREW	MOTOR SIDE SCREW
B-3E-20-AM	20	MTS-17-...	M4x10 UNI 5931	M3x22 UNI 5931
B-3E-32-AM-1	32	MTS-23-... / MTS-24-...	M5x10 UNI 5931	M4x10 UNI 5931
B-3E-32-AM-2	32	MTB-010-...	M5x10 UNI 5931	M3x10 UNI 5931

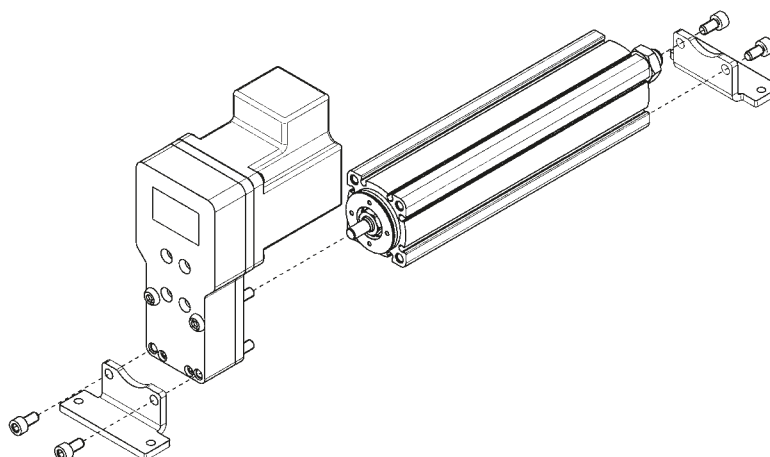

MODEL	SIZE	MOTOR	CYLINDER SIDE SCREW	ENGINE SIDE SCREW
B-3E-20-AM	20	MTS-17-...	M4x10 UNI 5931	M5x10 UNI 5931
B-3E-32-AM-1	32	MTS-23-... / MTS-24-... / MTB-010-...	M5x10 UNI 5931	M5x10 UNI 5931

Additionally, it is also possible to secure the Series 3E electromechanical cylinder with the clamping brackets as shown in the figure below.

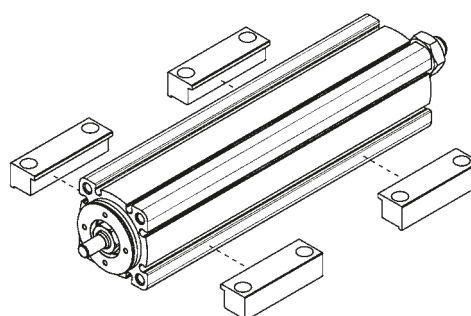

Assembly of rod accessories

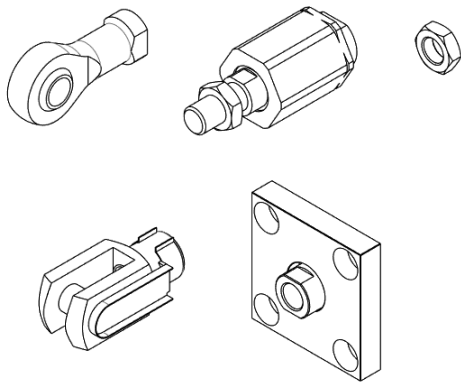

- It is forbidden to subject the cylinder rod to the torsion generated by the tightening torque of the front accessories.

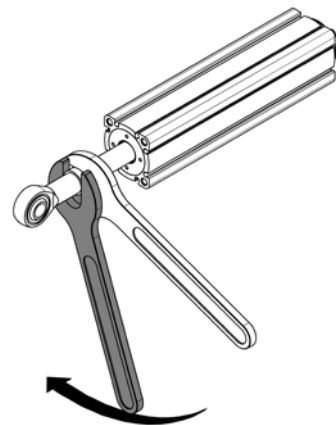

Assembly with in-line motor

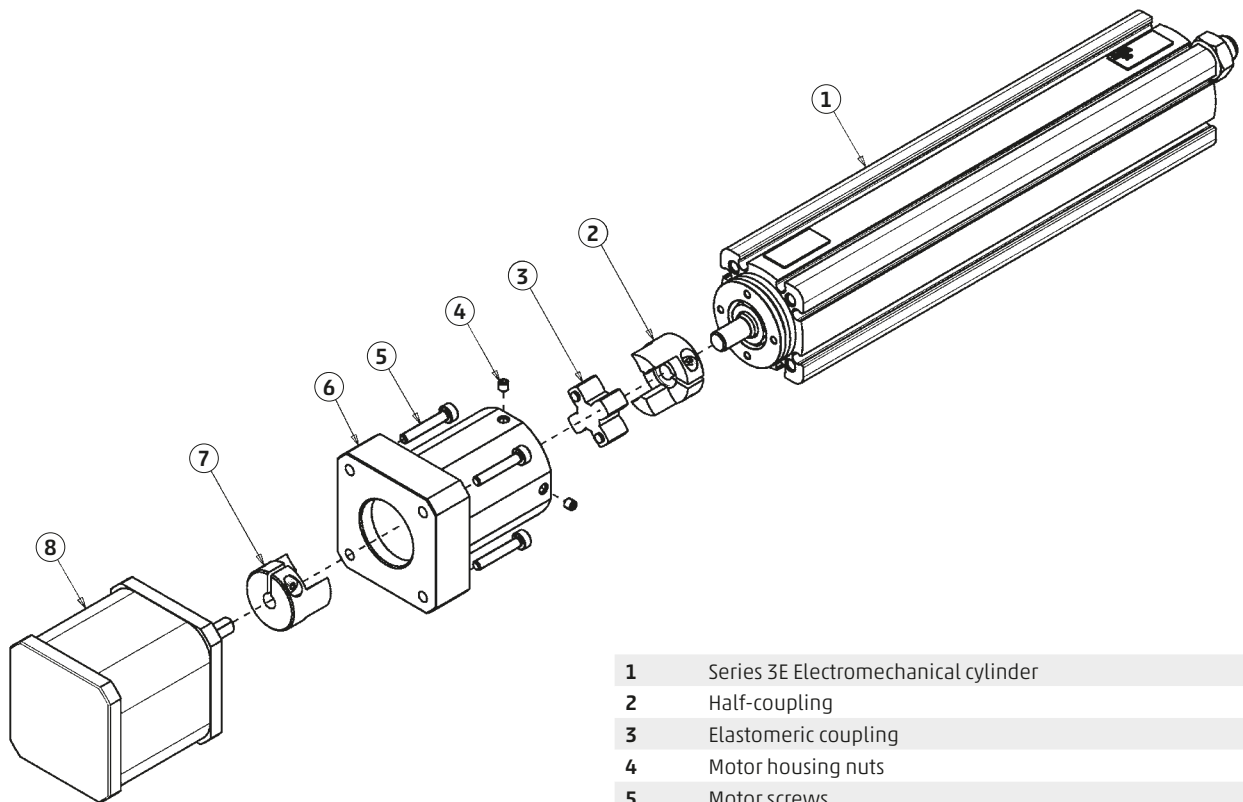

1	Series 3E Electromechanical cylinder
2	Half-coupling
3	Elastomeric coupling
4	Motor housing nuts
5	Motor screws
6	Housing
7	Half-coupling
8	Motor

STEP 1

After having correctly positioned the Series 3E electromechanical cylinder (1), assemble the half-coupling (2) on the rear shaft of the cylinder and lock it with the appropriate screw as indicated in the "Assembling the flexible coupling" section. Then fit the elastomer (3).

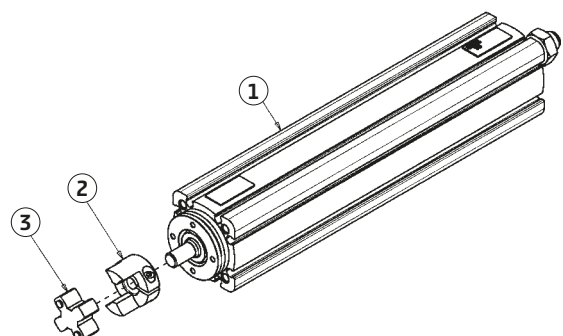

STEP 2

Following the same procedure as previously, assemble the half-coupling (7) onto the motor shaft (8).

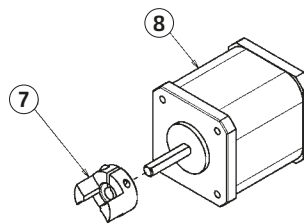
**STEP 3**

Once the various parts have been pre-assembled, proceed by fixing the motor housing (6), on the Series 3E electromechanical cylinder (1) tightening the nuts (4).

Recommended nut tightening torque 0,6 Nm.

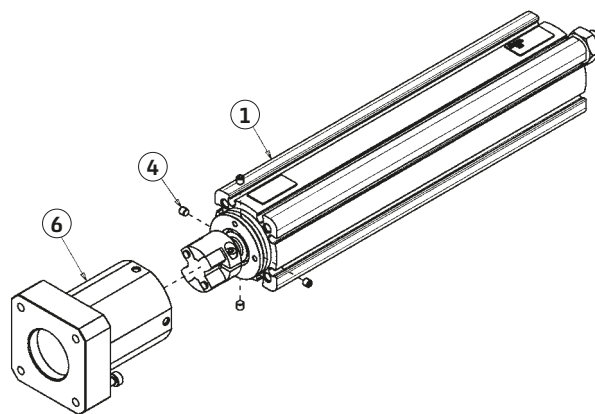
**STEP 4**

Finish the assembly by mounting the motor unit (8) on the housing (6) using the appropriate centring device, paying particular attention to the connecting of the half-coupling with the elastomer. Lock the motor unit with the screws (5) supplied.

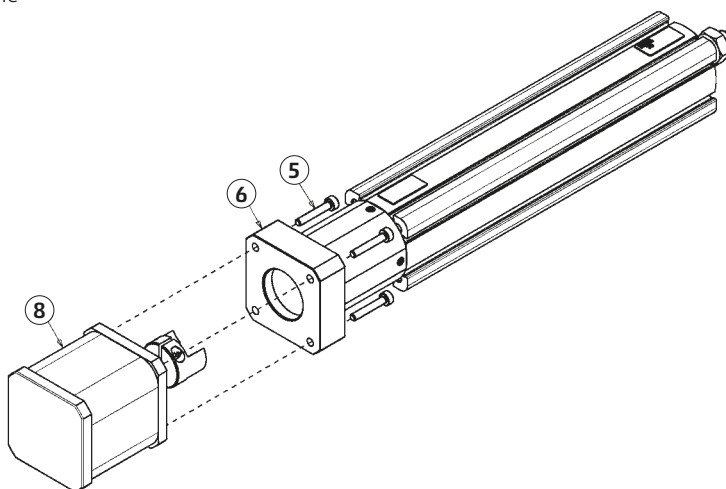

Parts list for assembly with motor/gearbox in line

	AM-3E-20-0017P	AM-3E-32-0023P	AM-3E-32-0024P	AM-3E-32-0100P
4 Cylinder fixing nuts	3x GRANO M3X3 DIN 913	3x GRANO M3X3 DIN 913	3x GRANO M3X3 DIN 913	3x GRANO M3X3 DIN 913
5 Motor screws	4x VITE M3X18 UNI5931	4x VITE M4X10 UNI 5931	4x VITE M4X12 UNI 5931	4x VITE M3X18 UNI5931

Assembling the flexible coupling

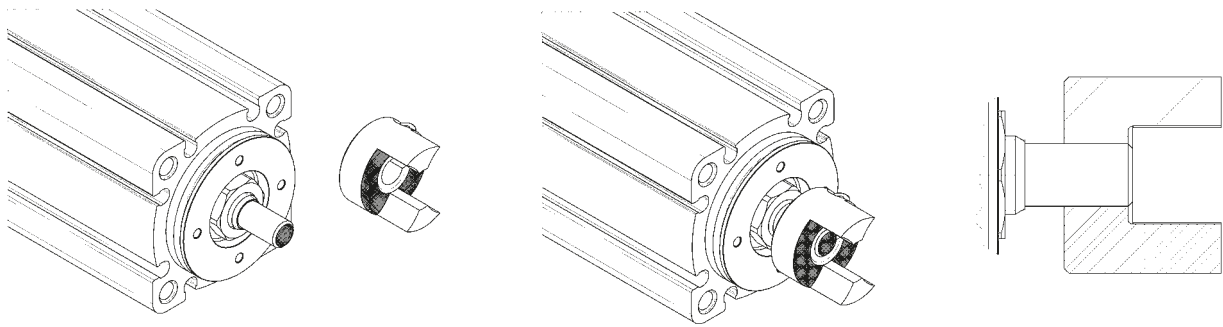

For proper operation, assemble the half-coupling so that the cylindrical part is fully engaged and aligned with the motor shaft and/or cylinder. In the image you can see the correct position, where the highlighted parts are perfectly aligned. Then fix the half-coupling by tightening the screw according to the torque shown in the table.

NB: the connection kits for in-line motor connection of the Series 3E are designed to connect motors and cylinder within an ideal assembly of all the parts. If a motor not included in the Camozzi catalogue is to be connected, the connection cannot be guaranteed.

MODEL	SIZE	MOTOR	SCREWS	WRENCH	TIGHTENING TORQUE [Nm]
AM-3E-20-0017	20	MTS-17-...	M2,5	CH.2	0,85
AM-3E-32-0023	32	MTS-23-...	M2,5	CH.2	0,85
AM-3E-32-0024	32	MTS-24-...	M2,5	CH.2	0,85
AM-3E-32-0100	32	MTB-010-...	M2,5	CH.2	0,85

In-parallel assembly

- 1 Series 3E electromechanical cylinder
- 2 Motor
- 3 Cylinder locking set
- 4 Cylinder pulley
- 5 Front flange
- 6 Motor screws
- 7 Cylinder screws
- 8 Motor pulley
- 9 Belt
- 10 Motor locking set
- 11 Rear cover
- 12 Kit closing screws
- 13 Bracket fixing screws

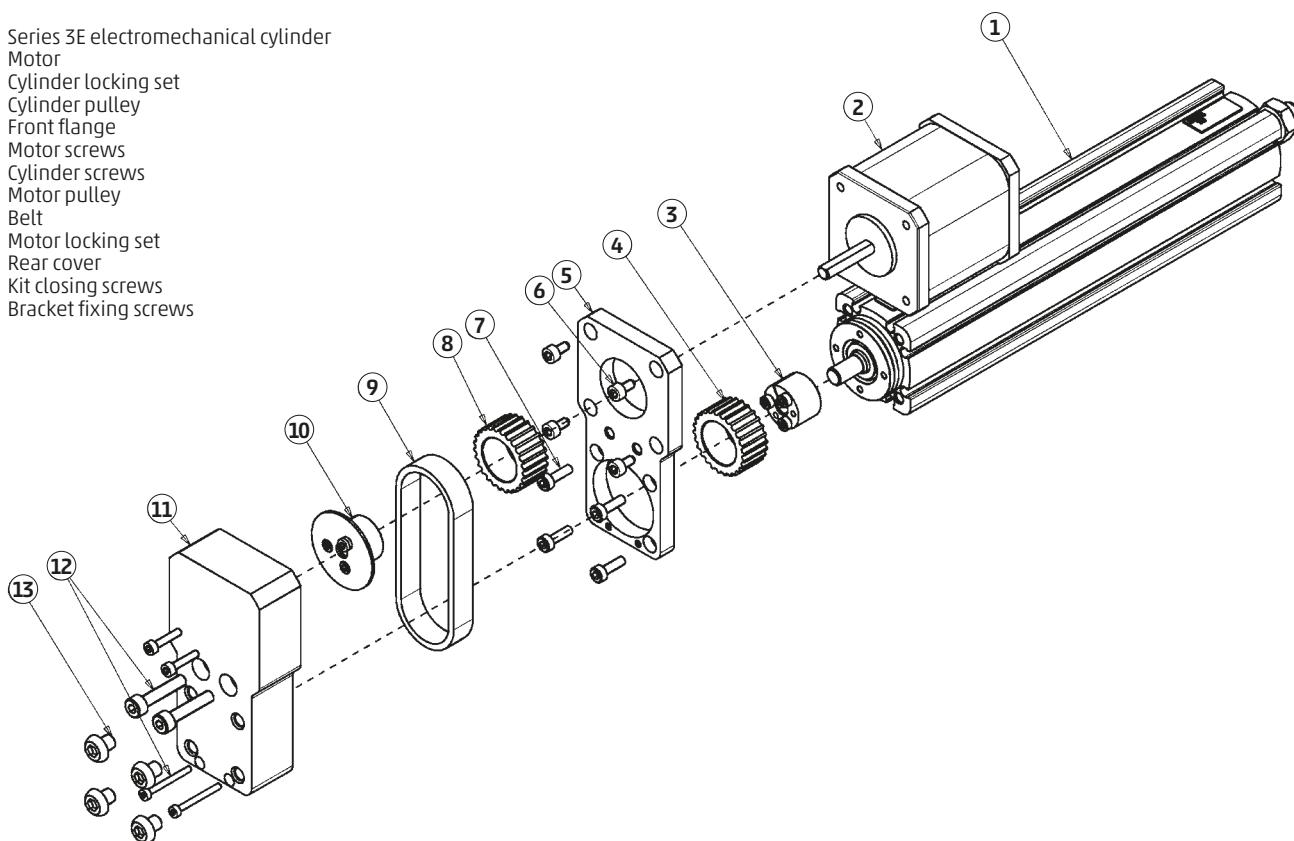

STEP 1

Assemble the pulley (4) and the locking set (3) on the tang of the Series 3E cylinder (1) according to the instructions in the paragraph "ASSEMBLING NON SELF-CENTRING LOCKING SETS".

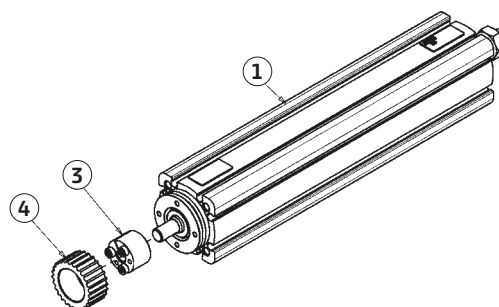

STEP 2

Proceed by fixing the front flange (5), onto the Series 3E electromechanical cylinder (1).

As shown in the diagram, the cylinder is equipped with a pin on the rear interface, designed to guarantee the correct orientation of the accessory during assembly.

Then proceed by tightening the screws (7) to fix the motor flange (5) in position.

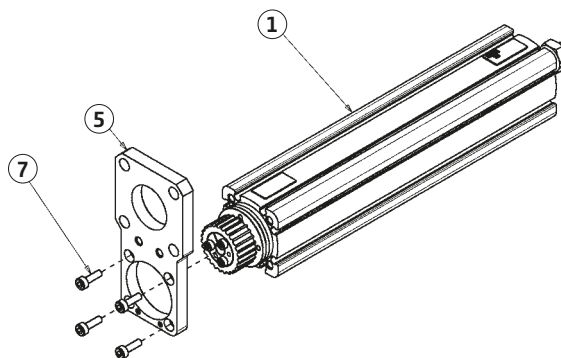

STEP 3

Continue assembling the kit by assembling the motor pulley (8) and the locking set (10) on the motor shaft (2) according to the instructions in the paragraph "ASSEMBLING THE SELF-CENTRING LOCKING SET AND ADJUSTING THE PULLEY".

NB: if you are assembling a PM-3E-20-0017 kit for connecting a NEMA 17 stepper motor with the size 20 Series 3E electromechanical cylinder, this step must be carried out by fitting the motor (2) in advance in the front flange (5).

For any other in-parallel connection kit it is possible to pre-assemble the pulley (8) and the locking set (10) on the motor and then fit everything on the flange (5).

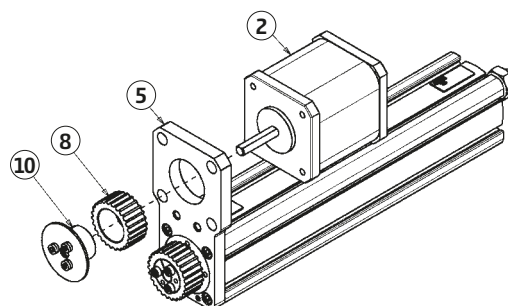

STEP 4

At this point we recommend to place the belt (9) on the motor pulley (8) and then position it on the cylinder pulley (4). It might be helpful to tilt the motor (2) as shown in the picture.

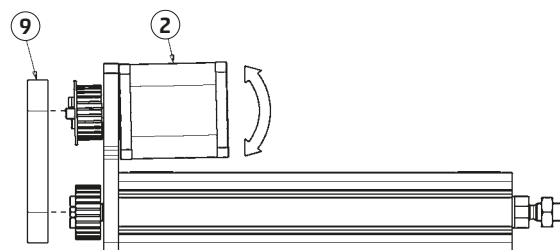
**STEP 5**

Once the belt has been fitted, fix the motor (2), to the front flange (5) with the screws (6).

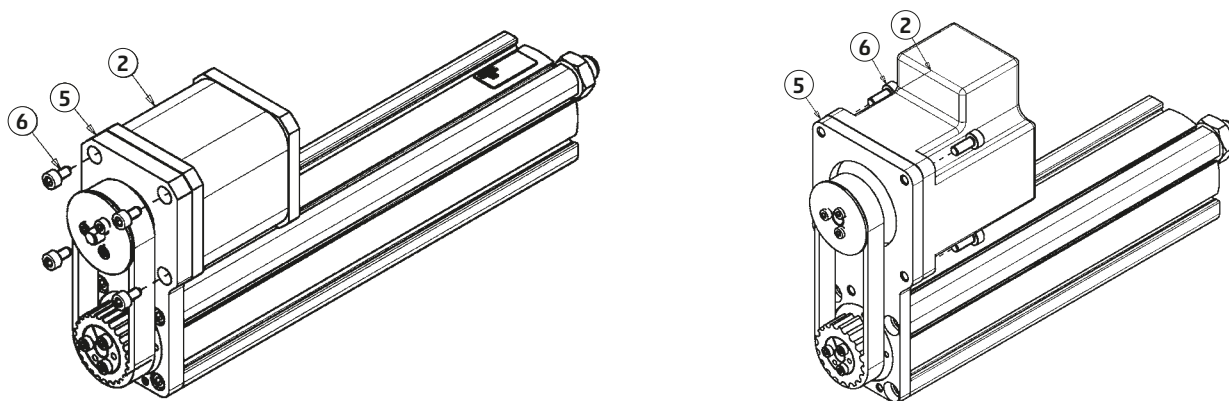
**STEP 6**

Finish the assembly by closing the transmission with the rear cover in place (11), fixing it in position with the screws (12). Lastly, using the screws (13) close the holes provided for the rear fixings.

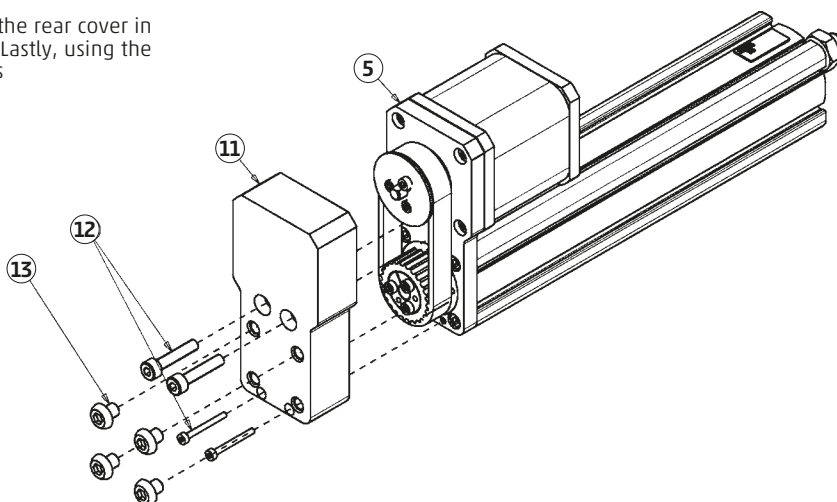
**Parts list for assembly with in-parallel motor**

	PM-3E-20-0017P	PM-3E-32-0023P	PM-3E-32-0024P	PM-3E-32-0100P
3 Cylinder locking set	1x LOCKING SET SELF-CENTRING 5X16	1x LOCKING SET SELF-CENTRING 5X16	1x LOCKING SET SELF-CENTRING 5X16	1x LOCKING SET SELF-CENTRING 5X16
6 Motor screws	4 x SCREW M3X6 UNI 5931	4 x SCREW M4X10 UNI 5931	4 x SCREW M4X12 UNI 5931	4 x SCREW M3X16 UNI 5931
7 Motor screws	4x VITE M3X10 UNI 5931	4x VITE M5x12 UNI 9327	4x VITE M5x12 UNI 9327	4x VITE M5x12 UNI 9327
12 Kit closing screws	2 x SCREW M4X20 UNI 5931 + 2 x SCREW M2X20 UNI 5931	4 x SCREW M4X20 UNI 5931 + 2 x SCREW M3X22 UNI 5931	4 x SCREW M4X20 UNI 5931 + 2 x SCREW M3X22 UNI 5931	2 x SCREW M4X20 UNI 5931 + 2 x SCREW M3X22 UNI 5931
13 Bracket fixing screws	4 x SCREW M5x6 ISO 7380-1	4 x SCREW M5x6 ISO 7380-1	4 x SCREW M5x6 ISO 7380-1	4 x SCREW M5x6 ISO 7380-1

Assembly of self-centring locking device and pulley adjustment

Check that all contact surfaces are clean and lightly oiled (do not use "Molykote" or molybdenum disulphide based lubricants). Position the locking set on the pulley hub, taking care to keep all the locking set within the DC length of the hub. Assemble it on the motor shaft taking care to maintain the dimension (DC) as indicated in the table. It is sufficient to fit it on the cylinder shaft up to the rabbet on the tang, making sure not to force it axially.

MODEL	SIZE	MOTOR	DC
PM-3E-20-0017P	20	MTS-17-...	4
PM-3E-32-0023P	32	MTS-23-...	0,6 ÷ 1
PM-3E-32-0024P	32	MTS-24-...	0,6 ÷ 1
PM-3E-32-0100P	32	MTB-010-...	5

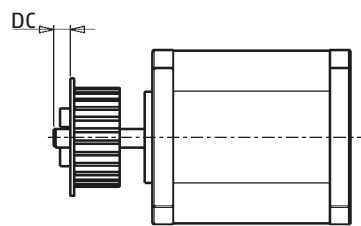

Then tighten gradually and evenly, according to the tightening torques (MS) shown in the table.

Being careful to pass from one screw to its opposite (cross diagram), proceed as follows:

- hand tighten the assembly screws until contact is made with the surface
- check the positioning of the hub on the shaft
- tighten the screws to approximately half of the recommended MS tightening torque
- repeat the operation until the recommended tightening torque is reached, using the torque wrench
- check that all screws have reached the specified tightening torque.

If the locking set is reused, screws and conical parts must be oiled d x D MS [Nm] before proceeding with assembly.

NB: the dimensions shown in the table refer to the motors in the Camozzi catalogue, the compatibility of the kits with different motors is not guaranteed.

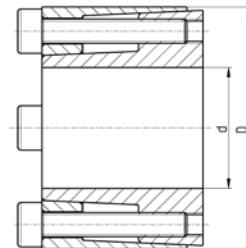

d x D	MS [Nm]
5x16	1,2
6,35x16	1,2
8x18	1,2

Assembly and adjustment of the position of the CSD magnetic proximity switches

The Series 3E cylinder is equipped with 8 sensor slots (2 per side), into which sensors (proximity switches) can be inserted axially from both the front and rear interfaces of the actuator.

For assembly, insert the switch axially into the appropriate slots on the Series 3E electromechanical cylinder.

Finally, lock by tightening the nut supplied.

NB: some accessories/kits could obstruct the slots making it impossible to insert the switch; it is therefore recommended to fit it in advance, and then fix it in position at the right moment. For reading at the limit switch, it is recommended to pay attention to the orientation of the switch, as it could protrude from the cylinder.

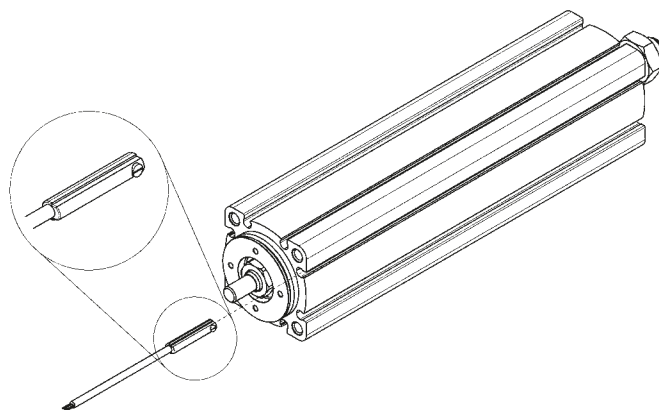

Commissioning



CAUTION: Commissioning of the Series 3E electromechanical cylinder must only take place after having ascertained that the system or the machine in which it is installed meets the country-specific regulations, safety regulations and applicable standards.

Before carrying out the electrical connection of the motor, check that the assembly of all interface components is correct.

Make sure the range of motion is free from obstacles.

Connect the electrical connection afterwards.

WARNING - Electrical hazard

- Before commissioning, make sure that all connectors are correctly connected;
- Risk of motor short circuit due to the presence of openings. Possibility of damage to the motor due to penetration of liquids and foreign objects;
- Check the correct closure of the connectors. Possibility of collision due to incorrect set-up or positioning of connectors or limit switches. Possibility of damage to the product.

WARNING - Risk of injury

- Risk of injury from moving parts;
- Do not grab moving parts during operation;
- Do not stand in the danger zone in front of the Series 3E electromechanical cylinder;

- Before starting, make sure that no one is in front of the Series 3E electromechanical cylinder;

Check that you have set up the strokes accurately to avoid collision of the product with limit switches.

- Respect the maximum stroke of the Series 3E electromechanical cylinder.
- Check that the application of the operating conditions is correct.

In particular, pay attention to: ambient temperature, load conditions number of revolutions and maximum stroke of the Series 3E electromechanical Cylinder. Precise directions are contained in the manual and in the catalogue information.

For particular operating conditions, contact the technical service. Before using the Series 3E electromechanical cylinder in production conditions, test the entire stroke at very low speed

Only put the product into operation after successfully carrying out a Functioning test under production conditions, with positive outcome.



CAUTION: The Series 3E electromechanical cylinder is not equipped with an emergency end-of-stroke cushioning system. It is recommended to avoid end-of-stroke shocks, in order to preserve the integrity of the product.

8. Maintenance and repair

Cleaning and lubrication

For cleaning Series 3E electromechanical cylinder, it is forbidden to use solvents or aggressive detergents that may damage seals or aluminium parts due to chemical incompatibility. It is however possible to use mild water-soluble detergents (in any case check compatibility of the materials used with these cleaning products).

Proceed as follows:

1. Protect the cylinder openings and holes to prevent penetration of liquid inside the cylinder;
2. Interrupt power supply to all electrical components and adequately protect connectors and all contacts against moisture.
3. Clean with a damp cloth and without using direct sprays of liquid onto the cylinder.
4. At the end of cleaning lubricate the cylinder rod and the front seal with NYE Lubricants Rheolube 363 AX 1 type grease (order code 70-7902-0032) in order to improve the system's durability.

9. Disassembly and parts replacement

In case of cylinder anomalies and the need for replacement of parts within it, refer to the Camozzi Automation S.p.A. Customer Service who will assess how to intervene and countermeasures to be taken. Disassembly and replacement of parts is only permitted by Camozzi

Automation S.p.A. staff.

For maintenance that involves opening Series 3E electromechanical cylinder, contact our customer service.

10. Disposal

In Series 3E electromechanical cylinder we can find:

- Aluminium alloy
- Steel
- Plastic material
- Grease

- Epoxy resin

Components must be disposed of in compliance with current national and international standards and directives after having collected any lubricant present and having disposed of it separately.

11. Technical information

Please, refer to the general catalogue of Series 3E electromechanical cylinders.

12. Resolution of possible failures

FAILURE	POSSIBLE CAUSE	POSSIBLE SOLUTION
Excessive axial play	Wear	Return the electromechanical cylinder Series 3E to Camozzi Automation SpA for repair or replacement
Vibration during use	Excessive wear of internal components	Return the electromechanical cylinder Series 3E to Camozzi Automation SpA for repair or replacement
	Wrong tightening of the interface accessories	Make sure all screws have been tightened properly
	Breakage of the anti-rotation system caused by radial loads applied to the rod	Application of radial loads is not permitted. Return the electromechanical cylinder Series 3E to Camozzi Automation SpA for repair or replacement
	Rod travel speed higher than the value indicated on the catalogue	Reduce the travel speed or use an electromechanical cylinder Series 3E with a bigger screw pitch (suitable for the loads to be handled)
The rod does not move	Wrong assembly of the flexible coupling	Perform assembly according to the indications given in the use and maintenance instructions
	Wrong configuration of operating parameters	Check if the parameters entered are correct and suitable for use with the electromechanical cylinder Series 3E
	Wrong positioning of the external magnetic proximity switch (if present)	Check if the switch is positioned in the right zone of the cylinder's stroke so that the full stroke is used.
	Rod travel speed higher than the value indicated on the catalogue	Reduce the belt tension, by unscrewing the set screw adequately (ref. Assembly instructions with motor in parallel)
	Environmental temperature too low	- Partially apply the payload - Operate with a reduced travel speed - Adjust the environmental temperature
	Load applied is higher than the value indicated on the catalogue	Reduce the load or replace the cylinder with one that is suitable to operate with higher loads
Overheating of the unit	Excessive absorption of torque due to wrong fixing	Make sure the fixing of the cylinder is not causing strain or misalignment with the unit
Excessive noise or change in noise	Abnormal wear	Return the electromechanical cylinder Series 3E to Camozzi Automation SpA for repair or replacement
Position error	Slipping of motor connection components	Perform the assembly of transmission components according to the indications given in the use and maintenance instructions
	Wear	Return the electromechanical cylinder Series 3E to Camozzi Automation SpA for repair or replacement
	Wrong reading of proximity switch (if present)	Check if position and connection of the proximity switch and relative accessories is performed correctly (see manual)
	Slipping of transmission components	Make sure the belt is correctly tensioned, if necessary, recalibrate it by further tightening the special nut.



CAUTION: in case of fire in the surrounding area it is recommended to extinguish with carbon dioxide CO₂

Contacts

Camozzi Automation S.p.A.

Società Unipersonale

REGISTERED OFFICE

Via R. Rubattino, 81

20134 Milano

Italy

OPERATIONAL HEADQUARTERS

Via Eritrea, 20/I

25126 Brescia

Italy

Tel. +39 030 37921

www.camozzi.com

Customer Service

Tel. +39 030 3792790

service@camozzi.com

Product Certification

Information concerning
product certifications, EC standards,
conformity declarations and instructions
productcertification@camozzi.com



Automation

