

USE AND MAINTENANCE MANUAL

V1.0



PNEUMATIC COLLABORATIVE GRIPPER

SERIE CSSP

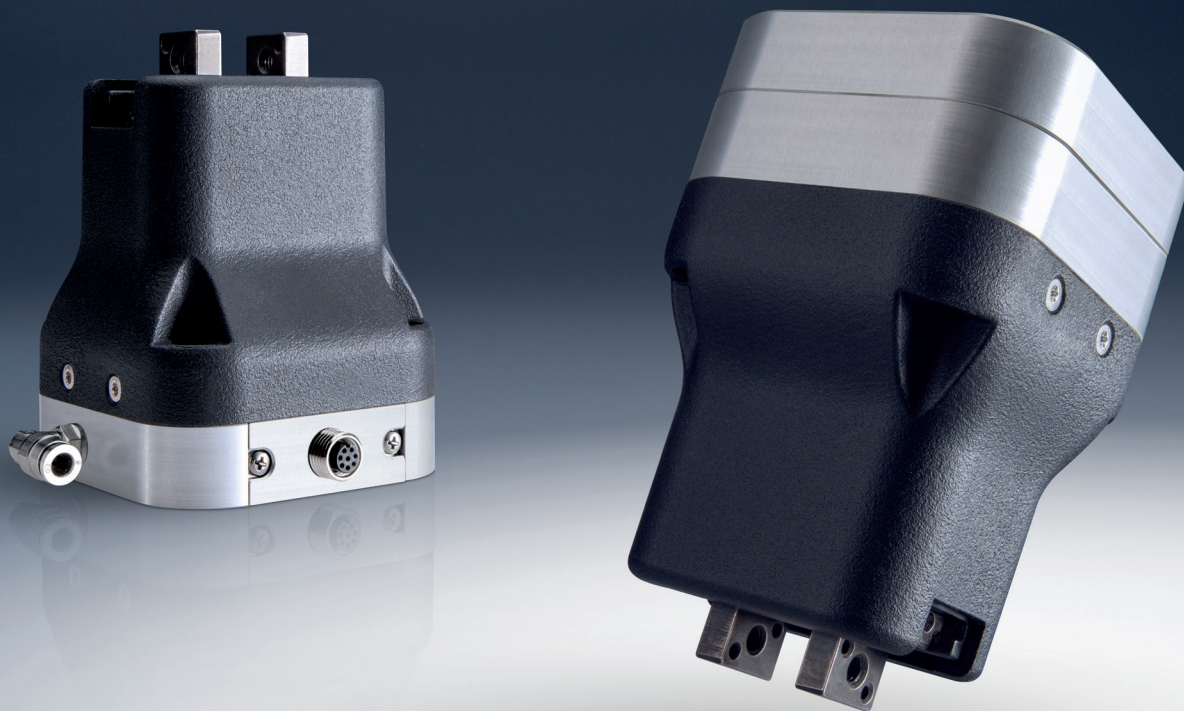

Contents

Chapter 1 Introduction	1
1.1 About this manual	1
1.2 Unit overview	1
Chapter 2 General recommendations	2
2.1 Use	3
2.2 Limitations of use	4
2.3 Maintenance	4
2.4 Gripper accessory	4
Chapter 3 Product specifications	5
3.1 Coding example	5
3.2 Specifications	7
3.3 Gripping force	9
3.3.1 Force vs distance	9
3.3.2 Distance vs eccentricity	10
3.4 Dimensions	12
3.4.1 Gripper	12
3.4.2 Robot-gripper mechanical interface	13
3.4.3 Fingers	13
3.5 Centre of gravity	14
3.6 Tool centre point	15
3.7 Electrical interface	16
3.7.1 Gripper connection	16
3.7.2 Robot cable	17
Chapter 4 Operating method	18
4.1 Installation	18
4.1.1 Gripper mounting	19
4.1.2 Finger mounting	20
4.1.3 Cable connection	21

Introduction

1.1 About this manual

This manual contains the technical description of pneumatic collaborative gripper CSSP, designed by Camozzi Automation S.p.A.

▲ Failure to observe the information contained in this manual can result in injury or equipment damage.

Please contact Camozzi Automation S.p.A. for technical assistance.

PRODUCT SPECIFICATIONS AND DATA ARE SUBJECT TO CHANGE WITHOUT NOTICE.

© Camozzi Automation S.p.A. All rights reserved.

1.2 Unit overview

The pneumatic collaborative gripper CSSP is composed of a standard gripper and two integrated valves. It's available in two versions which are different for the gripping force maintaining. The design and the performance of the gripper make the system suitable for collaborative application. Integrated sensors allow to recognize the presence or absence of the gripped piece. In the following chapters are described the technical data of the system and the terms of use.

General recommendations

- The components must be fixed correctly, using, where available, the special brackets and checking that the fixing remains effective even when the actuator operates at high cyclic stress or under strong vibrations.
- Where there are strong vibrations, special devices/systems must be used to reduce the effect on the component.
- Install dryers in order to avoid the formation of rust in the internal components.
- Make sure that the air ducts are properly connected to their respective connectors once the component is installed.
- Always ensure that the surrounding equipment and persons are not at risk of harm from unexpected movements of the actuators.

The products comply with the following technical standards:

- **ISO 12100:2010 - Safety of machinery**
- **ISO 10218:2011 - Robots and robotic devices**
- **ISO/TS 15066:2016 - Collaborative industrial robotic package**
- **ISO 4414:2010 - Pneumatic fluid power**

Please comply with the recommendations for safe use described in this document. These recommendations are classified so as to identify the level of danger and the possible associated risk.

DANGER

In extreme conditions, errors or carelessness could lead to serious injury or death.

- Some hazards can be associated with the product only after it has been installed on the machine/equipment. It is the responsibility of the end user to identify these hazards and reduce the risks associated with them.
- The products covered by this manual can be used in circuits that must comply with ISO 13849-1.
- For information regarding the reliability of the components, contact Camozzi Automation.
- Read the information in this document carefully before using the product.
- Keep this document in a safe place and close at hand for the whole of the product life cycle.
- Pass this document on to any subsequent holder or user.
- The instructions in this manual must be followed in combination with the instructions and further information regarding the product described in this manual, which can be found using the following references:
 - Website www.catalogue.camozzi.com
 - Camozzi Automation Handling and Vacuum Catalogue
 - Customer Service
- Assembly and commissioning must be performed by qualified and authorised personnel only, according to these instructions.

Chapter 2 General recommendations

- It is the responsibility of the system/machine designer to choose correctly the most appropriate pneumatic component according to the required use.
- It is the responsibility of the system/machine designer to ensure the correct electrical connection through adequate systems and protections.
- The use of appropriate personal protection is recommended to minimise the risk of injury.
- For all those situations of use not covered in this manual and in situations in which damage could be caused to property, persons or animals, contact Camozzi Automation before use.
- Do not make unauthorised modifications to the product. In the event of any such modifications, the user shall be liable for any possible damage caused to property, persons or animals.
- It is recommended to comply with all safety regulations that apply to the product.
- Do not perform any maintenance on the machine/system until you have verified the safety of work conditions.
- Before installation or maintenance, make sure that the specifically designed safety locks have been activated, then shut down the electricity power supply (where necessary) and the system pressure supply, draining all the residual compressed air from the system and deactivating the residual energy stored in springs, condensers, containers and gravity.
- After installation or maintenance, reconnect the system's pressure and electricity supply (where necessary) and check the proper operation and tightening of the product. In case of leaks or malfunctioning, the product must not be put into operation.
- Do not wash the product with aggressive substances or varnish it before consulting Camozzi Automation.

2.1 Use

- Make sure that the pressure of the compressed air distribution network and all operating conditions are within the permissible values.
- The product can be put into operation only in compliance with the specifications shown; where these specifications are not followed, the product can be put into operation only after authorisation by Camozzi Automation. Observe the maximum static loads indicated on the catalog.
- Follow the indications shown on the identification label.
- The product must only be supplied with compressed air at least of 7.4.4 quality according to ISO 8573-1 provisions.
- Pneumatic grippers are mainly used for gripping and handling objects.

2.2 Limitations of use

WARNING

- Do not exceed the technical specifications shown under “General characteristics” and in the general Camozzi Automation catalogue. Where these specifications are not followed, the product can be put into operation only after authorisation by Camozzi Automation.
- Do not install the product in environments where the air itself may cause hazards.
- With the exception of specific intended uses, do not use the product in environments where direct contact with corrosive gases, chemicals, salt water, water or steam may occur.
- Do not scratch the surface of the product or force any mechanism, do not alter the tightening elements on the product.

2.3 Maintenance

WARNING

Before performing any maintenance operation, the product must be isolated from any energy source. Check the conditions to prevent the sudden release of parts, then switch off the air supply and allow the discharge of residual pressures before proceeding.

- Incorrectly performed maintenance operations can compromise the good working order of the product and harm surrounding persons.
- Make sure the condensate is removed continuously from the filters found on the line.
- Never disassemble a pressurised unit.
- Always remove accessories before maintenance.
- Always make sure that you are wearing the correct safety equipment required by local authorities and by applicable legislation.
- In the event of maintenance, do not disassemble without the authorisation of qualified Camozzi Automation personnel. Unauthorised repair attempts compromise the guarantee of conformity of the product to the specifications, with the total invalidation of the relative right to repair under warranty or replacement of the product or part thereof.

2.4 Gripper accessory

- To design the gripper accessory, see the product dimensions and respect the working range of the product.
- It is possible to attach accessory to the grippers that improve the grip.
- The dimensions, weight and the grip point of the accessories must not compromise the operation and duration of the gripper.

Product specifications

3.1 Coding example

Gripper

CSSP	-	40	-	NC
------	---	----	---	----

CSSP: series

40: size

NC: functioning

Functioning	Description
NC	Closing gripping force maintaining
NO	Opening gripping force maintaining

The screws and the positioning pins for mounting the gripper on the robot flange are included.

Gripper accessory

Robot-gripper mechanical interface

P	-	CSSP
---	---	------

P: mechanical interface between robot and gripper, in accordance with **ISO 9409-1-50-4-M6**. Include the positioning pin and the screws to mount the flange on the robot wrist. The following robots are compatible:

Robot manufacturer	Robot
UNIVERSAL ROBOT	UR3e UR5e UR10e UR16e
ABB	GoFa
FANUC	CRX 5ia CRX 10ia CRX 10ia/L CRX 20ia/L CRX 25ia
DOOSAN	M0609 M0617 M1013 M1509 H2017 H2515
OMRON	TM5 TM5S TM7S TM12 TM12S TM14 TM14S TM16 TM20

Robot-gripper electrical interface

Mod.	Robot manufacturer	Robot
CS-DL08MC-E020U	UNIVERSAL ROBOT FANUC	UR3e UR5e UR10e UR16e CRX 5ia CRX 10ia CRX 10ia/L CRX 20ia/L CRX 25ia
CS-DY08MC-E020A	ABB	GoFa
CS-DN08MC-E020D	DOOSAN	M0609 M0617 M1013 M1509 H2017 H2515
CS-DN08MC-E0330	OMRON	TM5 TM5S TM7S TM12 TM12S TM14 TM14S TM16 TM20

Fingers

F	-	CSSP	-	40
----------	---	-------------	---	-----------

F: include two standard fingers, with caps fitted on them, and the screws to mount them on the jaws.

3.2 Specifications

Function	Description
Type of construction	Self-centering parallel collaborative gripper with T-guide
Operation	Single acting (NO, NC)
Bores	40 mm
Air connections	M5 (tube \varnothing 6mm)
Working temperature	5°C ÷ 50°C
Storage temperature	-10°C ÷ 60°C
Maximum use frequency	3Hz (NC) 1.7Hz (NO)
Repeatability	0.02 mm
Fluids	Filtered air in class 7.4.4 according to ISO 8573-1. In case lubricated air is used, we recommend ISOVG32 oil and to never interrupt lubrication.
Protection class	IP 40
Compatibility	ROHS and REACH Directives
Certifications	ISO 12100, ISO 10218, ISO TS 15066, ISO 4414
Working pressure	4 ÷ 7 bar
Voltage	24V
Max current absorbed	0.25A
Closing force per jaw at 0 mm (6 bar)	94N (NC) 62N (NO)
Opening force per jaw at 0 mm (6 bar)	76N (NC) 107N (NO)
Stroke per jaw	6 mm

Table 3.1: Technical data

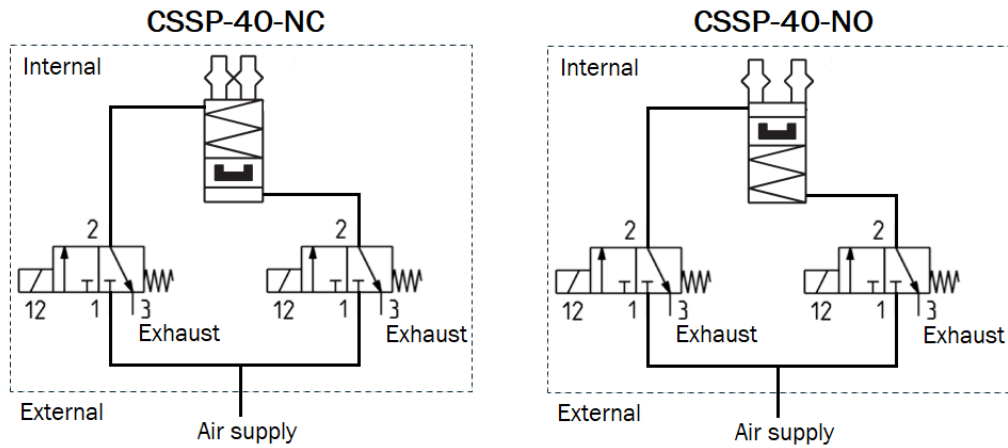

Figure 3.1: Pneumatic scheme

Notes on functioning

- When power is lost, the valves discharge air from the relative gripper chambers and fingers close in the NC version, while they open in the NO version. The force is given only by the spring. If the last signal is saved, the gripper returns to the previous condition when the power supply is restored.
- In the event of pneumatic failure, the valves maintain their position and the chambers lose pressure, while the fingers have the same behaviour described previously for the power loss. The force is given only by the spring. If the valves don't change their position, the fingers return to the previous condition when the air supply is restored.

3.3 Gripping force

3.3.1 Force vs distance

In the following graphs, external and internal gripping forces are represented as a function of the operating pressure and distance of the gripping point.

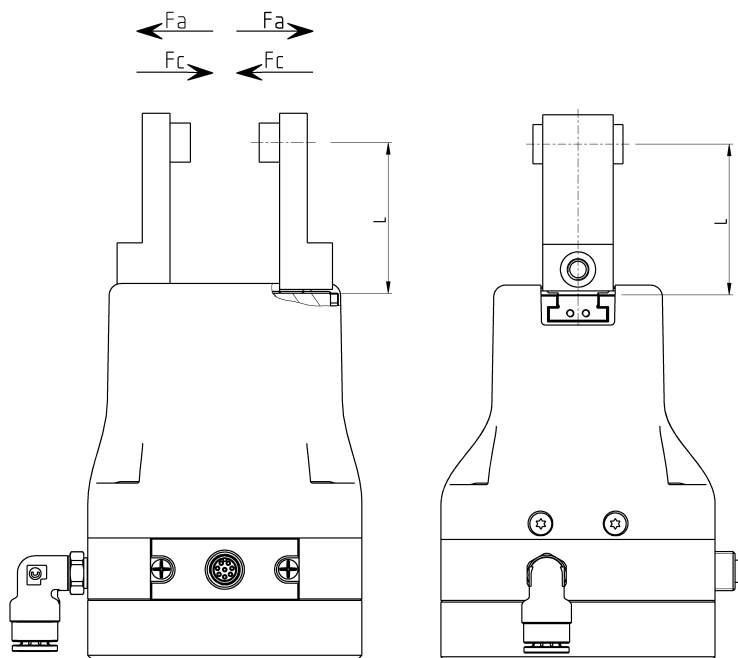

F_C = _____
 F_a = _____
 F_{CM}/F_{AM} = _____

L = distance of the gripping point
 F_a = opening force
 F_c = closing force
 F_{AM} = opening spring force
 F_{CM} = closing spring force

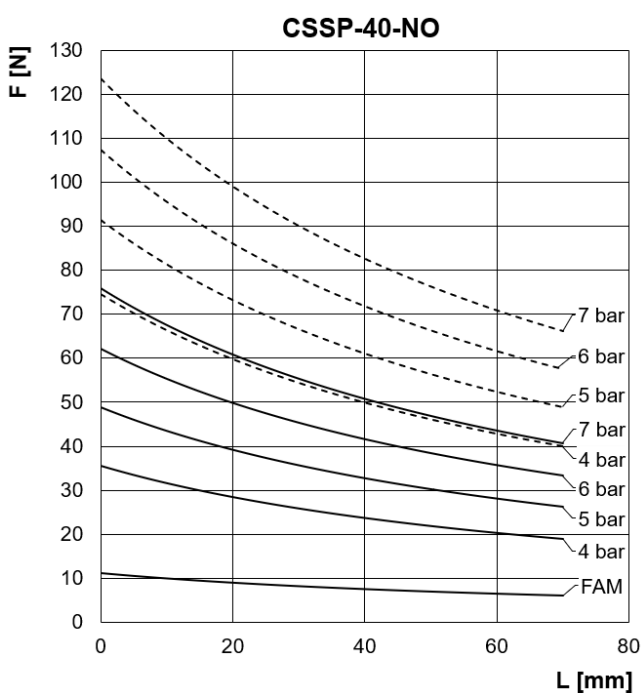
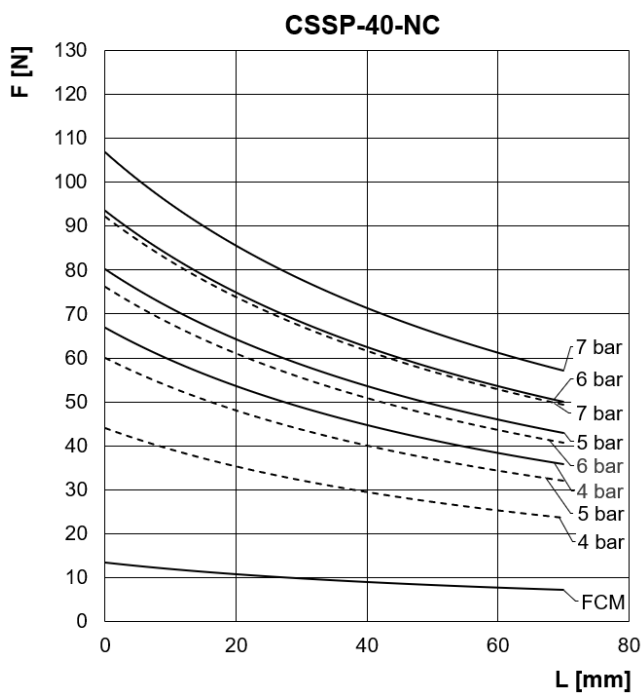

3.3.2 Distance vs eccentricity

In the following graphs, is represented the working range as a function of distance and eccentricity of the gripping point.

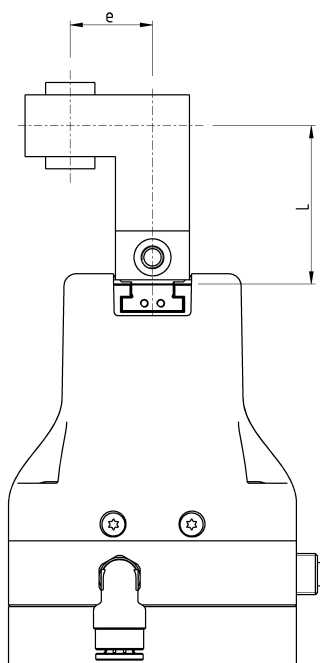

L = distance of the gripping point
e = eccentricity of the gripping point

• CSSP-40-NC

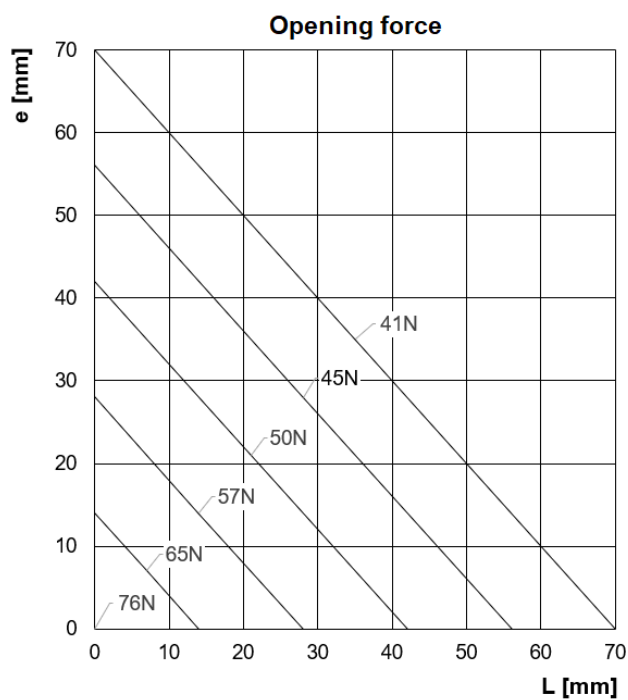
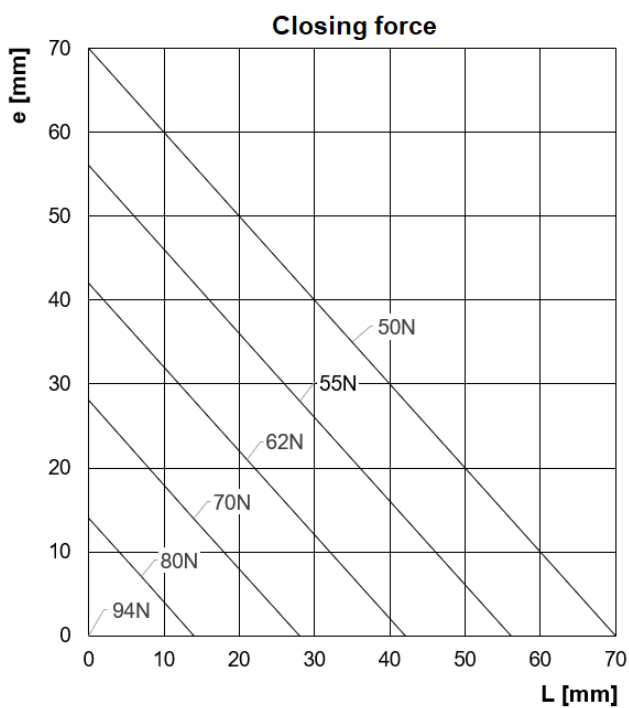

• **CSSP-40-NO**

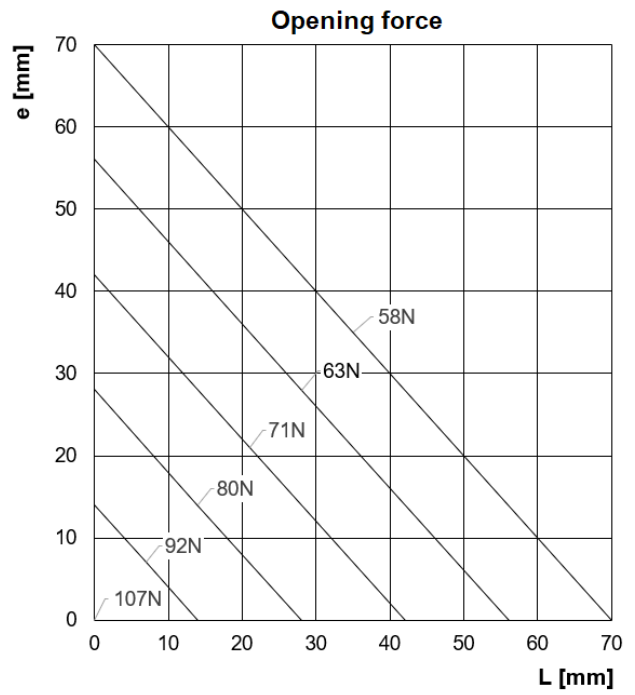
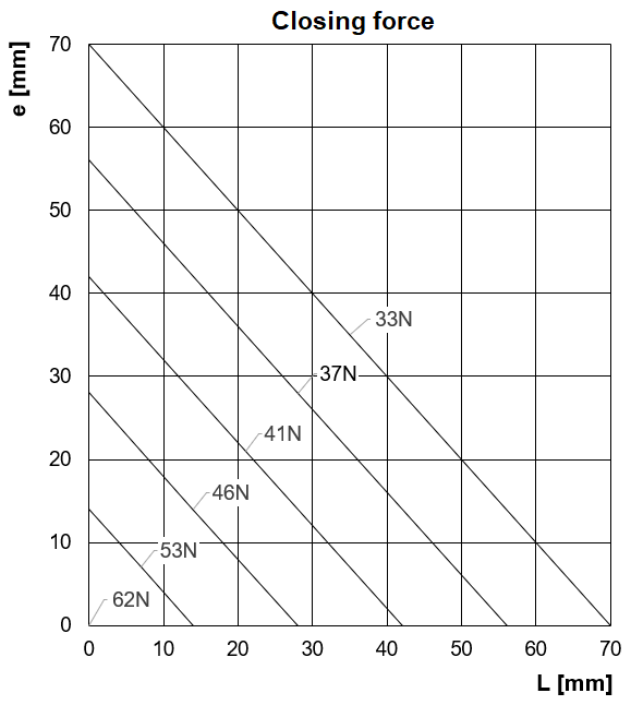

3.4 Dimensions

3.4.1 Gripper

Below are represented the dimensions of the gripper.

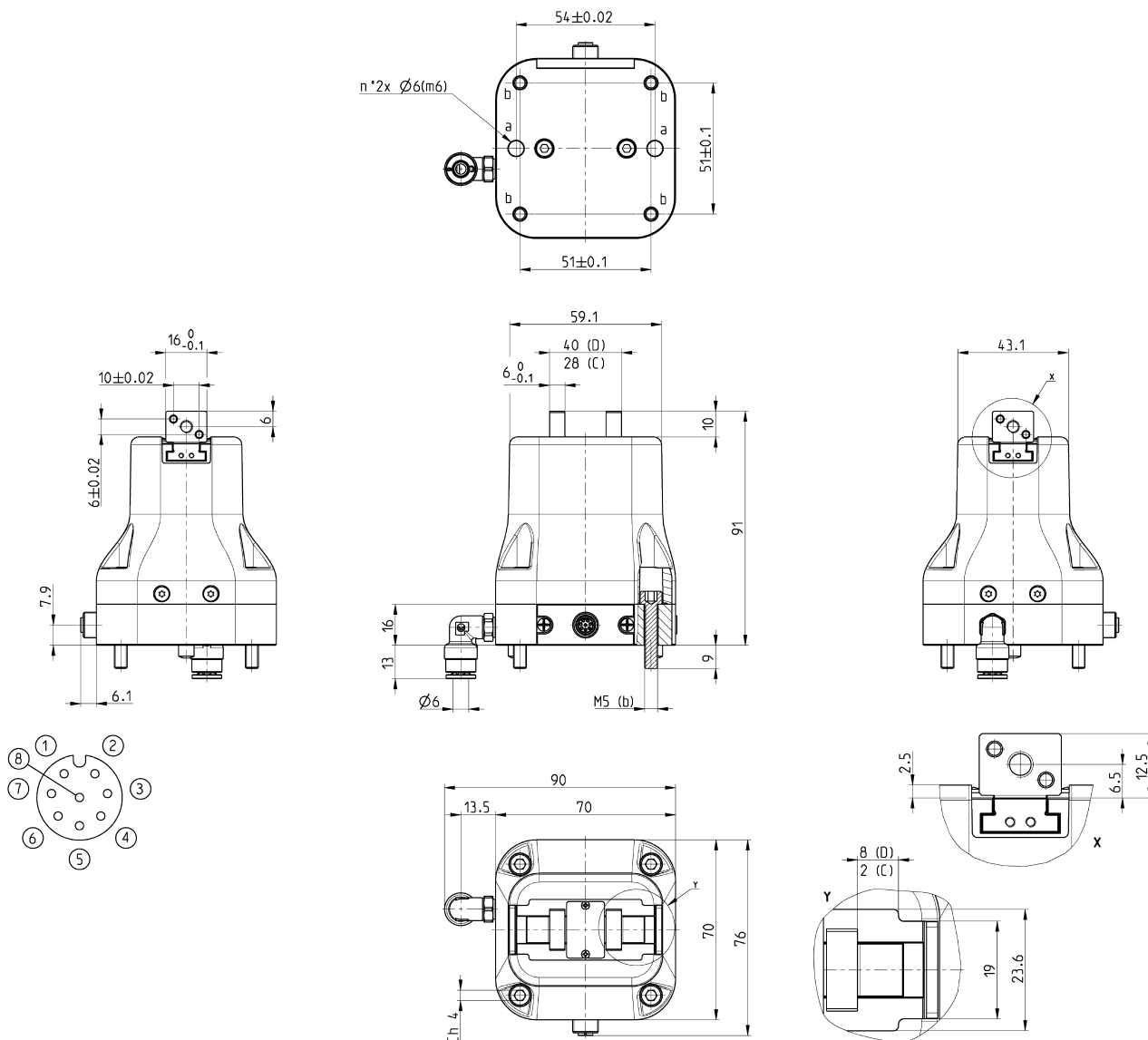

	CSSP-40-NC	CSSP-40-NO
Weight (g)	460	440

Chapter 3 Product specifications

3.4.2 Robot-gripper mechanical interface

Below are represented the dimensions of the mechanical interface.

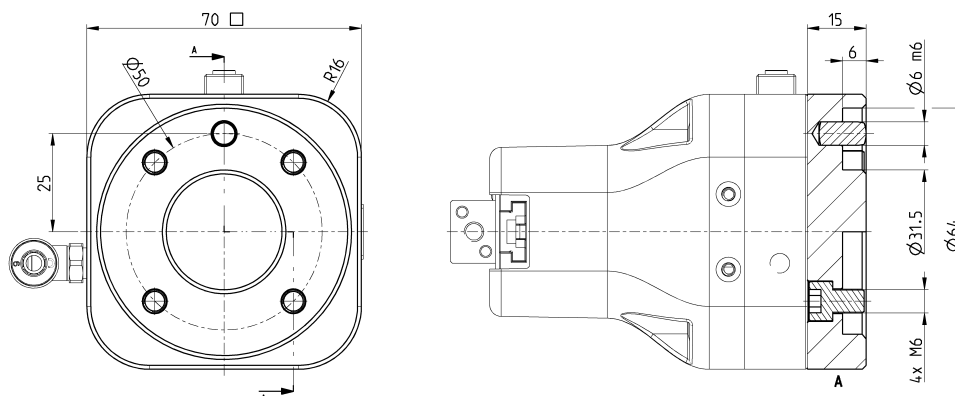

	P-CSSP
Weight (g)	140

3.4.3 Fingers

Below are represented the dimensions of the fingers.

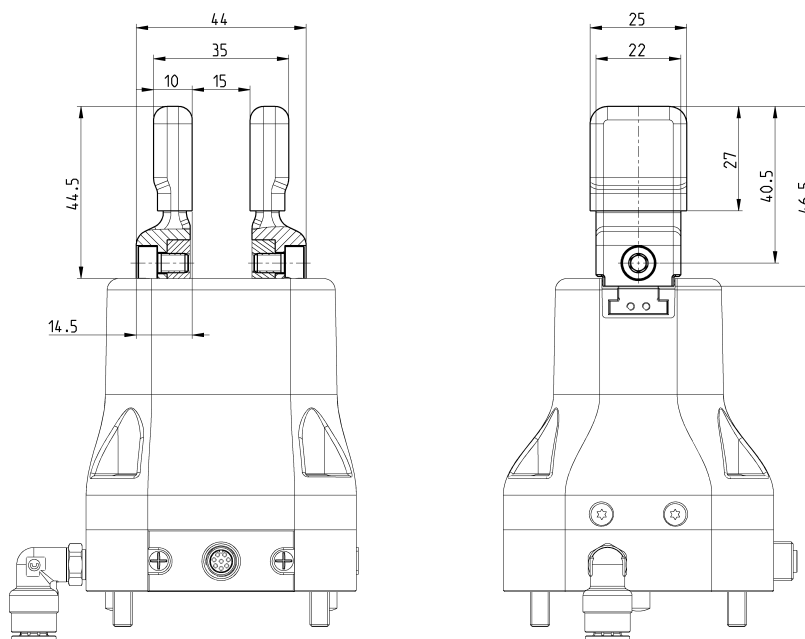

	F-CSSP-40
Weight (g)	25*

*: is the weight of a single finger

3.5 Centre of gravity

The centre of gravity  is calculated with the robot flange and standard fingers; the support surface between the robot interface flange and the robot wrist is used as a plane of the reference system.

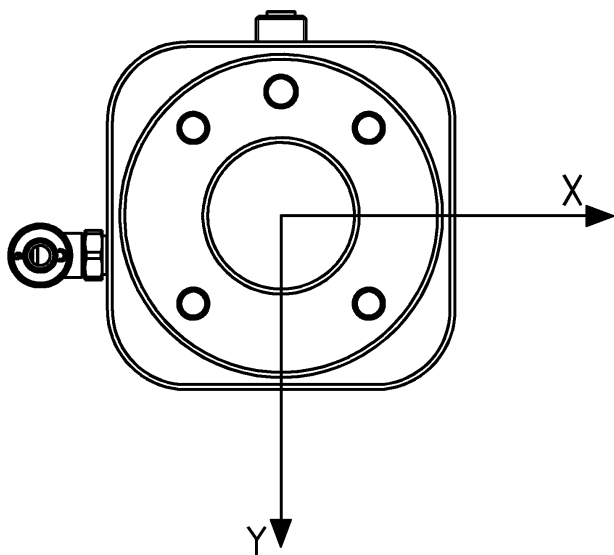

Centre of gravity			
	X[mm]	Y[mm]	Z[mm]
CSSP-40-NC	-3.09	0.14	36.32
CSSP-40-NO	-3.17	0.14	36.64

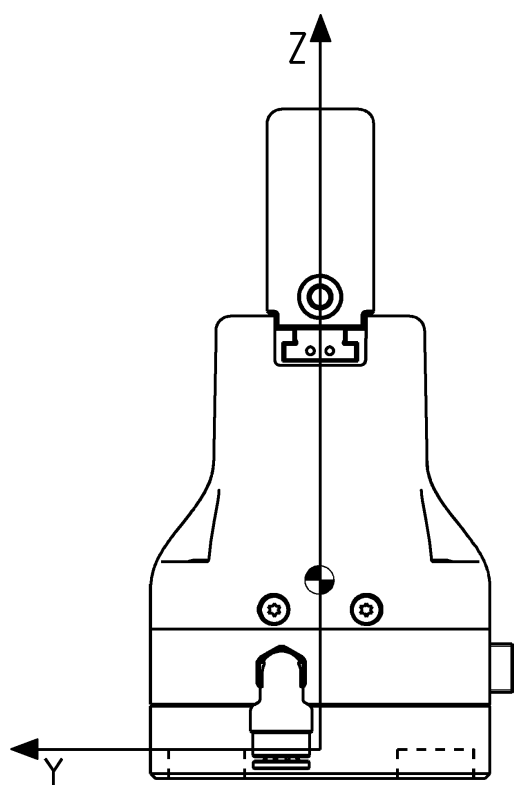
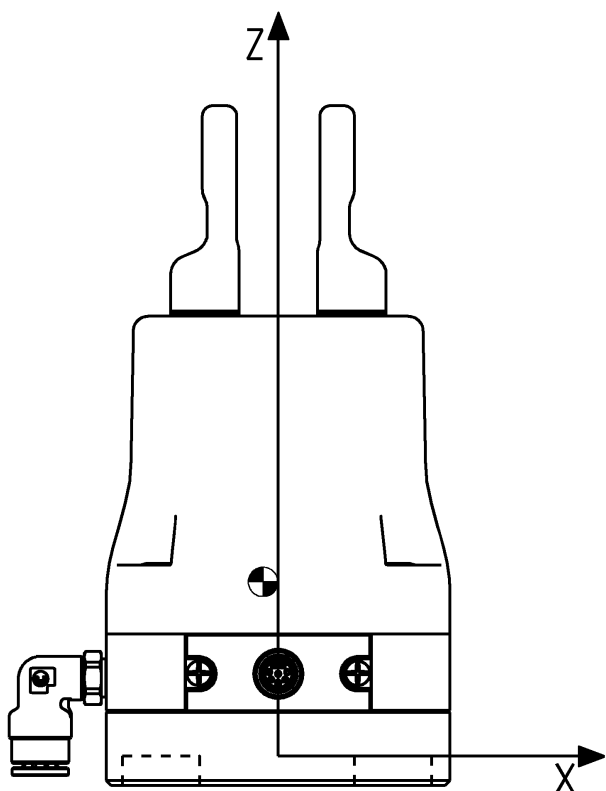

3.6 Tool centre point

The tool centre point ● is calculated with the robot flange and standard fingers; the support surface between the robot interface flange and the robot wrist is used as a plane of the reference system.

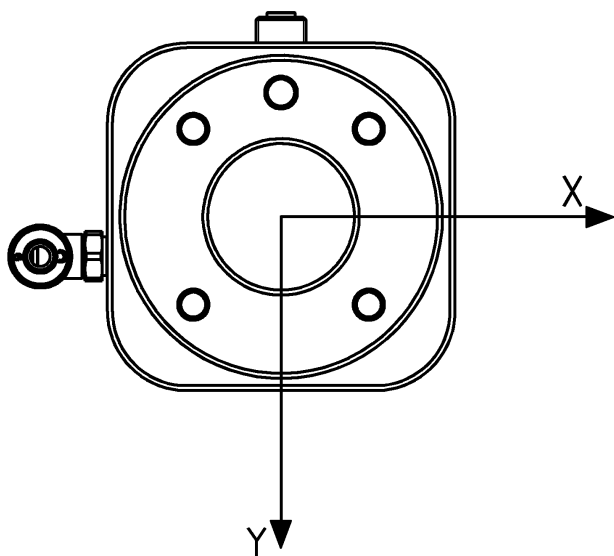

Tool centre point *		
X[mm]	Y[mm]	Z[mm]
0	0	123.5

*= is the same for NC and NO version

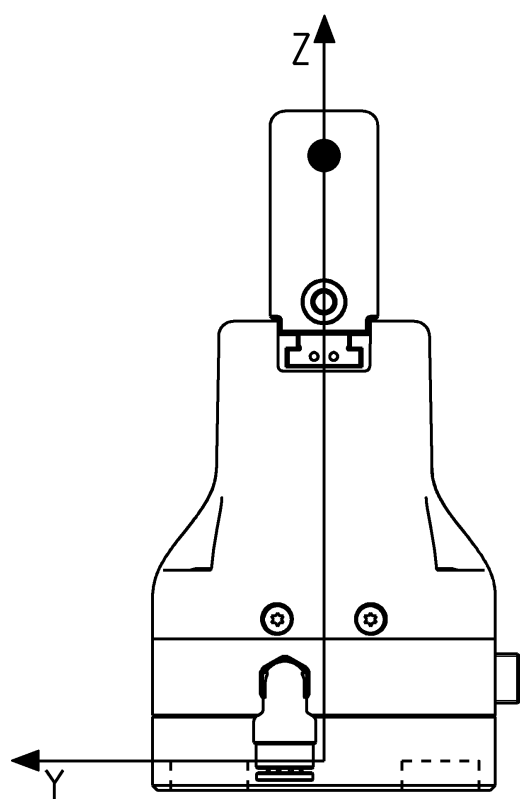
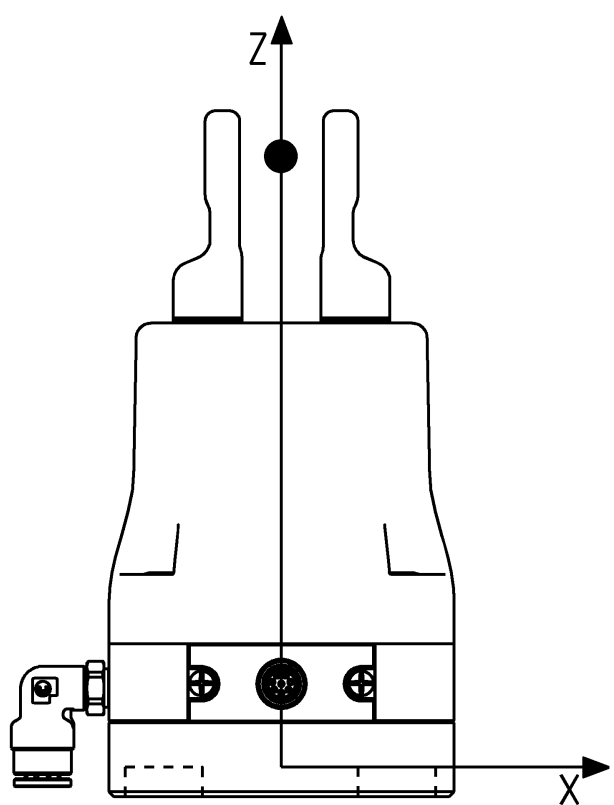

3.7 Electrical interface

3.7.1 Gripper connection

The gripper is provided of a 8-pin M8 female connector, represented in figure 3.2. The **Phoenix SAC-8P-M 8MS** is a suitable industrial cable; the eight wires inside the cable have different colors representing different functions, listed in the table 3.2.

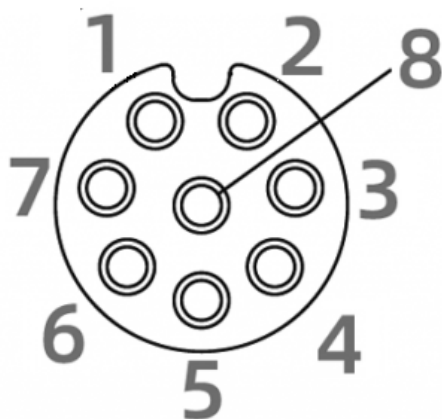

Figure 3.2: Gripper M8 8-pin female connector

Pin number	Function	Cable colour
1	Not connected	White
2	Not connected	Brown
3	Close end stroke sensor (DO PNP +24V)	Green
4	Open end stroke sensor (DO PNP +24V)	Yellow
5	Power supply +24 V DC \pm 10 %	Gray
6	Closing command (DI 0 V +24V)	Pink
7	Opening command (DI 0 V +24V)	Blue
8	Power supply reference 0 V DC	Red

Table 3.2: Cable connection assignment

3.7.2 Robot cable

To be plug and play, it is possible to choose a cable depending on the robot type. In the following table are listed the informations about them.

Robot manufacturer	Robot	Gripper side	Robot side	Length [mm]
UNIVERSAL ROBOT	UR3e UR5e UR10e UR16e	M8 8pin male	M8 8pin female	230
FANUC	CRX 5ia CRX 10ia CRX 10ia/L CRX 20ia/L CRX 25ia	M8 8pin male	M8 8pin female	230
ABB	GoFa	M8 8pin male	M8 3pin male M8 4pin male	275 245
DOOSAN	M0609 M0617 M1013 M1509 H2017 H2515	M8 8pin male	M8 8pin male	230
OMRON	M5 TM5S TM7S TM12 TM12S TM14 TM14S TM16 TM20	M8 8pin male	M8 8pin male	330

Table 3.3: Robot cable information

Operating method

WARNING

- When unpacking, take great care not to damage the product.
- Check for any defects caused by transport or storage of the product.
- Remove all the securing/locking devices of the moving parts.
- Separate the packaging materials for recycling or disposal according to the regulations in force in your country.
- Before operating the component, check that the characteristics and performance stated in the catalogue correspond to those required.
- Use appropriate overpressure protection devices when installing the component.
- Prevent, as far as possible, any sudden changes in pressure in the circuit on which the component is installed.
- When installing the component, make sure that there is no danger due to mechanical movements.

4.1 Installation

WARNING

- Before installation shut down the electricity power supply (where necessary) and the system pressure supply, draining all the residual compressed air from the system and deactivating the residual energy stored in springs, condensers, containers and gravity.
- After installation reconnect the system's pressure and electricity supply (where necessary) and check the proper operation of the product. In case of leaks or malfunctioning, the product must not be put into operation.
- Do not install the product in environments where the air itself may cause hazards.
- Do not install the product in the presence or proximity of strong electromagnetic fields or large masses of ferromagnetic material.
- Install the component in an area where set-up and maintenance can be easily performed and do not lead to hazards for the operator.
- Tighten the screw within the specified torque range when mounting the gripper and the attachments.

Chapter 4 Operating method

4.1.1 Gripper mounting

1. Connect the fitting ① (included) on the gripper ②.

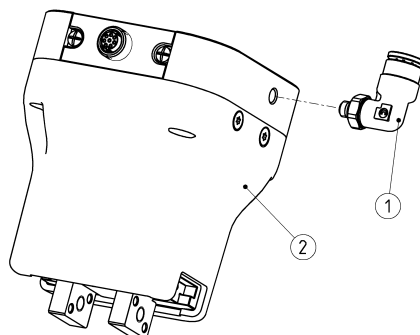

2. After inserting the pin ③ (included) in the robot wrist hole ④, mount the robot flange ⑤ with the four hexagon socket head cap screw ⑥ (included).

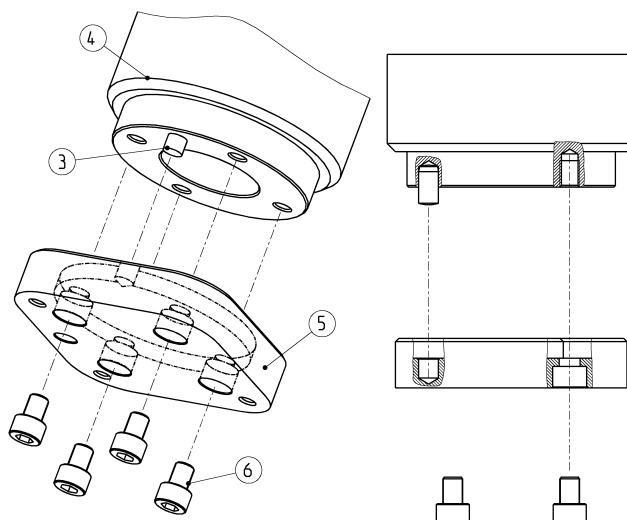

- ⑥ M6x8 UNI5931: maximum tightening torque 9.5 Nm.

Chapter 4 Operating method

3. Insert the pins ⑦ (included) in the gripper ②; center the gripper and fasten it on the robot flange ⑤ with the four hexagon socket head cap screw ⑧ (included).

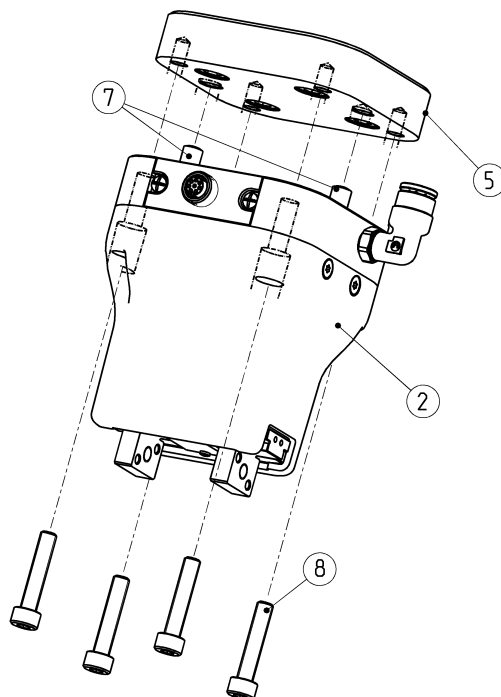

⑧ M5x25 UNI5931: maximum tightening torque 5.5 Nm.

4.1.2 Finger mounting

1. Connect the standard fingers ① (included) on the gripper jaws ② with the hexagon socket head cap screw ③ (included).

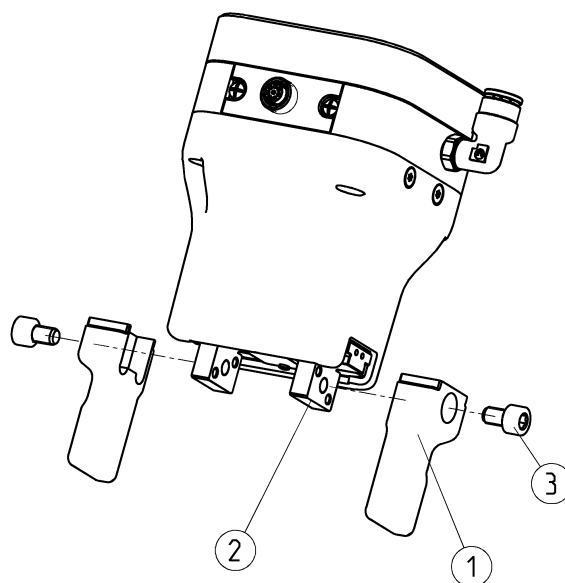

③ M5x8 UNI5931: maximum tightening torque 5.5 Nm.

Chapter 4 Operating method

4.1.3 Cable connection

In cases where the cable construction does not identify the uniqueness of the connection, see the labels on the cable to connect the correct sides to the respective device.

1. Connect the T side of the cable ① to the gripper connector ②.

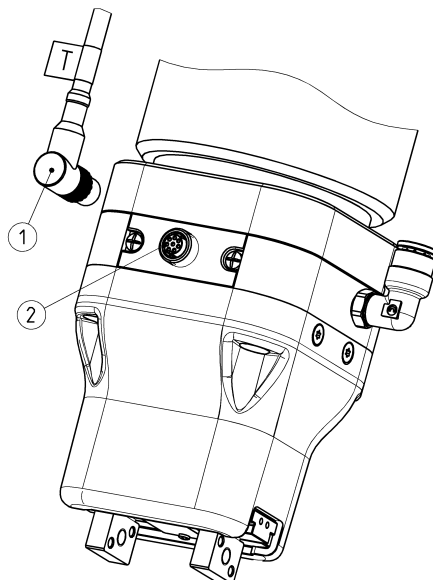

2. Connect the R side of the cable ③ to the robot connector ④.

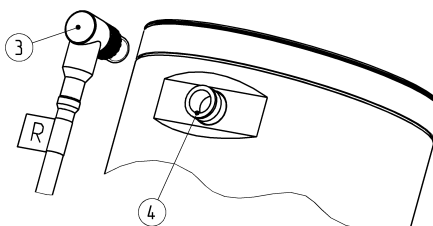

Contacts

Camozzi Automation S.p.A.

REGISTERED OFFICE:

Via R. Rubattino, 81 - 20134 Milano (Italy)
P.IVA IT 03207930177

OPERATIONAL HEADQUARTERS:

Via Eritrea, 20/I - 25126 Brescia (Italy)
Tel. +39 03037921 | Info@camozzi.com
www.camozzi.com

Technical assistance

Tel. +39 030 3792790
service@camozzi.com

Product certification

Information concerning product certifications,
EC standards, conformity declarations and instructions
productcertification@camozzi.com



Automation

